

DE MONTAGEANWEISUNG
EN ASSEMBLY MANUAL
PL INSTRUKCJA MONTAŻU

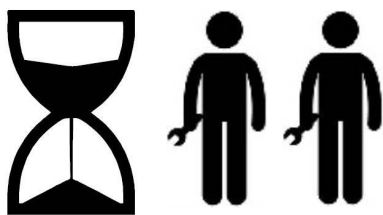

~70 min

DE Für die Montage benötigen Sie folgende (nicht vom Hersteller bereitgestellt) :

EN Tools necessary for assembly (not supplied by the manufacturer) :

PL Narzędzia potrzebne do montażu (nie są dostarczane przez producenta) :

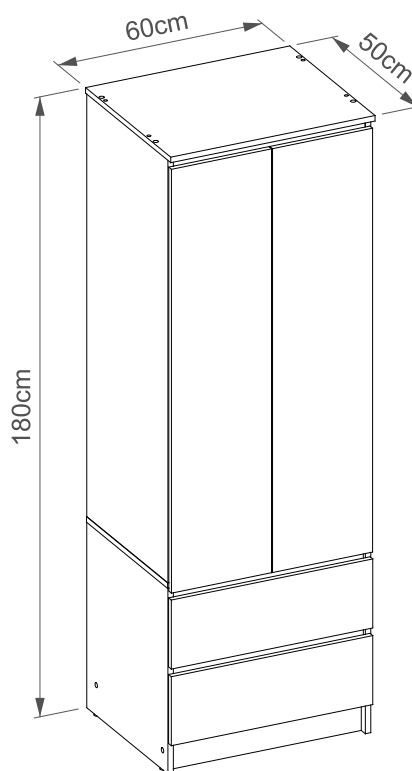
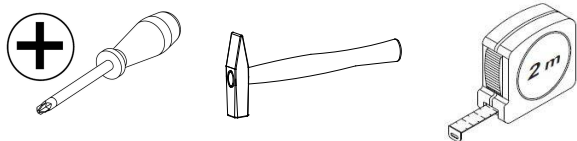

DE **WICHTIGE INFORMATIONEN!**

Lesen Sie die Sicherheitshinweise Sorgfältig durch, bevor Sie das Produkt verwenden.
Bitte Lesen Sie die Bedienungsanleitung und speichern Sie es für die zukünftige Verwendung.

EN **IMPORTANT INFORMATION!**

Please read the entire manual carefully before starting to assemble and/or using this product.
Follow the manual thoroughly and keep it for further reference.

PL **WAŻNE INFORMACJE!**

Przed użyciem produktu należy dokładnie zapoznać się ze wskazówkami bezpieczeństwa.
Należy zapoznać się z instrukcją obsługi i zachować ją do użytku w przyszłości.

DE ACHTUNG!

Wir installieren keine beschädigten Elemente! Im Falle einer Beschwerde teilen Sie uns dies bitte unter mit das Thema des Problems an die E-Mail
Unser Mitarbeiter wird sich mit Ihnen in Verbindung setzen, um das Problem so schnell wie möglich zu lösen. wenn es möglich ist. Bitte markieren Sie die beschädigten oder fehlenden Elemente in der Anleitung und senden Sie zusammen mit der Anwendung.

EN ATTENTION!

Do not install damaged components! In the event of a complaint, please let us know at the subject of the problem to the e-mail
Our employee will contact you to solve the problem as soon as possible. Please mark the damaged or missing elements on the assembly manual and send them together with the application.

PL UWAGA!

Uszkodzonych elementów nie montujemy! W razie reklamacji prosimy o informację na temat zaistniałego problemu na e-maila
Nasz pracownik skontaktuje się z Państwem aby jak najszybciej rozwiązać problem. Jeśli to możliwe prosimy zaznaczyć na instrukcji uszkodzone lub brakujące elementy i wysłać łącznie z zgłoszeniem.

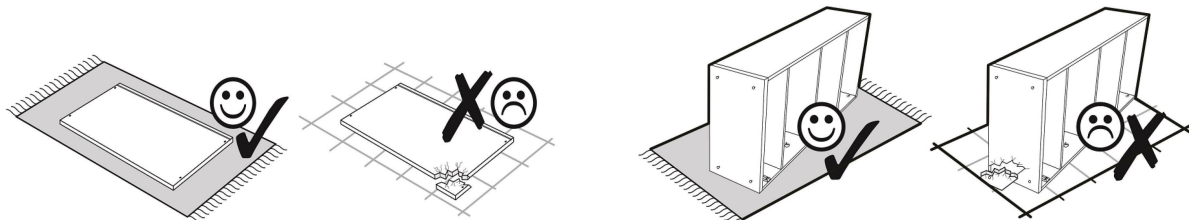

DE WARNUNG, UM KRATZER ZU VERMEIDEN!

Um Kratzer zu vermeiden, sollte dieses Möbelstück auf einer weichen Basis wie einem Teppich montiert, gefaltet werden.

EN WARNING TO AVOID SCRATCHES!

In order to avoid scratching this furniture should be assembled on a soft layer - could be a rug.

PL OSTRZEŻENIE WS. USZKODZEŃ!

Aby uniknąć rys, ten mebel powinien być montowany, składany na miękkim podłożu, np. dywanie

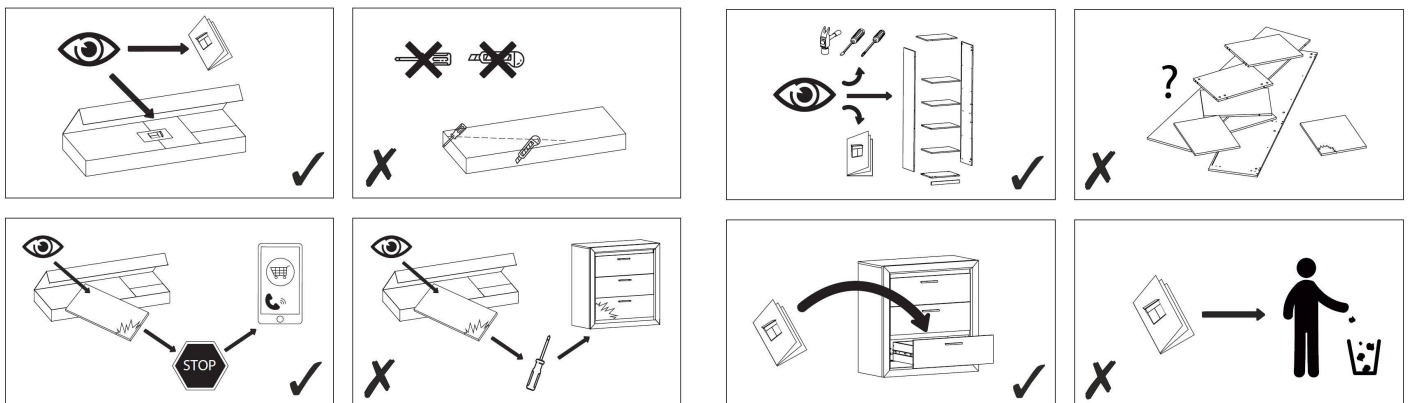

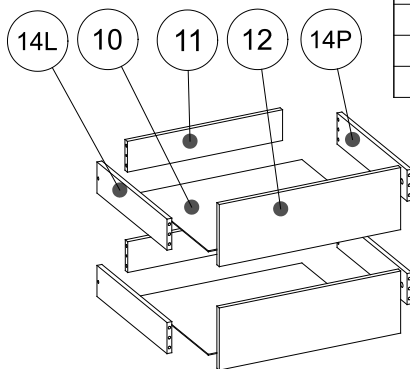
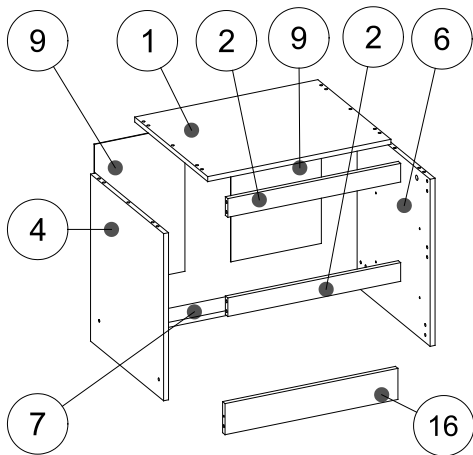
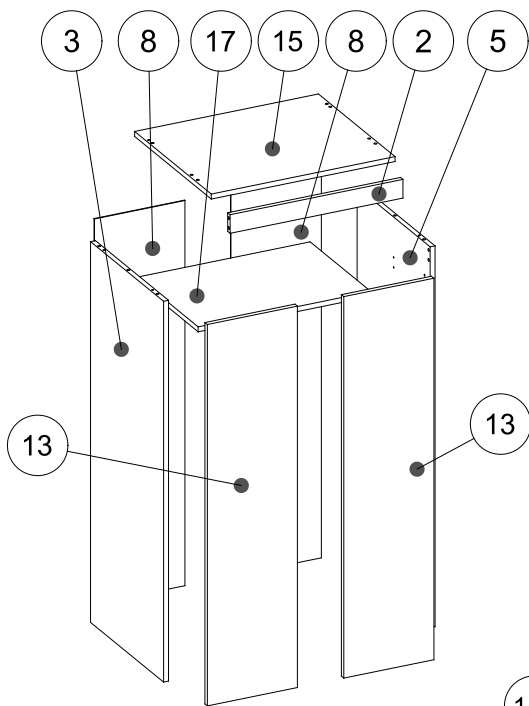

PACZKA I

TEIL/PART/LP	GRÖSSE/SIZE/WYMIAR	ANZ./QTY./IL.
1	602x480x16mm	1
2	568x60x16mm	3
3	1226x480x16mm	1
4	538x480x16mm	1
5	1226x480x16mm	1
6	538x480x16mm	1
7	568x90x16mm	1
8	1240x297x3mm	2
9	468x297x3mm	2
10	465x540x3mm	2

PACZKA II

TEIL/PART/LP	GRÖSSE/SIZE/WYMIAR	ANZ./QTY./IL.
11	510x99x16mm	2
12	596x200x16mm	2
13	1228x296x16mm	2
14L	460x100x16mm	2
14P	460x100x16mm	2
15	604x504x16mm	1
16	568x100x16mm	1
17	568x400x16mm	1

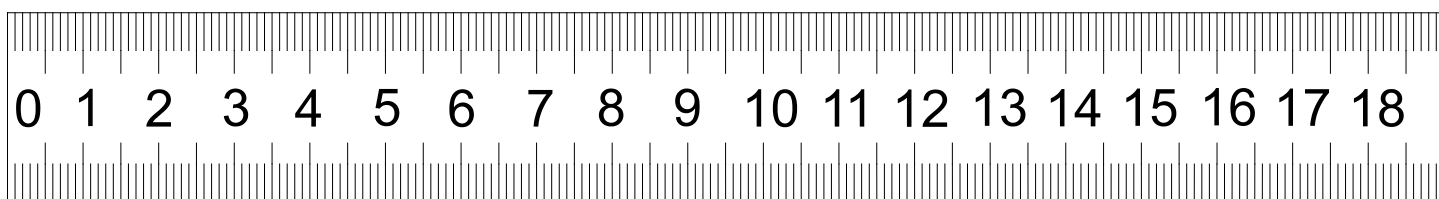
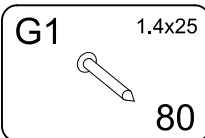
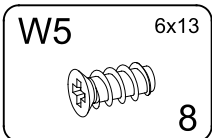
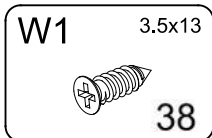
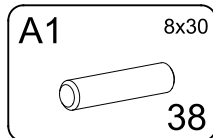
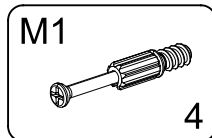
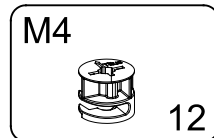
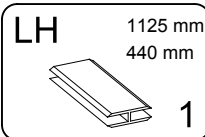
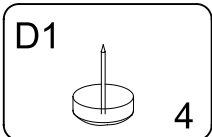
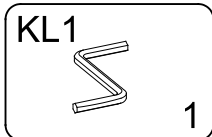
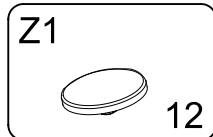
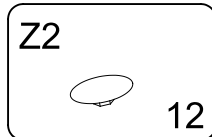
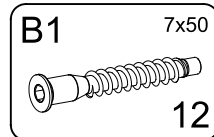
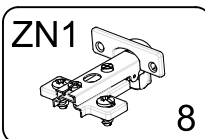
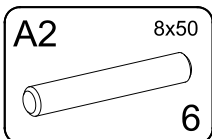
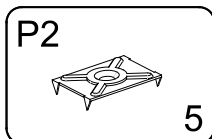
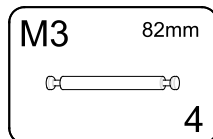
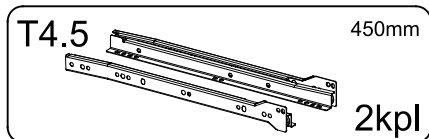
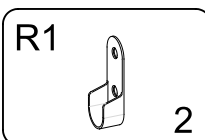
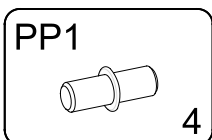
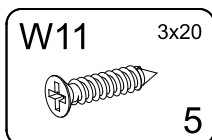
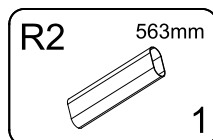
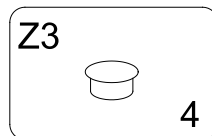

► **1** DE Sie benötigen für die Montage:
 EN You need for fitting-up:
 PL Niezbędne do montażu:

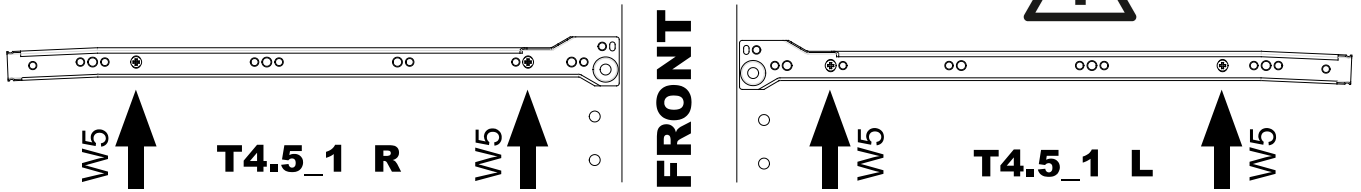
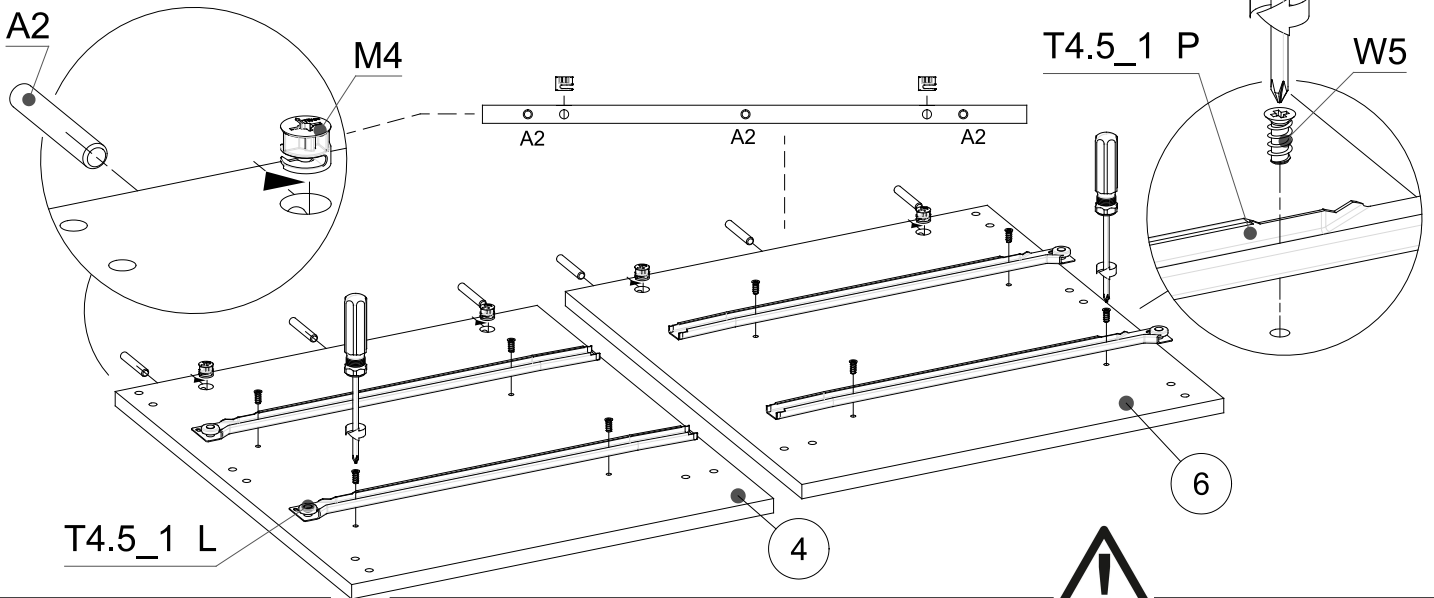
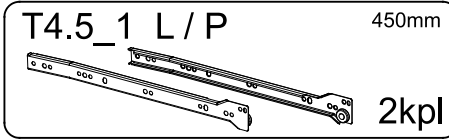
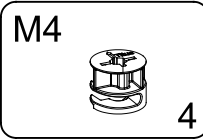
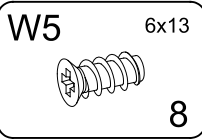
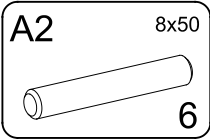
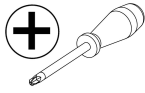

► **2** DE Sie benötigen für die Montage:
 EN You need for fitting-up:
 PL Niezbędne do montażu:

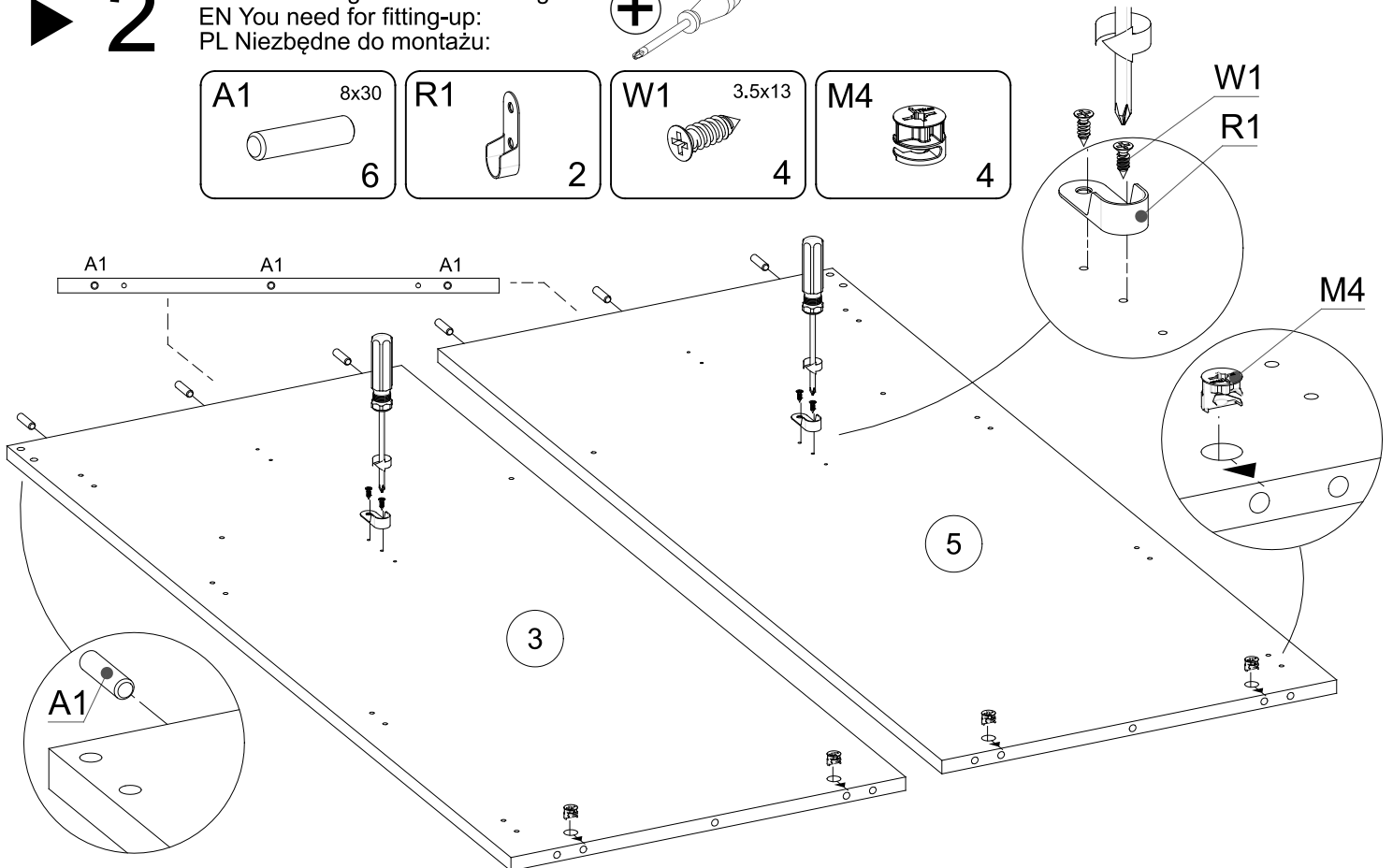
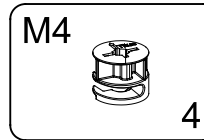
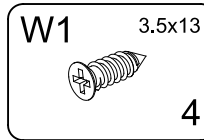
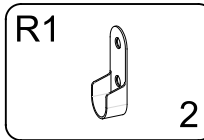
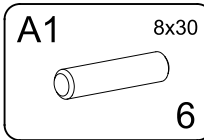
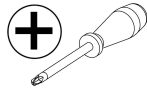

▶ 3

DE Sie benötigen für die Montage:
 EN You need for fitting-up:
 PL Niezbędne do montażu:

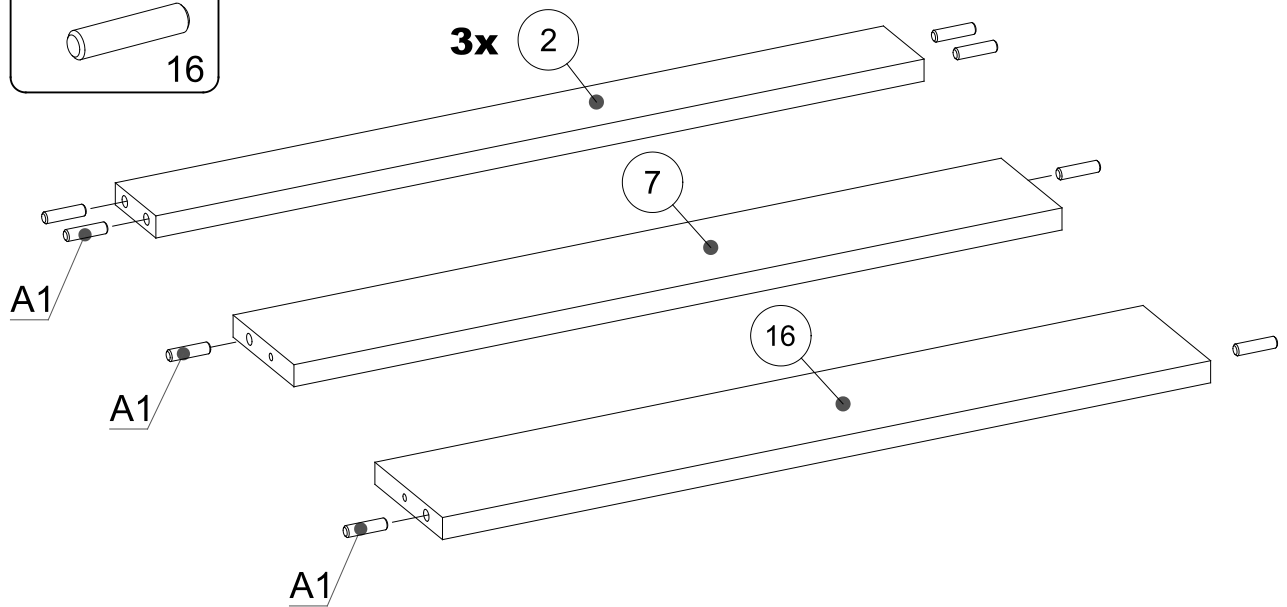
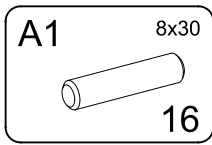

▶ 4

DE Sie benötigen für die Montage:
 EN You need for fitting-up:
 PL Niezbędne do montażu:

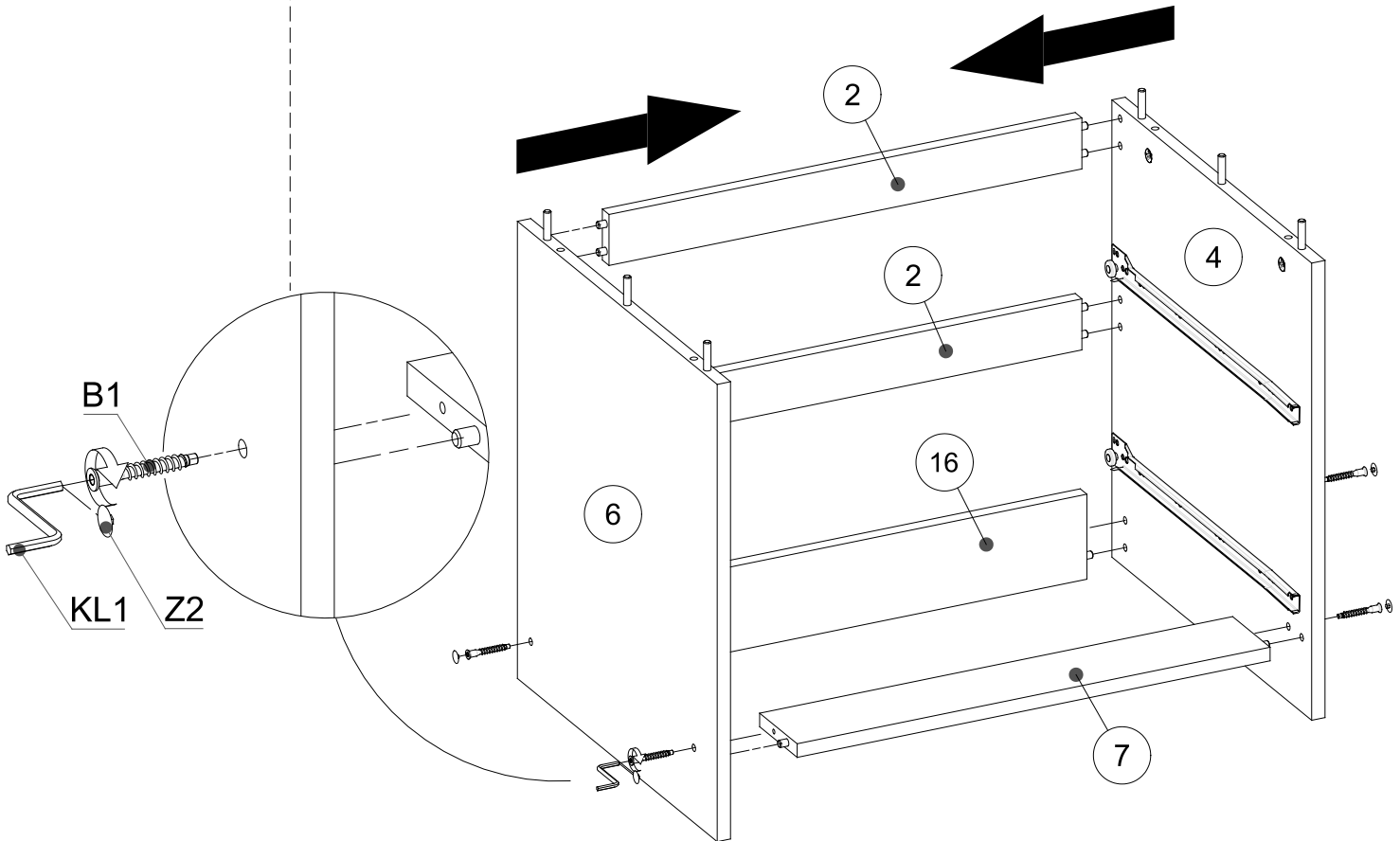
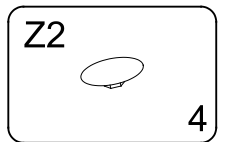
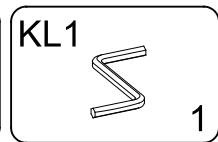
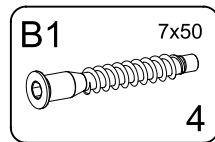
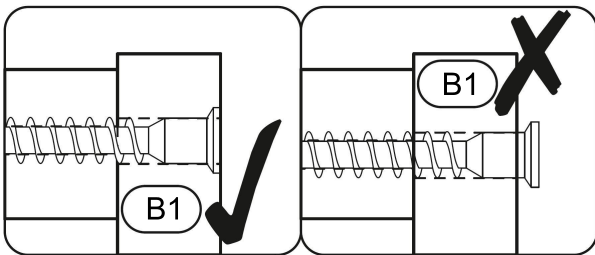

▶ 5

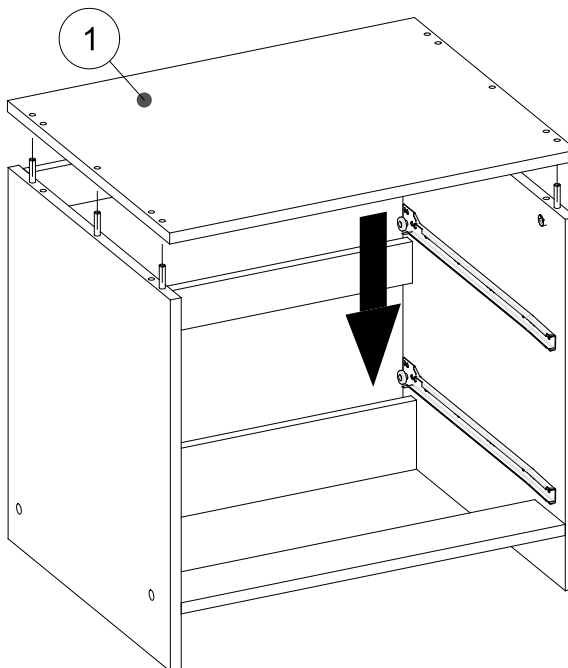
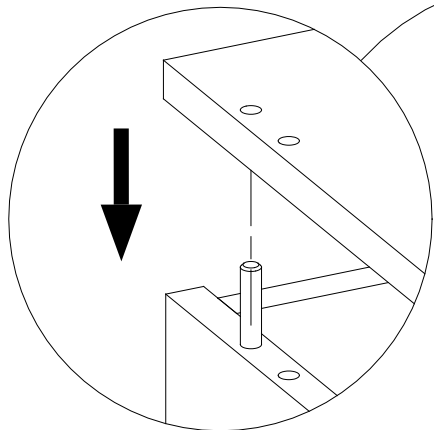

1)

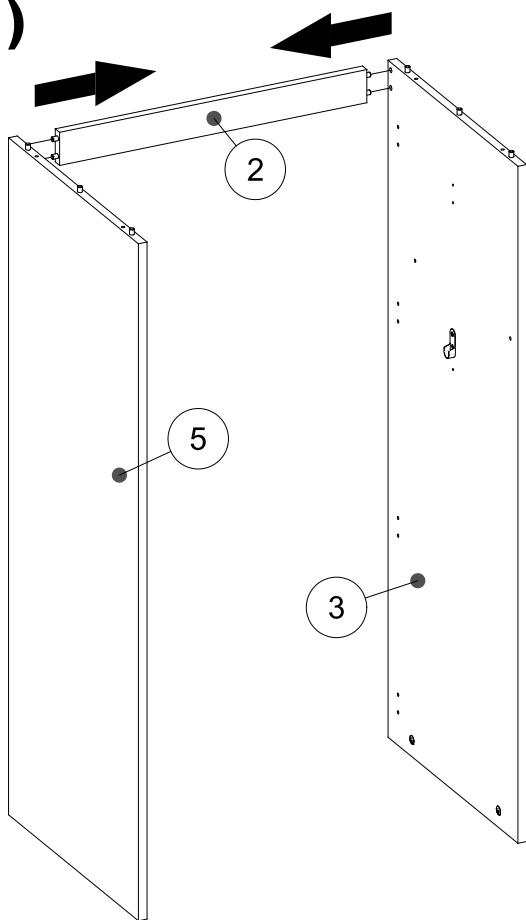

▶ 6

DE Sie benötigen für die Montage:
 EN You need for fitting-up:
 PL Niezbędne do montażu:

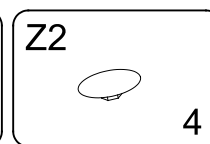
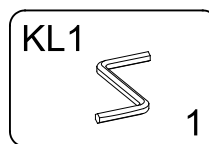
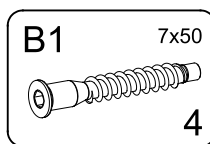
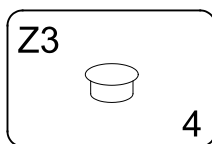

2)

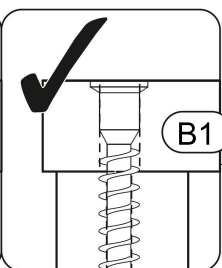
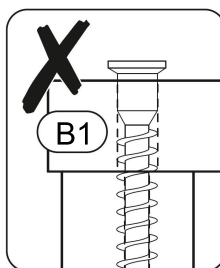
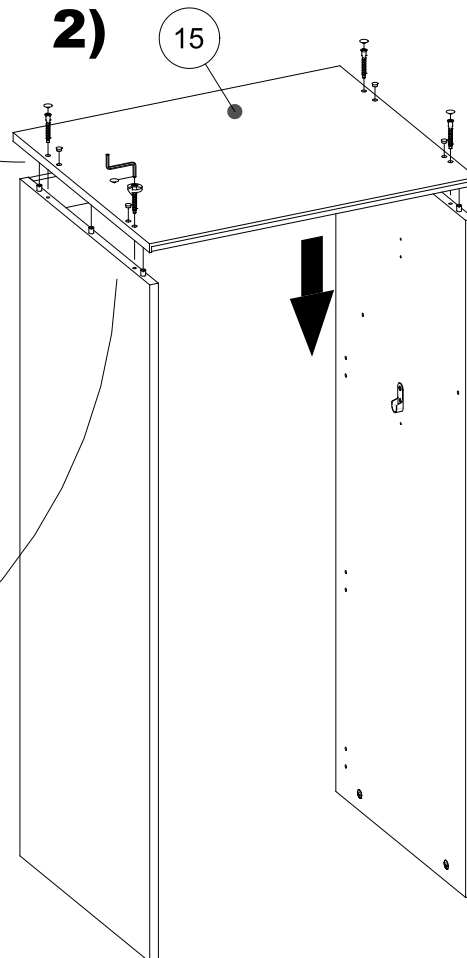
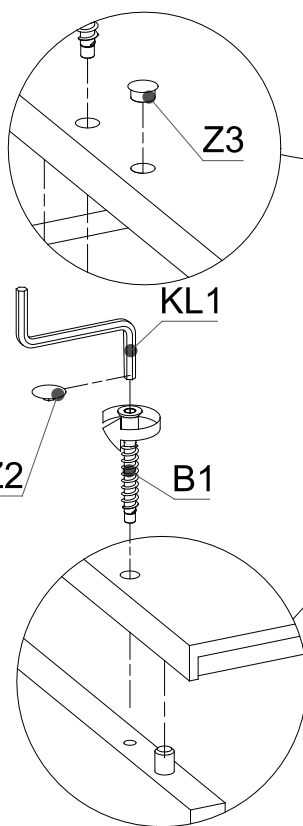

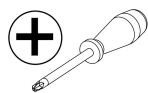
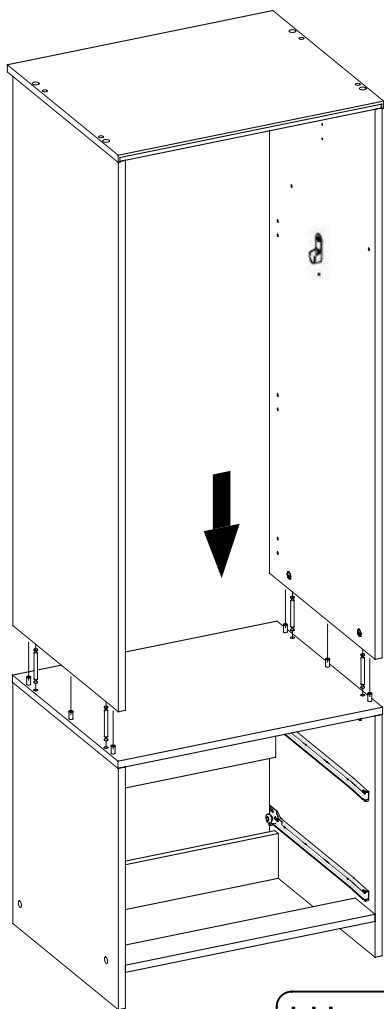

▶ 7

DE Sie benötigen für die Montage:
 EN You need for fitting-up:
 PL Niezbędne do montażu:

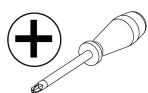
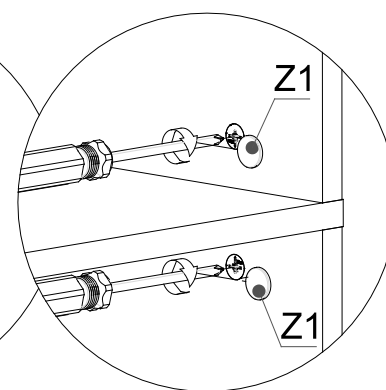
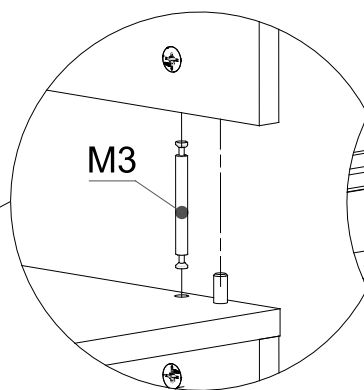
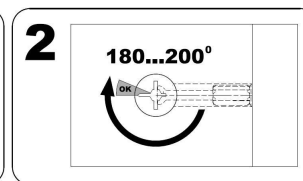
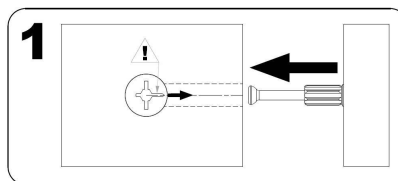
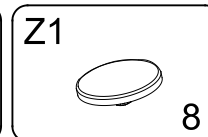
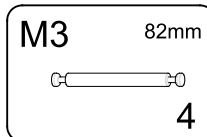

▶ 8

DE Sie benötigen für die Montage:
 EN You need for fitting-up:
 PL Niezbędne do montażu:

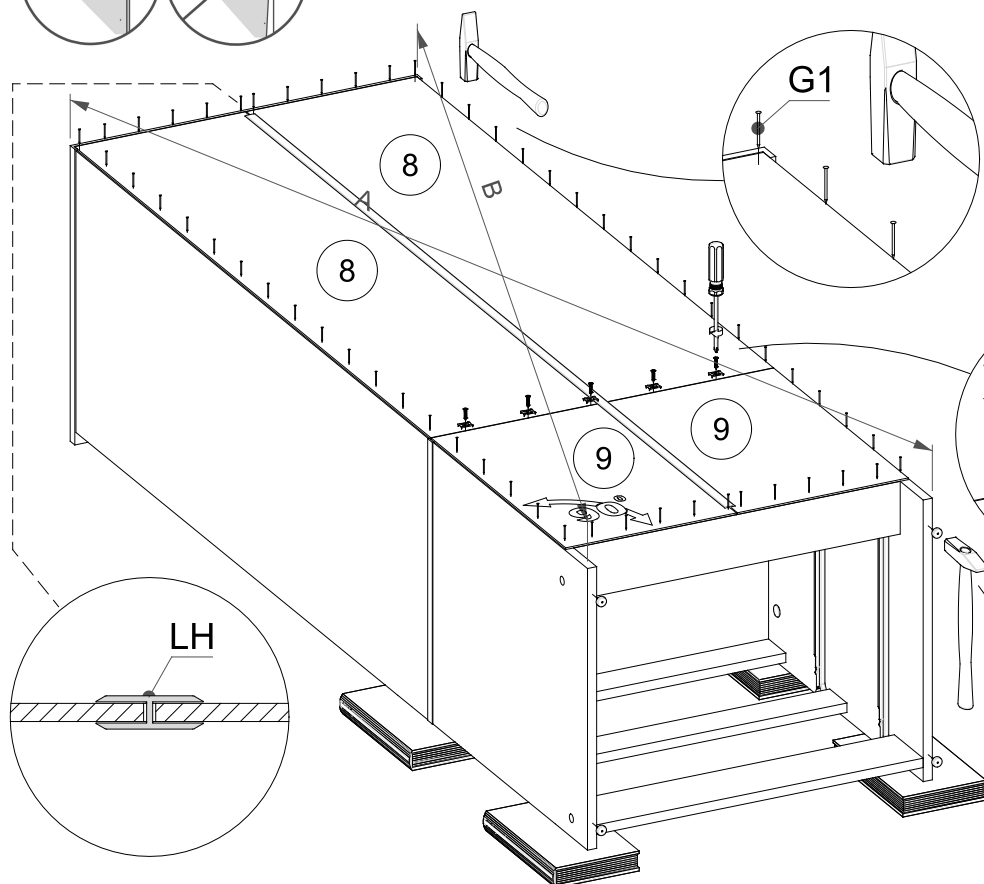
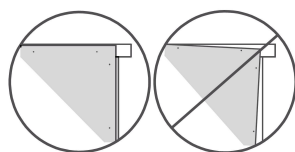
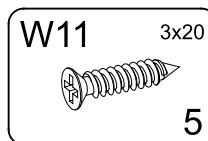
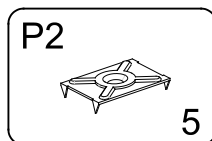
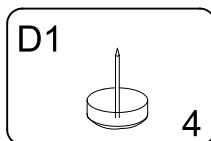
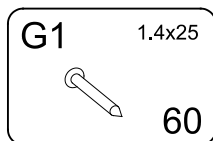
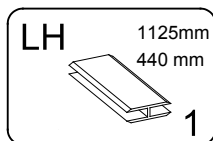

DE Länge A = Länge B
 EN Length A = Length B
 PL Długość A = Długość B

► **9** DE Sie benötigen für die Montage:
 EN You need for fitting-up:
 PL Niezbędne do montażu:

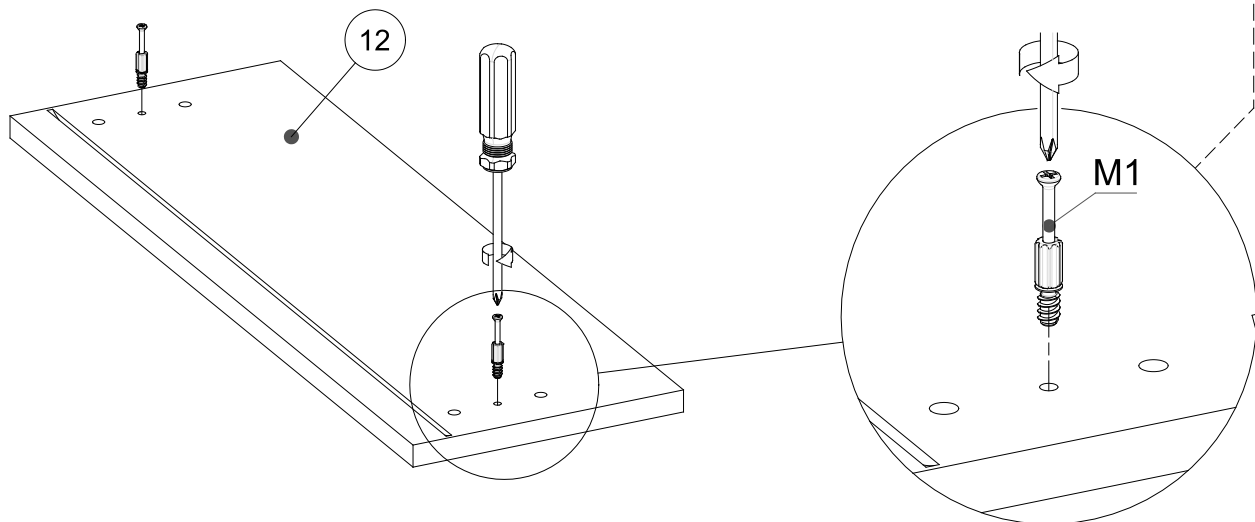
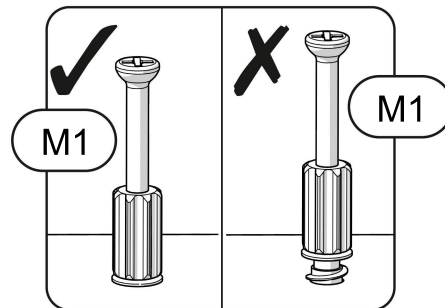
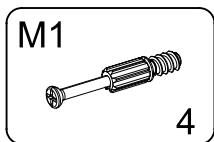
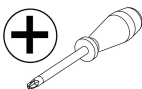

► **10** DE Sie benötigen für die Montage:
 EN You need for fitting-up:
 PL Niezbędne do montażu:

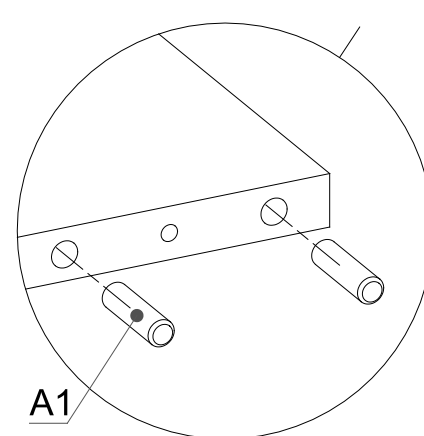
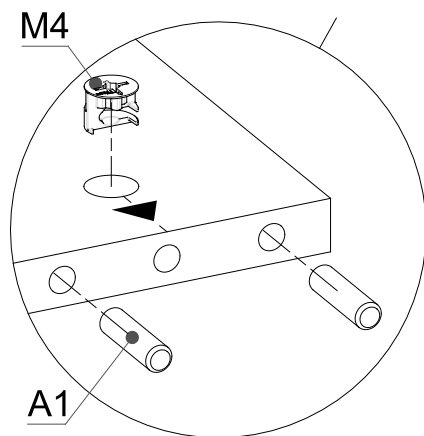
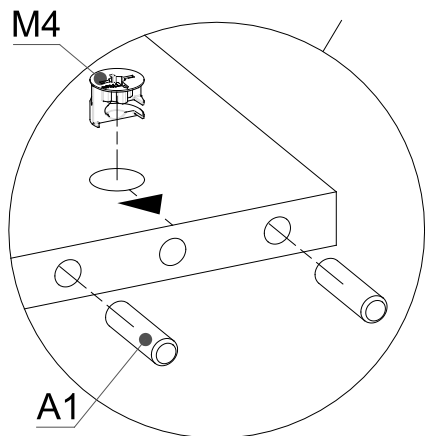
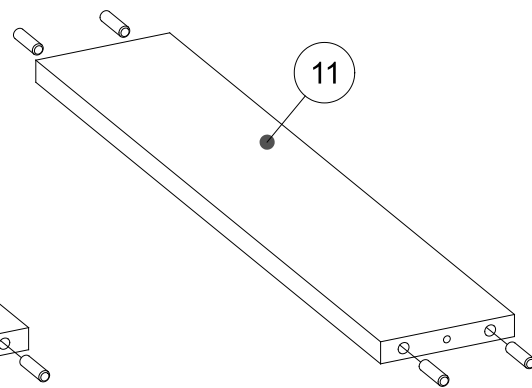
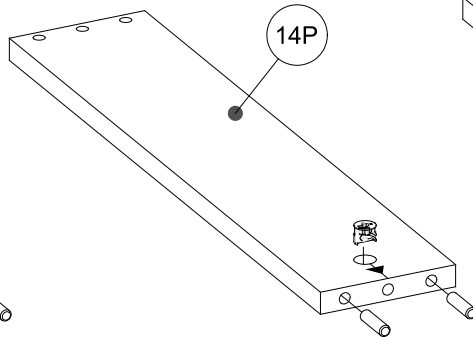
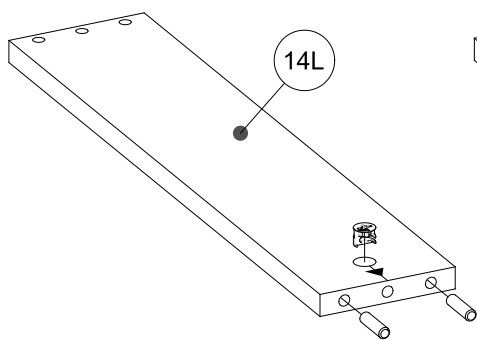
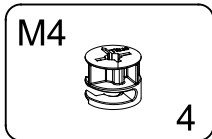
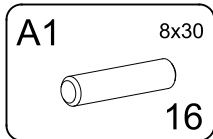

▶ 11 DE Sie benötigen für die Montage:
 EN You need for fitting-up:
 PL Niezbędne do montażu:

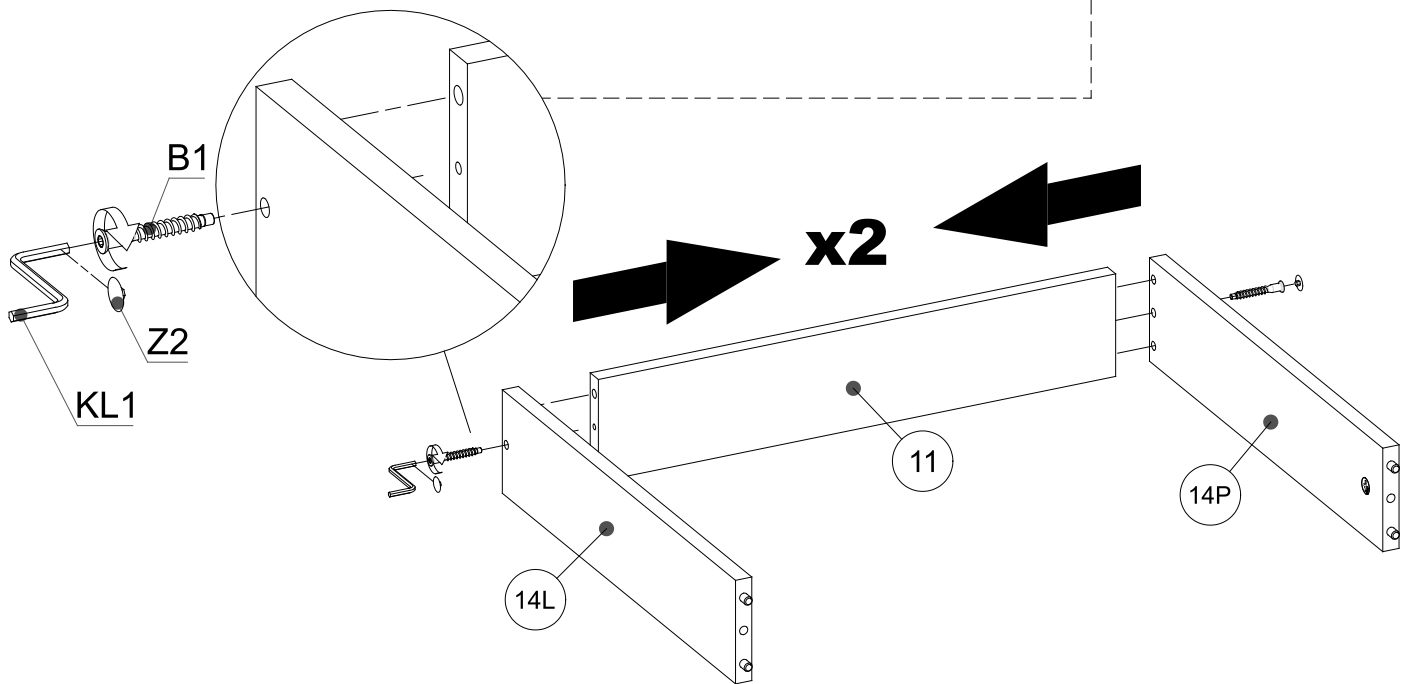
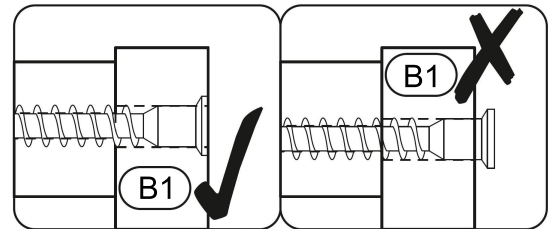
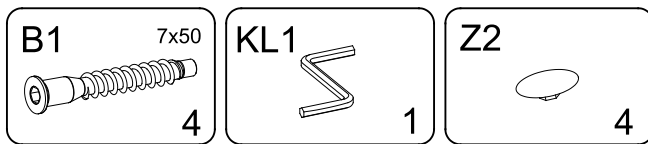

▶ 12 DE Sie benötigen für die Montage:
 EN You need for fitting-up:
 PL Niezbędne do montażu:

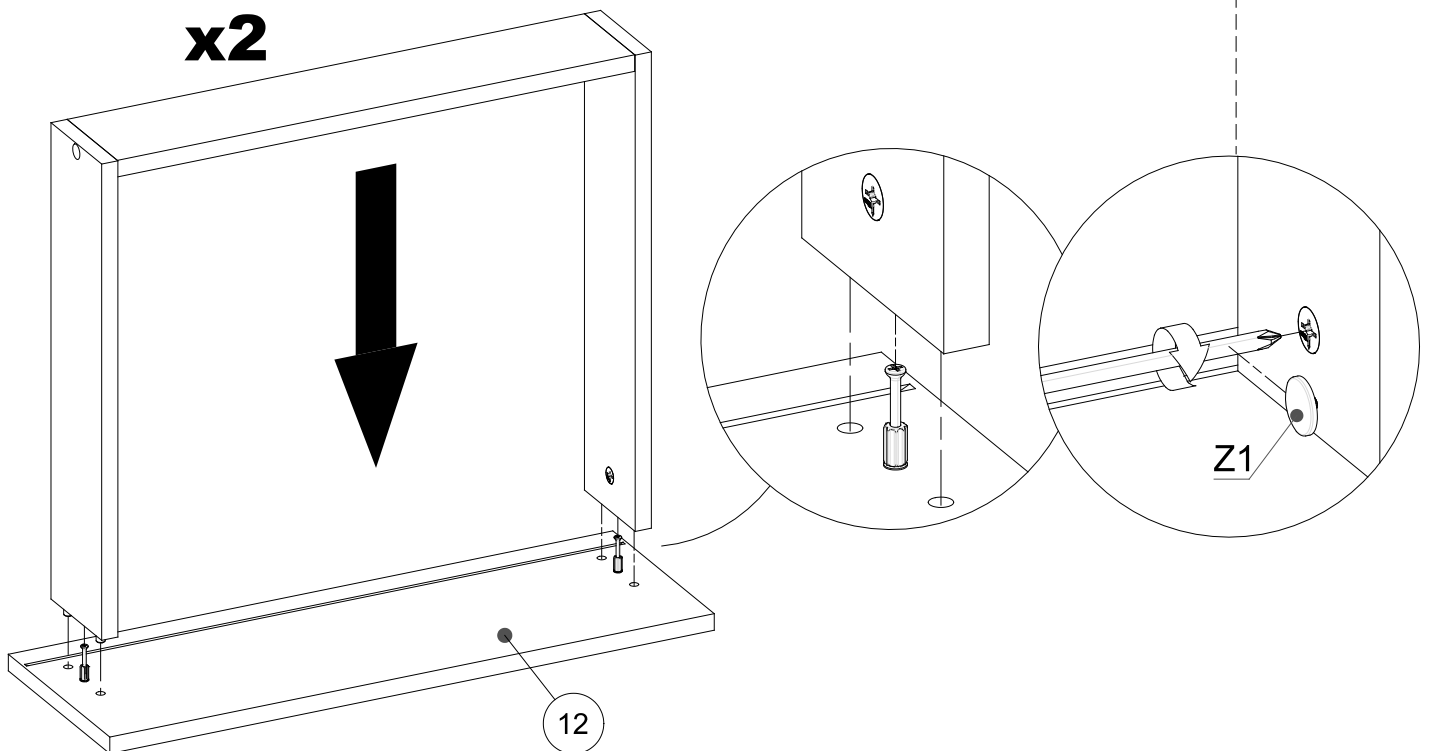
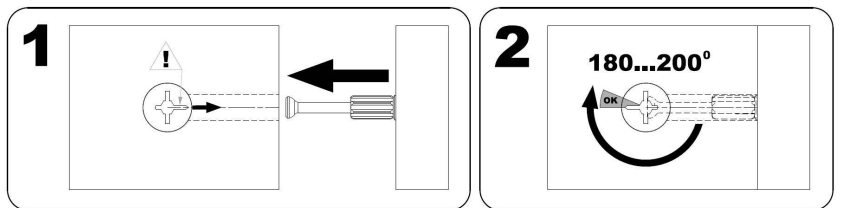
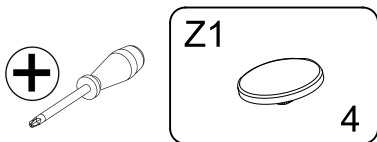

▶ 13

DE Sie benötigen für die Montage:
EN You need for fitting-up:
PL Niezbędne do montażu:

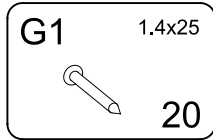

DE Länge A = Länge B
EN Length A = Length B
PL Długość A = Długość B

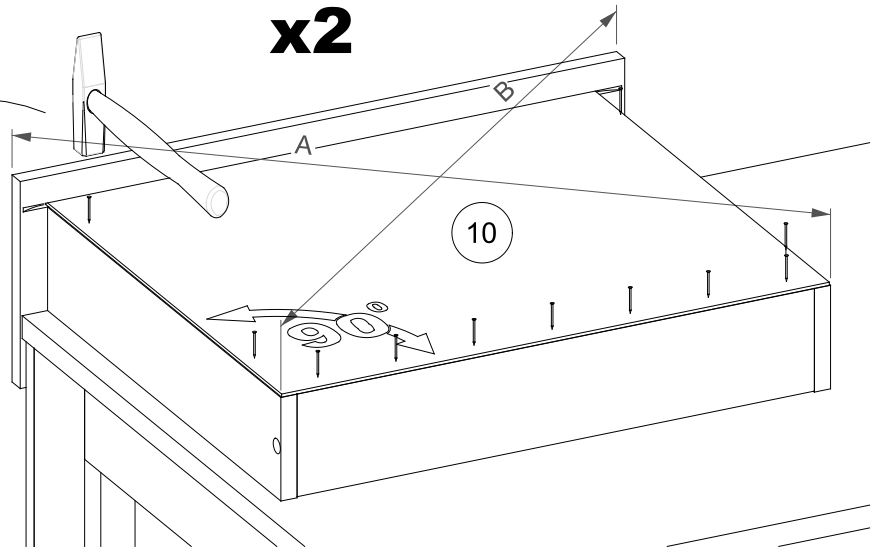
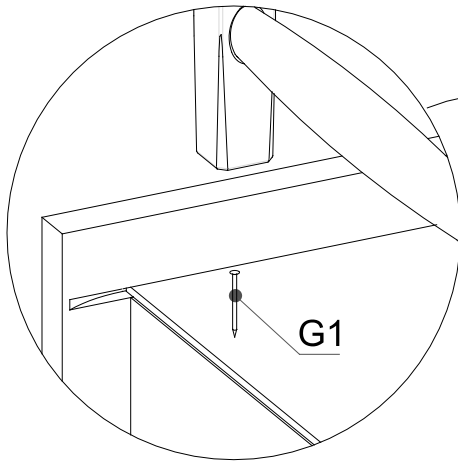

▶ 14

DE Sie benötigen für die Montage:
EN You need for fitting-up:
PL Niezbędne do montażu:

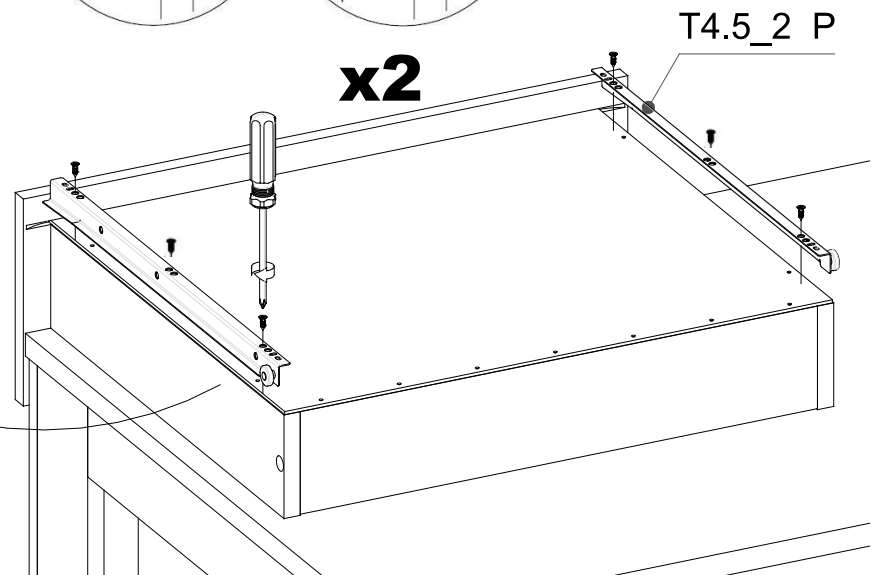
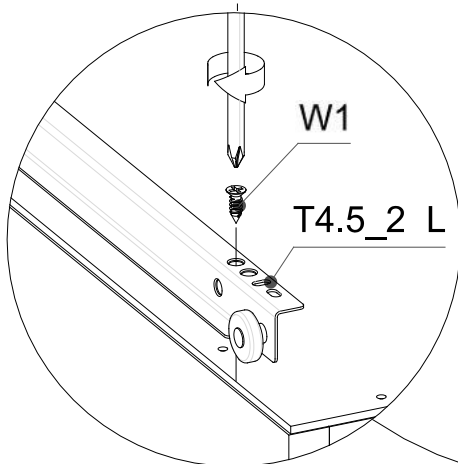
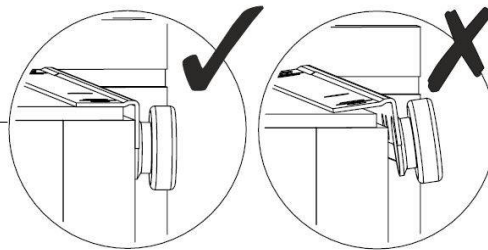
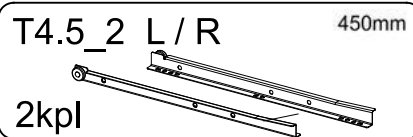
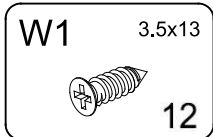
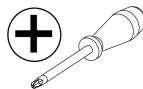

► 15

DE Sie benötigen für die Montage:
EN You need for fitting-up:
PL Niezbędne do montażu:

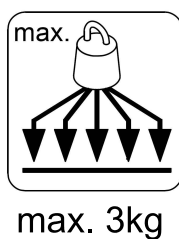
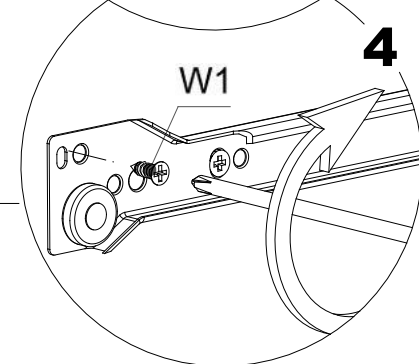
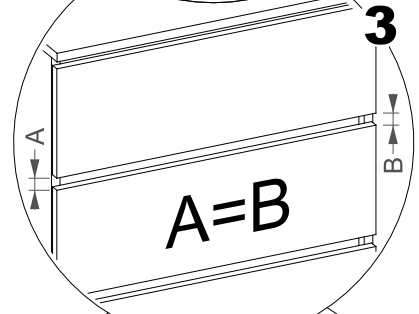
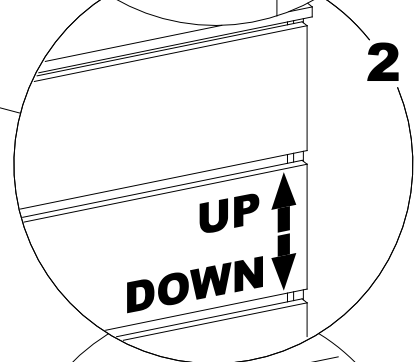
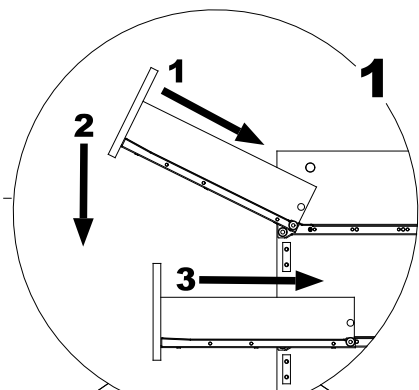
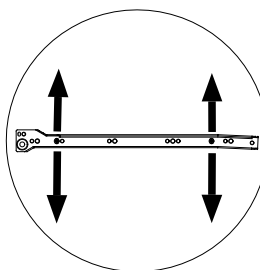
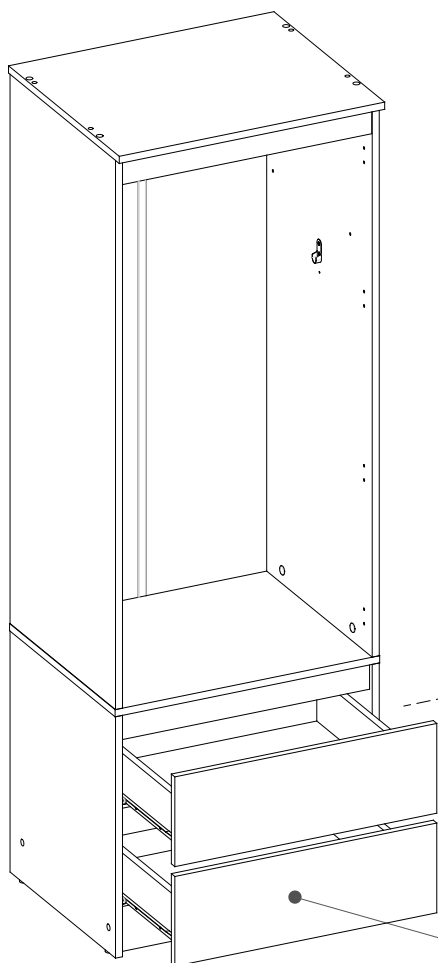
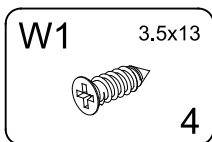
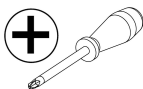

► 16

DE Sie benötigen für die Montage:
EN You need for fitting-up:
PL Niezbędne do montażu:

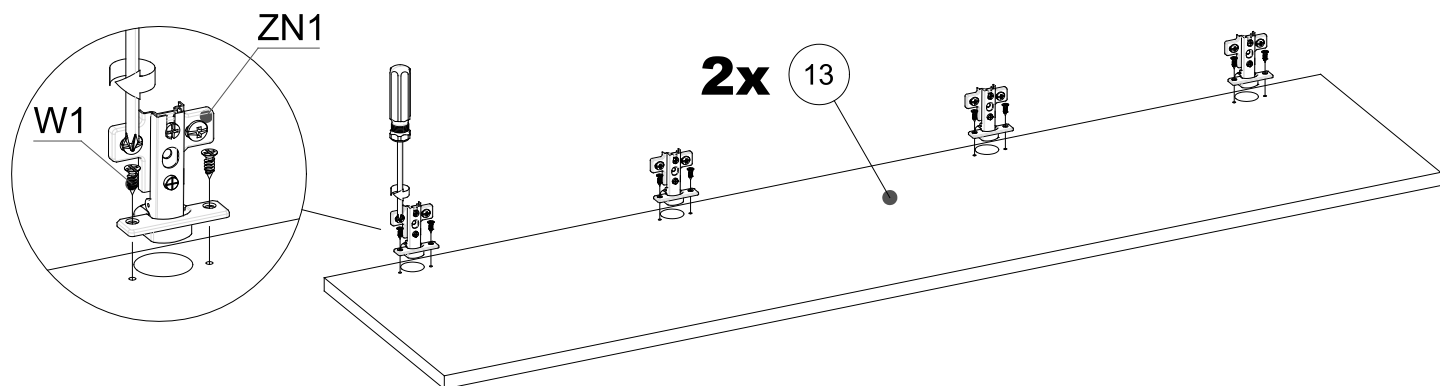
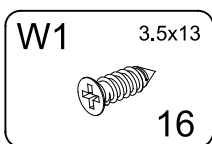
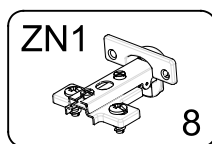

17 DE Sie benötigen für die Montage:
 EN You need for fitting-up:
 PL Niezbędne do montażu:

