

# Installation Instruction

SKU: N606P382993/N606P382994

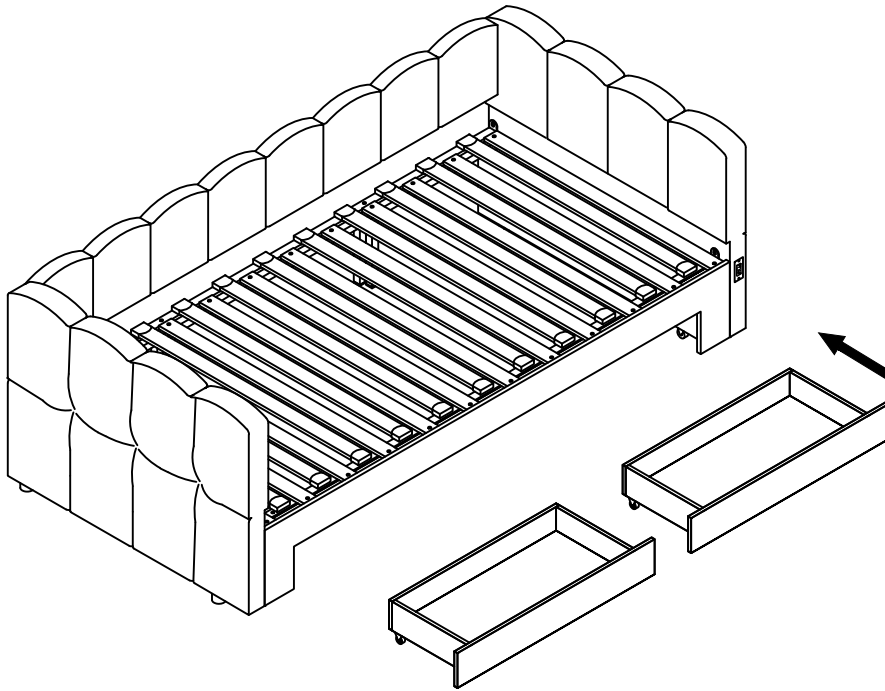

Our product will be delivered to you in 2 packages. The delivery times of these 2 packages may differ, please be patient and thank you for your understanding.

**UK  
CA**



## English

### IMPORTANT FOR GAS LIFT BEDS&MAINTAINANCE

- Please place the mattress on top of the bed frame.
- Please do not pull on the strap handles.
- Please press heavily to release the compressed gas.
- Periodically check all screw & fixings to ensure they are secure.
- When moving your product, carefully lift into place.
- Wipe clean with a slightly damp cloth- please do not use abrasive chemicals or bleach.
- Do NOT allow children to operate the lift mechanism.
- Do NOT allow children near the lift base when operating the mechanism.
- Do NOT stand inside the bed or the internal storage base.
- Do NOT overload the internal storage base.
- DO NOT jump on the product or any of its parts.

## Deutsch

### WICHTIG FÜR GASLIFT-BETTEN&WARTUNG

- Bitte legen Sie die Matratze oben auf den Bettrahmen.
- Bitte ziehen Sie nicht an den Gurtgriffen.
- Bitte drücken Sie kräftig, um das komprimierte Gas freizusetzen.
- Überprüfen Sie regelmäßig alle Schrauben und Befestigungen, um sicherzustellen, dass sie sicher sind.
- Wenn Sie Ihr Produkt bewegen, heben Sie es vorsichtig an seinen Platz.
- Mit einem leicht feuchten Tuch abwischen - bitte keine scheuernden Chemikalien oder Bleichmittel verwenden.
- Erlauben Sie Kindern NICHT, den Hebemechanismus zu bedienen.
- Lassen Sie Kinder NICHT in die Nähe des Liftsockels, wenn Sie den Mechanismus bedienen.
- Stellen Sie sich NICHT in das Bett oder in die Innenablage.
- Überlasten Sie den internen Liftsockel NICHT.
- Springen Sie NICHT auf das Produkt oder eines seiner Teile.

## Français

### IMPORTANT POUR LES LITS À RELEVAGE DE GAZ&MAINTENANCE

- Veuillez placer le matelas sur le dessus du cadre de lit.
- Ne tirez pas sur les poignées de la sangle.
- Appuyez fortement pour libérer le gaz comprimé.
- Vérifiez régulièrement que toutes les vis et fixations sont bien en place.
- Lorsque vous déplacez votre produit, soulevez-le avec précaution pour le mettre en place.
- Nettoyez avec un chiffon légèrement humide - n'utilisez pas de produits chimiques abrasifs ou d'eau de Javel.
- Ne laissez pas les enfants utiliser le mécanisme de levage.
- Ne laissez pas les enfants s'approcher de la base de levage lorsqu'ils actionnent le mécanisme.
- Ne vous tenez PAS à l'intérieur du lit ou de la base de stockage interne.
- Ne surchargez pas la base de stockage interne.
- Ne pas sauter sur le produit ou l'une de ses parties.

## Italiano

### IMPORTANTE! CONSERVARE PER RIFERIMENTO FUTURO: LEGGERE ATTENTAMENTE

- Deve essere assemblato da un adulto. L'assemblaggio deve essere controllato da un adulto prima dell'uso
- **ATTENZIONE!** Tenere tutte le viti, le piccole parti e i sacchetti di plastica fuori dalla portata dei bambini
- Identificare correttamente tutte le parti prima dell'assemblaggio
- Non utilizzare mai l'articolo se alcune parti sono rotte o mancanti
- In caso di problemi, si prega di contattare il nostro Servizio Post Vendita
- Le istruzioni del produttore devono essere sempre seguite
- Cura: Pulire con un panno morbido e asciutto. In caso di macchie più estese, strofinare accuratamente con una spugna leggermente umida e nonspugna leggermente umida e non abrasiva
- Evitare il rischio di incendio, non collocando i mobili vicino a fonti di accensione o a oggetti caldi
- Non saltare sul letto

## Español

### ¡ IMPORTANTE ! CONSERVELO PARA FUTURAS CONSULTAS: LEA ATENTAMENTE

- Debe ser montado por un adulto. El montaje debe ser comprobado por un adulto antes del uso
- ADVERTENCIA Mantenga todos los tornillos, piezas pequeñas y bolsas de plástico fuera del alcance de los niños.
- Identifique correctamente todas las piezas antes de montarlas
  - Nunca utilice su artículo si alguna de sus piezas está rota o falta
  - Si surge algún problema, póngase en contacto con nuestro Servicio Postventa
  - Las instrucciones del fabricante deben seguirse en todo momento
  - Cuidado: Limpiar con un paño suave y seco. En caso de manchas más grandes, frote cuidadosamente con una esponja no abrasiva ligeramente humedecida.
  - Evite el riesgo de incendio no colocando los muebles cerca de fuentes de ignición u objetos calientes.
  - No saltar sobre la cama.

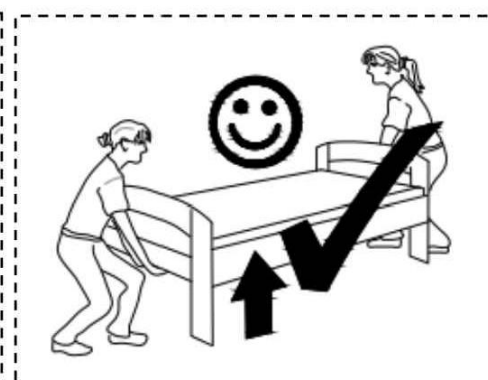
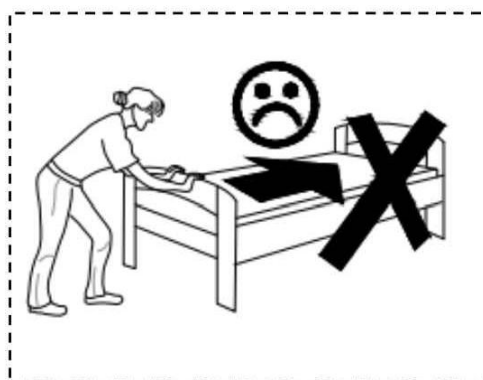

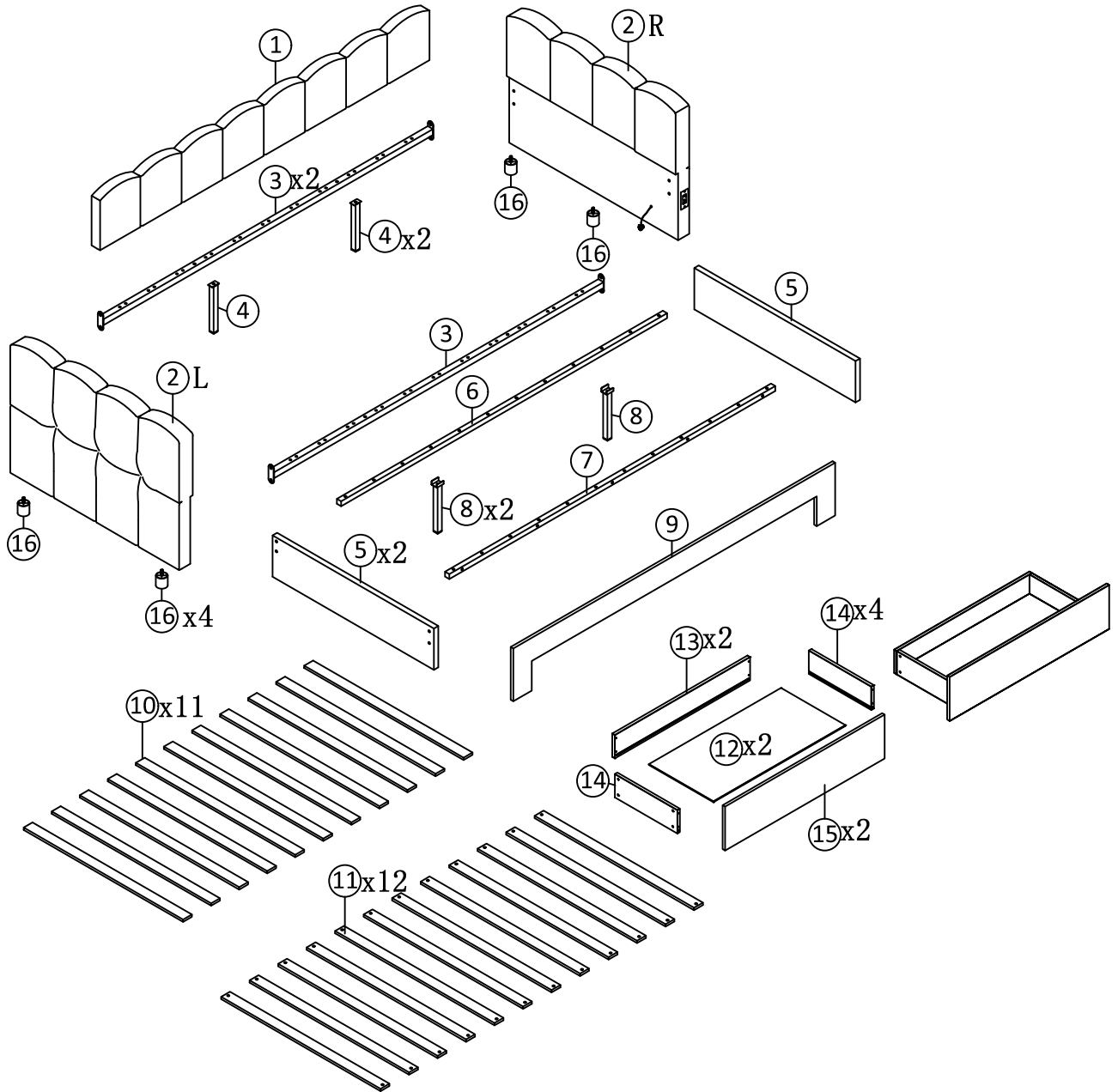

# Detail View





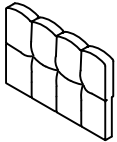
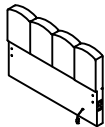
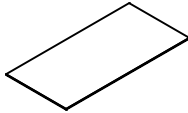
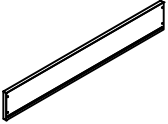
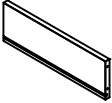

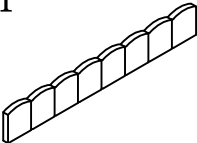

# Part List

## N606P382994

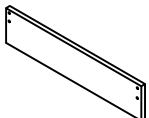

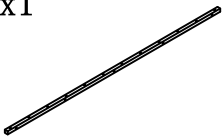
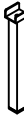
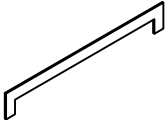

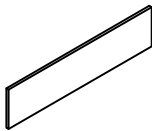











<p>②L x1</p> 	<p>②R x1</p> 	<p>⑫ x2</p> 	<p>⑬ x2</p> 
<p>Armrest</p>	<p>Armrest</p>	<p>Drawer bottom panel</p>	<p>Drawer board</p>
<p>⑭ x4</p> 	<p>⑯ x4</p> 		
<p>Drawer board</p>	<p>Bed legs</p>		

## N606P382993

<p>① x1</p> 	<p>③ x2</p> 	<p>④ x2</p> 	<p>⑤ x2</p> 
<p>Backrest</p>	<p>Metal side bar</p>	<p>Metal support leg</p>	<p>Side of the pull-out bed</p>
<p>⑥ x1</p> 	<p>⑦ x1</p> 	<p>⑧ x2</p> 	<p>⑨ x1</p> 
<p>Wooden side bar</p>	<p>Wooden side bar</p>	<p>Metal support leg</p>	<p>Front board</p>
<p>⑩ x11</p> 	<p>⑪ x12</p> 	<p>⑮ x2</p> 	
<p>Slats</p>	<p>Slats</p>	<p>Drawer outer board</p>	

# Hardware list

## N606P382994

Ax1 	Bx34  M8x18mm	Cx22  M8x25mm
Allen Key	Bolts	Bolts
Dx5  M8x40mm	Ex4  M8x45mm	Fx8  M3x16mm
Bolts	Bolts	Nails
Gx24  M3x20mm	Hx16 	Ix16 
Nails	Housing Accessories	Housing Accessories
Jx2 	Kx2 	Lx2 
Three-hole 7-shaped iron	"7" Connector	Four-hole iron sheet
Mx4 	Nx12 	Ox22 
Single-hole iron sheet	Wheel	Slat clip
Px8 		
Back plate clip		

**DE:** Vor dem Einbau die Schrauben in die Löcher stecken und festziehen, aber nicht bis 100%, 70% bis 80% anziehen reicht aus. Schließlich, nachdem alle Schrauben installiert sind, ziehen Sie alle Schrauben auf 100%.

Wenn Sie auf diese Probleme stoßen, wie z. B. Fehlausrichtung der Löcher oder Unfähigkeit, bestimmte Teile zu installieren, überprüfen Sie bitte, ob die Schrauben korrekt verwendet werden und passen Sie die Dichtigkeit der Schrauben an.

**UK:** Before installation, insert the screws into the holes and tighten them, but do not tighten them to 100%, 70% to 80% is sufficient. Finally, after all screws are installed, tighten all screws to 100%.

If you encounter these issues, such as if the holes cannot be aligned or some parts cannot be installed, please check if the screws are used correctly and adjust the tightness of the screws.

**FR:** Insérer la vis dans le trou avant la fin de l'assemblage, serrer la vis, mais ne pas serrer à 100%, 70% ~ 80% est correct. Enfin, une fois que toutes les vis sont bien serrées, toutes les vis sont serrées à 100%.

Si vous rencontrez ces problèmes, par exemple si les trous ne sont pas alignés ou si certaines pièces ne peuvent pas être montées, vérifiez que les vis sont utilisées correctement et Ajustez leur serrage.

Attention: Do not tighten the screws before completing the entire installation. If you have any difficulty with the installation process, please feel free to contact us.

## Step 1:

Fix the Bed legs (16) to Armrest (2).

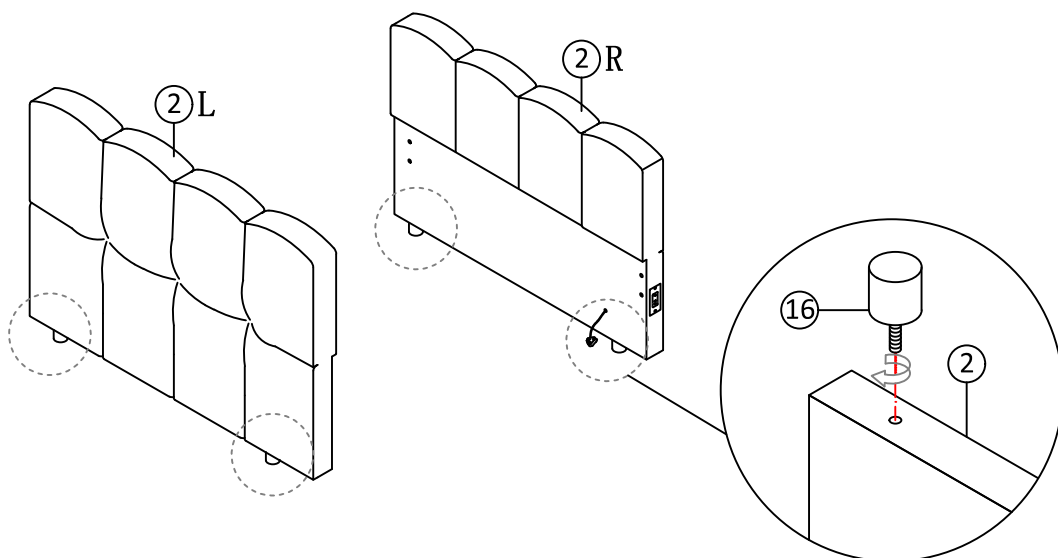

## Step 2:

Fix the Armrest (2) to the Backrest (1) with Bolts B and Four-hole iron sheet L by using Allen key A.

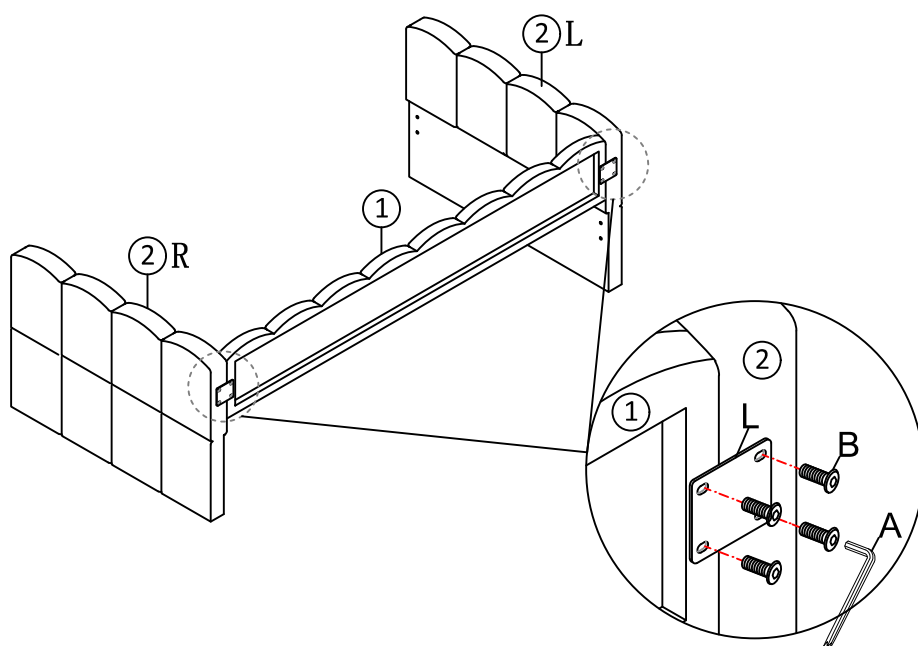

A Allen Key



B Bolts x 8



M8x18mm

L Four-hole iron sheet x 2



### Step 3:

Fix the Metal side bar (3) to the Armrest (2) with Bolts B by using Allen key A .

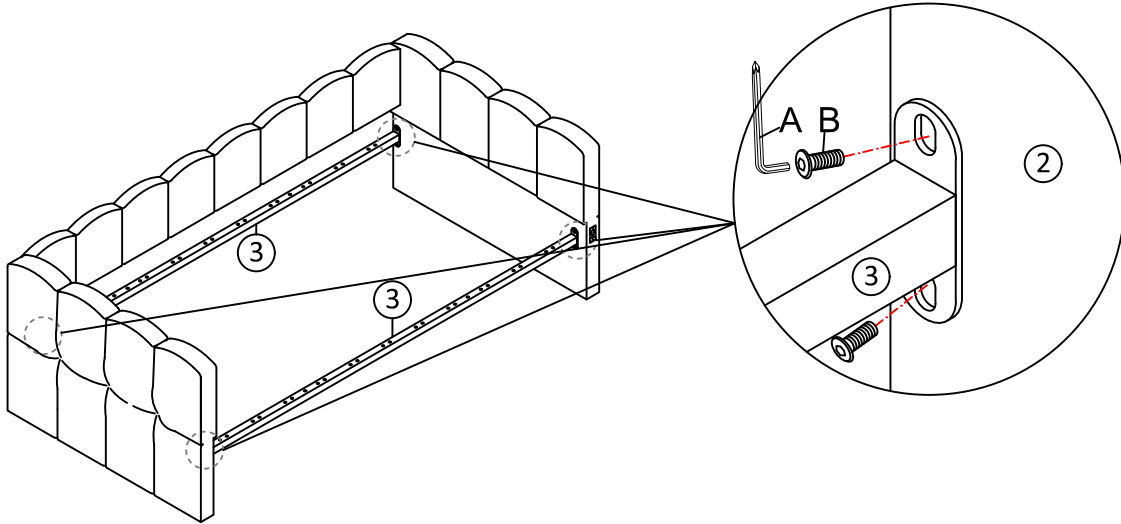

A Allen Key



B Bolts x 8



M8x18mm

### Step 4:

Fix the Metal support leg (4) to Metal side bar (3) with Bolts E by using Allen key A.

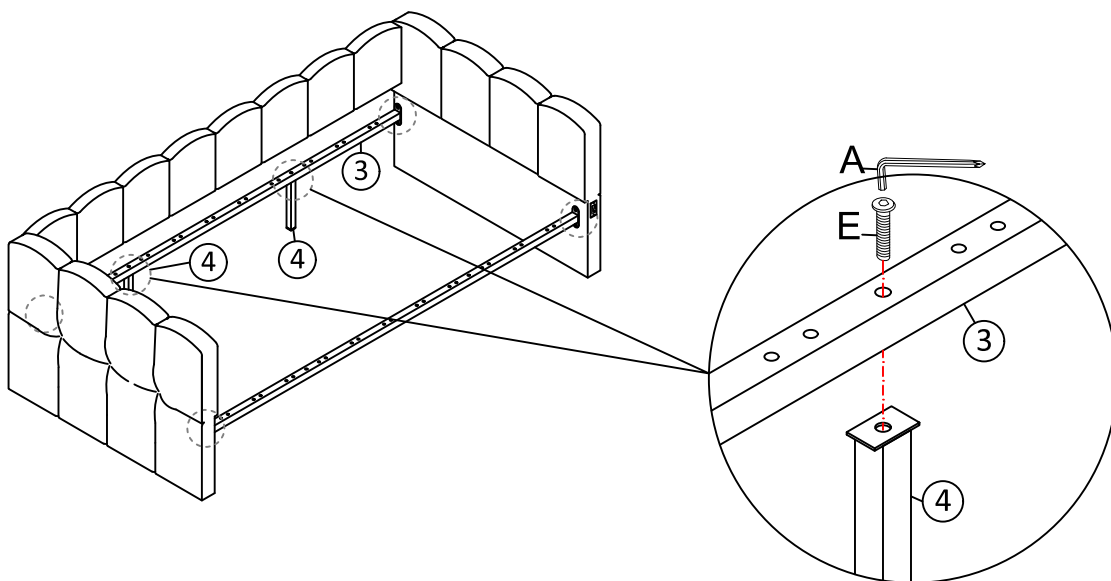

A Allen Key



E Bolts x 2



M8x45mm

## Step 5:

Fix the Single-hole iron sheet M to Front board ⑨ with Bolts B by using Allen key A.

Fix the "7" Connector K to Front board ⑨ with Bolts B by using Allen key A.

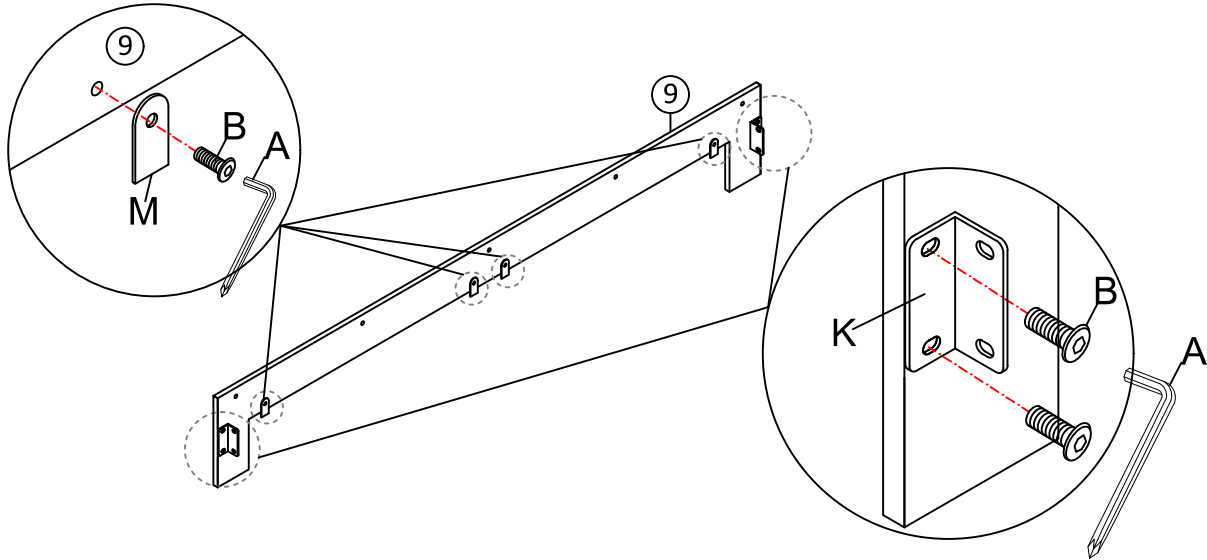

A Allen Key



B Bolts x 8



K "7" Connector  
x 2



M Single-hole iron  
sheet x 4



## Step 6:

Fix the Wheel N to the Side of the pull-out bed ⑤ with Nails G by using Allen key A.

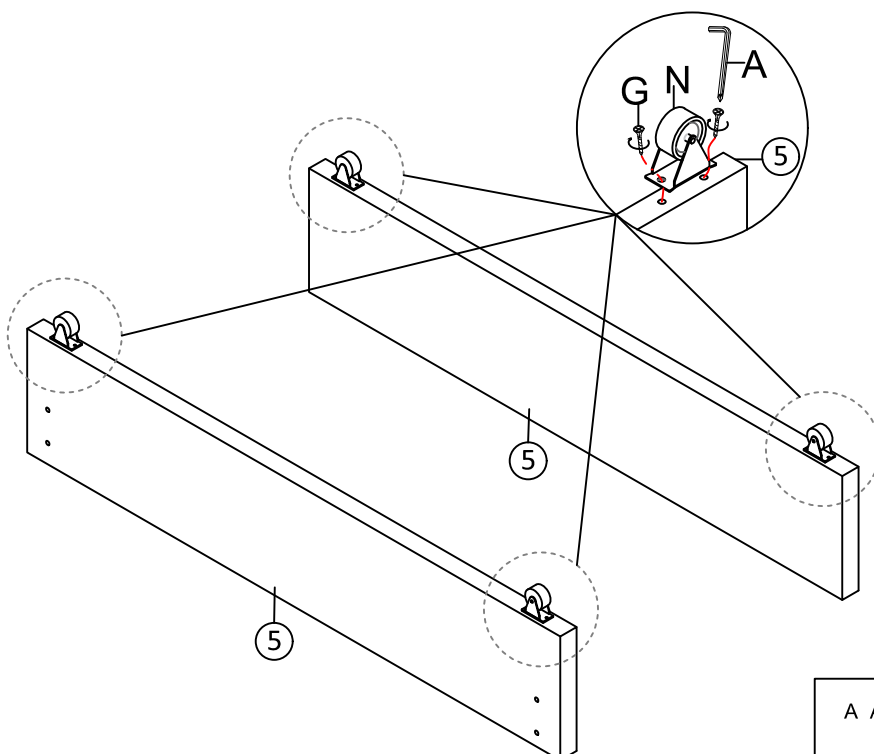

A Allen Key



G Nails x 8



N Wheel x 4



## Step 7:

Fix the Side of the pull-out bed ⑤ to "7" Connector K with Bolts B by using Allen key A.

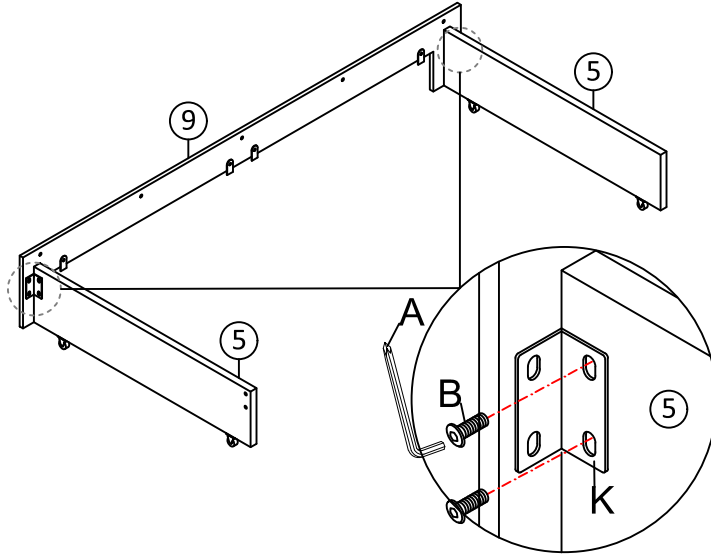

A Allen Key



B Bolts x 4



M8x18mm

## Step 8:

Fix the Wooden side bar ⑦ to Front board ⑨ with Bolts D by using Allen key A.

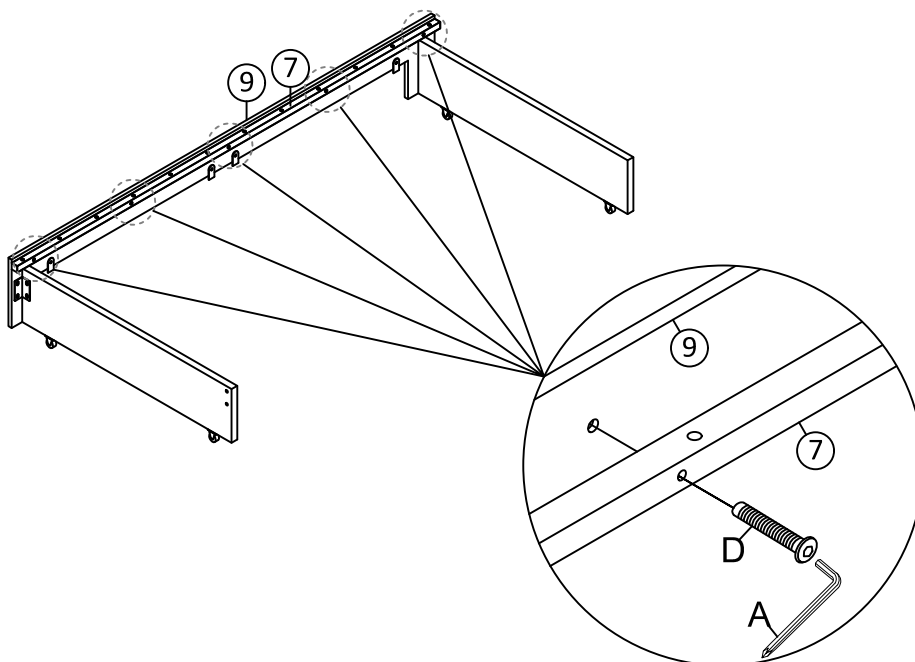

A Allen Key



D Bolts x 5



M8x40mm

## Step 9:

Fix the Three-hole 7-shaped iron J to Wooden side bar ⑥ with Bolts B by using Allen key A.

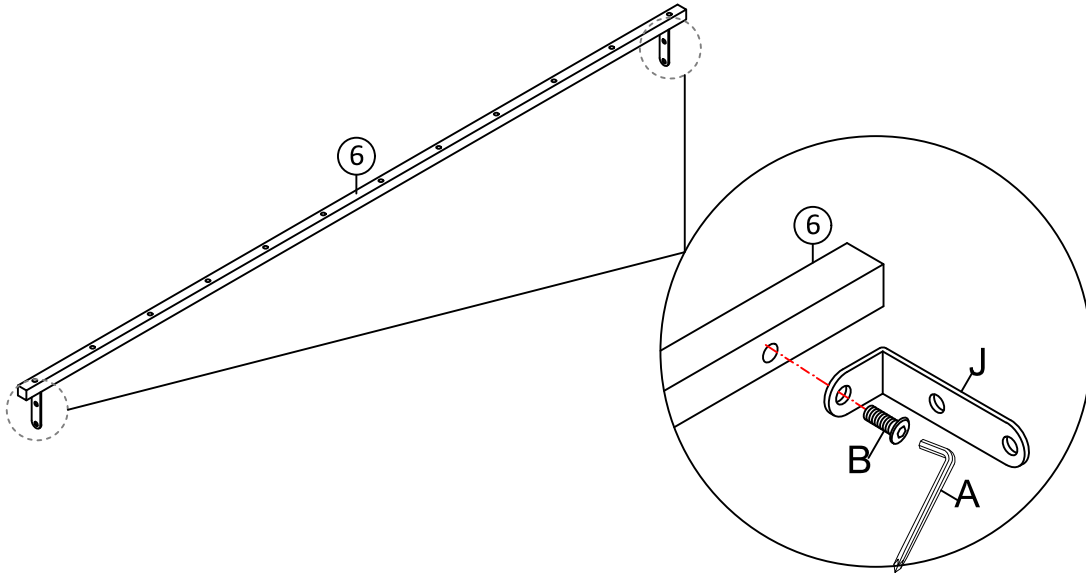

A Allen Key



B Bolts x 2



J Three-hole  
7-shaped iron x 2



## Step 10:

Fix the Side of the pull-out bed ⑤ to Three-hole 7-shaped iron J with Bolts B by using Allen key A.

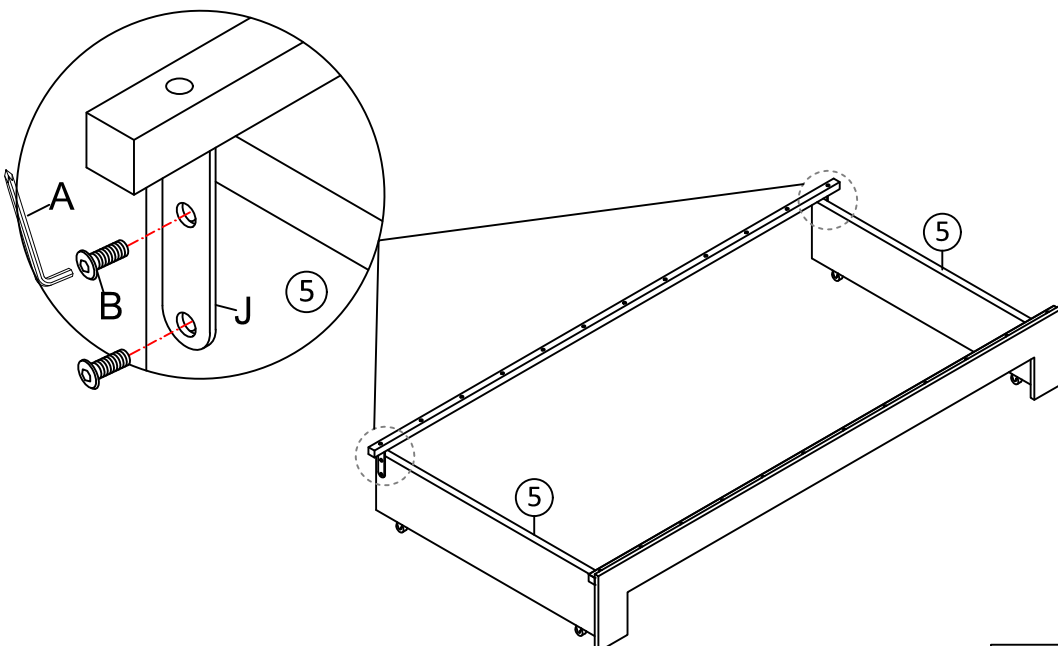

A Allen Key



B Bolts x 4



## Step 11:

Lift the upper bed and insert the pull-out bed into it.

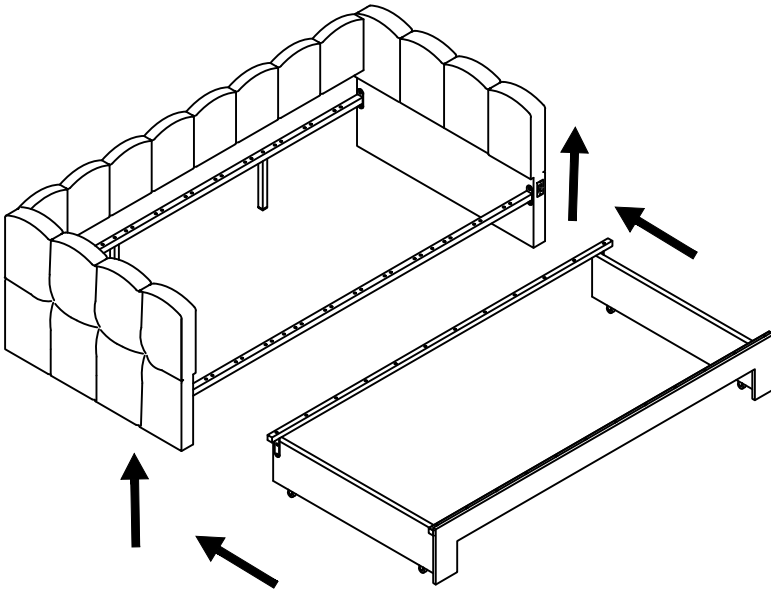

## Step 12:

Fix the Metal support leg ⑧ and Slats ⑪ to Wooden side bar ⑥ with Bolts E by using Allen key A.  
Fix the Slats ⑪ to Wooden side bar ⑥ and ⑦ with Bolts C by using Allen key A.

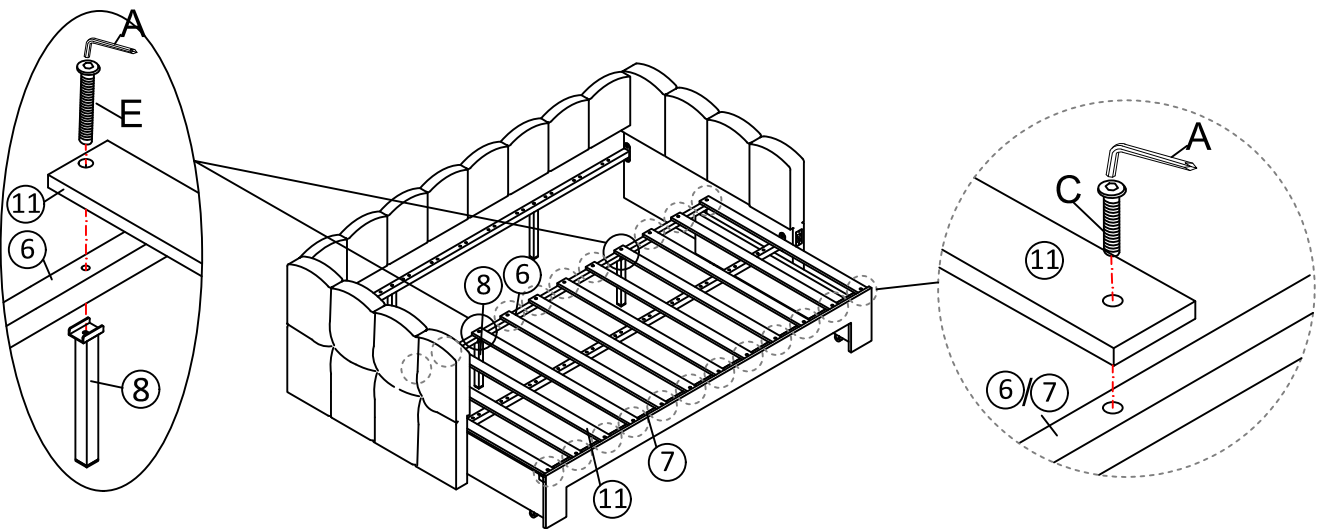

A Allen Key



C Bolts x 22



E Bolts x 2



### Step 13:

Assemble the slats into the assembled slats frame with End slats cap O.

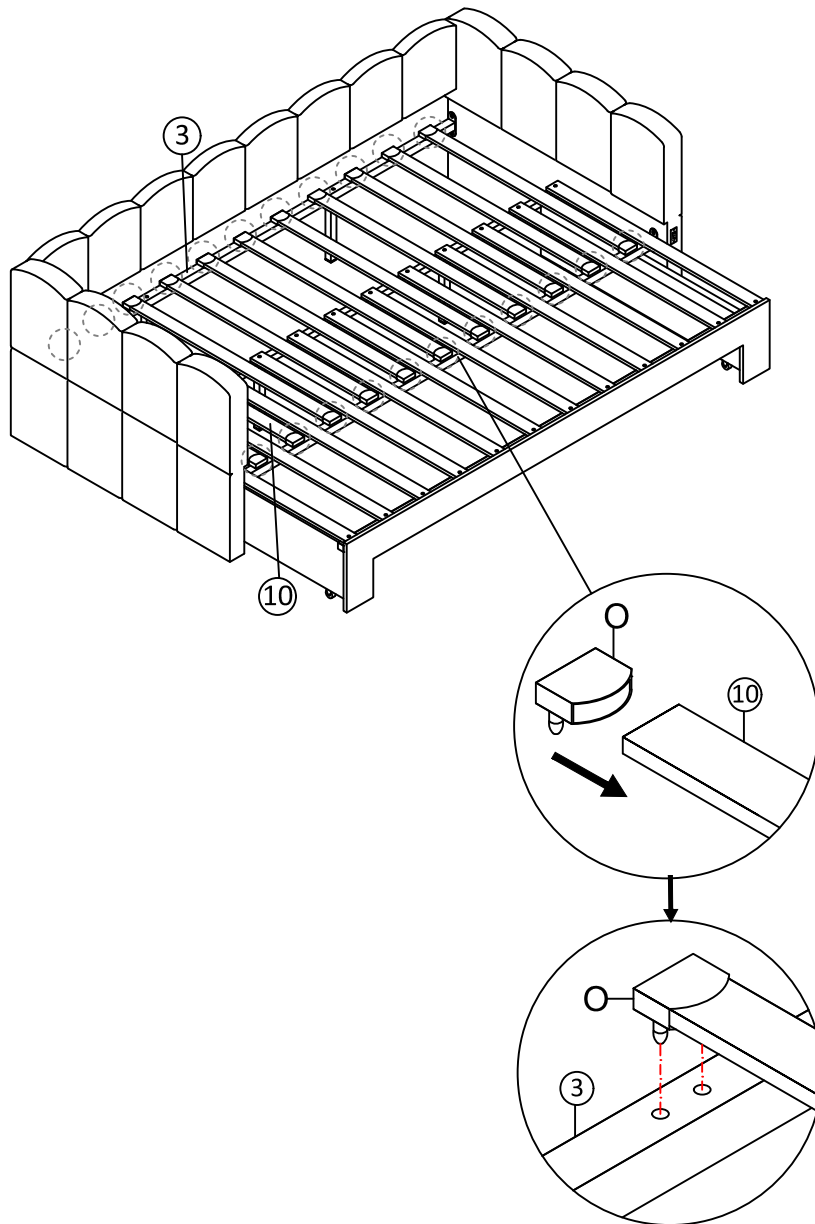

O End slats cap x 22



## Step 14:

Fix the Drawer fittings H to the Drawer out board (15) and Drawer board (13). Connect Drawer board (13) to (14) and (15) with Drawer Fittings I by using Allen key A. Fix Back plate clip P to the Drawer bottom panel with Nails F by using Allen Key A. Fix Wheel N to the bottom of the drawers with Nails G by using Allen Key A.

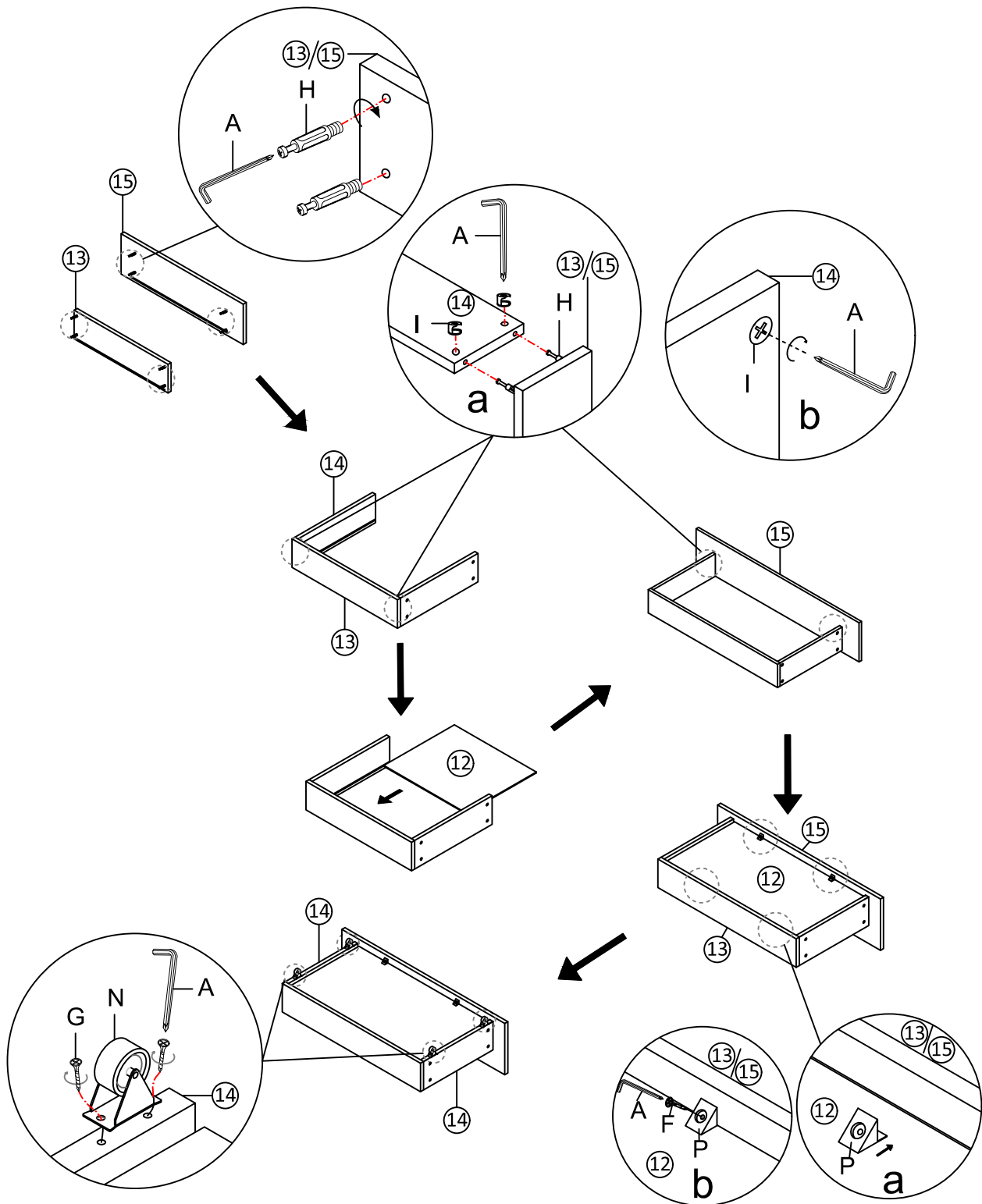

A Allen Key 	H Drawer fittings x 16 	I Drawer fittings x 16 	F Nails x 8 M3x16mm 	G Nails x 16 M3x20mm 	N Wheel x 8 	P Back plate clip x 8 
--	---	---	---	--	--	--

## Step 15:

Please connect to power.

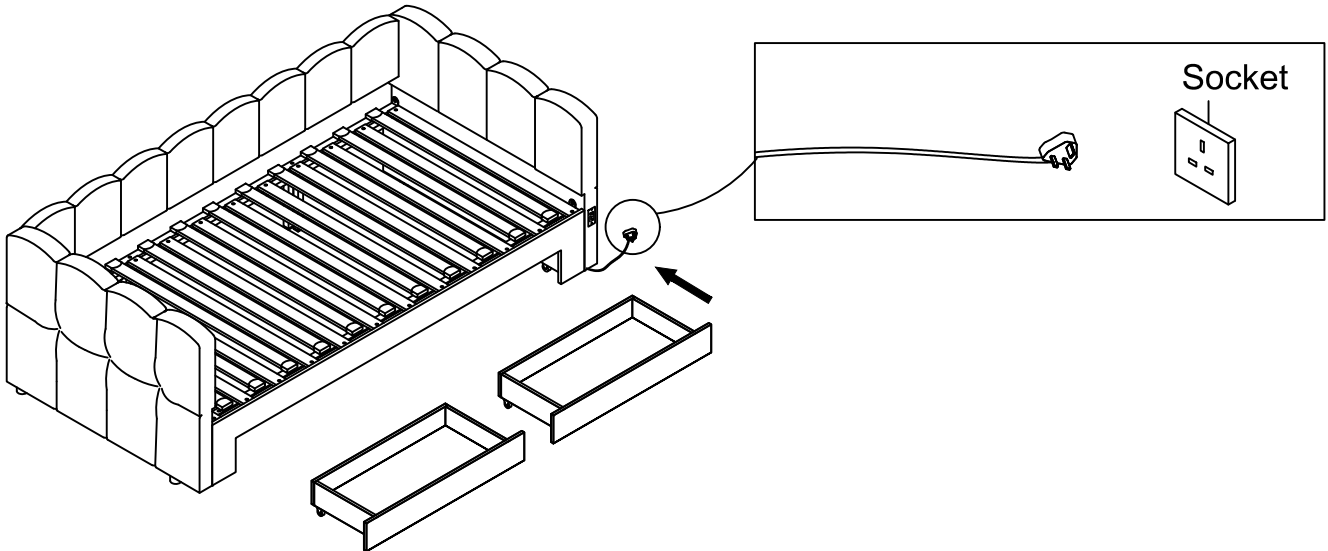

## Step 16:

Every thing is finished now, please enjoy your bed.

