

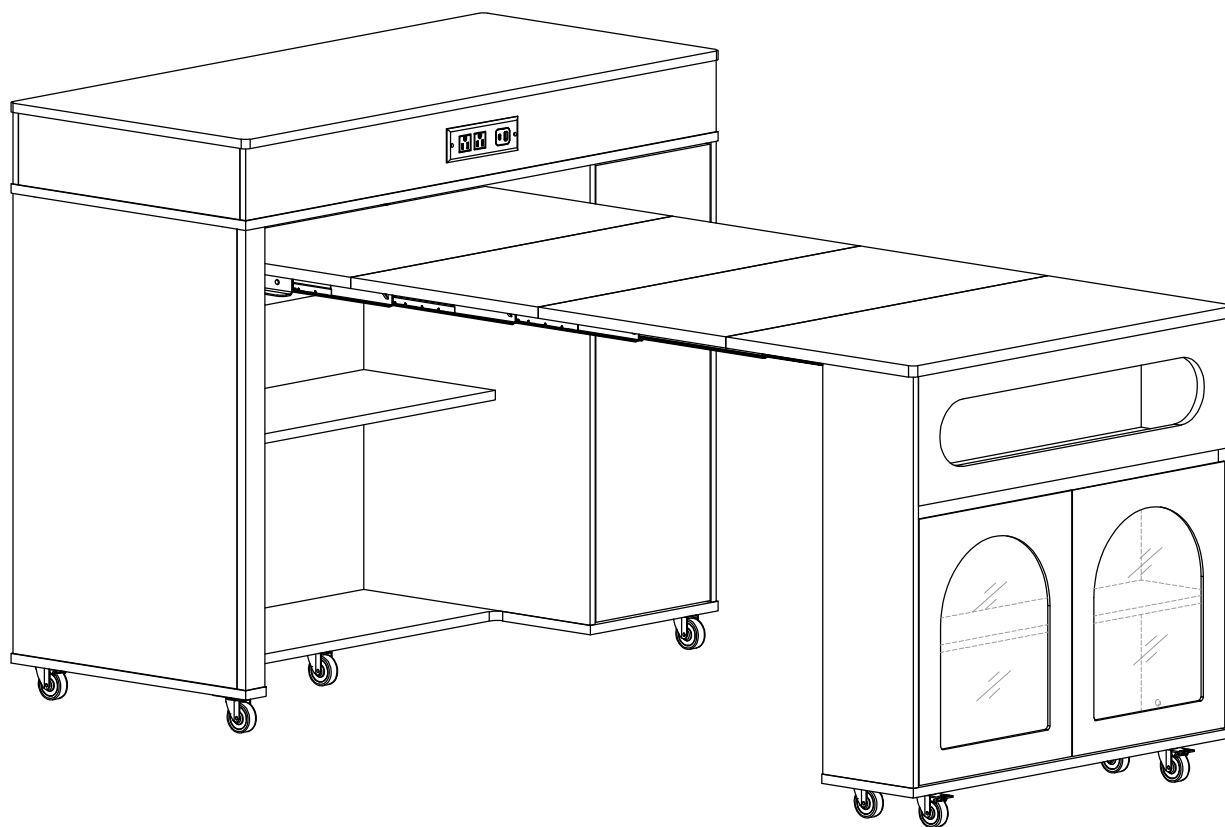

ASSEMBLY INSTRUCTION

EXTENDABLE TABLE



ASSEMBLY INSTRUCTION

Important - Please read these instructions fully before starting assembly

- Check you have all the components and tools listed on the following pages.
 - Remove all fittings from the plastic bags and separate them into their groups.
 - Keep children and animals away from the work area, small parts could choke if swallowed.
 - Make sure you have enough space to layout the parts before starting.
 - During assembly do not stand or put weight on the product, this could cause damage.
 - Assemble the item as close to its final position (in the same room) as possible.
 - Assemble on a soft level surface to avoid damaging the unit or your floor.
 - Parts of the assembly will be easier with 2 people.
-  To reduce the likelihood of damaging your product please ensure that your power drill is set on low torque setting.

Care and maintenance

- Only clean using a damp cloth and mild detergent, do not use bleach or abrasive cleaners.
- From time to time check that there are no loose screws on this unit.
- This product should not be discarded with household waste. Take to your local authority waste disposal centre.

Handy Hints

- Assemble all parts and bolts loosely during assembly, only once the product is complete should you fully tighten the bolts
- Regularly check and ensure that all bolts and fittings are tightened properly.

WARNING

In order to help prevent overturning - please follow these instructions

To help prevent product toppling over please follow the below steps:-

Use the anti tip strap or wall fixing method provided (if applicable)

Do not allow children to climb or hang on the furniture

Do not open more than one drawer at a time

Do not place heavy items in the top drawers

Do not place heavy items on top of the furniture, unless the furniture has been designed for this purpose

Please note that only the anti tip strap is provided.

You will need to provide wall plugs and screws applicable for your wall type

Tools required



Screwdrivers can be converted to Phillips and Slotted.

ASSEMBLY INSTRUCTION

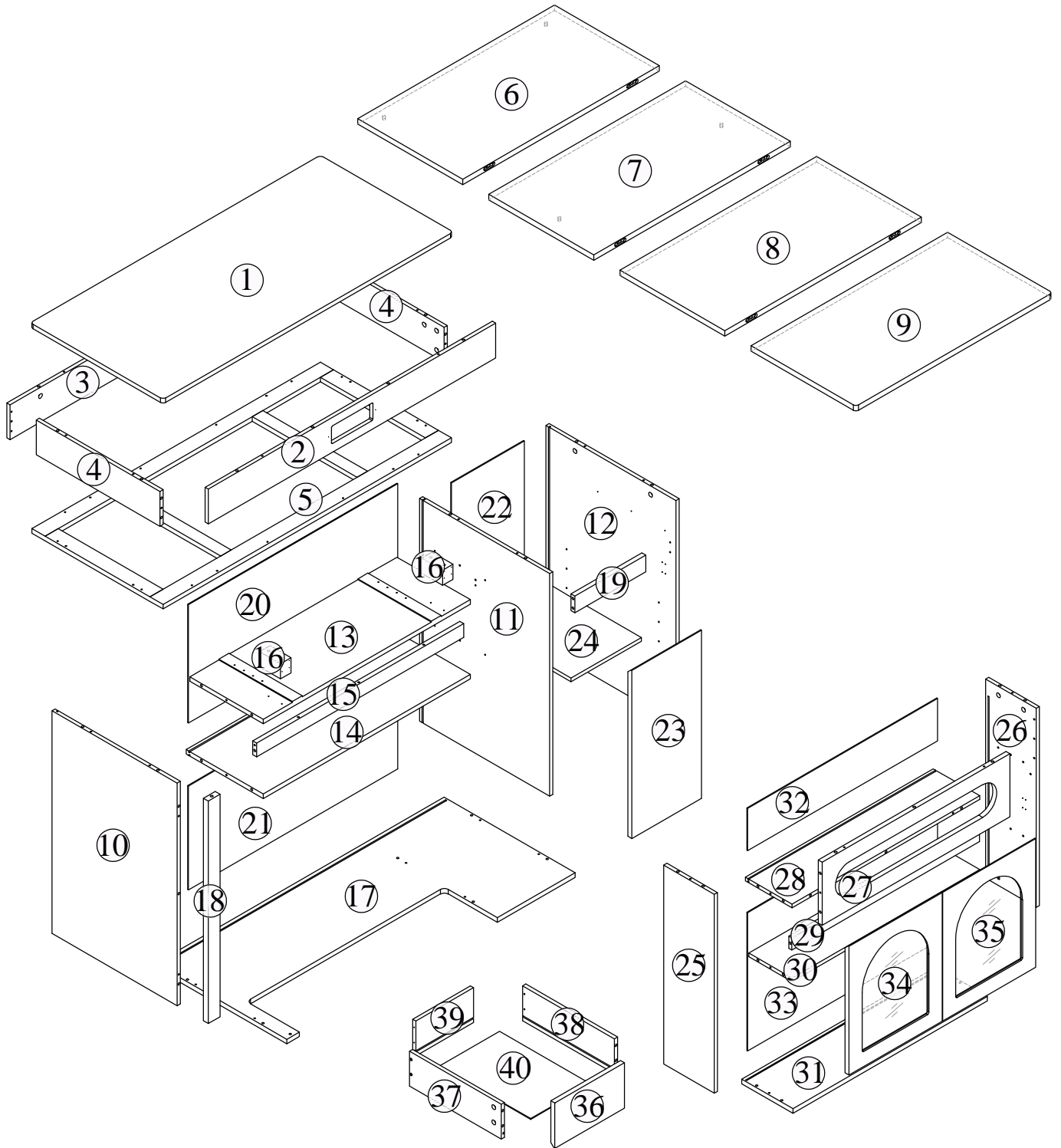



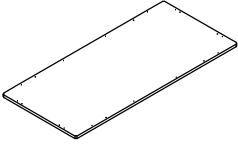
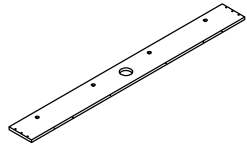
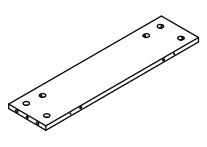
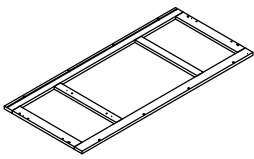
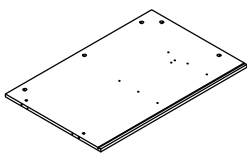
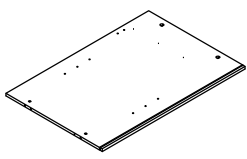
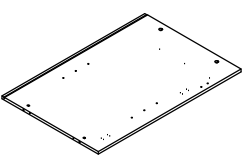
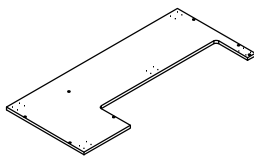
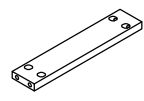
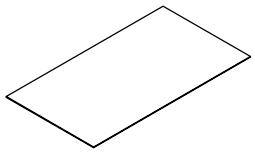
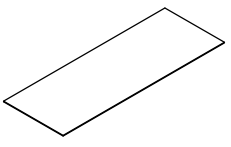
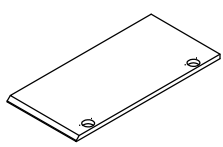
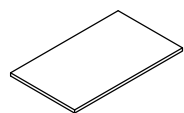
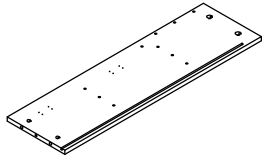
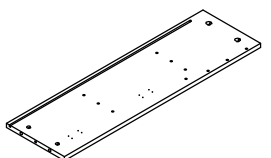
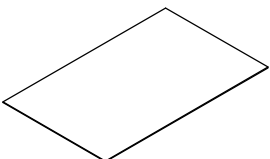
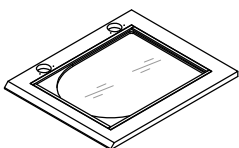
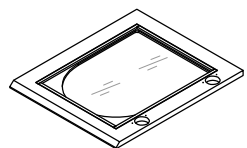
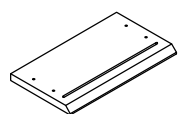
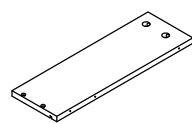
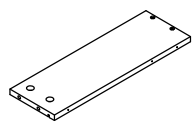
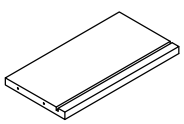
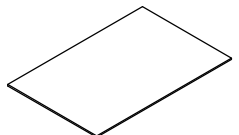



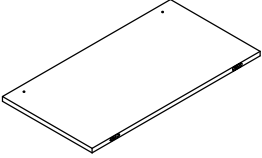
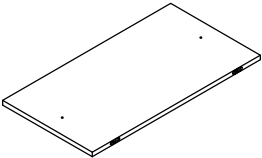
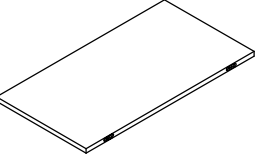
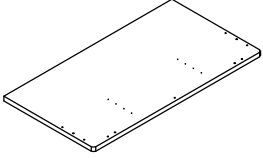
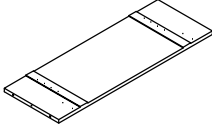
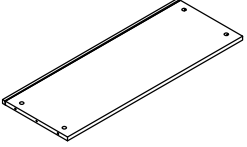
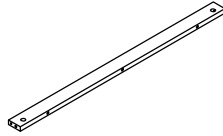
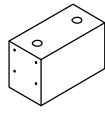
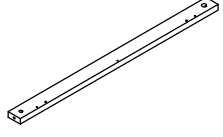
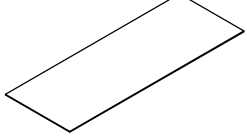
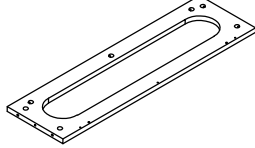
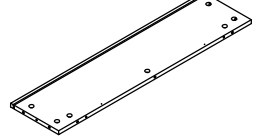
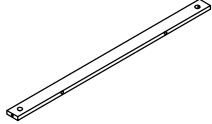
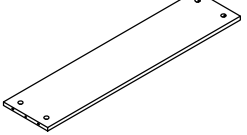
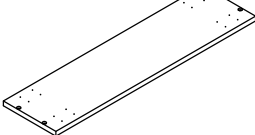
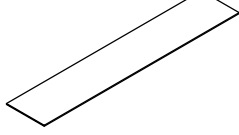



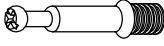



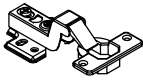

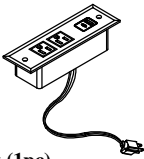

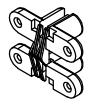
PART LIST

1  Top panel - 1pc	2  Up front panel - 1pc	3  Up back panel - 1pc	4  Up side panel - 2pcs
5  Middle frame - 1pc	10  Left side panel - 1pc	11  Middle panel - 1pc	12  Right side panel - 1pc
17  Bottom panel - 1pc	19  Rail - 1pc	20  Up left back panel - 1pc	21  Lower left back panel - 1pc
23  Door - 1pc	24  Adjustable shelf - 1pc	25  Left plate of the activity rack - 1pc	26  Right plate of the activity rack - 1pc
33  Lower back panel of the activity rack- 1pc	34  Left door of the activity rack - 1pc	35  Right door of the activity rack - 1pc	36  Drawer front panel - 1pc
37  Drawer left side panel - 1pc	38  Drawer right side panel - 1pc	39  Drawer back panel - 1pc	40  Drawer bottom panel - 1pc

PART LIST

<p>6</p>  <p>Top panel - 1pc</p>	<p>7</p>  <p>Top panel - 1pc</p>	<p>8</p>  <p>Top panel - 1pc</p>	<p>9</p>  <p>Top panel - 1pc</p>
<p>13</p>  <p>Middle panel - 1pc</p>	<p>14</p>  <p>Fixed panel - 1pc</p>	<p>15</p>  <p>Rail- 1pc</p>	<p>16</p>  <p>Little piece of wood - 2pcs</p>
<p>18</p>  <p>Establish a rule - 1pc</p>	<p>22</p>  <p>Right back panel - 1pc</p>	<p>27</p>  <p>Front panel of the activity rack - 1pc</p>	<p>28</p>  <p>Fixed panel of the activity rack - 1pc</p>
<p>29</p>  <p>Rail of the activity rack - 1pc</p>	<p>30</p>  <p>Fixed panel of the activity rack- 1pc</p>	<p>31</p>  <p>Bottom panel of the activity rack - 1pc</p>	<p>32</p>  <p>Up back panel of the activity rack- 1pc</p>

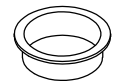
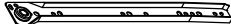
HARDWARE LIST

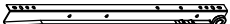
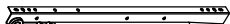
<p>A</p>  <p style="text-align: center;">Ø6.5*35mm</p> <p>Minifix (72+3pcs)</p>	<p>B</p>  <p style="text-align: center;">Ø15*9mm</p> <p>Minifix cap (72+3pcs)</p>	<p>C</p>  <p style="text-align: center;">Ø6*30mm</p> <p>Wood dowel (54+3pcs)</p>	<p>D</p>  <p style="text-align: center;">Ø4*35mm</p> <p>Wood screw (25+2pcs)</p>
<p>E</p>  <p style="text-align: center;">M6*45mm</p> <p>Blot (11+1pcs)</p>	<p>F</p>  <p>Soft close hinges (6pcs)</p>	<p>G</p>  <p style="text-align: center;">Ø4*12mm</p> <p>Wood screw (48+3pcs)</p>	<p>H</p>  <p>Insert Row (1pc)</p>
<p>I</p>  <p>Locating piece (2pcs)</p>	<p>J</p>  <p style="text-align: center;">Ø3*12mm</p> <p>Wood screw (10+1pcs)</p>	<p>K</p>  <p>Hinges (6pcs)</p>	<p>L</p>  <p style="text-align: center;">Ø4*19mm</p> <p>Wood screw (24+2pcs)</p>
<p>M</p>  <p style="text-align: center;">Ø10*10mm</p> <p>Handle (11+1pcs)</p>	<p>N</p>  <p>Shelf support (4+1pcs)</p>	<p>P</p>  <p style="text-align: center;">Ø5*16mm</p> <p>Wood screw (16+1pcs)</p>	<p>Q</p>  <p>Allen wrench (1pc)</p>
<p>R</p>  <p>Caster wheels (5pcs)</p>	<p>S</p>  <p>Caster wheels (4pcs)</p>	<p>T</p>  <p style="text-align: center;">Ø4*14mm</p> <p>Wood screw (36+2pcs)</p>	<p>U</p>  <p>Outlet cover (1pc)</p>
<p>CL</p>  <p style="text-align: center;">350mm</p> <p>Slide rail (1pc)</p>	<p>CR</p>  <p style="text-align: center;">350mm</p> <p>Slide rail (1pc)</p>	<p>DL</p>  <p style="text-align: center;">350mm</p> <p>Slide rail (1pc)</p>	<p>DR</p>  <p style="text-align: center;">350mm</p> <p>Slide rail (1pc)</p>

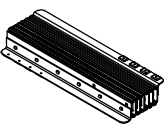

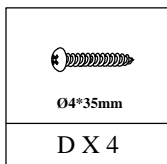
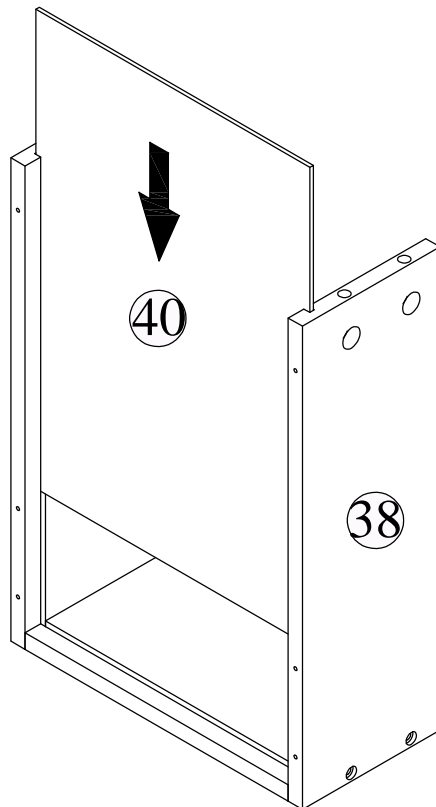
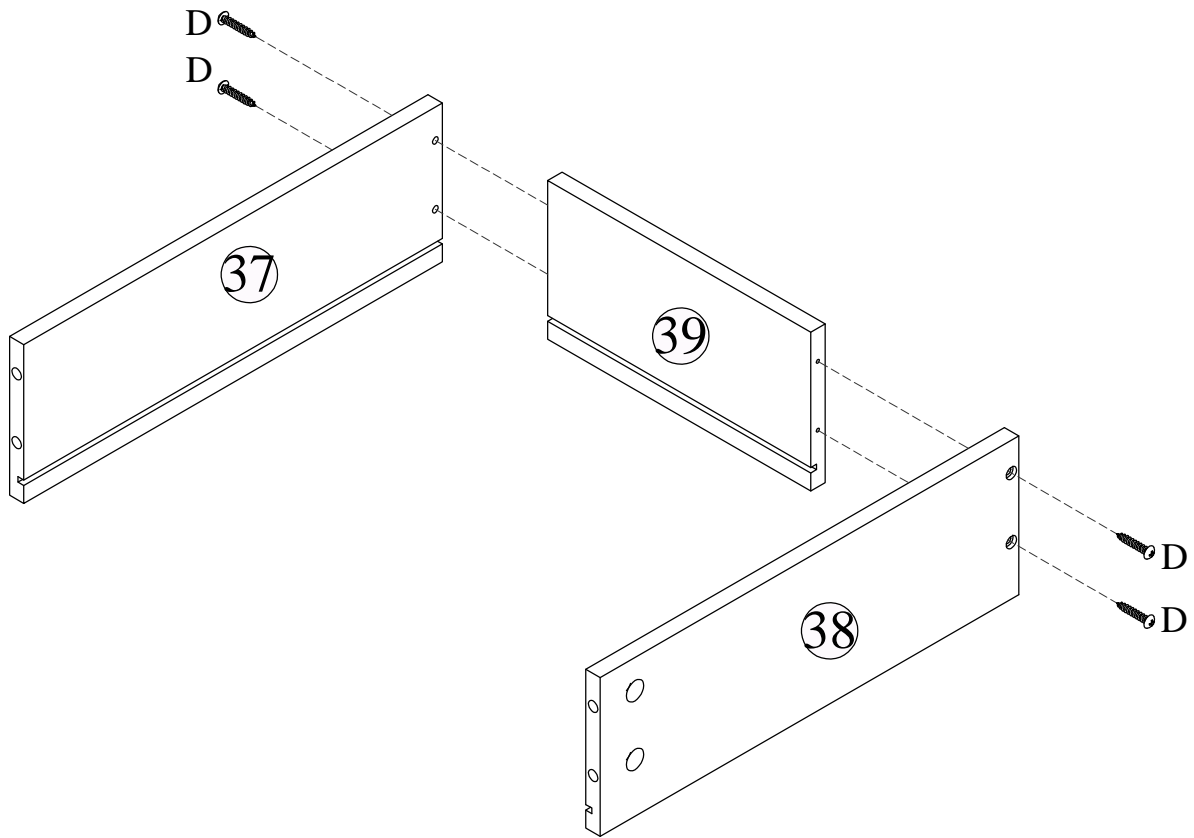

O	
Slide rail (2pcs)	

Step 1

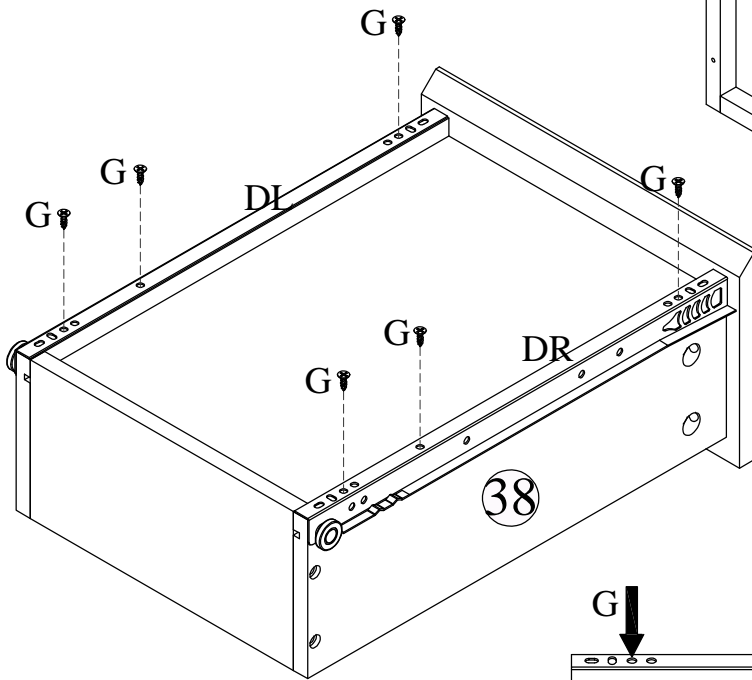
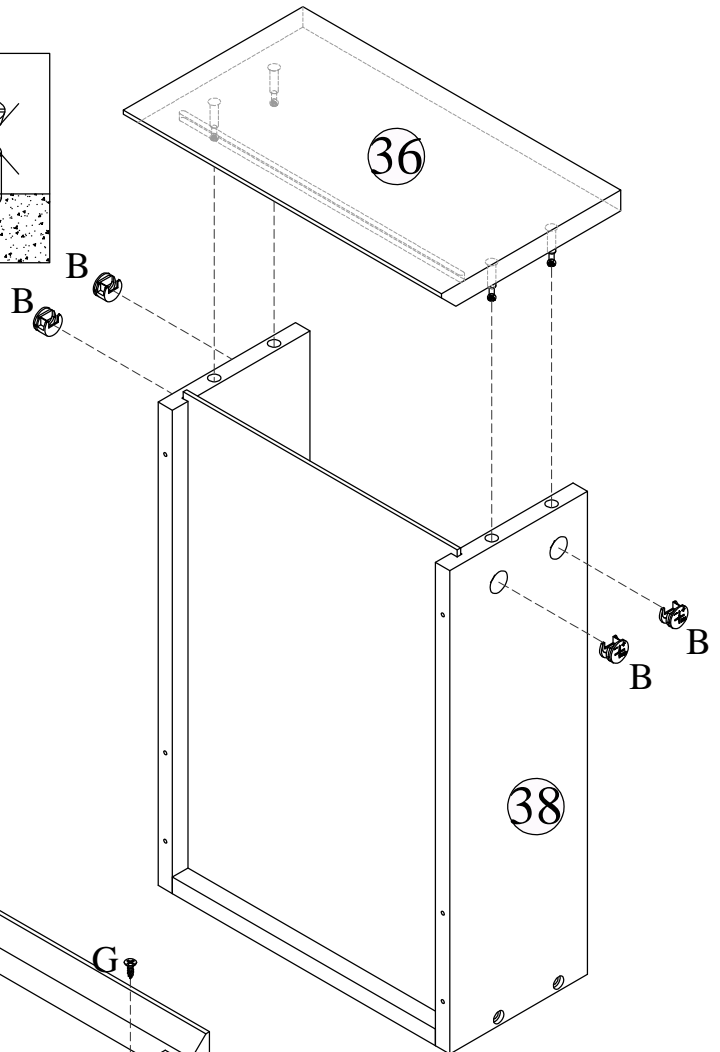
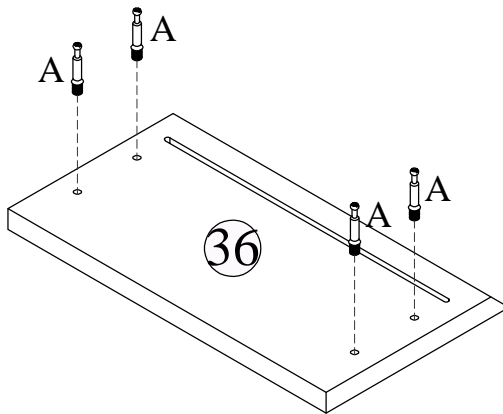
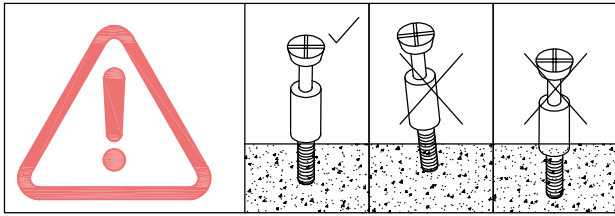

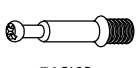
Step 2



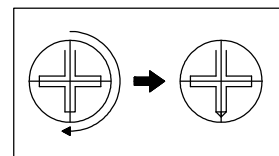

				
Ø6.5*35mm	Ø15*9mm	Ø4*12mm	350mm	350mm
A X 4	B X 4	G X 6	DL X 1	DR X 1

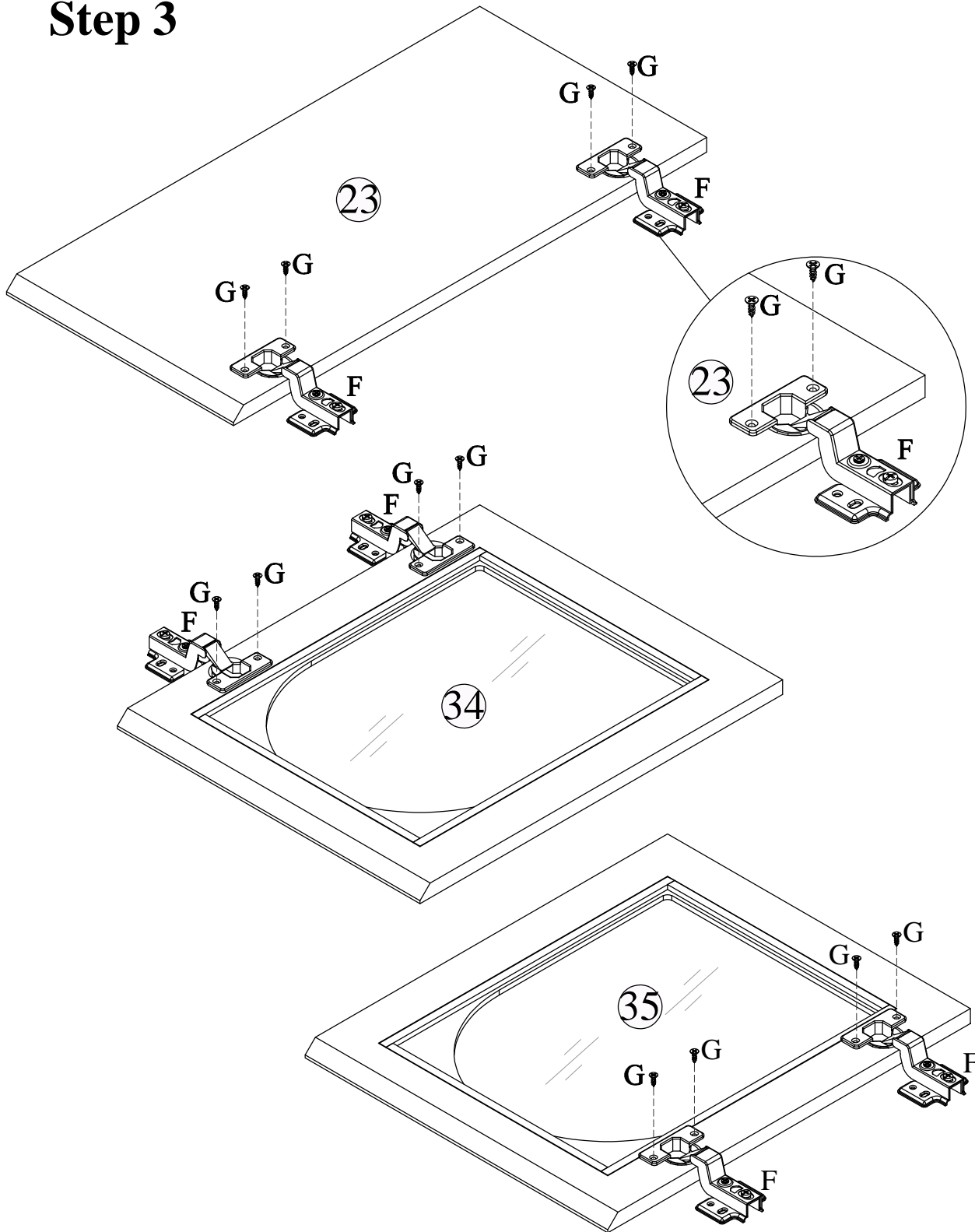

Lock Minifix cap clockwise

Step 3

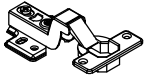

	
FX 6	GX 12

Step 4

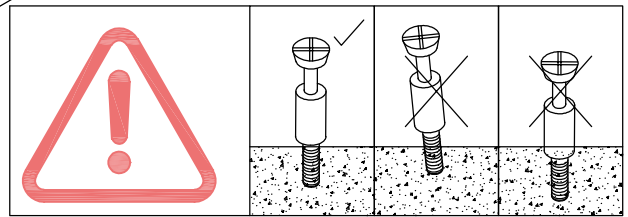
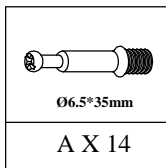
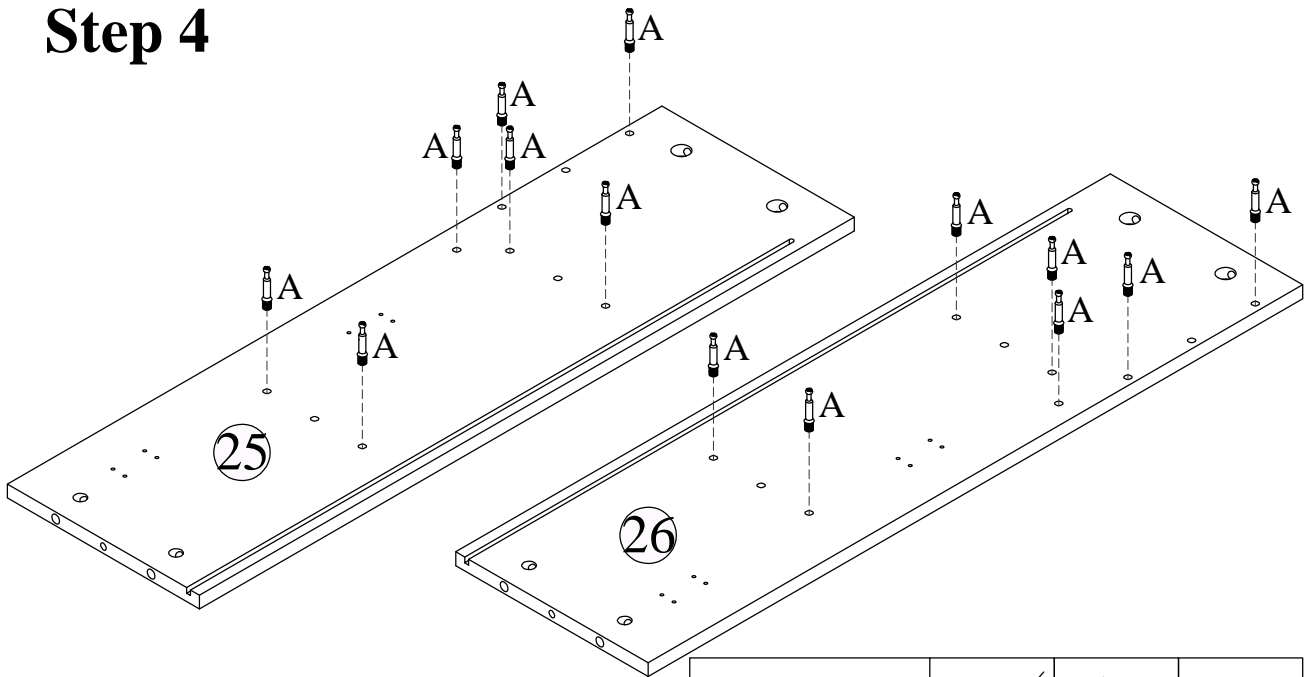

Step 5

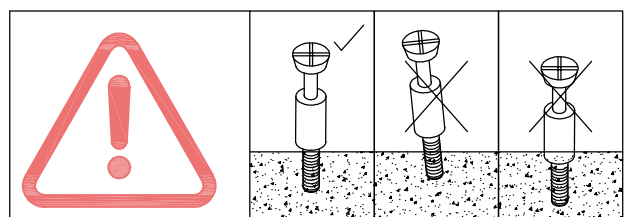
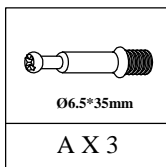
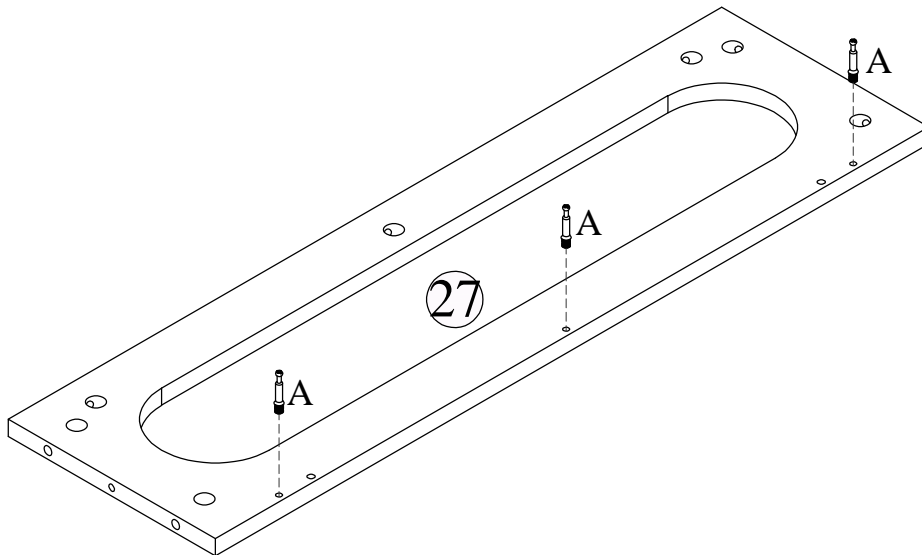

Step 6

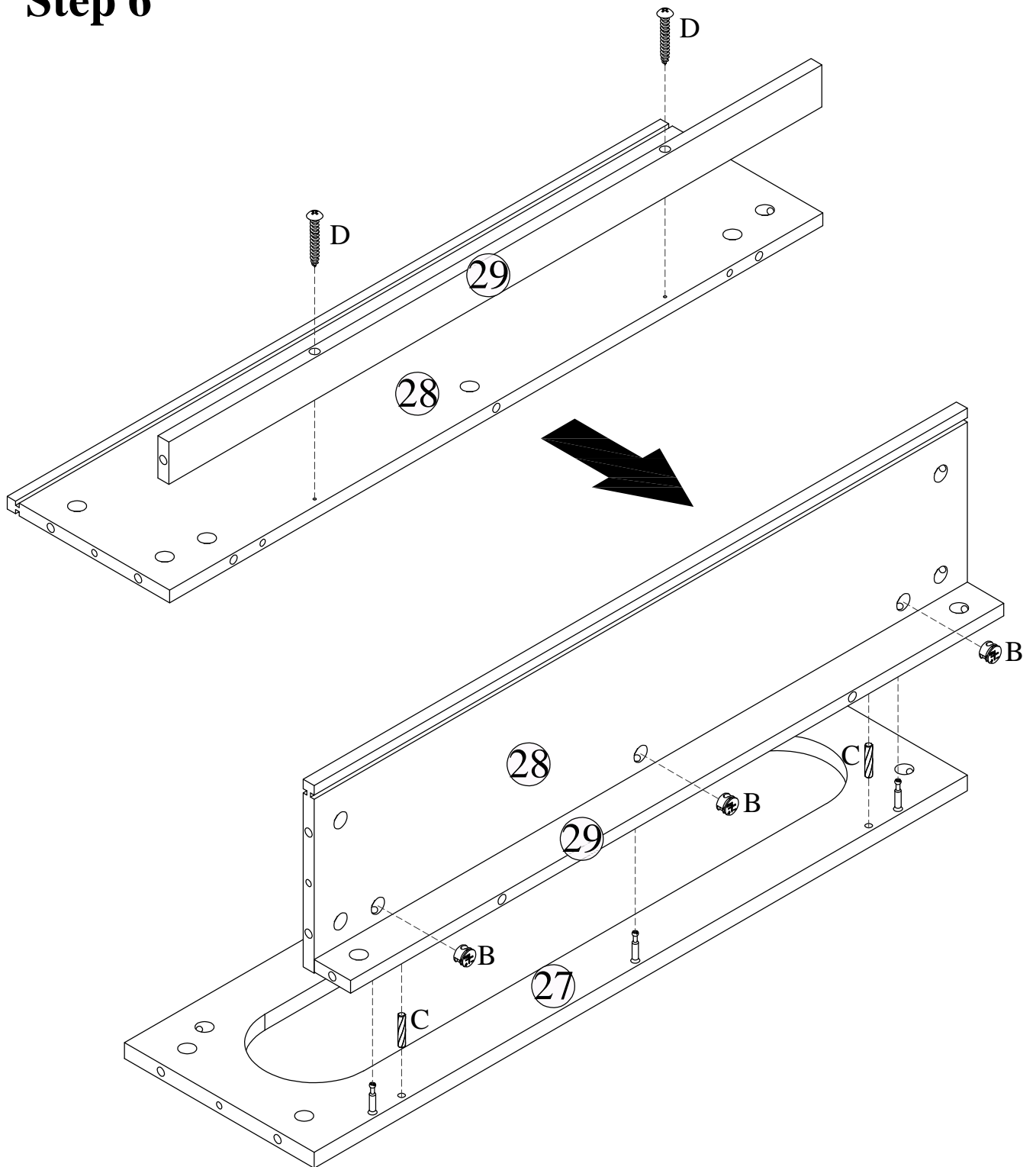

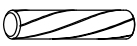
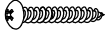

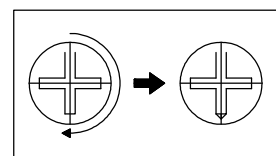
		
Ø15*9mm	Ø6*30mm	Ø4*35mm
B X 3	C X 2	D X 2

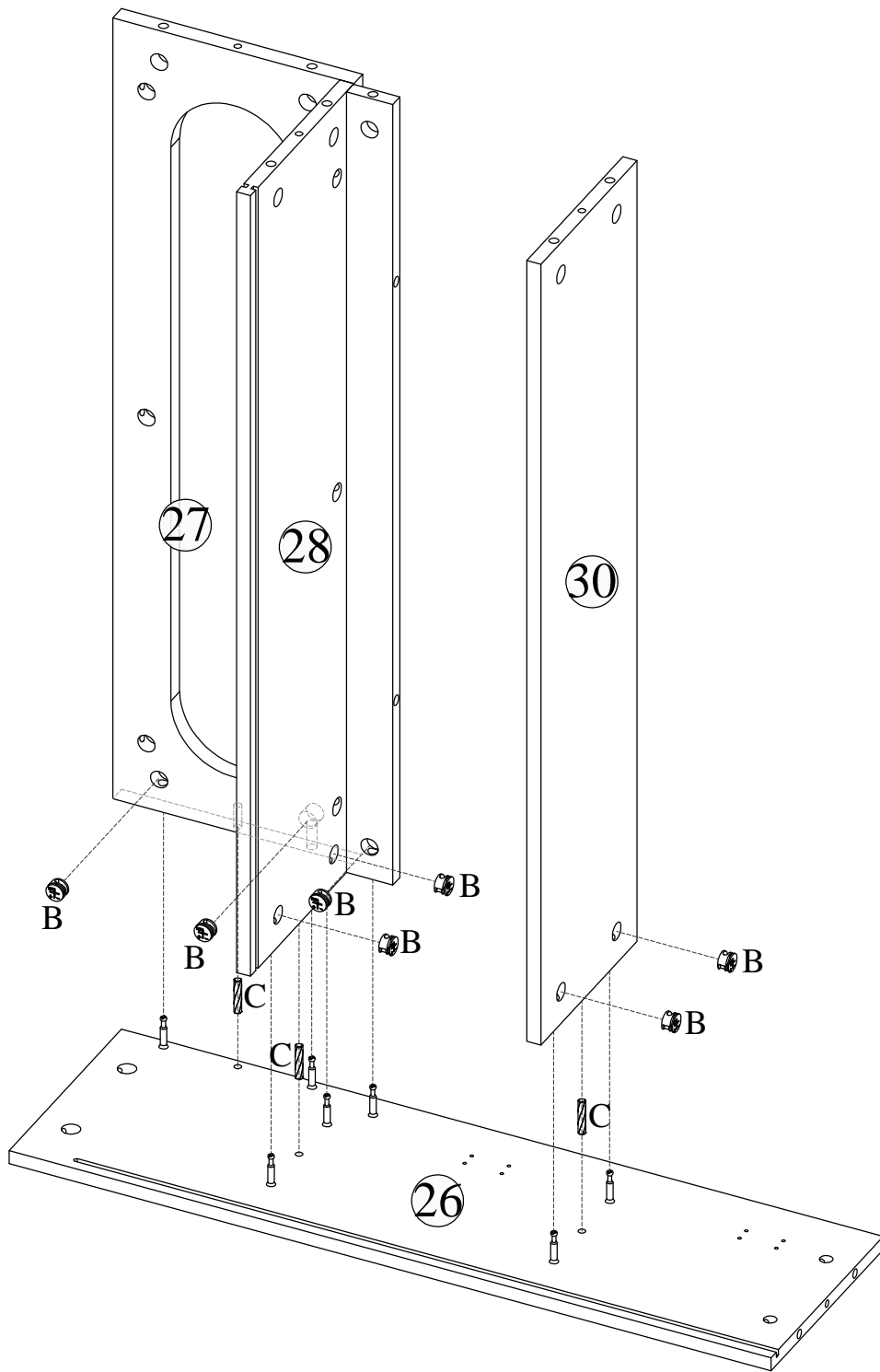

Lock Minifix cap clockwise

Step 7



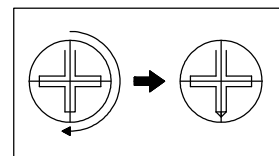

	
Ø15*9mm	Ø6*30mm
B X 7	C X 3

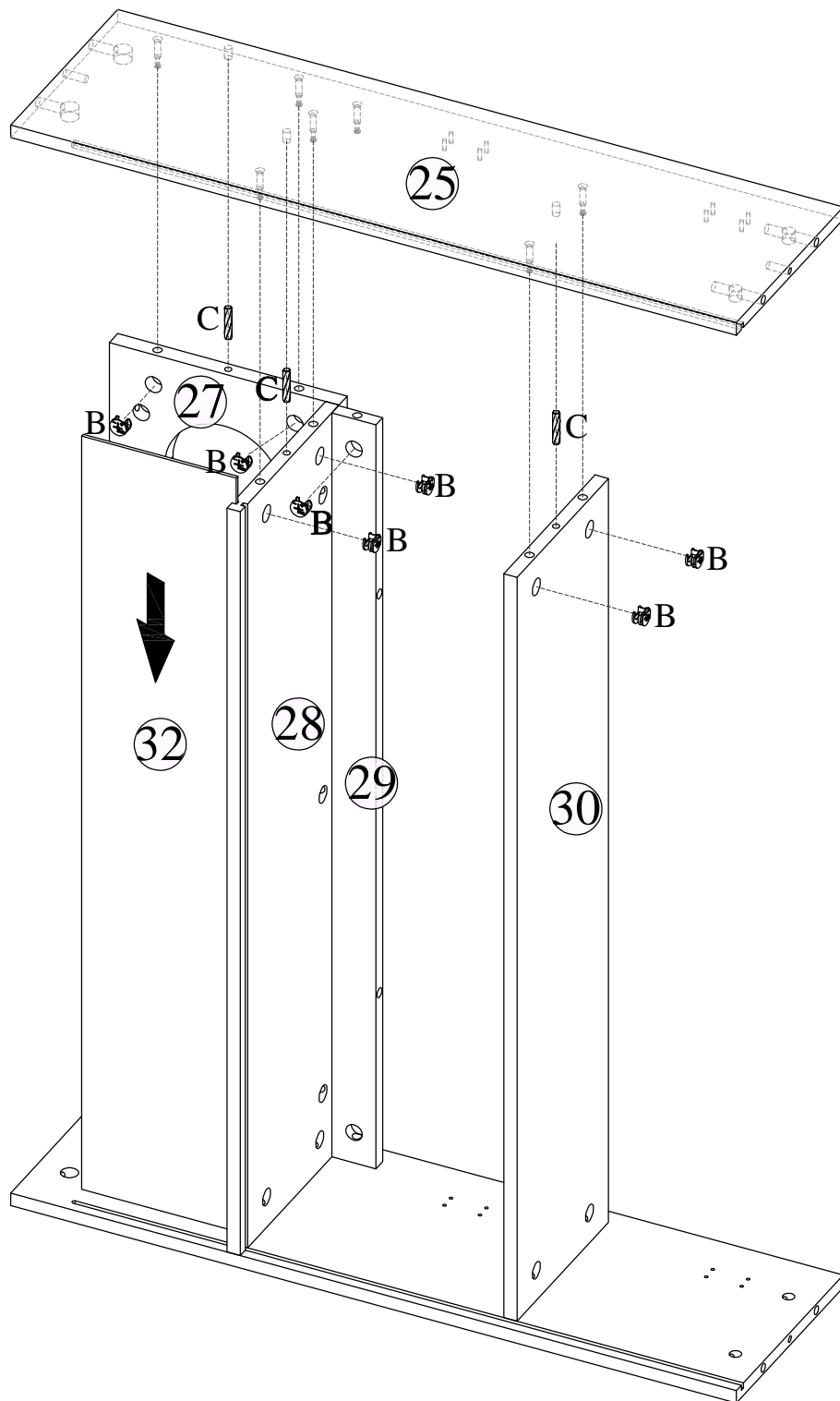

Lock Minifix cap clockwise

Step 8

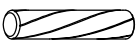

	
Ø15*9mm	Ø6*30mm
B X 7	C X 3

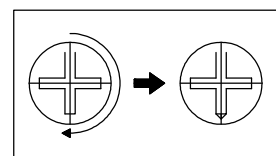



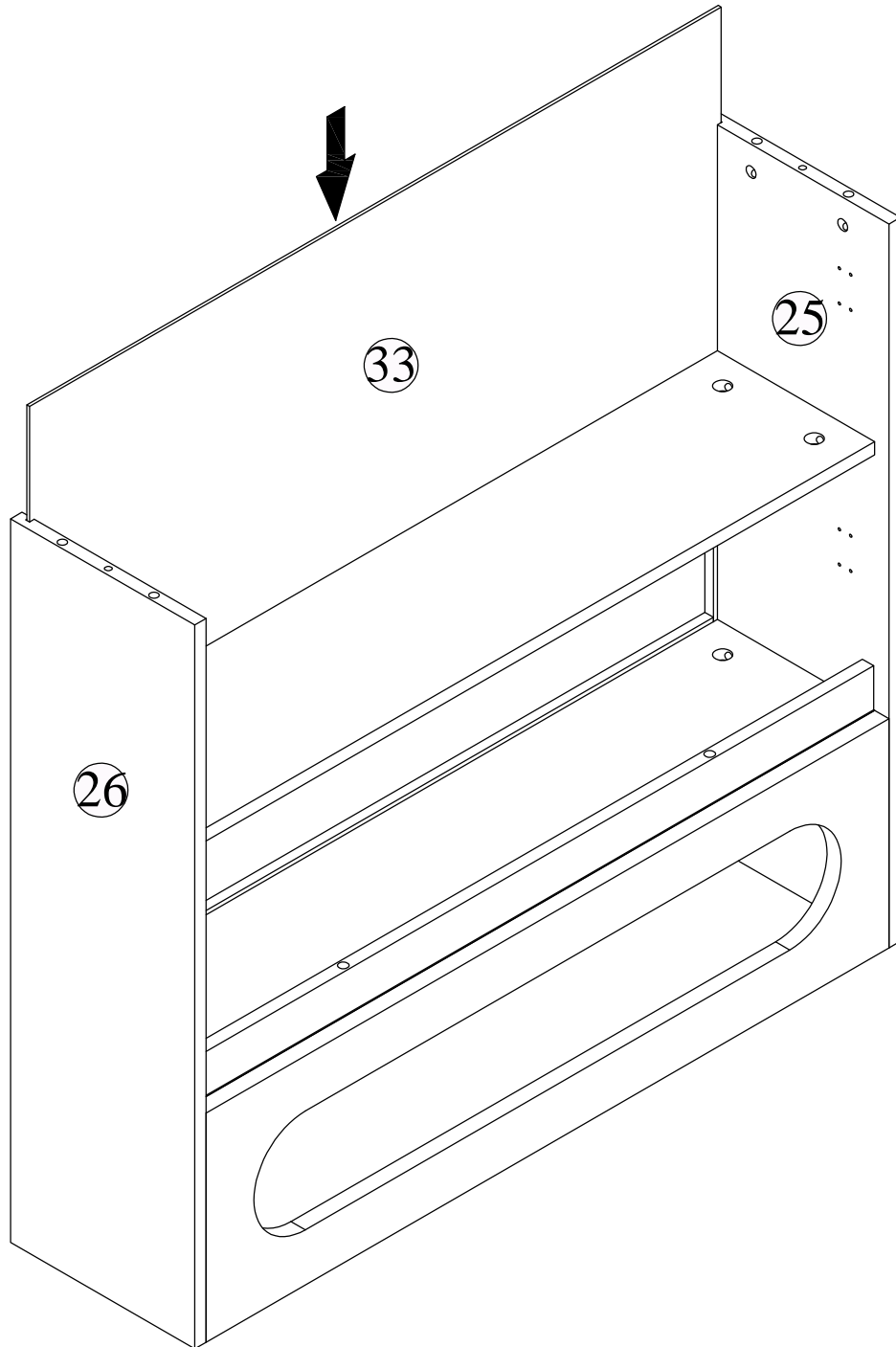

Lock Minifix cap clockwise

Step 9

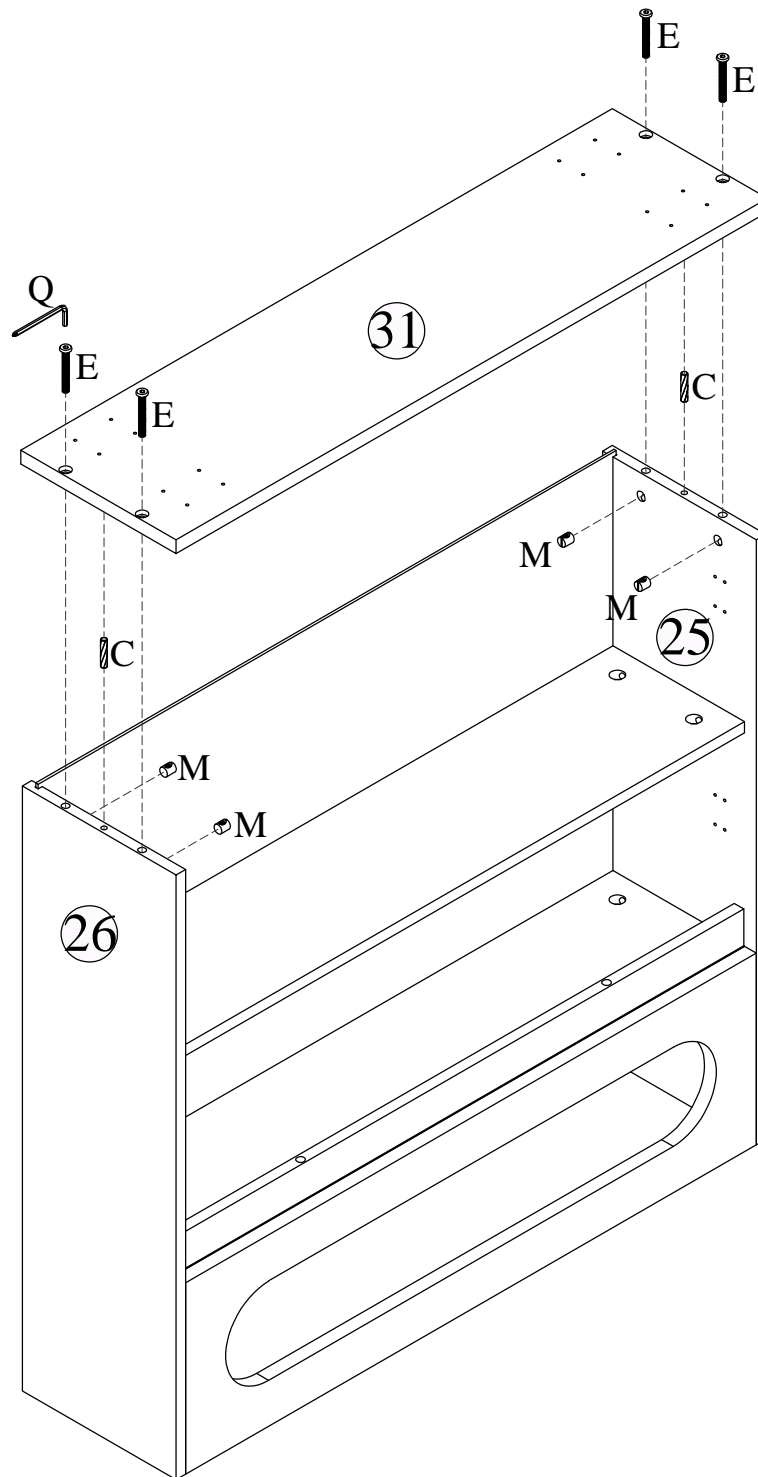

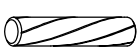



Step 10

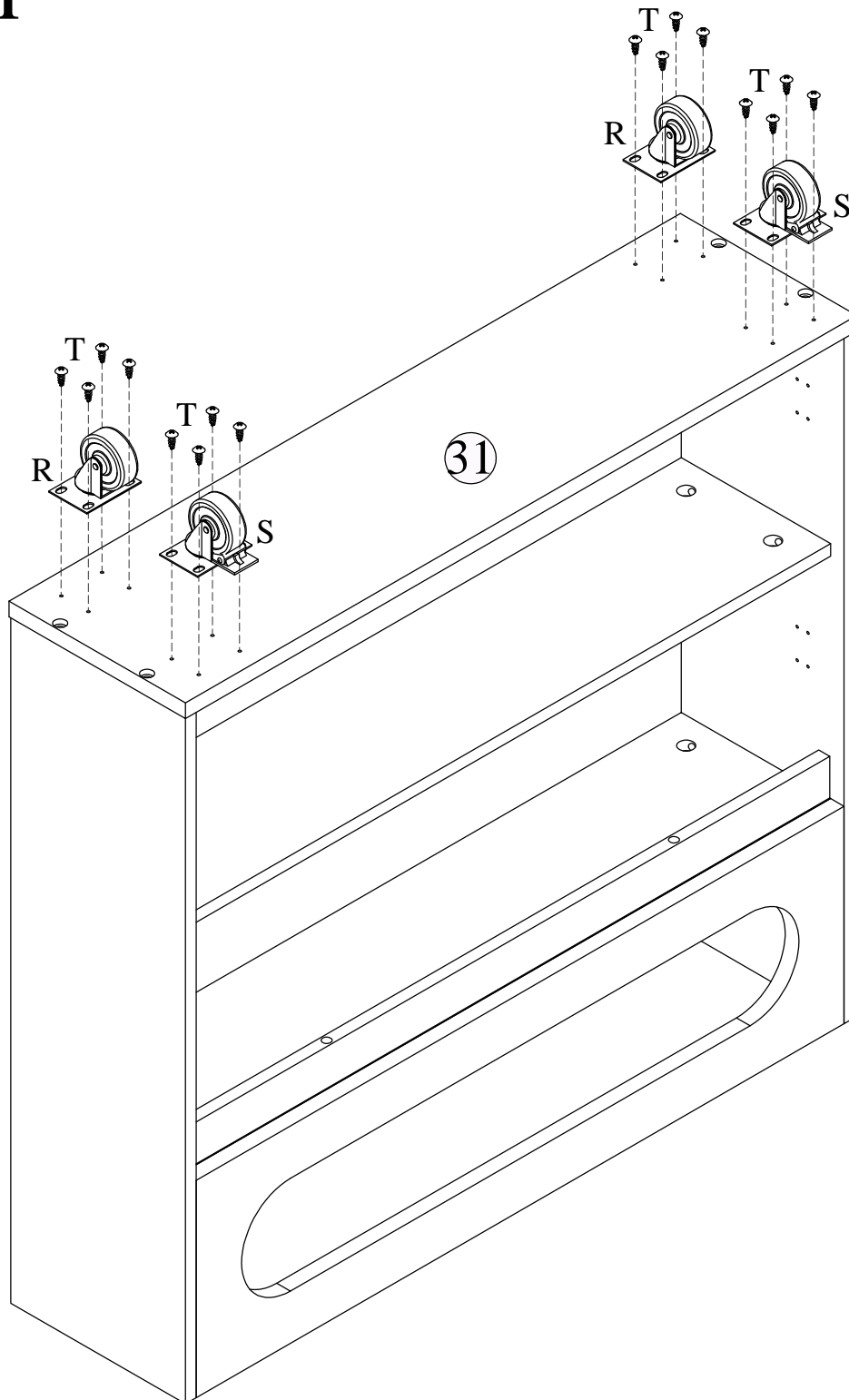

			
Ø6*30mm	M6*45mm	Ø10*10mm	
C X 2	E X 4	M X 4	Q X 1



Step 11

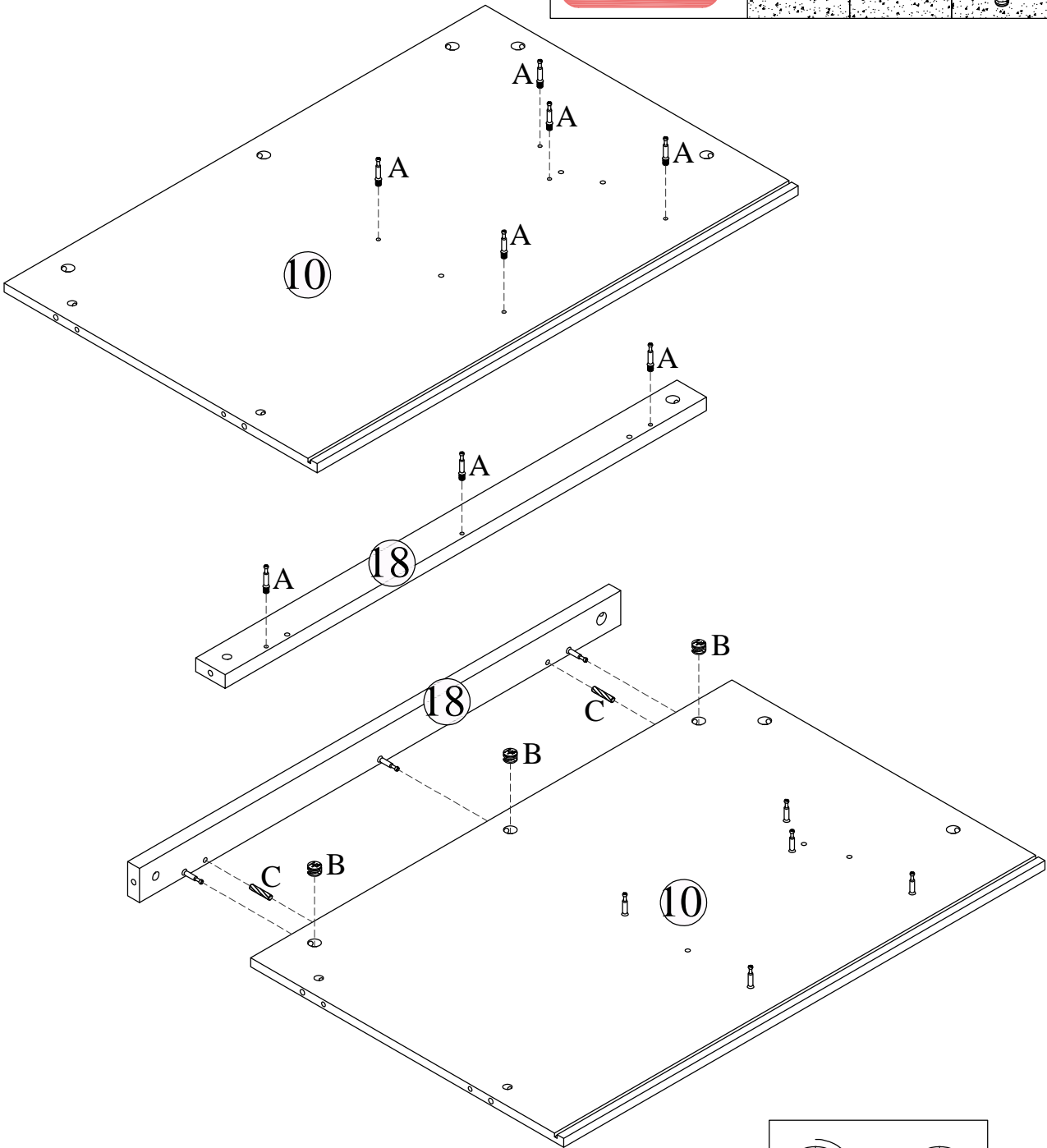
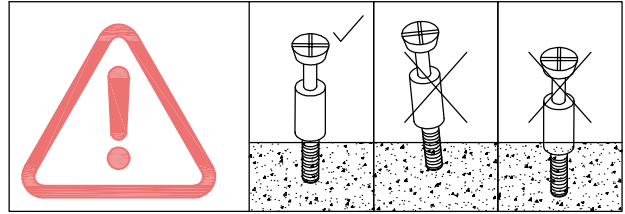

		
R X 2	S X 2	T X 16 Ø4*14mm

Step 12

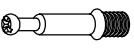

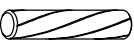
		
Ø6.5*35mm	Ø15*9mm	Ø6*30mm
A X 8	B X 3	C X 2

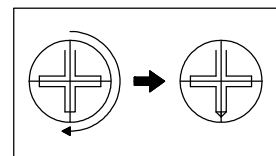

Lock Minifix cap clockwise

Step 13

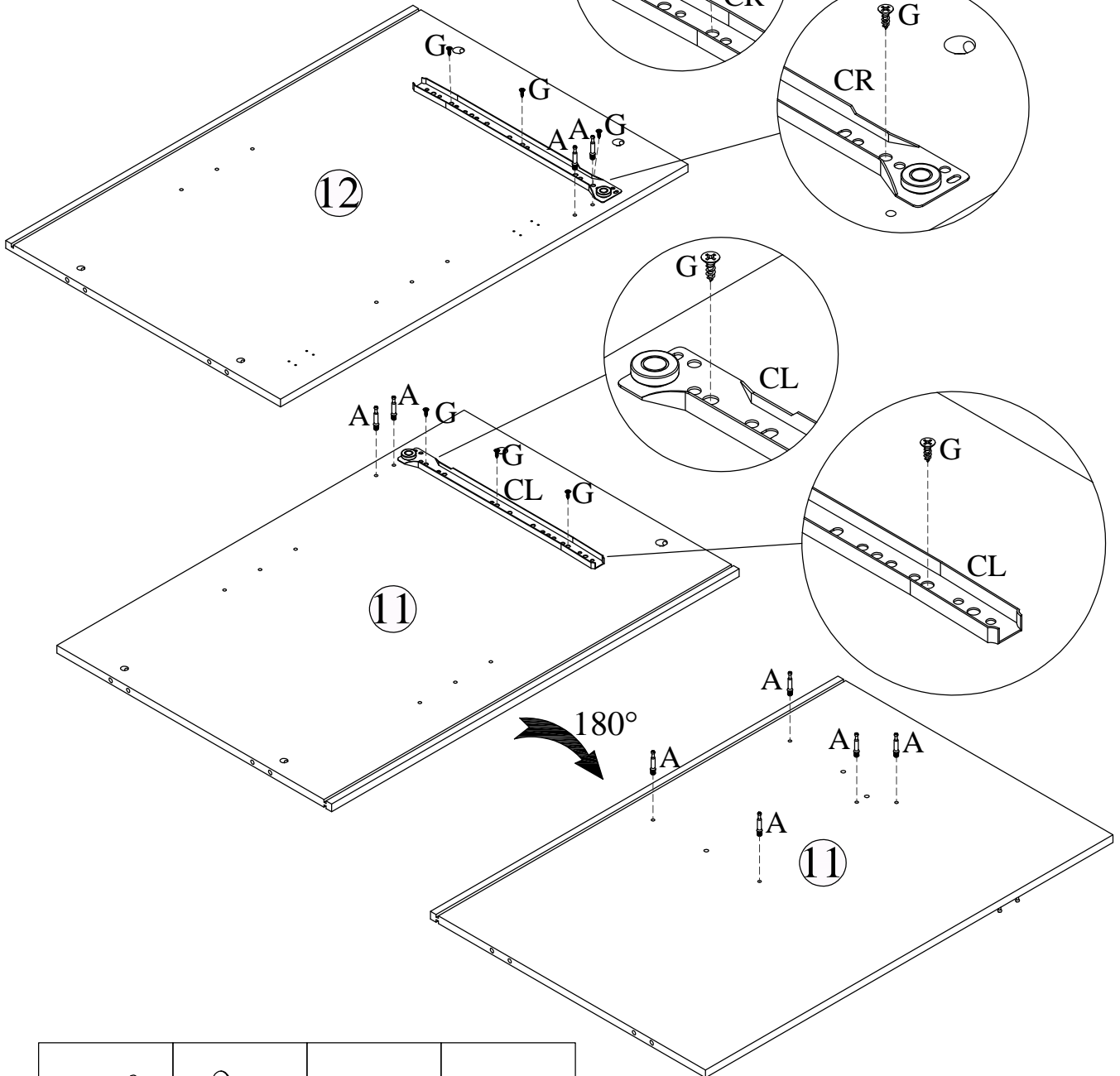
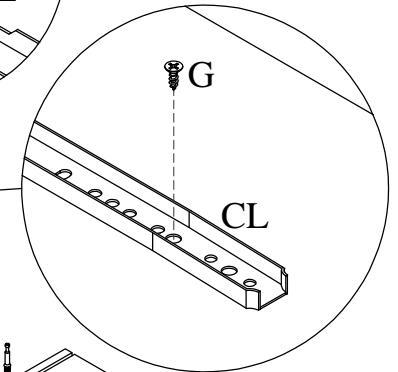
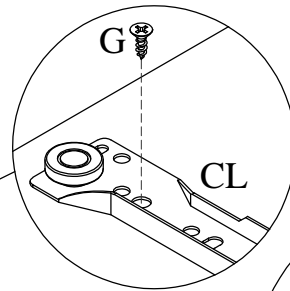
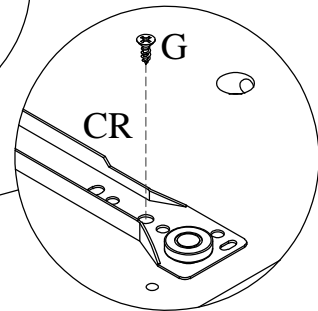
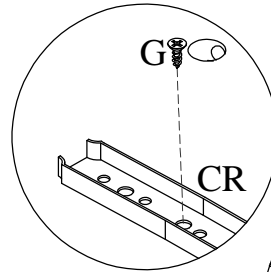
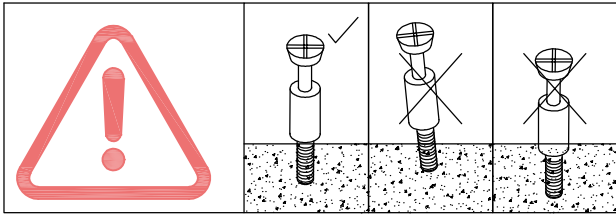
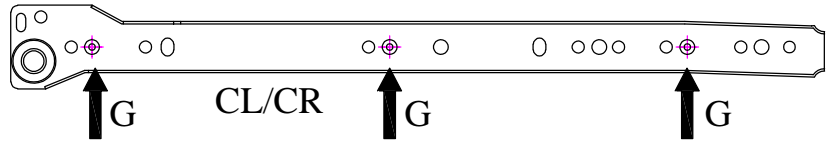

06.5*35mm	04*12mm	350mm	350mm
A X 9	G X 6	CL X 1	CR X 1

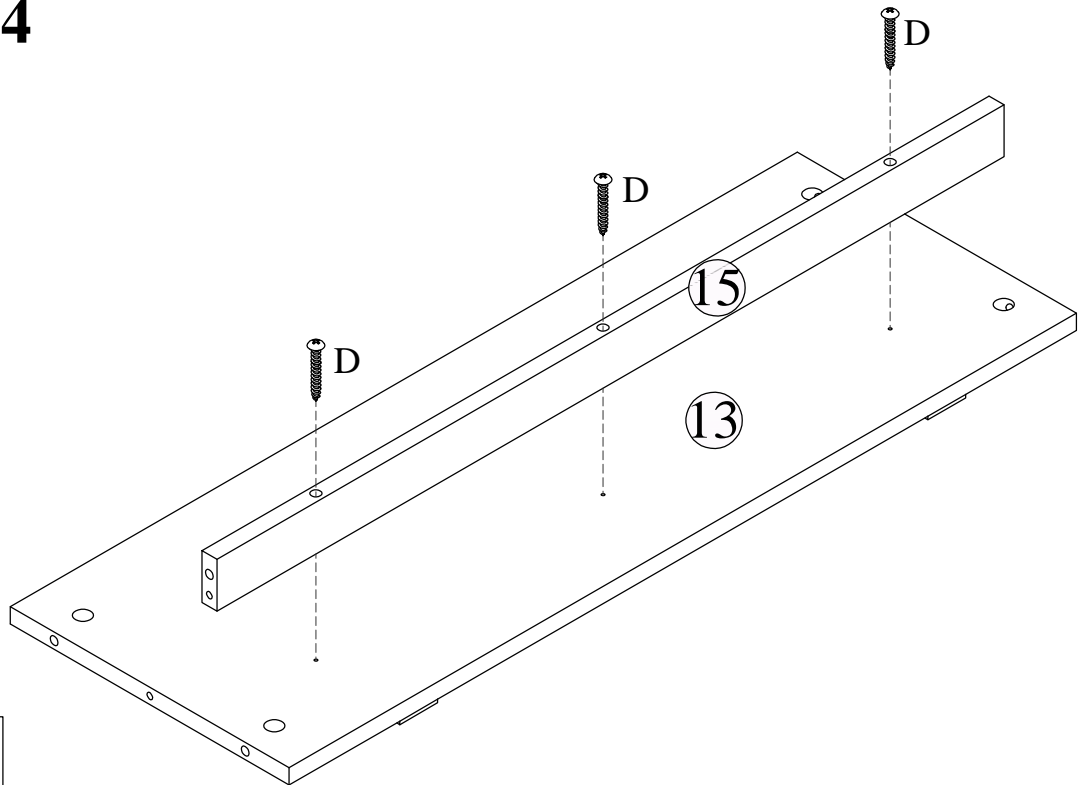

Step 14

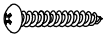

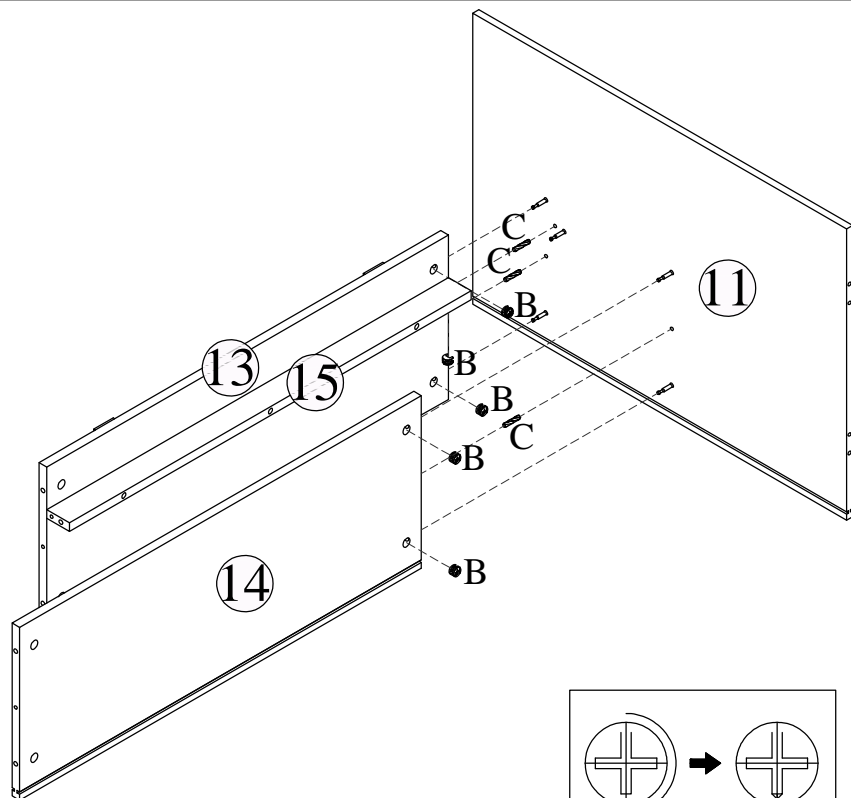

Ø4*35mm
D X 3

Step 15



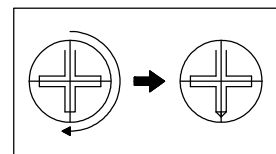

	
Ø15*9mm	Ø6*30mm
B X 5	C X 3

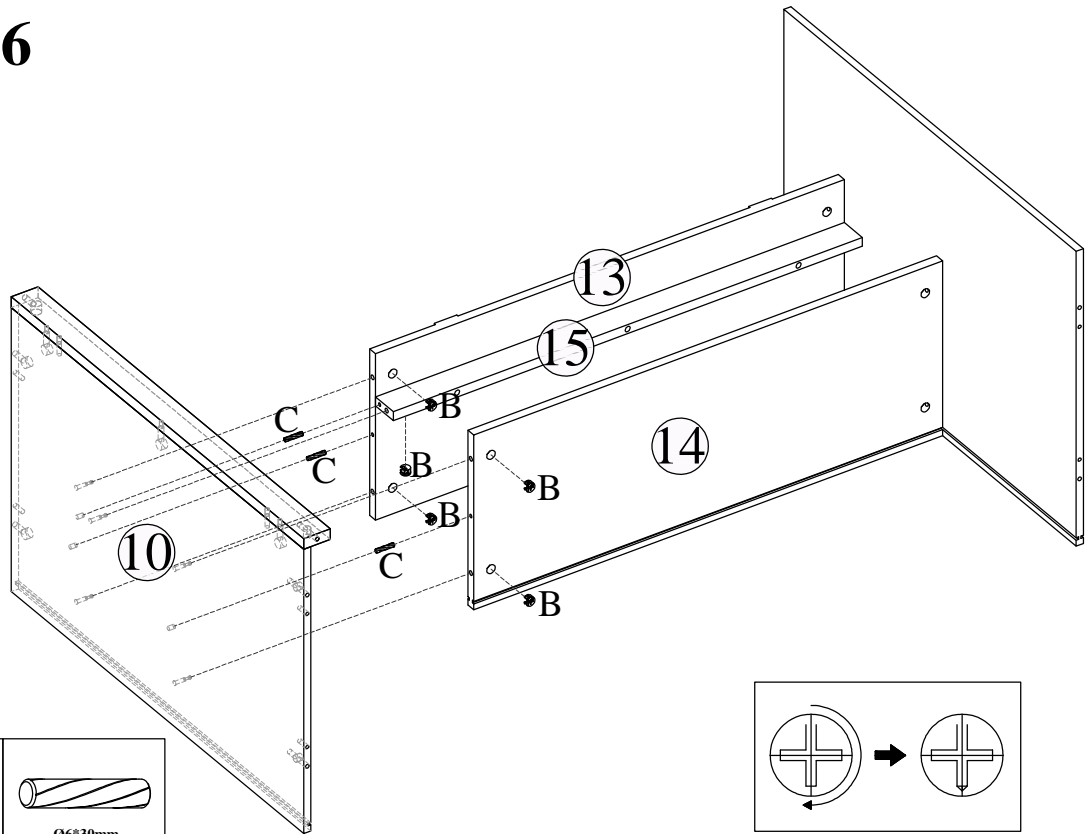

Lock Minifix cap clockwise

Step 16



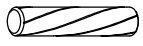

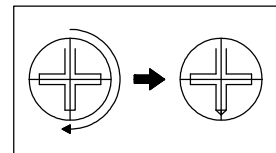
	
Ø15*9mm	Ø6*30mm
B X 5	C X 3

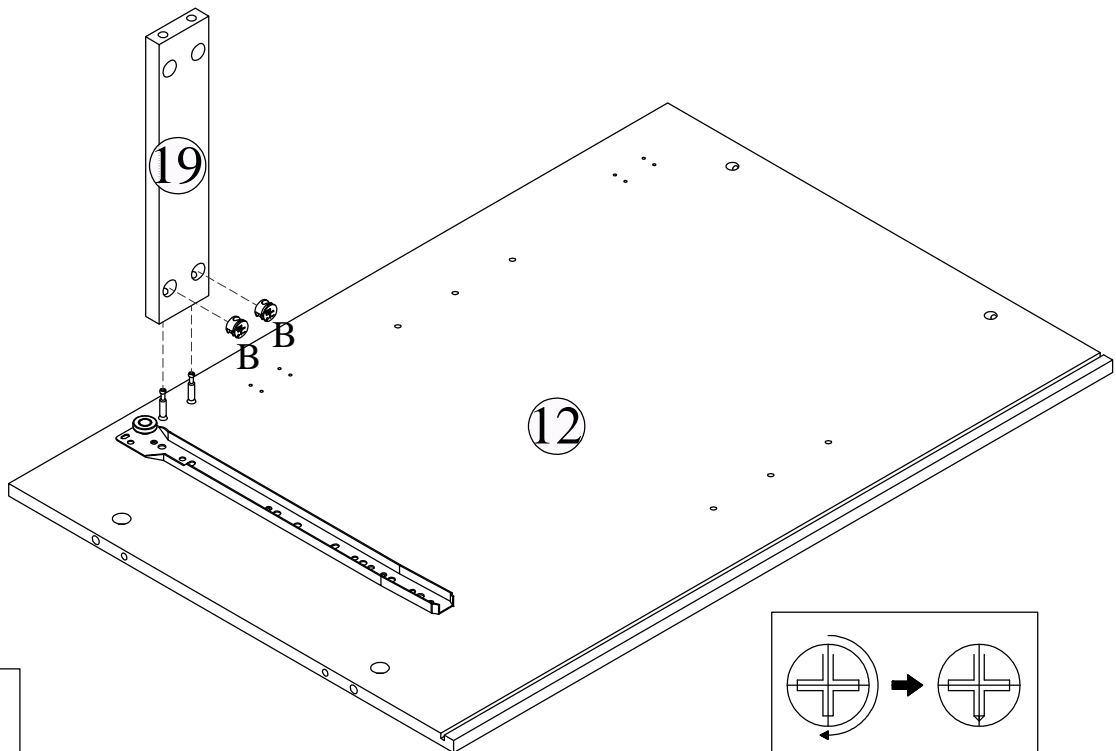

Lock Minifix cap clockwise

Step 17



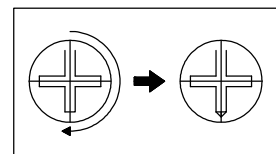

Ø15*9mm
B X 2

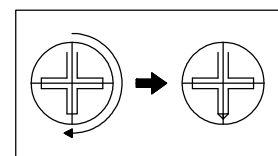
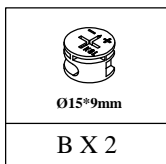
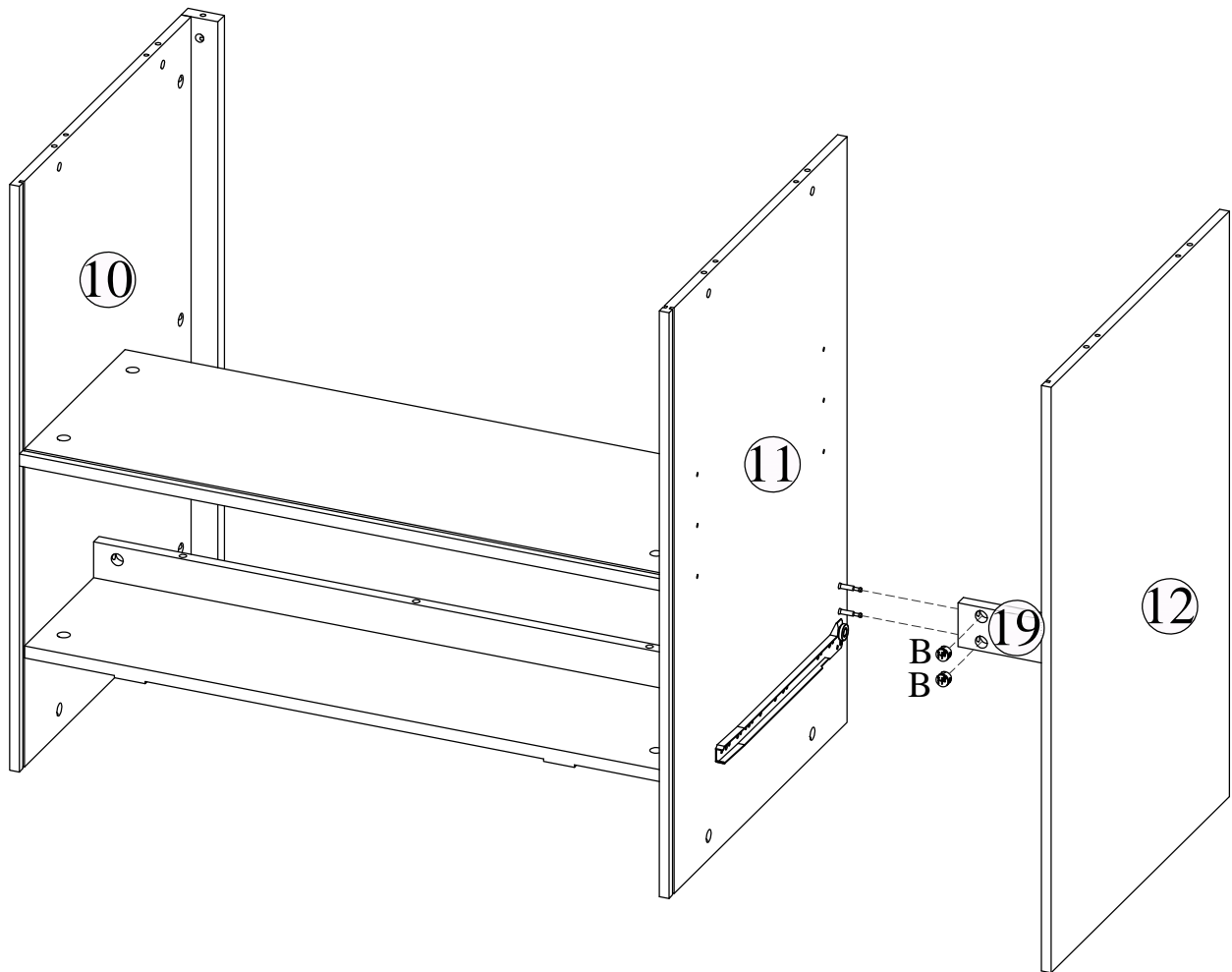

Lock Minifix cap clockwise

Step 18





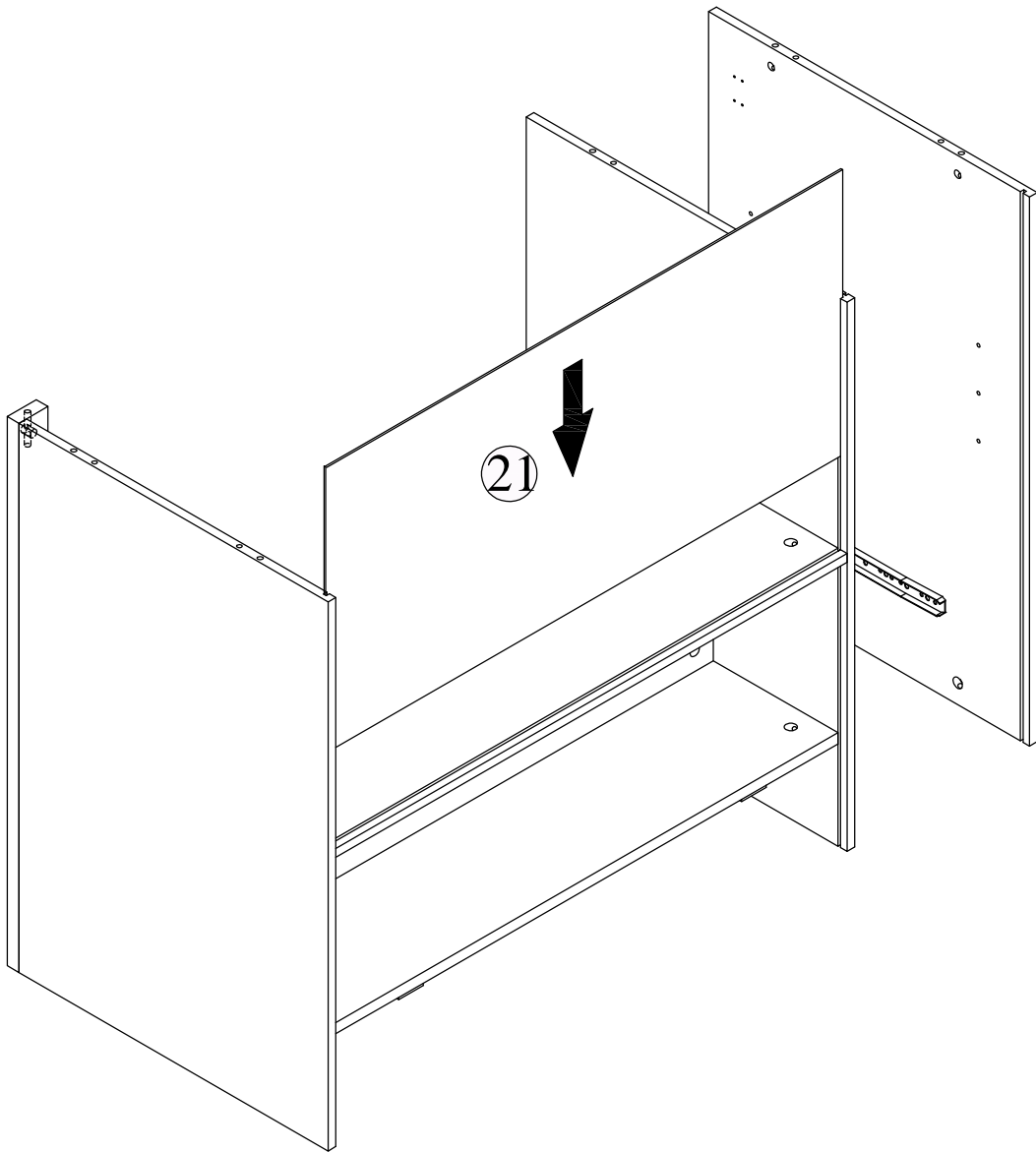

Lock Minifix cap clockwise

Step 19

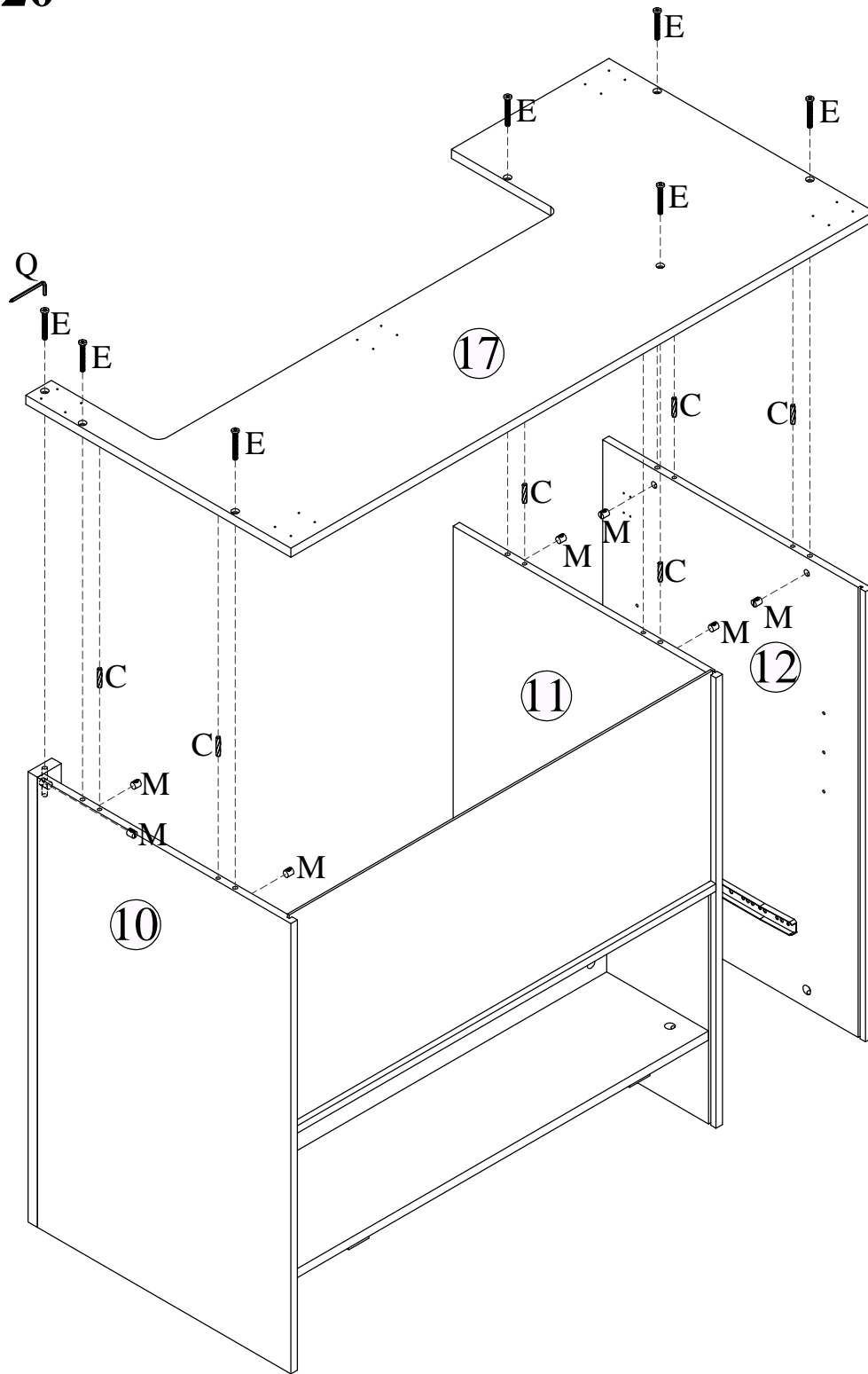





Step 20

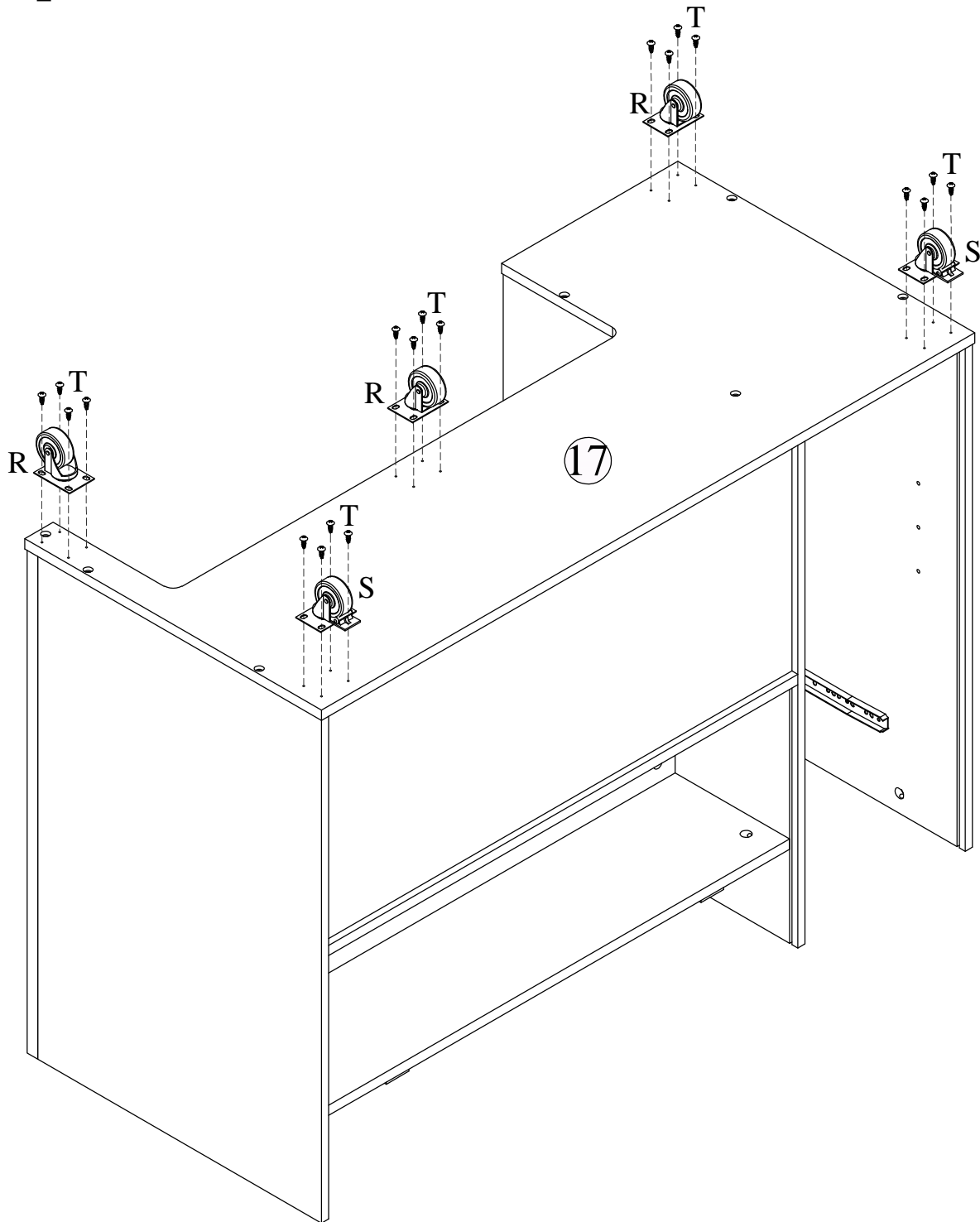

			
Ø6*30mm	M6*45mm	Ø10*10mm	
C X 6	E X 7	M X 7	Q X 1



Step 21



		 Ø4*14mm
R X 3	S X 2	T X 20

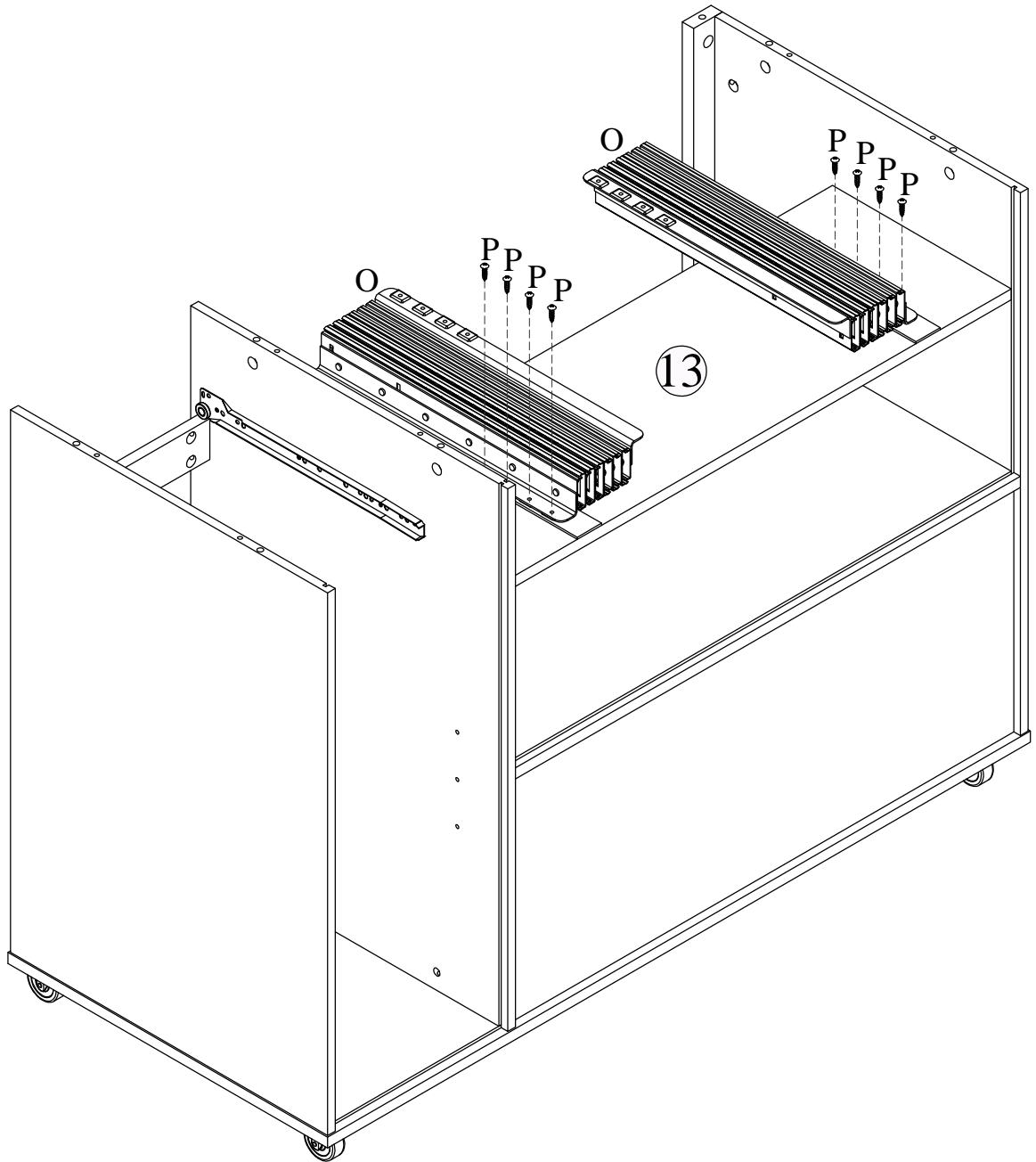

Step 22

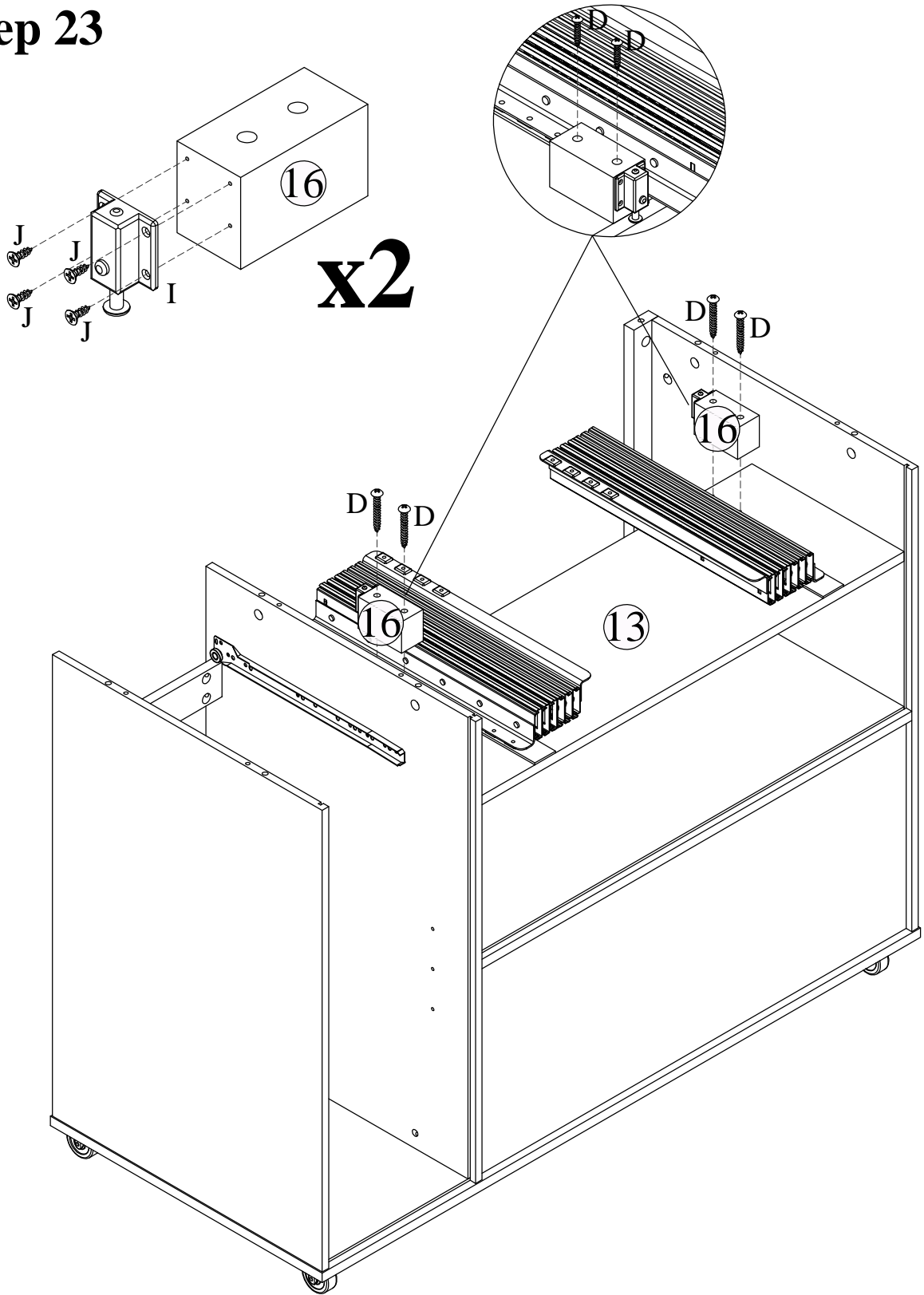

	
O X 2	P X 8 Ø5*16mm

Step 23



		
Ø4*35mm		Ø3*12mm
D X 4	I X 2	J X 8

Step 24

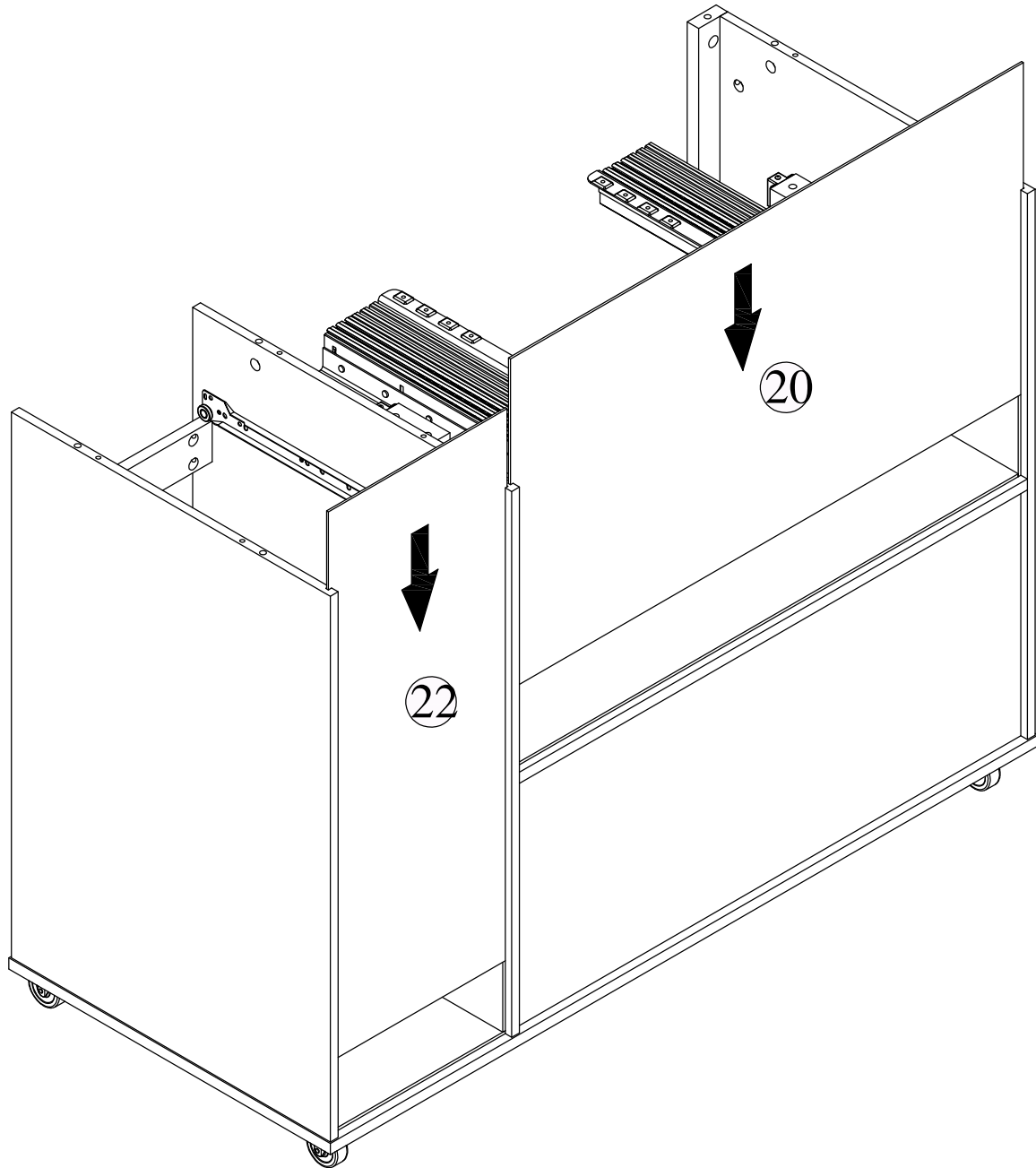

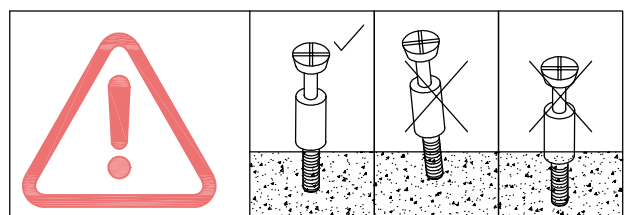
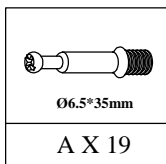
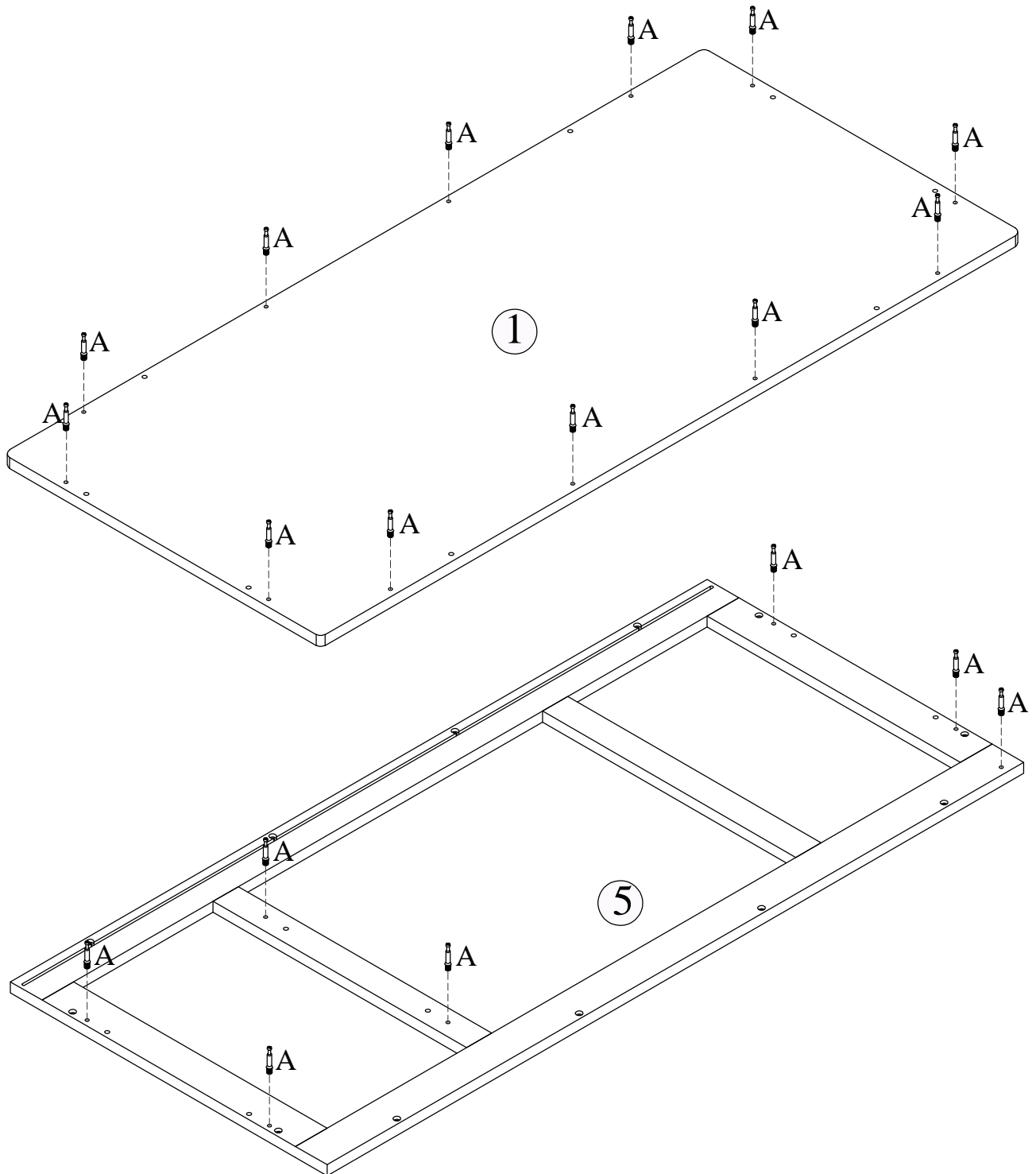

Step 25

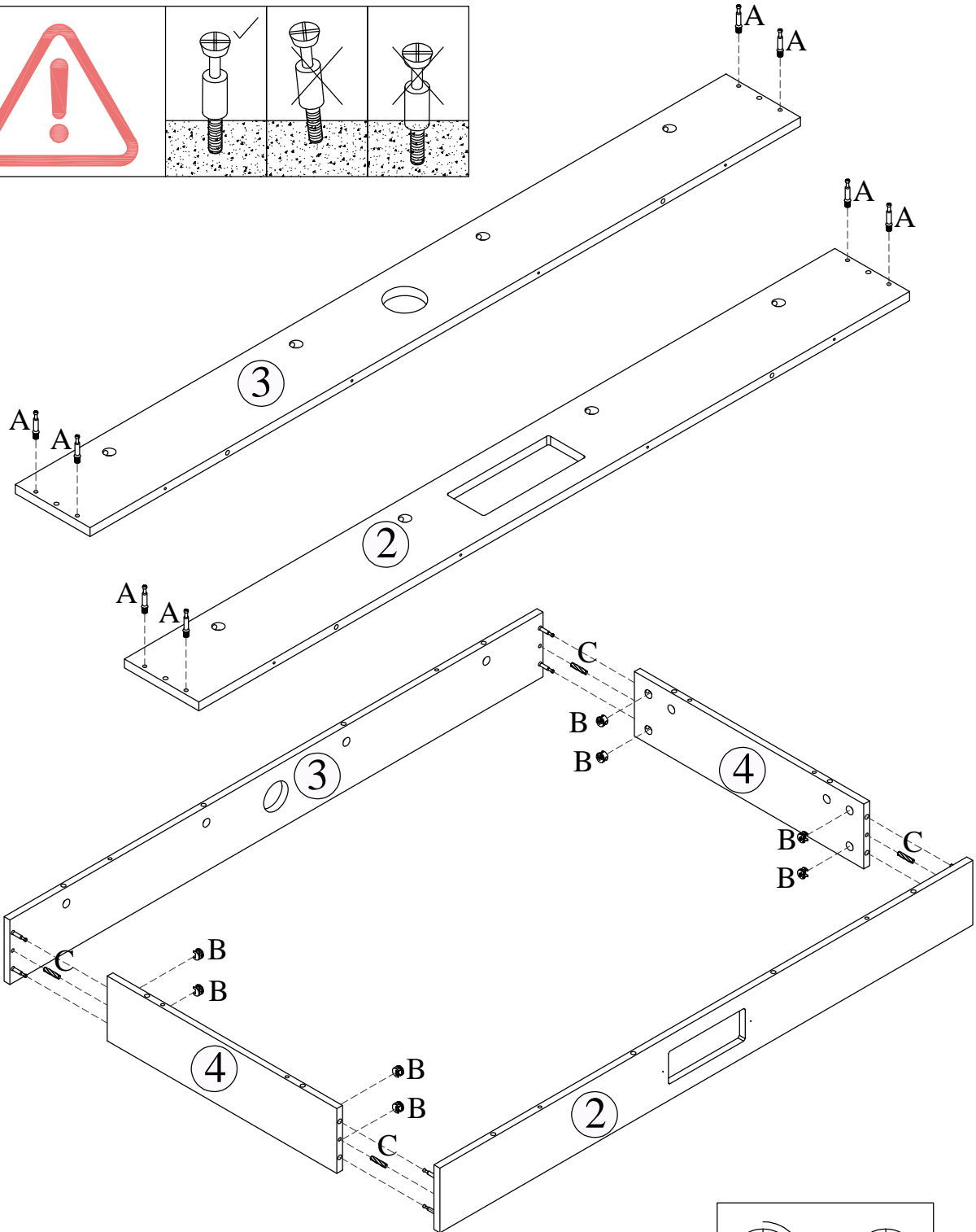
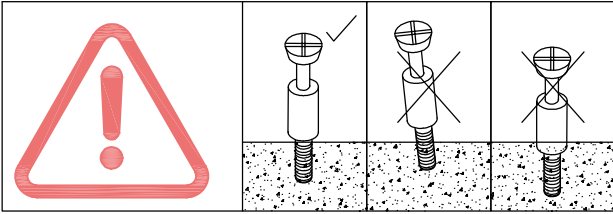

Step 26

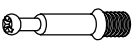

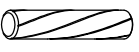

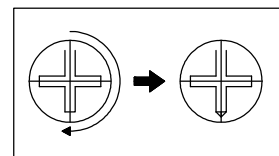
		
Ø6.5*35mm	Ø15*9mm	Ø6*30mm
A X 8	B X 8	C X 4

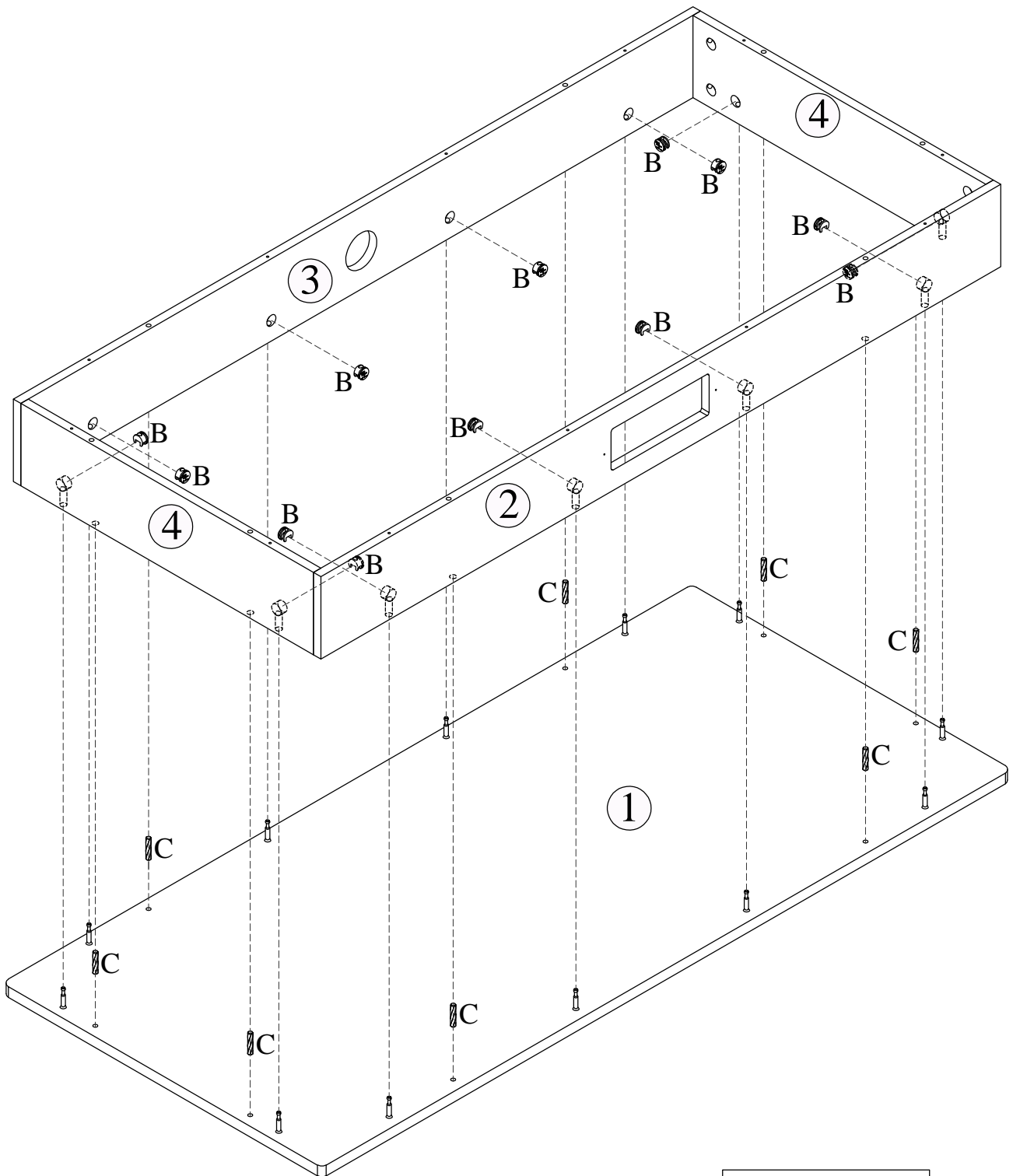

Lock Minifix cap clockwise

Step 27



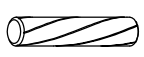

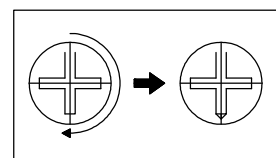
	
Ø15*9mm	Ø6*30mm
B X 12	C X 8



Lock Minifix cap clockwise

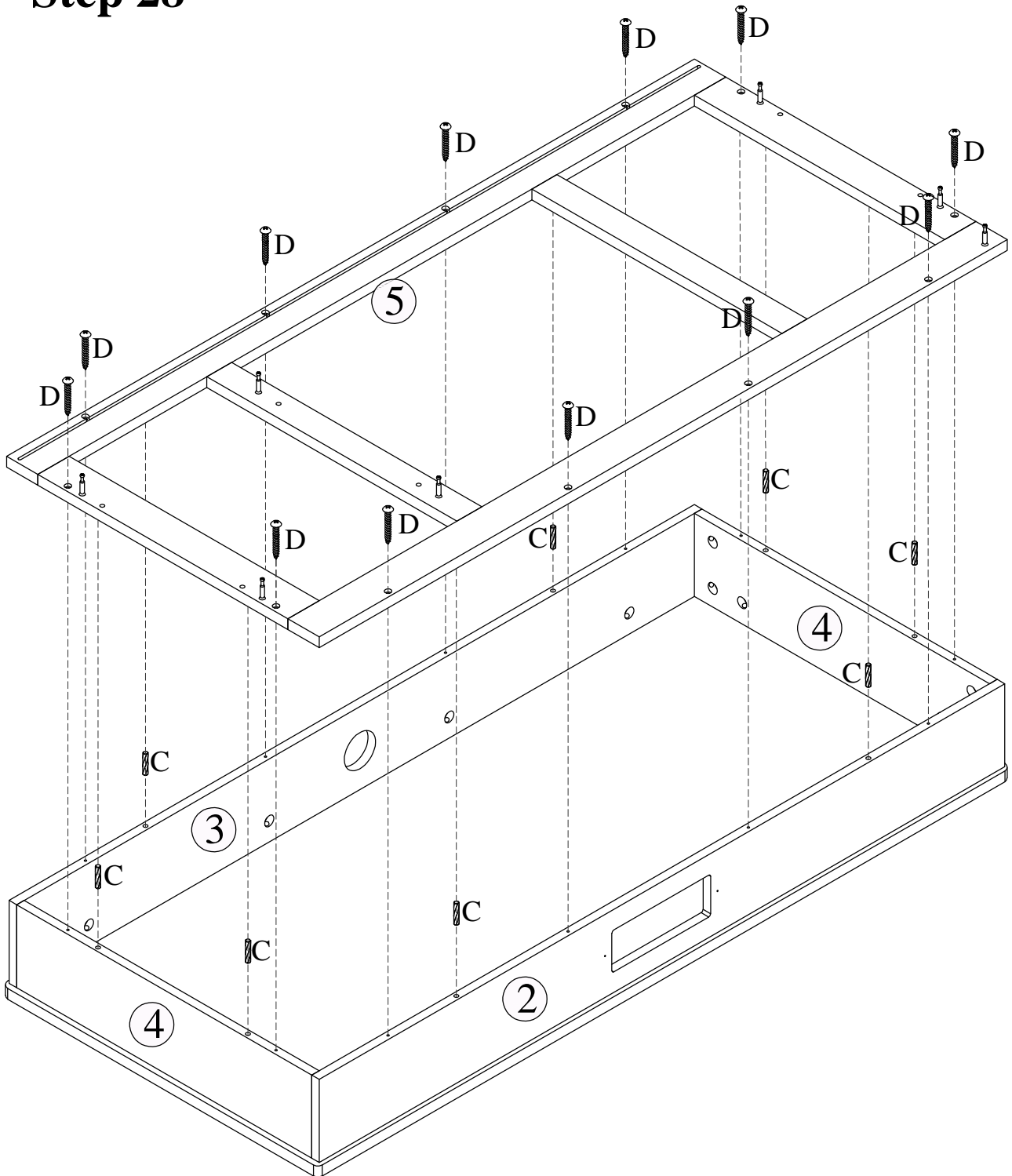

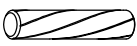
Step 28



	
Ø6*30mm	Ø4*35mm
C X 8	D X 12

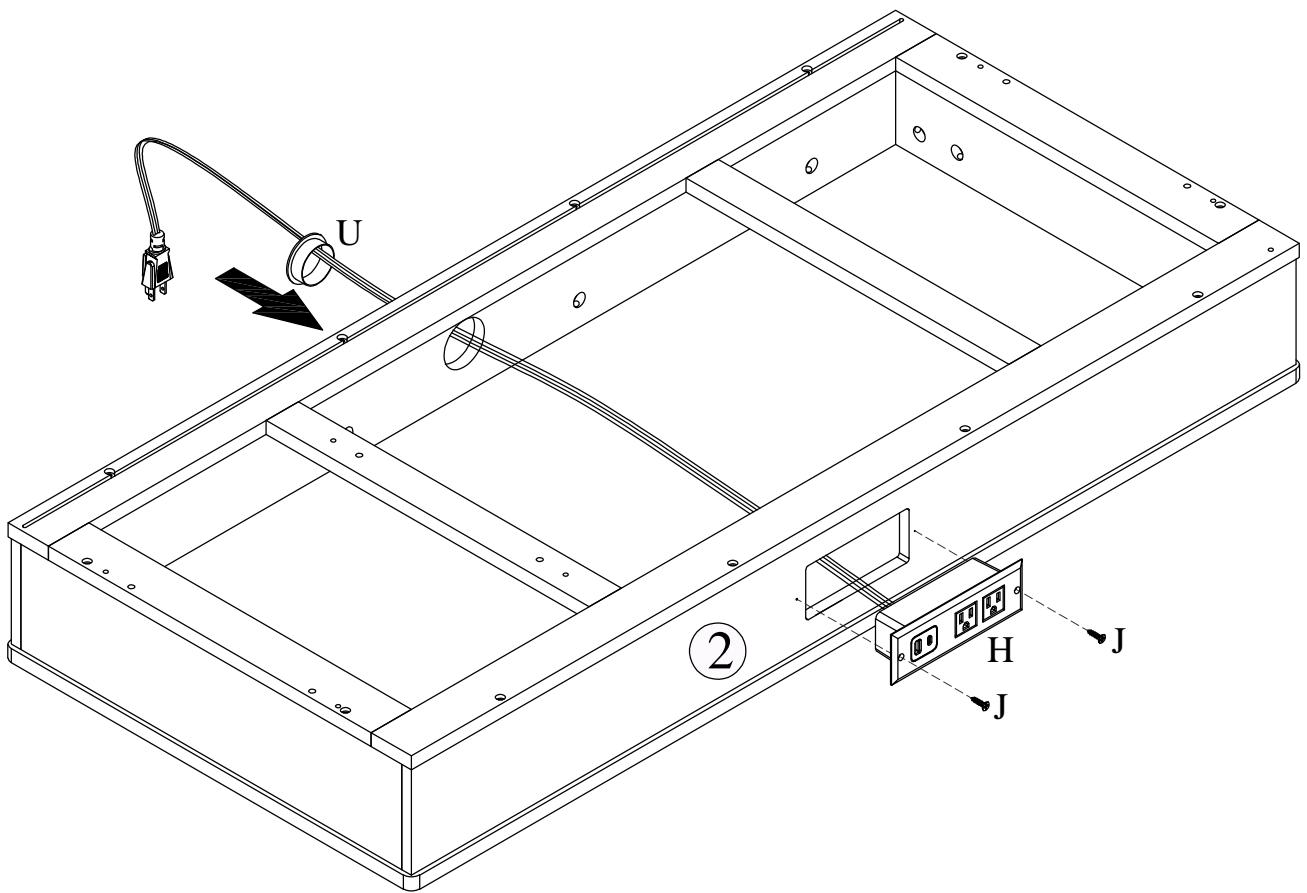

Step 29

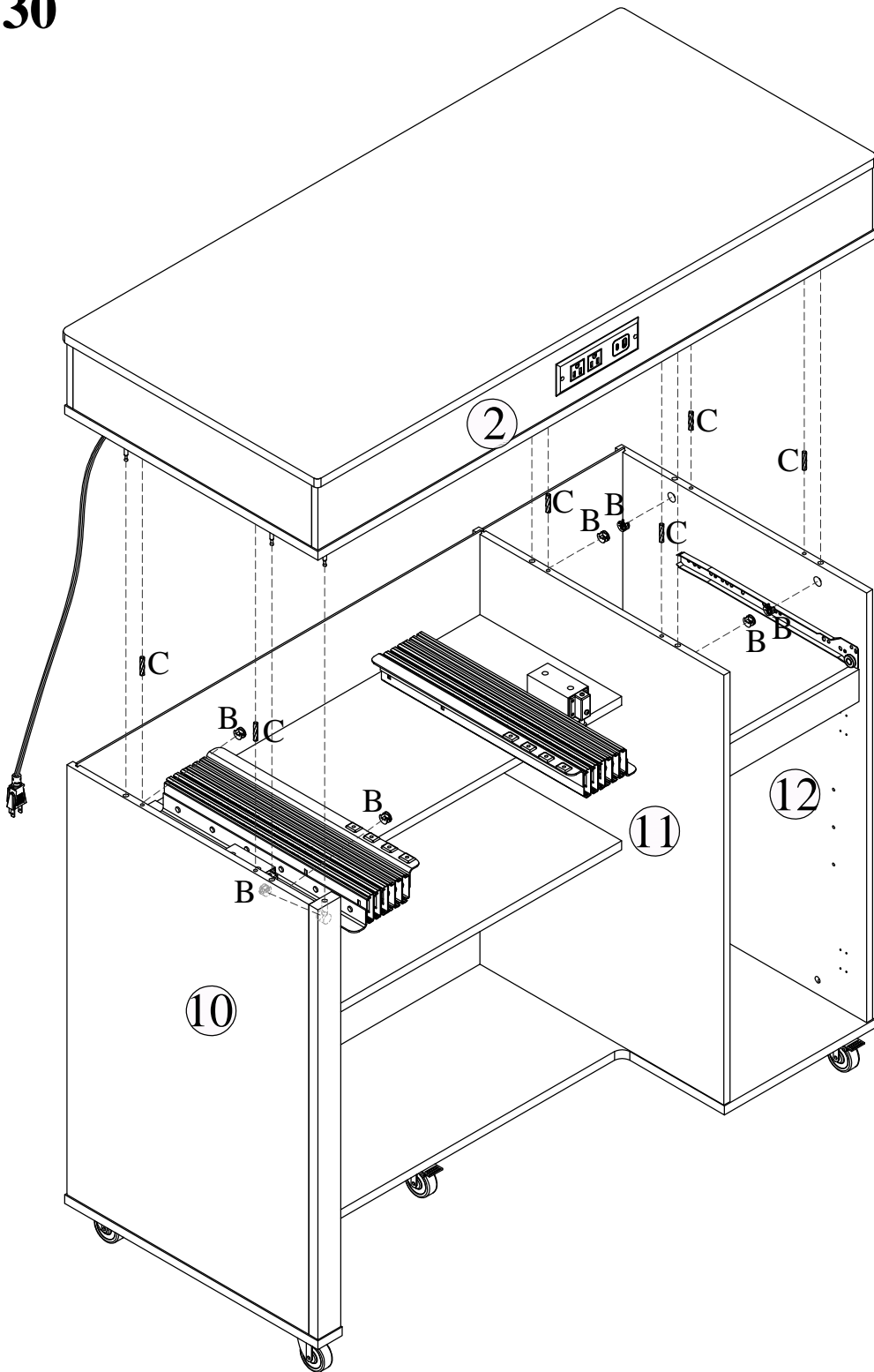

	 Ø3*12mm	
H X 1	J X 2	U X 1

Step 30



	
Ø15*9mm	Ø6*30mm
B X 7	C X 6

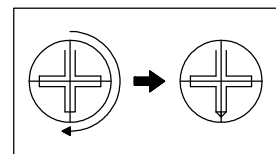

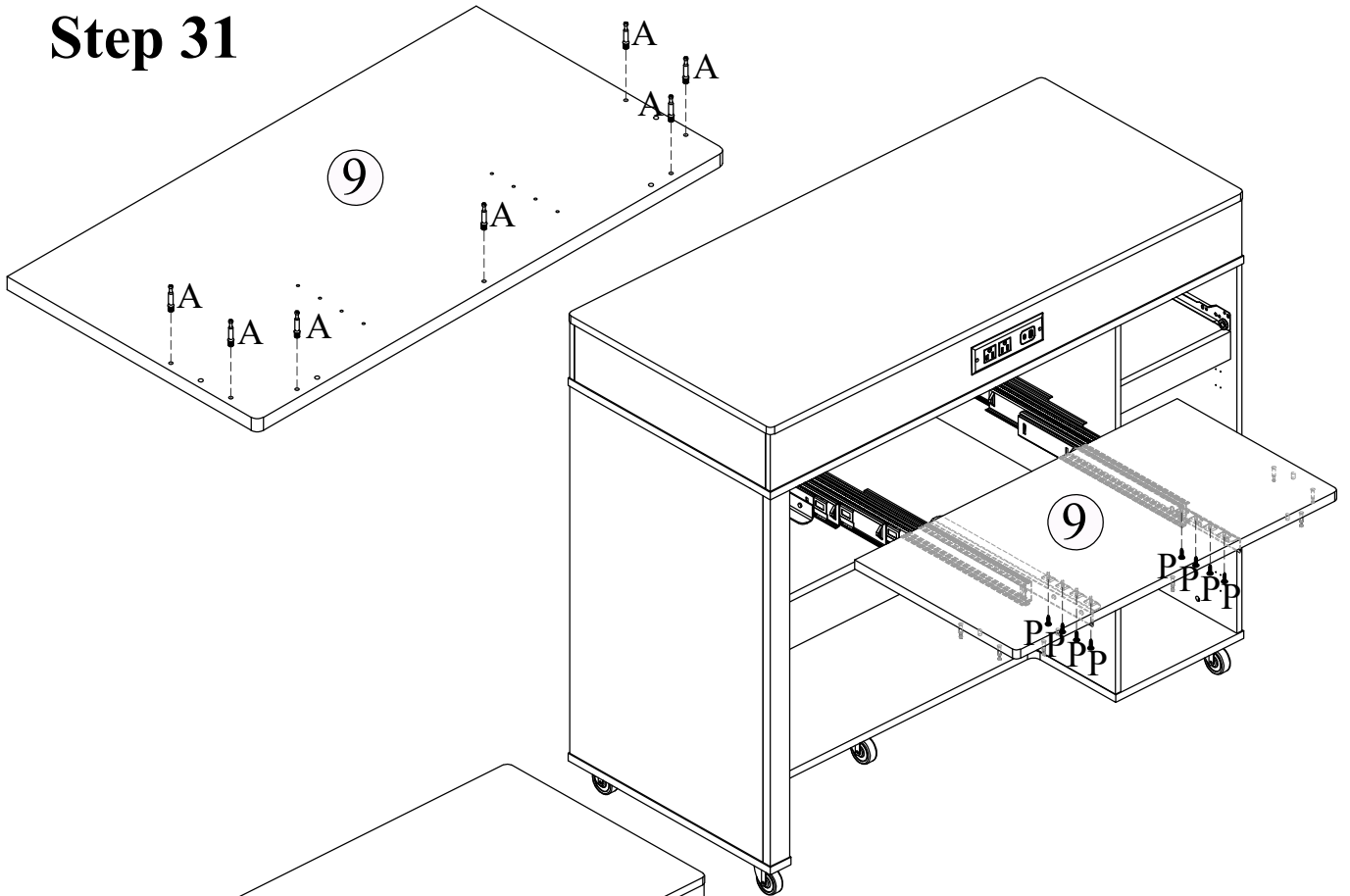

Lock Minifix cap clockwise

Step 31

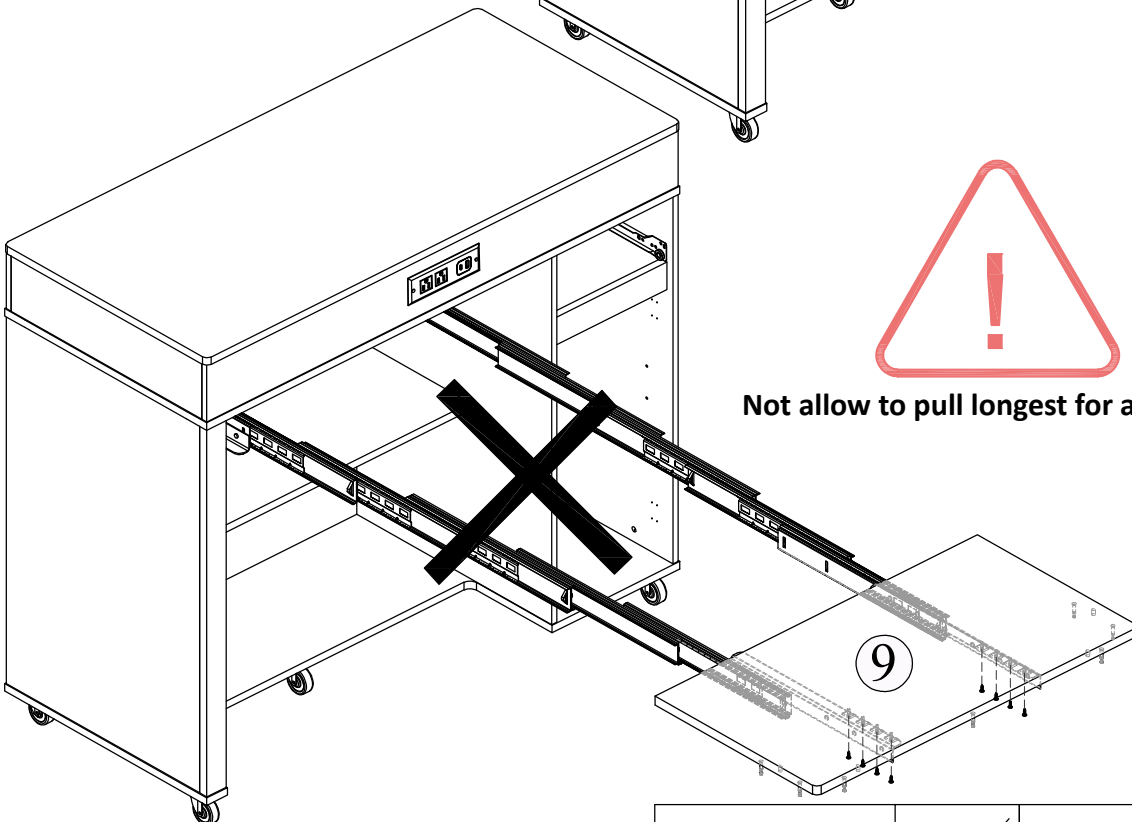

Not allow to pull longest for assembling.

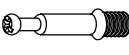

	
6.5*35mm	5*16mm
A X 7	P X 8

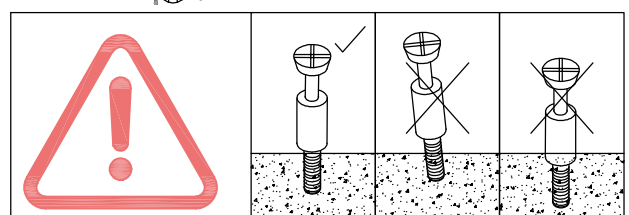

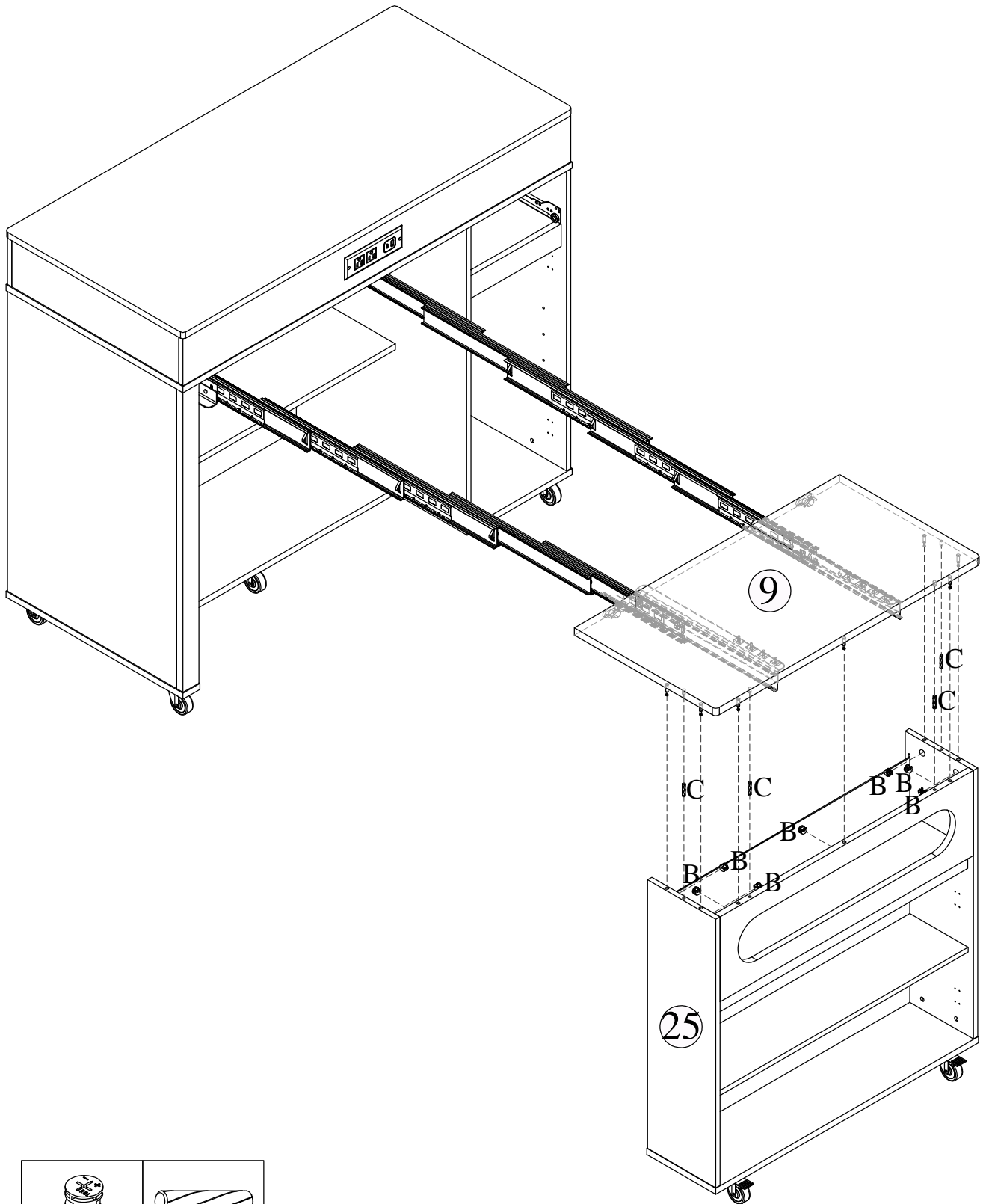

Step 32

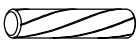

	
Ø15*9mm	Ø6*30mm
B X 7	C X 4

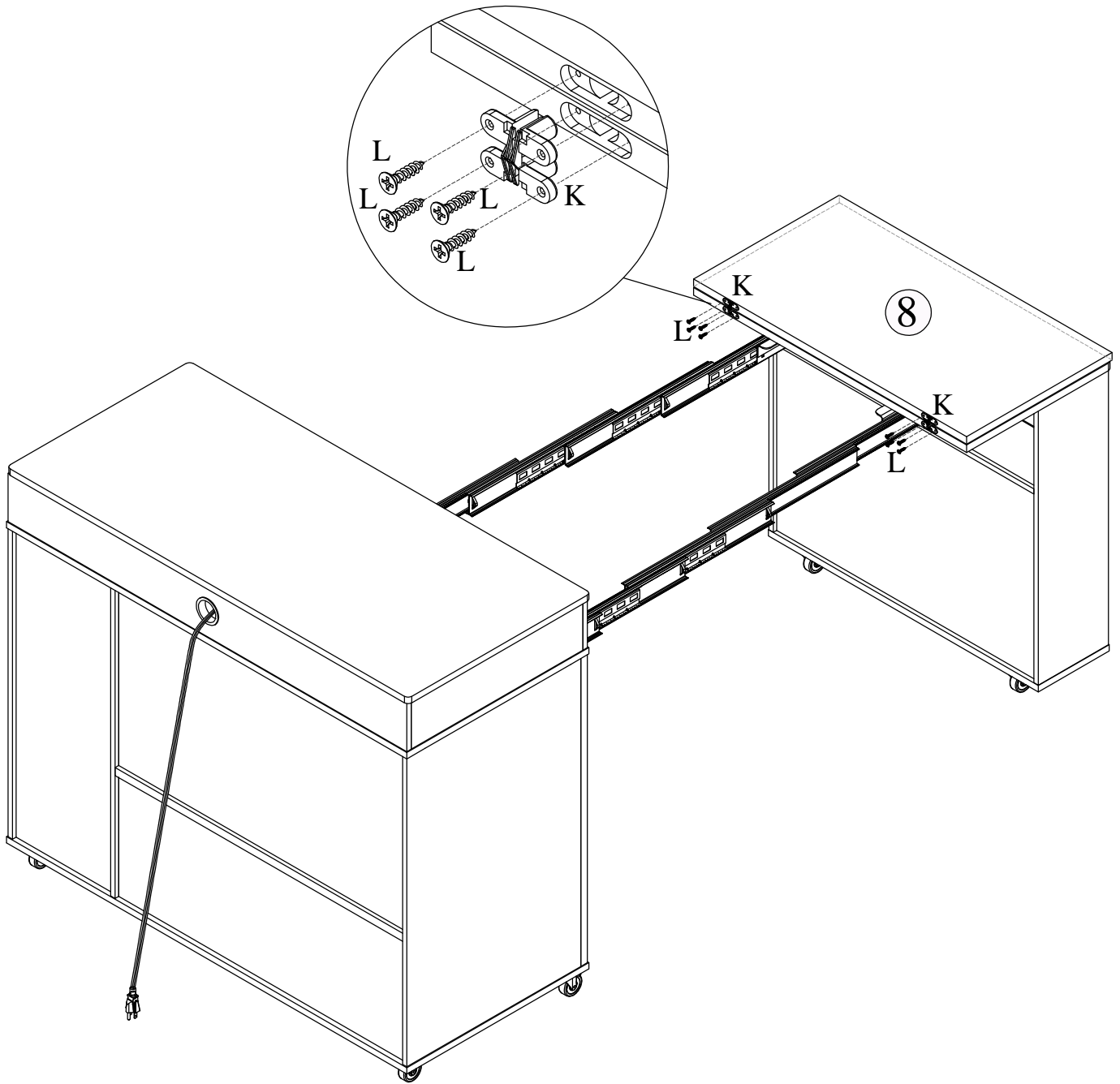

Step 33



	
K X 2	L X 8 Ø4*19mm

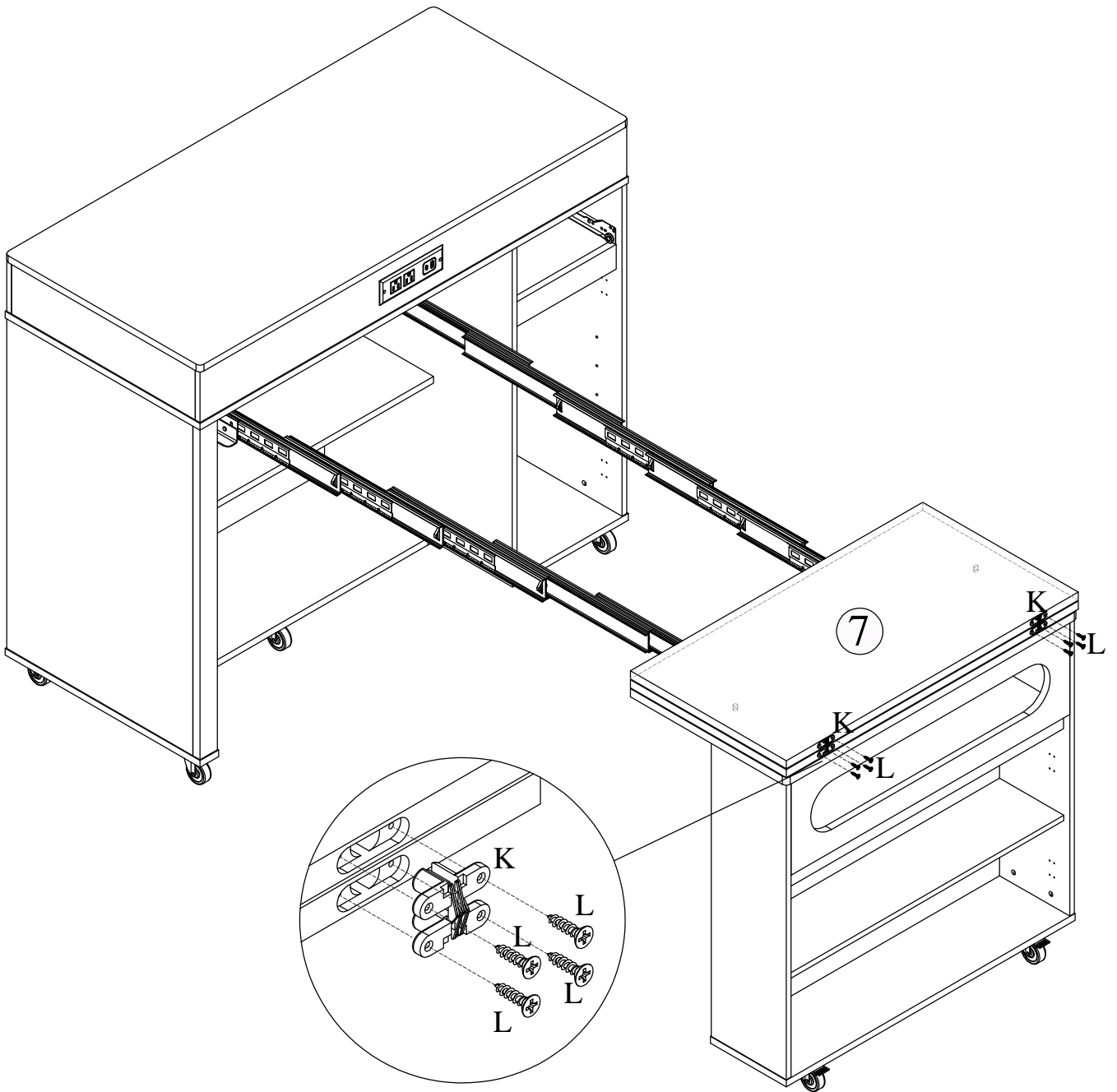

Step 34

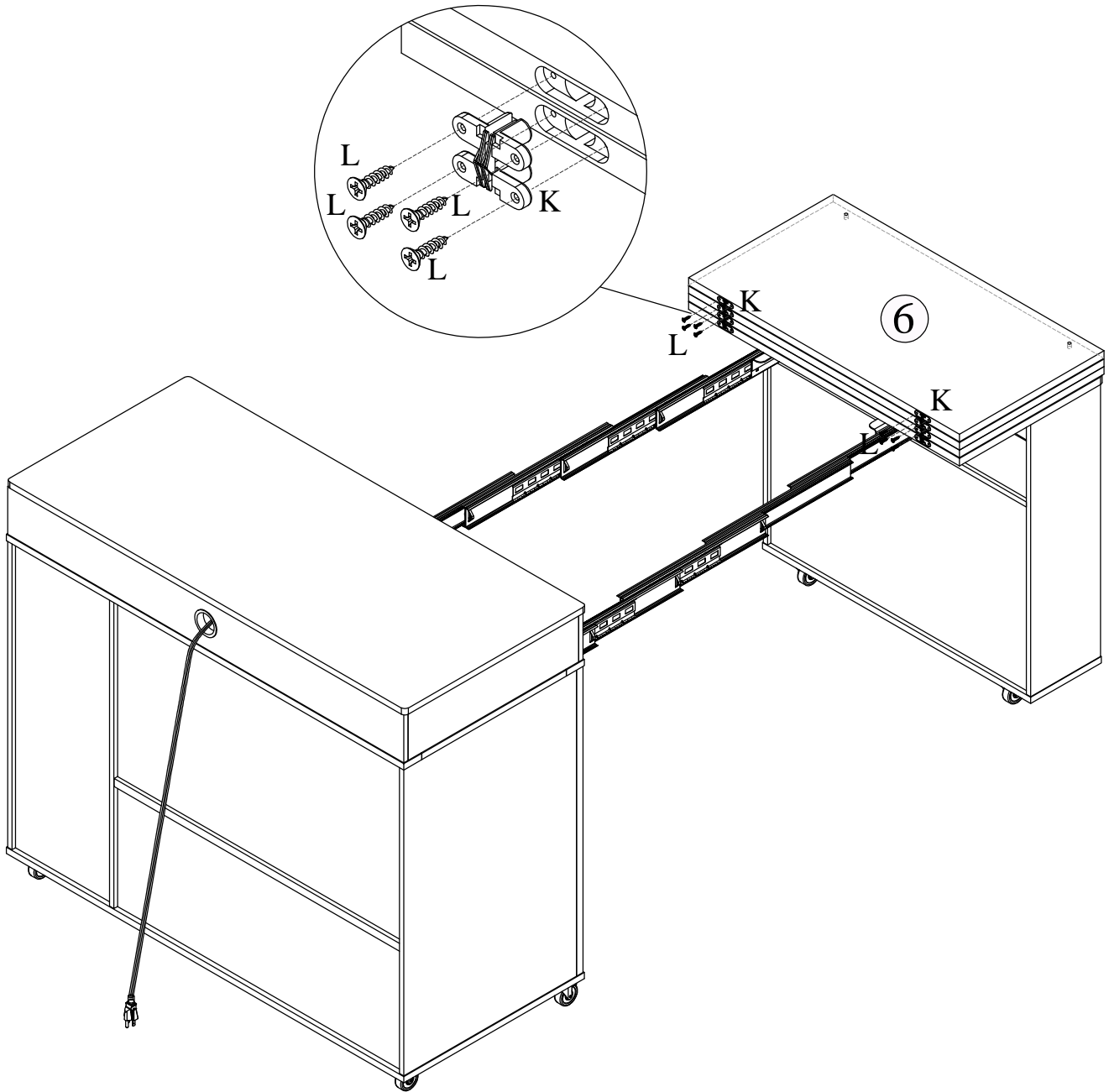

	
K X 2	04*19mm L X 8

Step 35



	
K X 2	04*19mm L X 8

Step 36

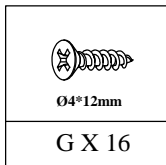
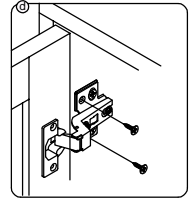
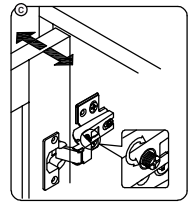
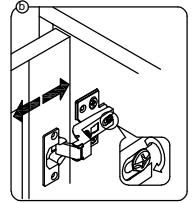
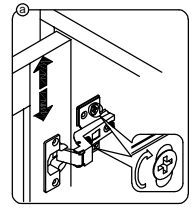
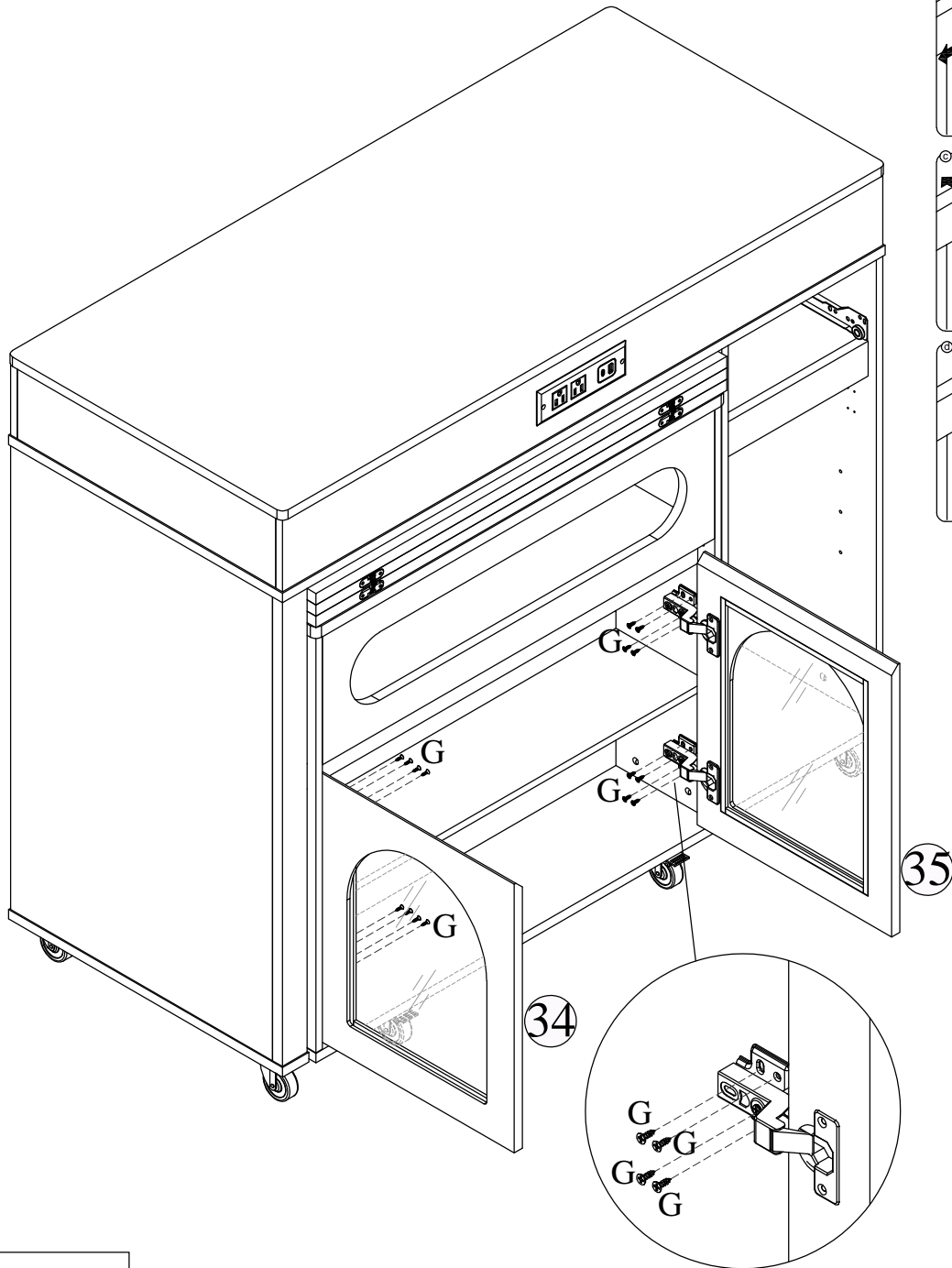

Step 37

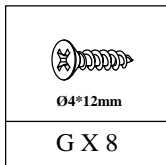
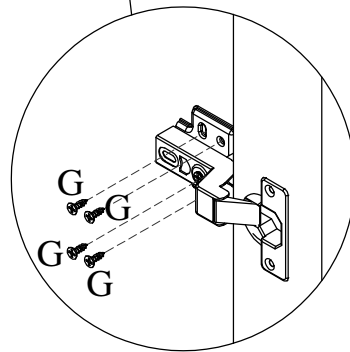
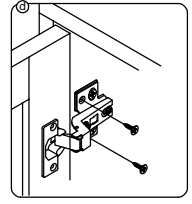
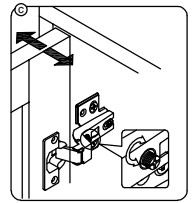
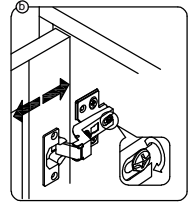
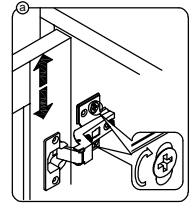
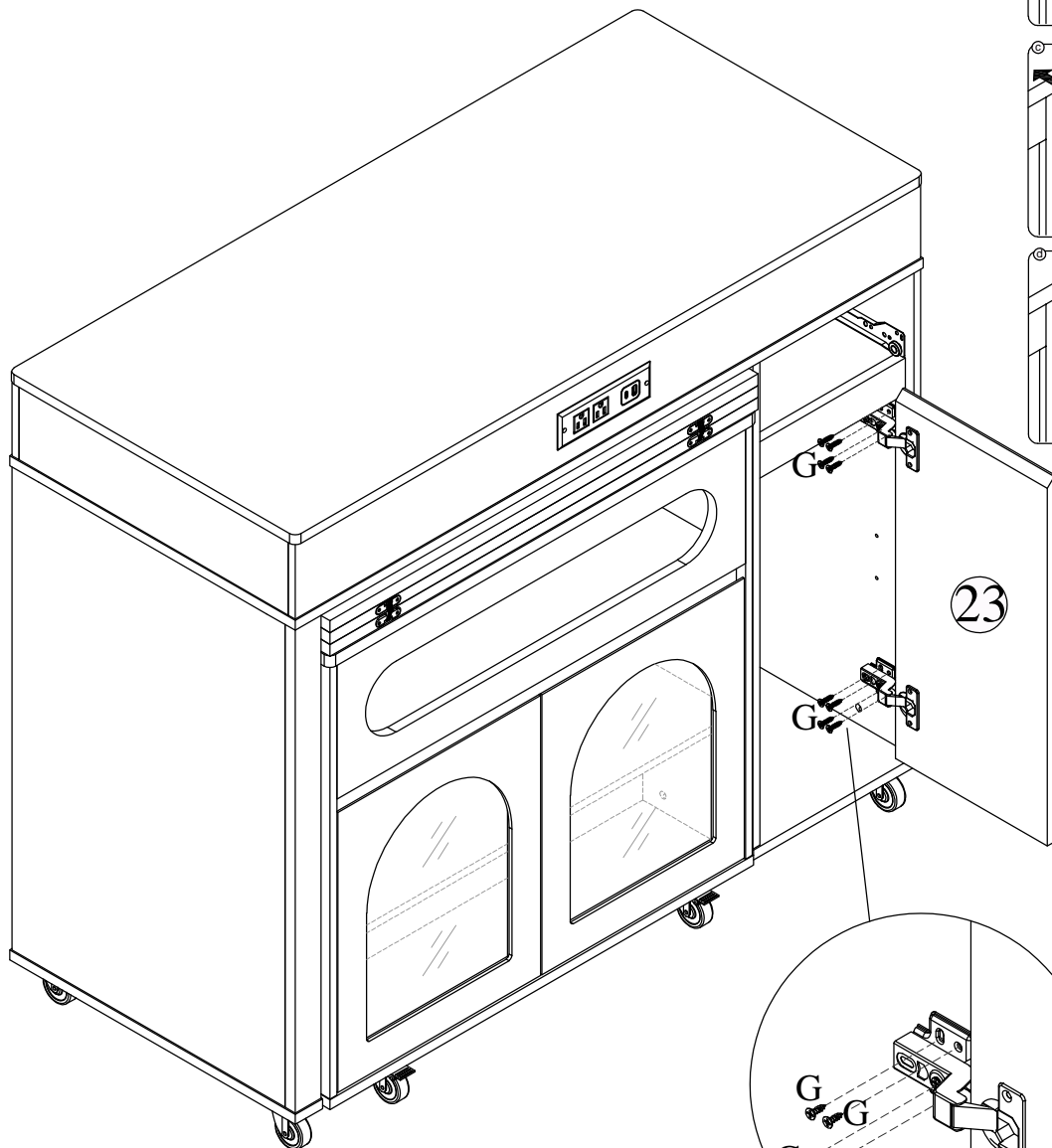

Step 38

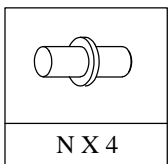
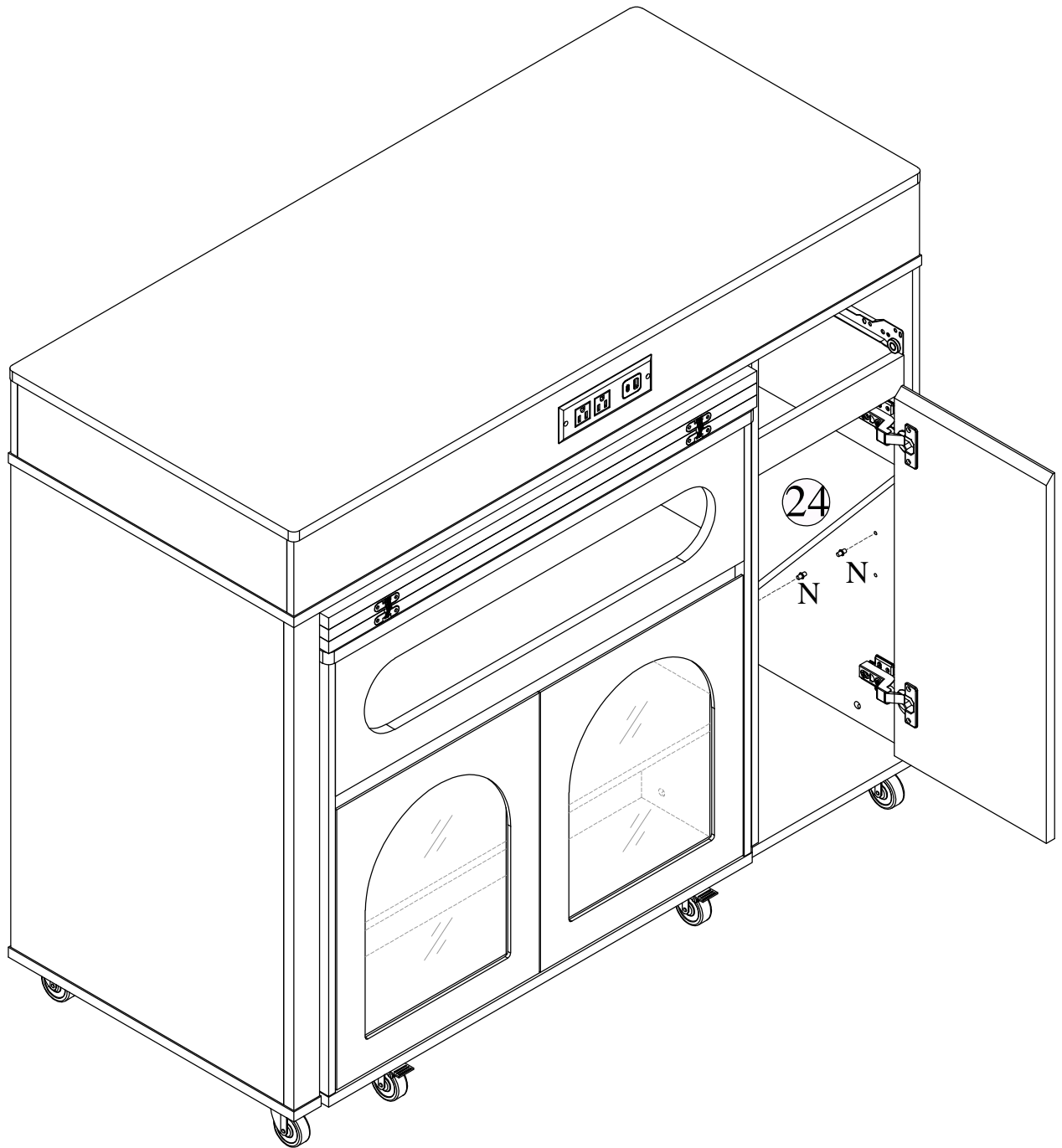

Step 39

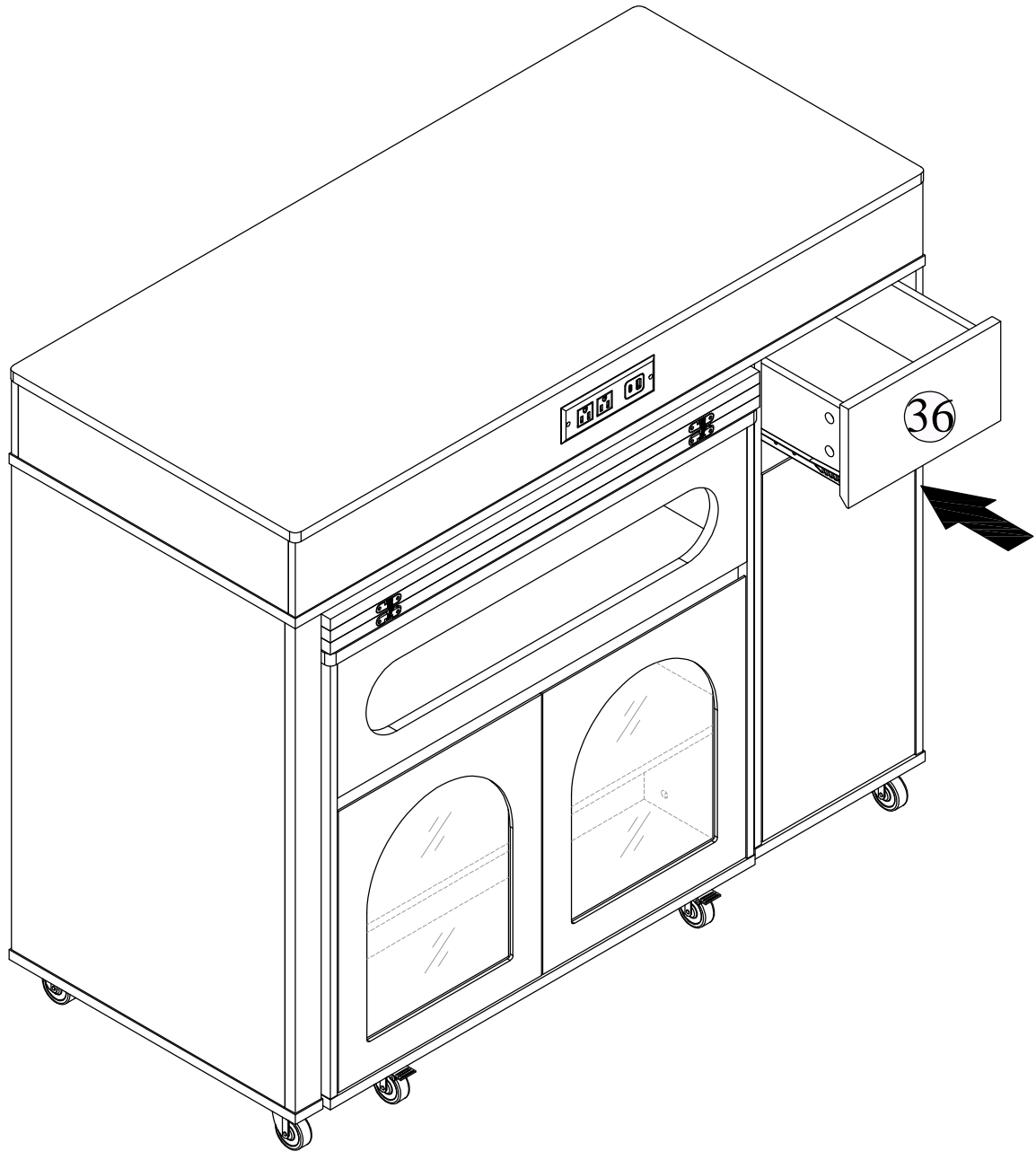

Step 40 Option 1:

Warning: Hands pinching.

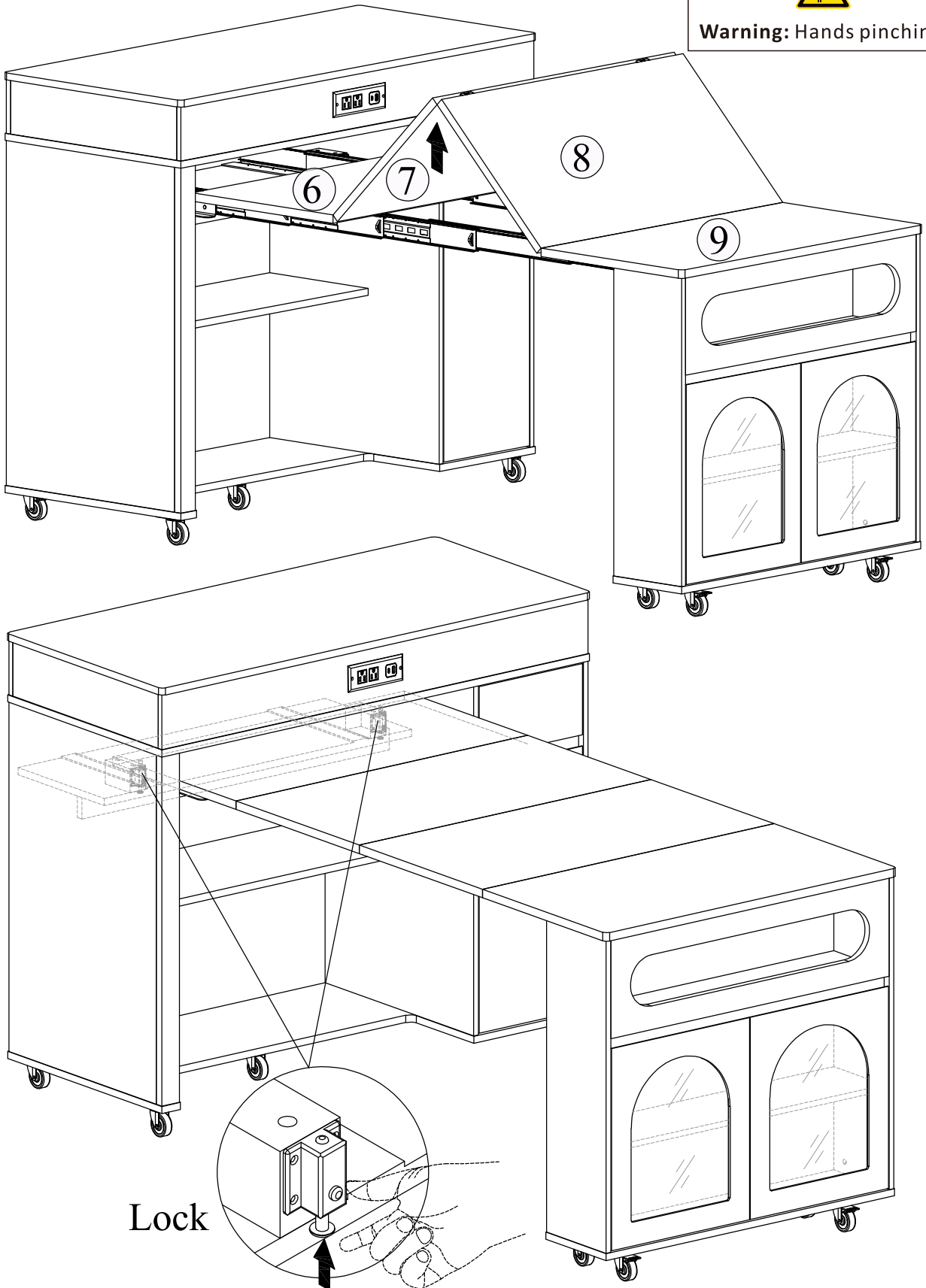

Step 41 Option 2:

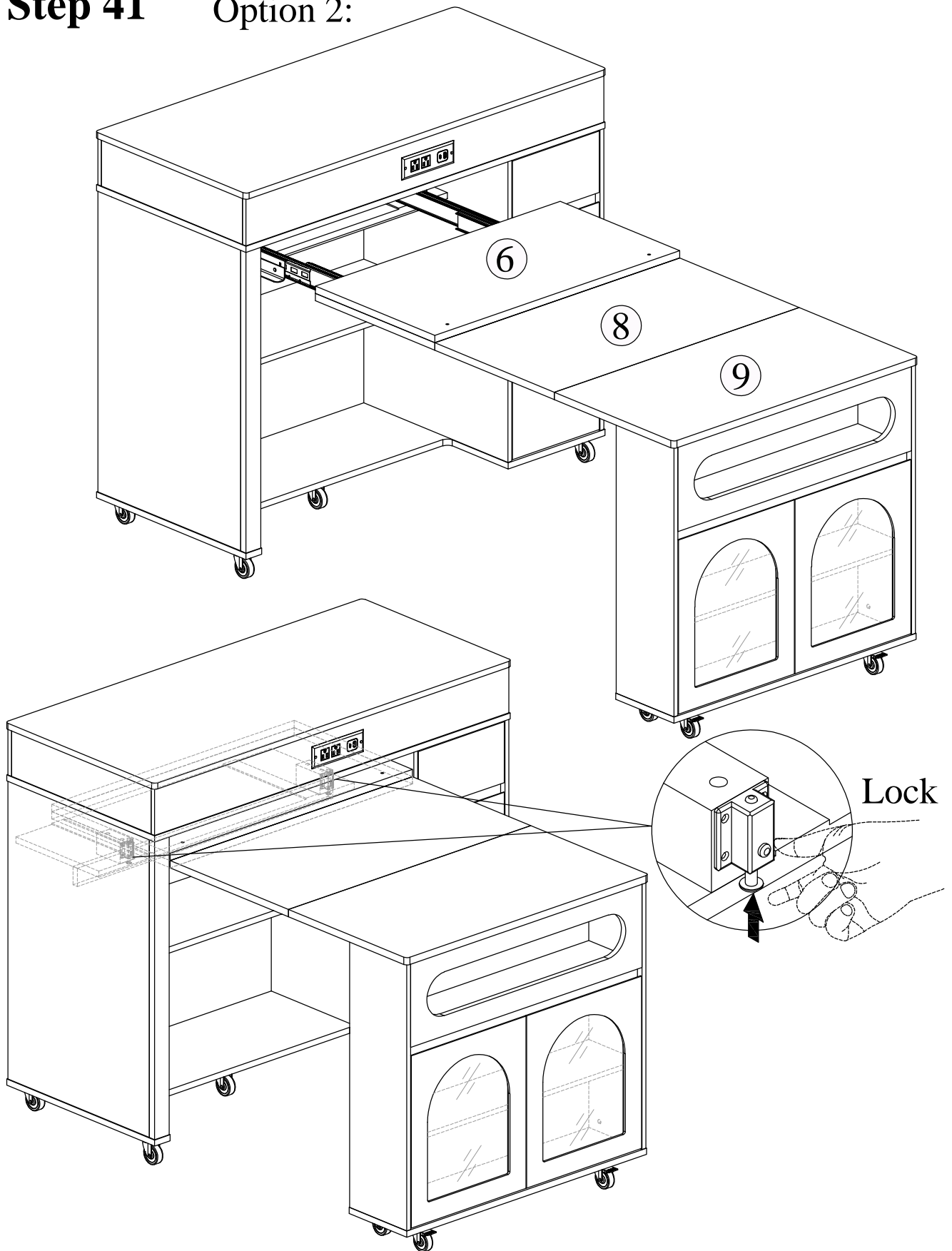

Step 42 Option 3:



Warning: Hands pinching.

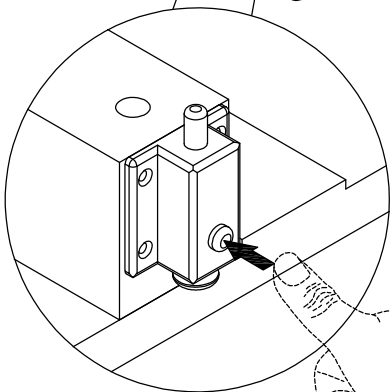
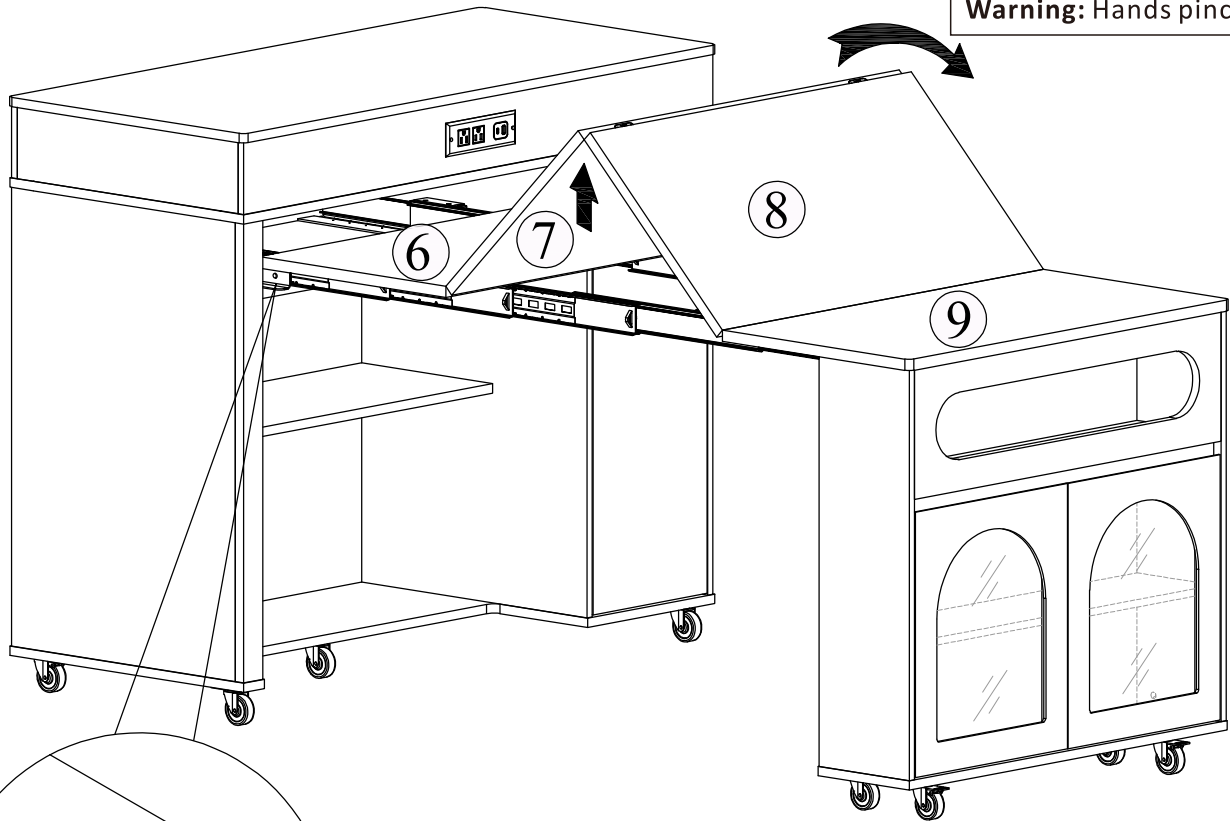

Unlock

