

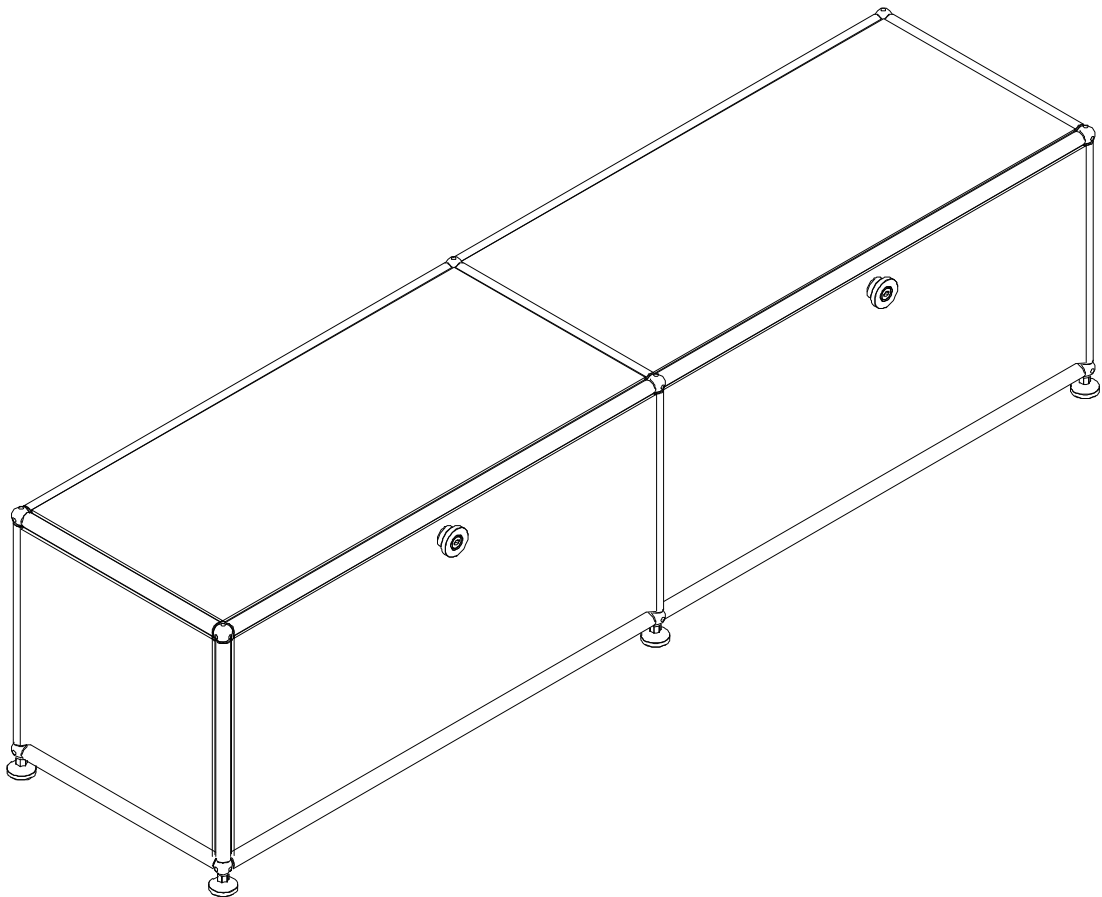



# ASSEMBLY INSTRUCTIONS



---

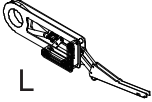
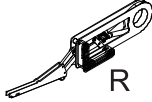
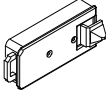
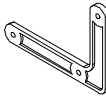

Storage Cabinets Type B

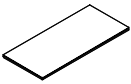
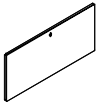
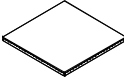
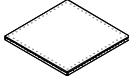
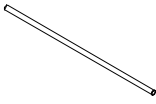
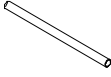

# Part List

①	②	③	④	⑤	⑥	⑦	⑧
							
x1	x2	x2	x1	x1	M3x28 x4	M4x25 x3	M4x14 x4

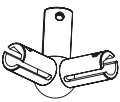
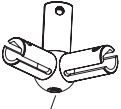
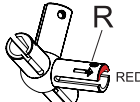
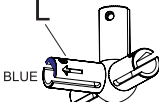
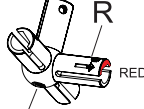
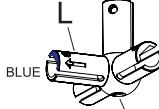
A	B	C	D	E1	E2	F	G
							
x6	x2	x2	x1	Long x8	Short x12	x2	x6

H1	H2	J1	J2	K1	K2	M	N
							
x4	x4	x1	x1	x1	x1	x40	x1

II

x1

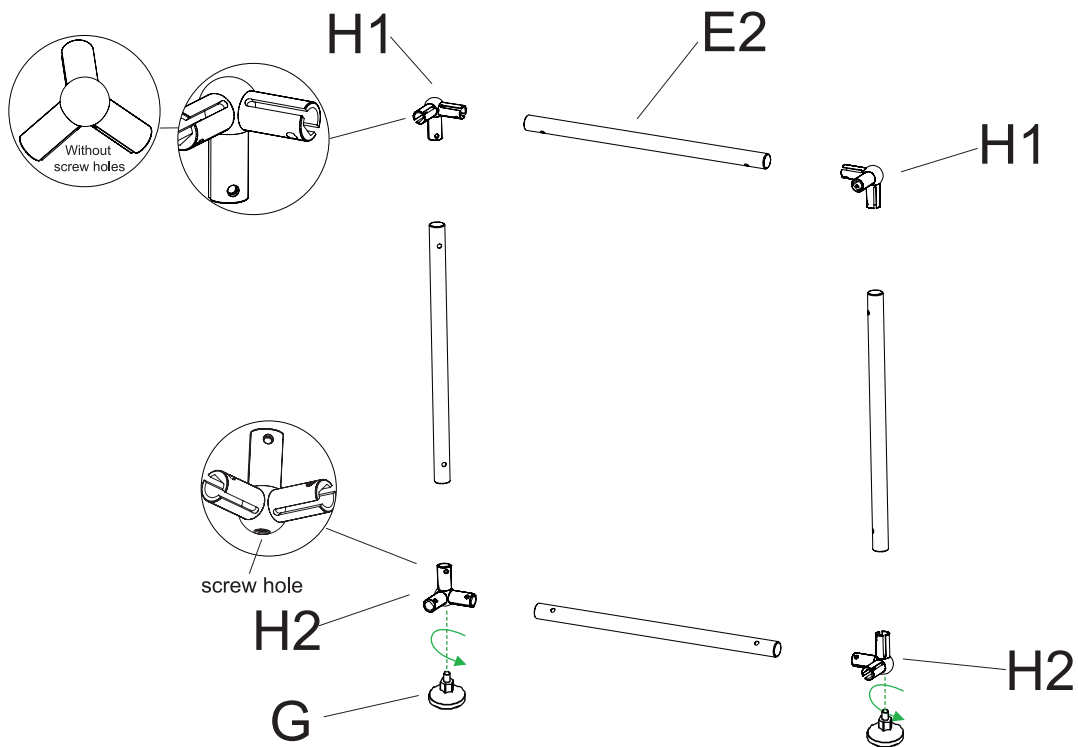
# Step1

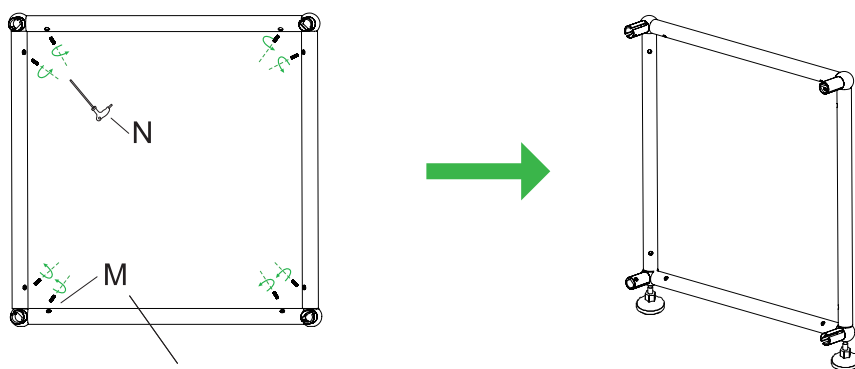

Gx2  
H1x2  
H2x2  
E2x4

# Step2



Do not tighten the **M** screws completely, otherwise it will not be possible to adjust the overall product later.

Mx8  
Step2x2

### Step3

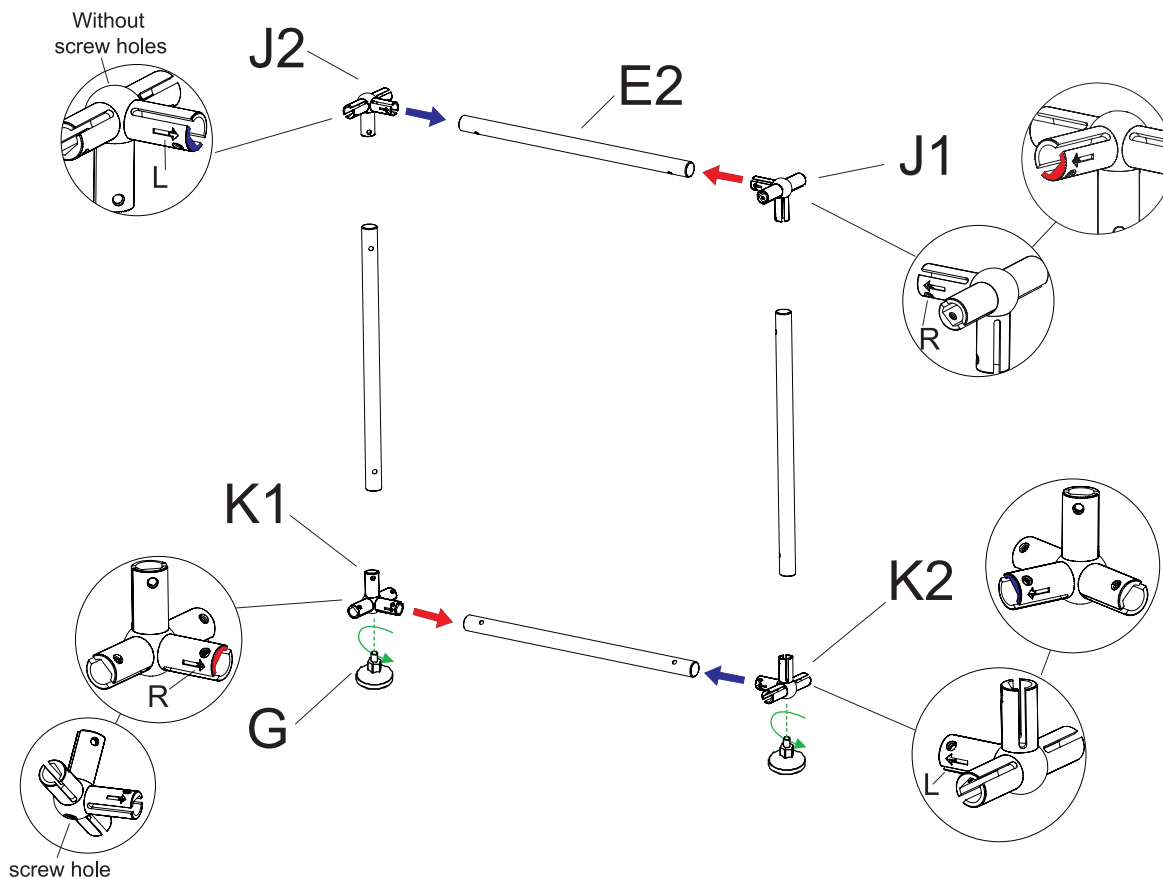

J1x1  
J2x1  
K1x1  
K2x1  
E2x4  
Gx2

### Step4

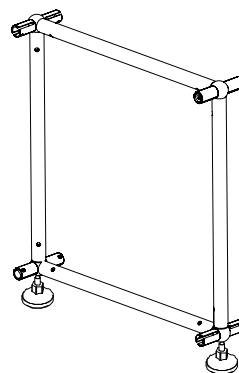
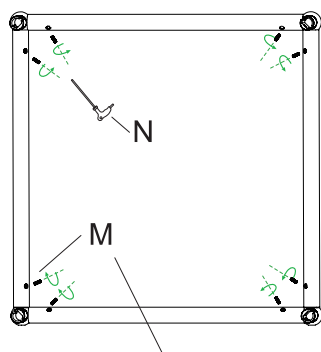

Do not tighten the **M** screws completely, otherwise it will not be possible to adjust the overall product later.

Mx8  
Step4x1

Step5

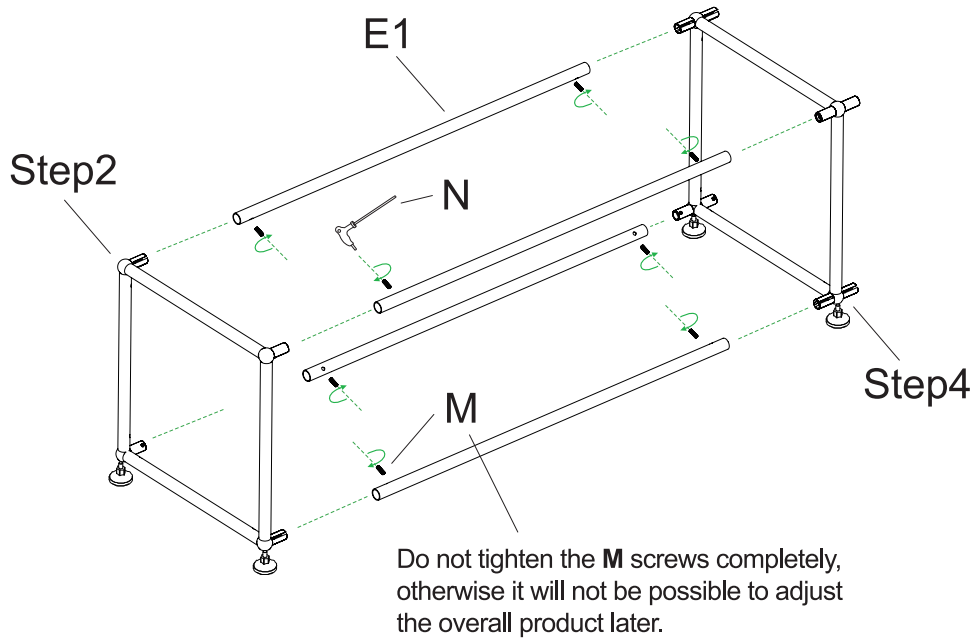

Mx8  
E1x4  
Step2x1  
Step4x1

Step6

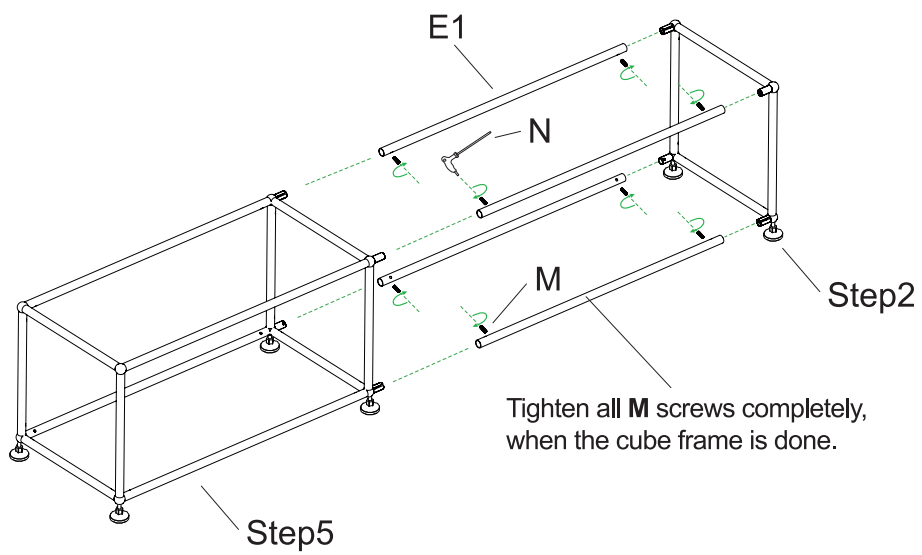

Mx8  
E1x4  
Step2x1  
Step5x1

### Step7

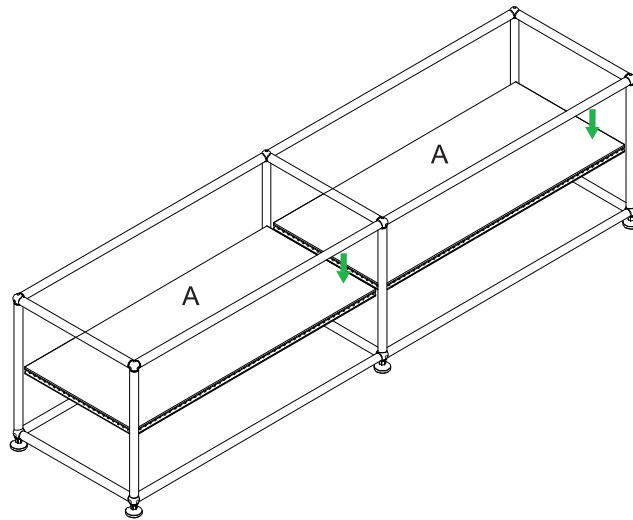

Ax2

### Step8

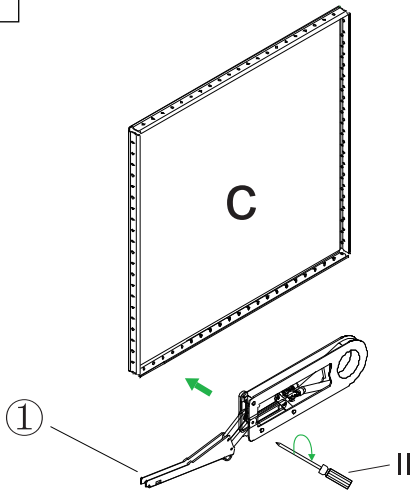

Partially unscrew the three screws in ① before installing it on the metal panel.

Cx1  
①x1  
Step8x1

### Step9

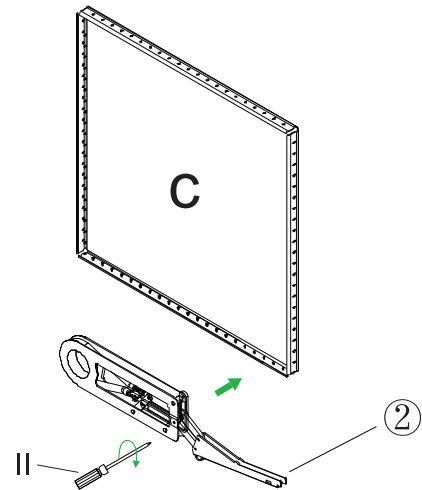

Partially unscrew the three screws in ② before installing it on the metal panel.

Cx1  
②x1  
Step9x1

### Step10

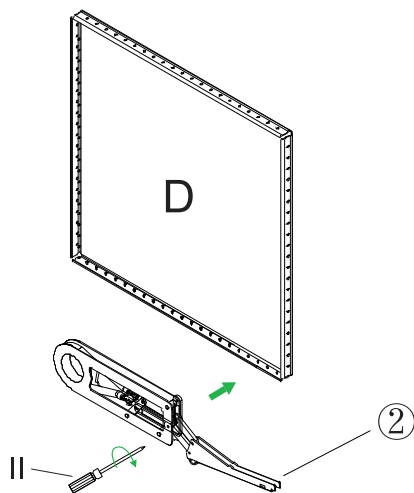

Partially unscrew the three screws in ② before installing it on the metal panel.

Dx1  
②x1  
Step10x1

### Step11

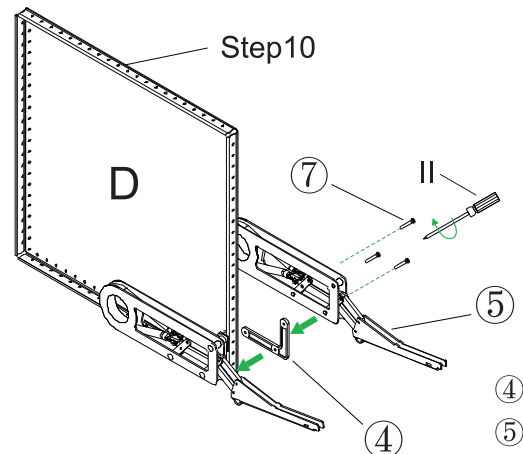

④x1  
⑤x1  
⑦x3  
Step10x1  
Step11x1

Step12

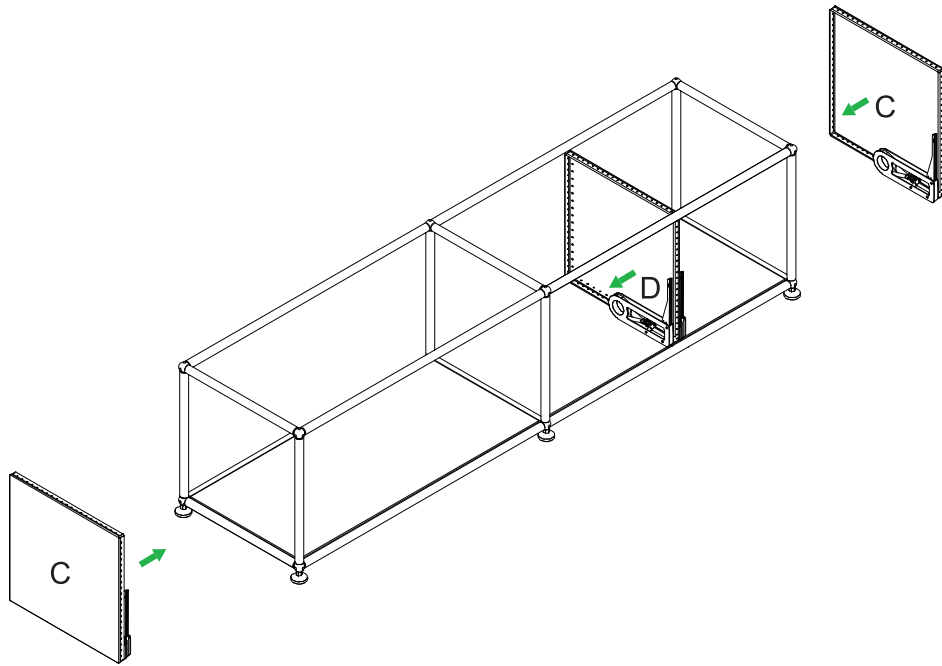

Step8x1  
Step9x1  
Step11x1

Step13

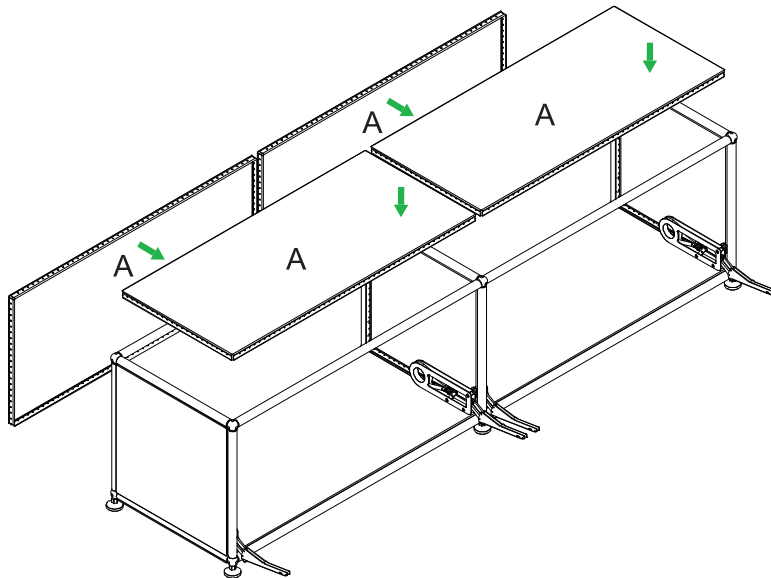

Ax4

### Step14

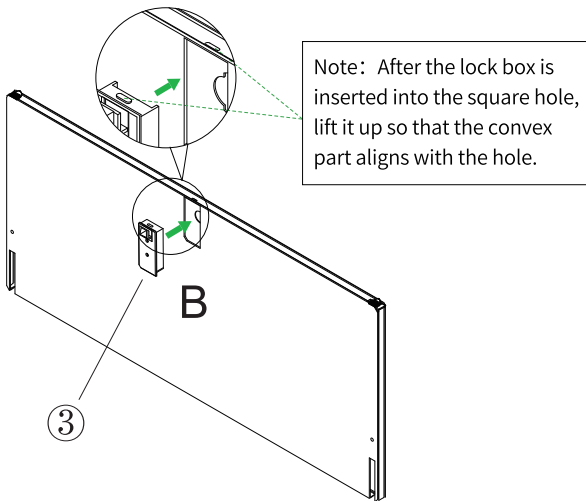

③x1  
Bx1

### Step15

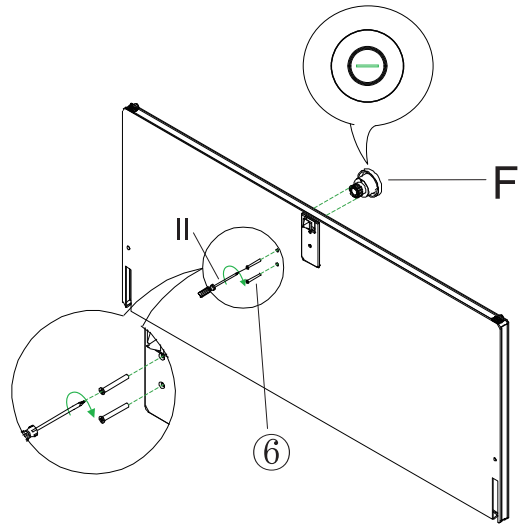

⑥x2  
Fx1  
Step15x2

### Step16

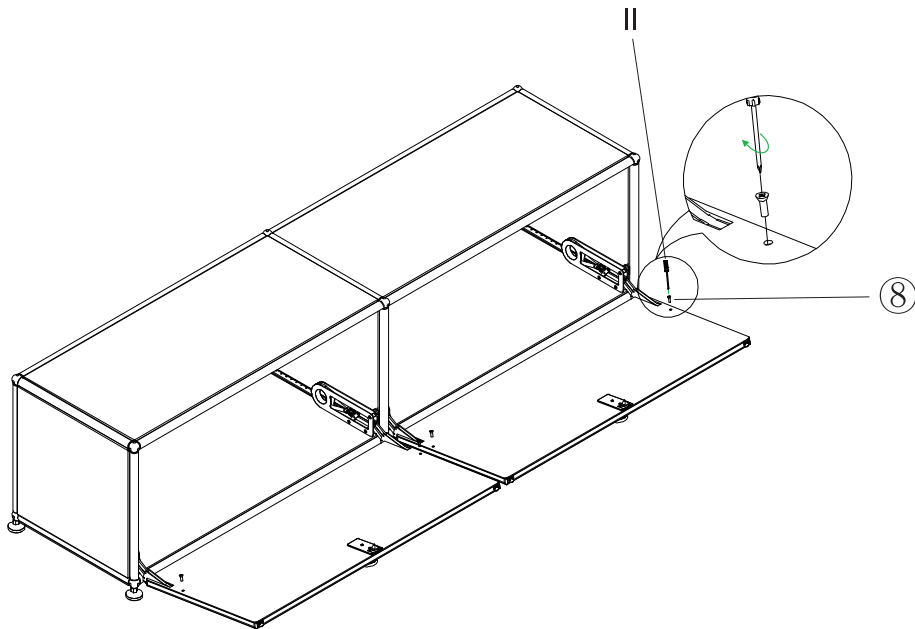

⑧x4

**Finish**

