

PORTABLE DEMIDIFIER

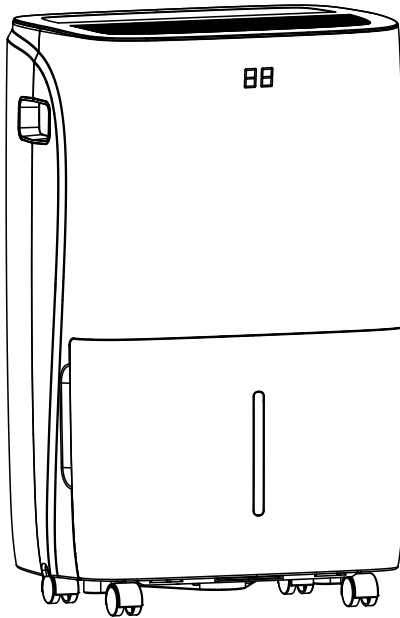

Model No.:D025D-25Pt3 D025D-35Pt3
Item No.:75025EDE0-WHITE 75025EDE1-WHITE

Model No.:D026D-50Pt3
Item No.:75026EDE0-WHITE

Please keep this manual carefully for further reference!

Thank you for selecting our dehumidifier. Be sure to read this manual carefully before using it. If you encounter any questions, please contact the professional service for help.



Scan the QR code to watch
the product videos.



Web: www.electacticshop.com



Email: service@electacticshop.com

CONTENTS

IMPORTANT SAFETY INSTRUCTIONS	1
PRODUCT OVERVIEW	9
BEFORE FIRST USE	
Positioning the Unit	10
Using the Unit	10
OPERATION INSTRUCTIONS	
Control Panel	11
Other Features	12
CLEANING & MAINTENANCE	
Draining the Collected Water	13
Cleaning the Dehumidifier	15
Storing the Dehumidifier	16
TROUBLESHOOTING	17

IMPORTANT SAFETY INSTRUCTIONS

1.1 General Safety Instructions

- Follow local grid interconnection rules while installing the dehumidifier and ensure that it is properly grounded. If you have any question on electrical installation, follow the instructions of the manufacturer, and if necessary, ask a professional electrician to install it.
- Do not install and use the dehumidifier in the bathroom or other humid environments.
- Place the machine in a flat and dry place and keep a distance of above 50cm between the machine and the surrounding objects or walls.
- When drainage pipes are installed, ensure that the drainage pipes are properly connected, and are not distorted or bended.
- Keep the air inlet and outlet free from obstructions.
- The appliance shall be installed in accordance with national wiring regulations.
- After the dehumidifier is installed, ensure that the power plug is intact and firmly plugged into the power outlet, and place the power cord orderly to prevent someone from being tripped or pulling out the plug.
- Do not put any object into the air inlet and outlet of the dehumidifier.
- Maintenance and repair requiring the assistance of other skilled personnel shall be carried out under the supervision of the person competent in the use of flammable refrigerants.
- All working procedure that affects safety means shall only be carried by competent persons. Examples for such working procedures are: • breaking into the refrigerating circuit; • opening of sealed components; • opening of ventilated enclosures.
- The dehumidifier is only suitable for indoor use, and is not suitable for other applications.
- While adjusting the upper and lower wind-guide strips of the air outlet, pluck it with hands gently to avoid damaging wind-guide strips.
- When moving the machine, make sure that it is in an upright position.
- The machine should stay away from gasoline, flammable gas, stoves and other heat sources.
- Don't disassemble, overhaul and modify the machine arbitrarily, otherwise it will cause a machine malfunction or even bring harm to persons and properties. To avoid danger, if a machine failure occurs, ask the manufacturer or professionals to repair it.
- Do not pull the plug to turn off the machine.
- Do not place cups or other objects on the body to prevent water or other liquids from spilling into the dehumidifier.
- Do not use insecticide sprays or other flammable substances near the dehumidifier.
- Do not wipe or wash the dehumidifier with chemical solvents such as gasoline and alcohol. When you need to clean the dehumidifier, you must disconnect the power supply, and clean it with a half-wet soft cloth. If the machine is really dirty, scrub with a mild detergent.
- Children shall not play with the appliance. Cleaning and maintenance shall not be made by children without supervision.

- **If the supply cord is damaged, it must be replaced by the manufacturer, its service agent or similarly qualified persons in order to avoid a hazard.**
- **The appliance shall be stored so as to prevent mechanical damage from occurring.**
- Plug into a grounded 3 prong outlet
- Do not use an extension cord
- Do not remove ground prong
- Do not use an electrical adapter
- Unplug the dehumidifier before servicing

I.2 Special Safety Instructions for using flammable refrigerant

1. Transport of equipment containing flammable refrigerants

Compliance with the transport regulations

2. Marking of equipment using signs

Compliance with local regulations

3. Disposal of equipment using flammable refrigerants

Compliance with national regulations

4. Storage of equipment/appliances

The storage of equipment should be in accordance with the manufacturer's instructions.

5. Storage of packed (unsold) equipment

- Storage package protection should be constructed such that mechanical damage to the equipment inside the package will not cause a leak of the refrigerant charge.
- The maximum number of pieces of equipment permitted to be stored together will be determined by local regulations.

6. Information on servicing

6-1 Checks to the area

- Prior to beginning work on systems containing flammable refrigerants, safety checks are necessary to ensure that the risk of ignition is minimised.
- For repair to the refrigerating system, the following precautions shall be complied with prior to conducting work on the system.

6-2 Work procedure

Work shall be undertaken under a controlled procedure so as to minimise the risk of a flammable gas or vapour being present while the work is being performed.

6-3 General work area

- All maintenance staff and others working in the local area shall be instructed on the nature of work being carried out. Work in confined spaces shall be avoided.
- The area around the workspace shall be sectioned off. Ensure that the conditions within the area have been made safe by control of flammable material.

6-4 Checking for presence of refrigerant

- The area shall be checked with an appropriate refrigerant detector prior to and during work, to ensure the technician is aware of potentially flammable atmospheres.
- Ensure that the leak detection equipment being used is suitable for use with flammable refrigerants, i.e. non-sparking, adequately sealed or intrinsically safe.

6-5 Presence of fire extinguisher

- If any hot work is to be conducted on the refrigeration equipment or any associated parts, appropriate fire extinguishing equipment shall be available to hand.

- Have a dry powder or CO2 fire extinguisher adjacent to the charging area.

6-6 No ignition sources • No person carrying out work in relation to a refrigeration system which involves exposing any pipe work that contains or has contained flammable refrigerant shall use any sources of ignition in such a manner that it may lead to the risk of fire or explosion.

- All possible ignition sources, including cigarette smoking, should be kept sufficiently far away from the site of installation, repairing, removing and disposal, during which flammable refrigerant can possibly be released to the surrounding space.

- Prior to work taking place, the area around the equipment is to be surveyed to make sure that there are no flammable hazards or ignition risks. "No Smoking" signs shall be displayed.

6-7 Ventilated area

Ensure that the area is in the open or that it is adequately ventilated before breaking into the system or conducting any hot work.

A degree of ventilation shall continue during the period that the work is carried out.

The ventilation should safely disperse any released refrigerant and preferably expel it externally into the atmosphere.

6-8 Checks to the refrigeration equipment

- Where electrical components are being changed, they shall be fit for the purpose and to the correct specification.

- At all times the manufacturer's maintenance and service guidelines shall be followed. If in doubt consult the manufacturer's technical department for assistance.

- The following checks shall be applied to installations using flammable refrigerants:

- The charge size is in accordance with the room size within which the refrigerant containing parts are installed;

- The ventilation machinery and outlets are operating adequately and are not obstructed;

- If an indirect refrigerating circuit is being used, the secondary circuit shall be checked for the presence of refrigerant;

- Marking to the equipment continues to be visible and legible. Markings and signs that are illegible shall be corrected;

- Refrigeration pipe or components are installed in a position where they are unlikely to be exposed to any substance which may corrode refrigerant containing components, unless the components are constructed of materials which are inherently resistant to being corroded or are suitably protected against being so corroded.

6-9 Checks to electrical devices

- Repair and maintenance to electrical components shall include initial safety checks and component inspection procedures.

- If a fault exists that could compromise safety, then no electrical supply shall be connected to the circuit until it is satisfactorily dealt with.

- If the fault cannot be corrected immediately but it is necessary to continue operation, an adequate temporary solution shall be used.

- This shall be reported to the owner of the equipment so all parties are advised.

- Initial safety checks shall include:

- That capacitors are discharged: this shall be done in a safe manner to avoid possibility of sparking;

- That there are no live electrical components and wiring are exposed while charging, recovering or purging the system;

- That there is continuity of earth bonding.

7. Sealed electrical components shall be replaced.

8. Intrinsically safe components must be replaced.

9. Cabling

- Check that cabling will not be subject to wear, corrosion, excessive pressure, vibration, sharp edges or any other adverse environmental effects.
- The check shall also take into account the effects of aging or continual vibration from sources such as compressors or fans.

10. Detection of flammable refrigerants

- Under no circumstances shall potential sources of ignition be used in the searching for or detection of refrigerant leaks.
- A halide torch (or any other detector using a naked flame) shall not be used.

11. Leak detection methods

- The following leak detection methods are deemed acceptable for systems containing flammable refrigerants:
 - Electronic leak detectors shall be used to detect flammable refrigerants, but the sensitivity may not be adequate, or may need re-calibration. (Detection equipment shall be calibrated in a refrigerant-free area.)
 - Ensure that the detector is not a potential source of ignition and is suitable for the refrigerant used.
 - Leak detection equipment shall be set at a percentage of the LFL of the refrigerant and shall be calibrated to the refrigerant employed and the appropriate percentage of gas (25 % maximum) is confirmed.
 - Leak detection fluids are suitable for use with most refrigerants but the use of detergents containing chlorine shall be avoided as the chlorine may react with the refrigerant and corrode the copper pipe-work.
 - If a leak is suspected, all naked flames shall be removed/ extinguished.
 - If a leakage of refrigerant is found which requires brazing, all of the refrigerant shall be recovered from the system, or isolated (by means of shut off valves) in a part of the system remote from the leak.
 - Oxygen free nitrogen (OFN) shall then be purged through the system both before and during the brazing process.

12. Removal and evacuation

- When breaking into the refrigerant circuit to make repairs – or for any other purpose – conventional procedures shall be used. However, for flammable refrigerants it is important that best practice be followed, since flammability is a consideration. The following procedure shall be adhered to:
 - safely remove refrigerant following local and national regulations;
 - evacuate;
 - purge the circuit with inert gas (optional for A2L);
 - evacuate (optional for A2L);
 - continuously flush or purge with inert gas when using flame to open circuit; and
 - open the circuit.
- The refrigerant charge shall be recovered into the correct recovery cylinders if venting is not allowed by local and national codes. For appliances containing flammable refrigerants, the system shall be purged with oxygen-free nitrogen to render the appliance safe for flammable refrigerants. This process might need to be repeated several times. Compressed air or oxygen shall not be used for purging refrigerant systems.

- For appliances containing flammable refrigerants, refrigerants purging shall be achieved by breaking the vacuum in the system with oxygen-free nitrogen and continuing to fill until the working pressure is achieved, then venting to atmosphere, and finally pulling down to a vacuum (optional for A2L). This process shall be repeated until no refrigerant is within the system (optional for A2L). When the final oxygen-free nitrogen charge is used, the system shall be vented down to atmospheric pressure to enable work to take place.
- The outlet for the vacuum pump shall not be close to any potential ignition sources, and ventilation shall be available.

13.Charging procedures

- In addition to conventional charging procedures, the following requirements shall be followed:
 - Ensure that contamination of different refrigerants does not occur when using charging equipment.
 - Hoses or lines shall be as short as possible to minimise the amount of refrigerant contained in them.
 - Cylinders shall be kept upright.
 - Ensure that the refrigeration system is earthed prior to charging the system with refrigerant.
 - Label the system when charging is complete (if not already).
 - Extreme care shall be taken not to overfill the refrigeration system.
- Prior to recharging the system it shall be pressure tested with OFN.
- The system shall be leak tested on completion of charging but prior to commissioning.
- A follow up leak test shall be carried out prior to leaving the site.

14.Decommissioning

- Before carrying out this procedure, it is essential that the technician is completely familiar with the equipment and all its detail.
- It is recommended good practice that all refrigerants are recovered safely.
- Prior to the task being carried out, an oil and refrigerant sample shall be taken in case analysis is required prior to re-use of reclaimed refrigerant. It is essential that electrical power is available before the task is commenced.
 - a) Become familiar with the equipment and its operation.
 - b) Isolate system electrically.
 - c) Before attempting the procedure ensure that:
 - Mechanical handling equipment is available, if required, for handling refrigerant cylinders;
 - All personal protective equipment is available and being used correctly;
 - The recovery process is supervised at all times by a competent person;
 - Recovery equipment and cylinders conform to the appropriate standards.
 - d) Pump down refrigerant system, if possible.
 - e) If a vacuum is not possible, make a manifold so that refrigerant can be removed from various parts of the system.
 - f) Make sure that cylinder is situated on the scales before recovery takes place.
 - g) Start the recovery machine and operate in accordance with manufacturer's instructions.
 - h) Do not overfill cylinders. (No more than 80 % volume liquid charge).
 - i) Do not exceed the maximum working pressure of the cylinder, even temporarily.
 - j) When the cylinders have been filled correctly and the process completed, make sure that the cylinders and the equipment are removed from site promptly and all isolation valves on the equipment are closed off.
 - k) Recovered refrigerant shall not be charged into another refrigeration system unless it has been cleaned and checked.

15. Labelling

- Equipment shall be labelled stating that it has been de-commissioned and emptied of refrigerant.
- The label shall be dated and signed.
- Ensure that there are labels on the equipment stating the equipment contains flammable refrigerant.

16. Recovery

- When removing refrigerant from a system, either for servicing or decommissioning, it is recommended good practice that all refrigerants are removed safely.
- When transferring refrigerant into cylinders, ensure that only appropriate refrigerant recovery cylinders are employed.
- Ensure that the correct number of cylinders for holding the total system charge is available.
- All cylinders to be used are designated for the recovered refrigerant and labelled for that refrigerant (i.e. special cylinders for the recovery of refrigerant).
- Cylinders shall be complete with pressure relief valve and associated shut-off valves in good working order.
- Empty recovery cylinders are evacuated and, if possible, cooled before recovery occurs.
- The recovery equipment shall be in good working order with a set of instructions concerning the equipment that is at hand and shall be suitable for the recovery of the flammable refrigerant.
- If in doubt, the manufacturer should be consulted.
- In addition, a set of calibrated weighing scales shall be available and in good working order.
- Hoses shall be complete with leak-free disconnect couplings and in good condition.
- The recovered refrigerant shall be processed according to local legislation in the correct recovery cylinder, and the relevant waste transfer note arranged.
- Do not mix refrigerants in recovery units and especially not in cylinders.
- If compressors or compressor oils are to be removed, ensure that they have been evacuated to an acceptable level to make certain that flammable refrigerant does not remain within the lubricant.
- The compressor body shall not be heated by an open flame or other ignition sources to accelerate this process.
- When oil is drained from a system, it shall be carried out safely.
- This appliance is not intended for use by persons (including children) with reduced physical, sensory or mental capabilities, or lack of experience and knowledge, unless they have been given supervision or instruction concerning use of the appliance by a person responsible for their safety. Children should be supervised to ensure that they do not play with the appliance.
- When moving or relocating the dehumidifier, consult experienced service technicians for disconnection and reinstallation of the unit.
- Do not place any other electrical products or household belongings under the unit. Condensation dripping from the unit might get them wet, and may cause damage or malfunction of your property.
- To keep ventilation openings clear of obstruction.
- The appliance shall be stored in a well-ventilated area where the room size corresponds to the room area as specified for operation.
- The appliance shall be stored in a room without continuously operating open flames (for example: an operating gas appliance) and ignition sources (for example operating electric heater).
- Any person who is involved with working on or breaking into a refrigerant circuit should hold a current valid certificate from an industry-accredited assessment authority, which authorises their competence to handle refrigerants safely in accordance with an industry recognised assessment specification.

- Servicing shall only be performed as recommended by the equipment manufacturer.
- Maintenance and repair requiring the assistance of other skilled personnel shall be carried out by the person competent in the use of flammable refrigerants.
- The pipe-work shall be complied with national gas regulations.
- The maximum refrigerant charge amount is 0.45kg.
- The installation of pipe-work shall be kept to minimum.

If the refrigerant is flammable the air conditioning equipment shall have red, Pantone® Matching System (PMS) #185 marked service ports, pipes, hoses, and other devices through which the refrigerant is serviced. This colour shall be present at all service ports and where service puncturing or otherwise creating an opening from the refrigerant circuit to the atmosphere might be expected (e.g., process tubes). The colour mark shall extend at least 25 mm (1 inch) from the refrigerant servicing point and shall be replaced if removed

	<p>WARNING</p> <ul style="list-style-type: none"> • Do not use means to accelerate the defrosting process or to clean, other than those recommended by the manufacturer. • The appliance shall be stored in a room without continuously operating ignition sources (for example: open flames, an operating gas appliance or an operating electric heater). • Do not pierce or burn. • Be aware that refrigerants may not contain an odour.
	<p>VERTISSEMENT</p> <ul style="list-style-type: none"> • Ne pas utiliser de produits permettant d'accélérer le dégel ou de produits de nettoyage autres que ceux recommandés par le fabricant. • L'appareil doit être entreposé dans un endroit sans source d'allumage fonctionnant en continu (par exemple : flamme nue, appareil au gaz en marche ou radiateur électrique en marche). • Ne pas percer ni brûler. • Attention : les frigorigènes peuvent être inodores.

I.3 Explanation of symbol displayed on the unit.

The symbol consists of a red diamond with a flame inside, a yellow triangle with a flame inside, and the text 'A2L' to the right.	WARNING	<ul style="list-style-type: none">• This symbol shows that this appliance uses a flammable refrigerant.• If the flammable refrigerant is leaked and exposed to an external ignition source, there is a risk of fire.
An icon of a closed book.	CAUTION	<ul style="list-style-type: none">• This symbol shows that the operation manual should be read carefully.
An icon of an open book with a wrench and screwdriver crossed over it.	CAUTION	<ul style="list-style-type: none">• This symbol shows that a service personnel should be handling this equipment with reference to the installation manual.
An icon of an open book with an information symbol (a lowercase 'i' in a square) on the right page.	CAUTION	<ul style="list-style-type: none">• This symbol shows that information is available such as the operating manual or installation manual.

PRODUCT OVERVIEW

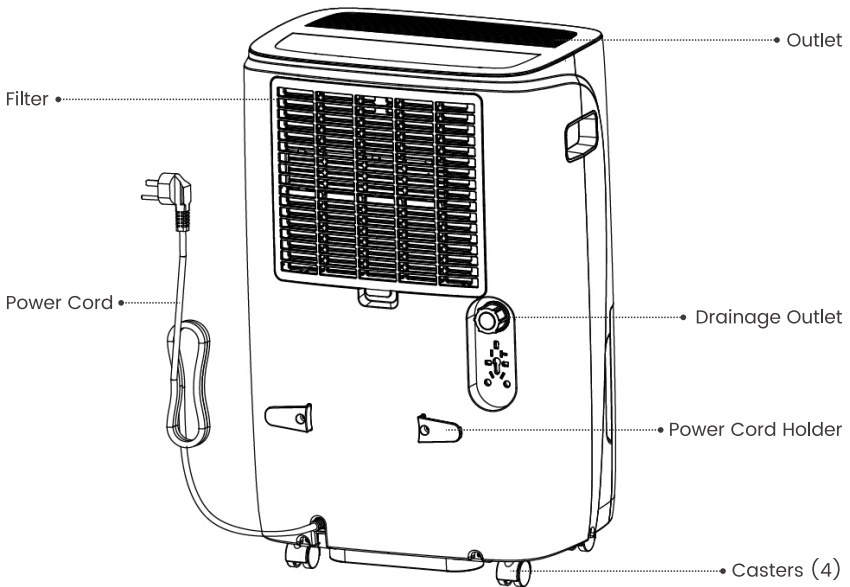
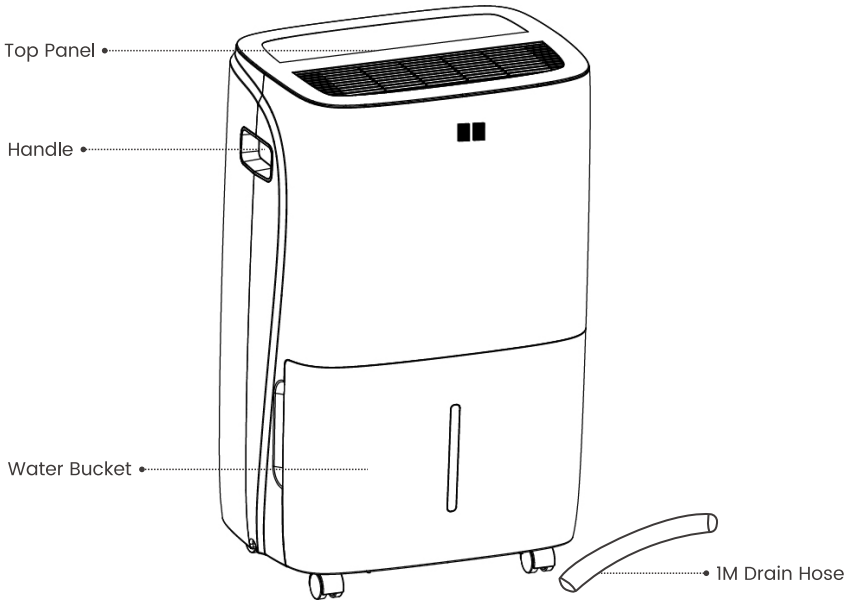

BEFORE FIRST USE

Positioning the Unit

- Do not force casters to move over the carpet.
- Do not move the unit with water in the bucket. The unit may tip over and water may spill.
- Do not use outdoors.
- This dehumidifier is intended for indoor residential applications only. This dehumidifier should not be used for commercial or industrial applications.
- Place the dehumidifier on a smooth, level floor strong enough to support the unit with a full bucket of water.
- Allow at least 8 inches of air space on all sides of the unit for good air circulation (at least 16 inches of air space on air outlet).
- Place the unit in an area where the temperature will not fall below 41 ° F. The coils can become covered with frost at temperatures below 41 ° F, which may reduce performance.
- Place the unit away from the clothes dryer, heater or radiator.
- Use the unit to prevent moisture damage anywhere books or valuables are stored.
- Use the unit to prevent moisture damage anywhere books or valuables are stored.

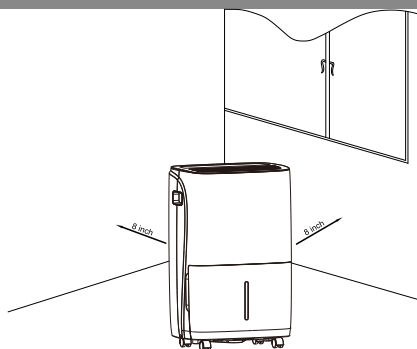

Using the Unit

- When first using the dehumidifier, operate the unit continuously for 24 hours. Make sure the plastic cover on the continuous drain hose outlet is installed properly so there are no leaks.
- This unit is designed to operate with a working environment between 41 ° F and 90 ° F, and between 35% to 80% relative humidity.
- If the unit is turned off and needs to be restarted, allow approximately three minutes for it to resume correct operation.
- Do not connect the dehumidifier to a multiple socket outlet, which is also being used for other electrical appliances.
- Select a suitable location, making sure you have easy access to an electrical outlet into an electrical socket.
- Plug the unit into an electrical socket outlet.
- Make sure the water bucket is correctly fitted otherwise the unit will not operate properly.

OPERATION INSTRUCTIONS

Control Panel

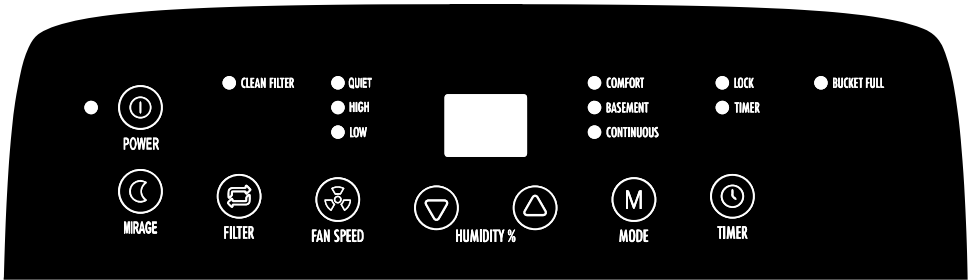

1. POWER

The Power display remains on during operation. In STANDBY mode, the display activates for 3 seconds before turning off, leaving only the Power indicator illuminated. The default operating mode is set to 40% RH at the quiet fan speed.

During auto mode or any other operating mode, When turn off the unit it will enter STANDBY mode. When resumed from STANDBY, the unit will return to its previous mode, fan speed, and humidity settings.

2. MIRAGE

A backlit display on the front of the dehumidifier shows the current room humidity level, making it easy to read from across the room. Press the "MIRAGE" button to turn on the mode; press it again to turn it off.

3. FILTER

Reset the "Filter" button:

After the dehumidifier starts up and runs for 250 hrs. The indicator light for cleaning the filter will be on. Refer to CLEANING & MAINTENANCE section for filter cleaning instructions. After the filter has been cleaned, press the FILTER button to remove the indicator light and reset the timer.

4. FAN SPEED

Press "FAN SPEED" button as follows:

When the fan speed needs to be adjusted, press the fan speed button to adjust the Quiet, Low and High fan speed. When the corresponding indicator light is on, the current speed has been set.

5. "UP" and "DOWN"

Press "UP" and "DOWN" to enter the Auto dehumidification operation. The humidity is set to 35%-- 80%, with 5%RH added and decreased each time.

6. MODE

Press the "MODE" button to cycle through the following preset options: Comfort Space (50% RH), Basement (45% RH) and Continuous. The indicator light for the selected mode will be on.

7. TIMER

OPERATION INSTRUCTIONS

Press "Timer" button to set the timer up to 24 hours.

- (1) In STANDBY mode, press the Timer button to set the startup function. The Timer light will be on, and the display will initially display "0.5". Press "UP" and "DOWN" to adjust the time. The timer indicator is on when the timer function is active. Press the Timer button again to cancel the timing function.
- (2) In operating mode, press the Timer button to set the shutdown function. The Timer light will be on, and the display will initially display "0.5". Press "UP" and "DOWN" to adjust the time.
- (3) The range of time setting is 0.5h-24h. Press "UP" and "DOWN" to adjust $\pm 0.5h$ between 0.5h-10h, while $\pm 1h$ between 10h-24h.



The indicator shows humidity and time.

1. Humidity Level : It displays different values based on the environment or settings: the current room humidity, the selected target humidity, or a fixed value of "20" or "90" if the ambient humidity falls below 20% or exceeds 90%, respectively.

2. Time Display: When programming the unit's automatic turn-on and turn-off timer, the indicator switches to display the number of hours set for the schedule.

Other Features

Bucket Full Light

When the water bucket is full, the unit will shut off automatically, make a beeping sound and the BUCKET FULL indicator will light up. The dehumidifier will not run again until the bucket is emptied and properly placed back inside the unit.

Auto Shut-Off

The dehumidifier shuts off when the bucket is full, or when the bucket is removed or is not positioned correctly. The fan motor will continue to run for 3 minutes. Wait 3 minutes before attempting to restart operation. This is to protect the unit. The unit will often resume operation automatically after this 3-minute period.

Auto-Restart

If the unit turns off unexpectedly due to a power outage, it will automatically restart and resume its previous function settings when the power resumes.

Child Lock Function

Press and hold the Timer button for over 3 seconds to activate the child lock. The lock indicator light will turn on, and all other buttons will be disabled. Press and hold the Timer button again for over 3 seconds to deactivate the child lock.

CLEANING & MAINTENANCE

⚠ CAUTION – Turn the dehumidifier off and remove the plug from the wall outlet before cleaning.

Draining the Collected Water

Option 1: Water Bucket

When the water Bucket is full, the bucket full indicator light will turn on, the operation will stop automatically and the buzzer will sound to alert the user, that the water needs to be emptied from the bucket.

1. Lightly press on the sides of the bucket with both hands and pull the bucket out gently.
2. Discard the collected water.

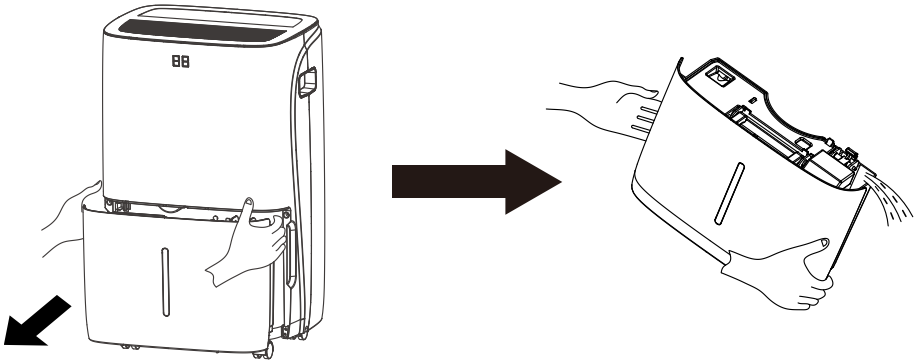

NOTE: Do not remove the float from the water bucket. The water full sensor will no longer be able to detect the water level correctly without the float and water may leak from the water bucket.

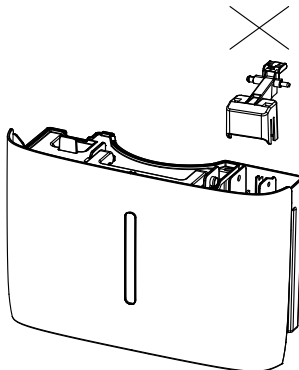

CLEANING & MAINTENANCE

3. When replacing the water bucket, press the bucket firmly into place with both hands. If the bucket is not positioned properly, the "BUCKET FULL" indicator will still be on, and the dehumidifier will not operate.

NOTE:

Placing the dehumidifier on an uneven surface or installing the hose improperly may cause the bucket to fill with water and trigger a unit shut-off. If this happens, empty the bucket and then check the unit's location and hose installation to ensure they are correct. The bucket must be in place and securely seated for the dehumidifier to operate.

Option 2: Continuous drainage

- (1) Unscrew the drainage outlet cover on the back of the machine.
- (2) Insert the drain hose (included) and make sure the hose is securely attached to prevent leaks. The dehumidifier will then continuously drain water.

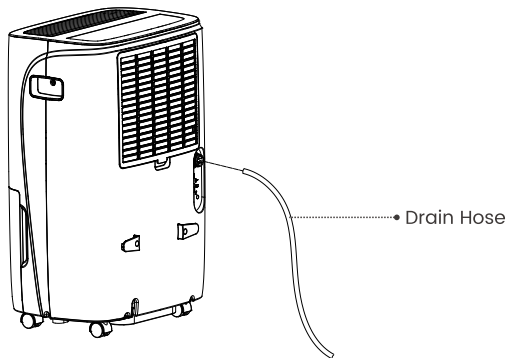

The drain hose must be installed straight and without kinks. Ensure the hose is not sharply bent, twisted, or elevated above the water outlet. The path of the hose must remain clear and unobstructed. Do not use extension tubes or replace the provided hose with a different type.

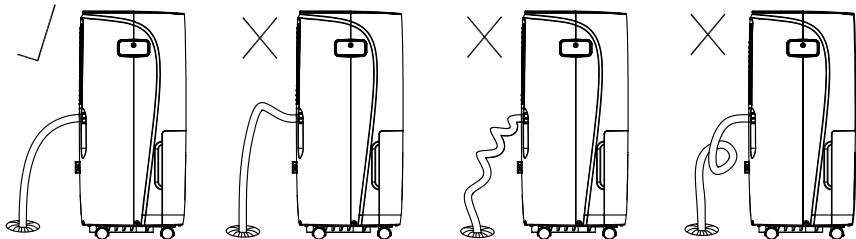

CLEANING & MAINTENANCE

Cleaning the Dehumidifier

To Clean the Body

Wipe it with a soft damp cloth.

To Clean the Water Bucket

Clean the water bucket every few weeks with cold or lukewarm water to prevent mold and bacteria. Avoid all detergents, solvents, and abrasive tools to prevent damage and leakage. Rinse by swishing water inside, then empty and rinse. Do not dishwasher-clean, and always replace the bucket securely after cleaning.

To Clean the Air Filter

(Remove the filter every two weeks based on normal operating conditions.)

1. Take out the filter frame first and wash with water.

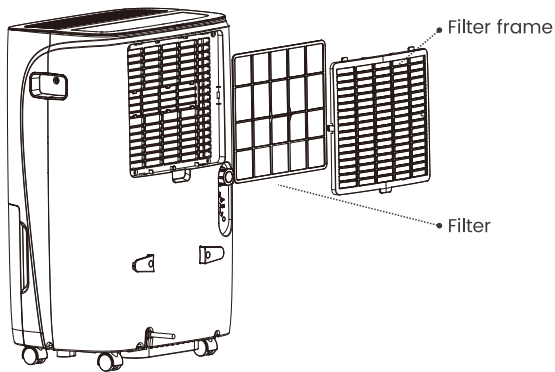

2. Clean the filter

Use a vacuum cleaner to gently absorb the dust on the surface of the filter. If the filter is very dirty, wipe it with warm water and a soft cleaner and dry it completely.

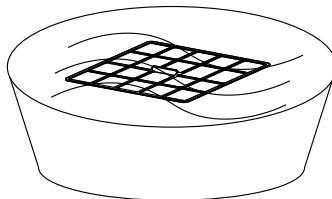

CLEANING & MAINTENANCE

3. Attach the filter

Insert the filter and the filter frame back on correctly.

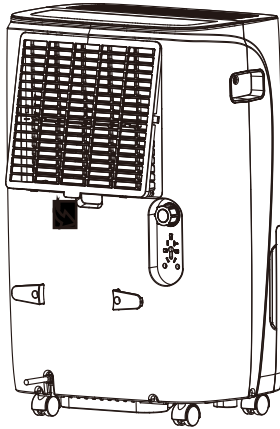

⚠ CAUTION : DO NOT operate the dehumidifier without a filter because dirt and lint will clog it and reduce performance. Unit should be turned off and unplugged to clean filter.

Storing the Dehumidifier

WHEN NOT USING THE UNIT FOR LONG TIME PERIODS

- After turning off the unit, wait one day before emptying the bucket.
- Clean the main unit, water bucket and air filter.
- Wrap the cord around the power cord holder.
- Cover the unit with a plastic bag.
- Store the unit upright in a dry, well-ventilated place.

TROUBLESHOOTING

BEFORE YOU CALL FOR SERVICE

IF THE APPLIANCE FAILS TO OPERATE:

- A) Check to make sure that the dehumidifier is plugged in securely. If it is not, remove the plug from the outlet, wait 10 seconds and plug it in again securely.
- B) Check for a blown circuit fuse or a tripped main circuit breaker. If these seem to be operating properly, test the outlet with another appliance.

IF NONE OF THE ABOVE SOLVES THE PROBLEM, CONTACT A QUALIFIED TECHNICIAN. DO NOT TRY TO ADJUST OR REPAIR THE APPLIANCE YOURSELF.

Troubleshoot your problem by using the chart below. If the dehumidifier still does not work properly, contact our customer service center or the nearest authorized service center. Customers must never troubleshoot internal components

Problem	Possible Cause	Solution
The unit doesn't operate	Has the power cord been disconnected?	Plug the power cord into the outlet.
	Is the bucket full indication lamp blinking? (The bucket is full or in a wrong position.)	Empty the water in the drainage bucket and then reposition the bucket.
	Is the temperature of the room above 95°F (35°C) or below 44.6°F (7°C)?	The protection device is activated and the unit cannot be started.
The dehumidifying function doesn't work	Is the air filter clogged?	Clean the air filter as instructed under "Cleaning the dehumidifier".
	Is the intake duct or discharge duct obstructed?	Remove the obstruction from the discharge duct or intake duct.
No air is discharged	Is the air filter clogged?	Clean the air filter as instructed under "Cleaning the dehumidifier".

TROUBLESHOOTING

Problem	Possible Cause	Solution
Operation is noisy	Is the unit tilted or unsteady?	Move the unit to a stable, sturdy location.
	Is the air filter clogged?	Clean the air filter as instructed under "Cleaning the dehumidifier".
"E1" Error Code	Abnormal exhaust pipe temperature sensor	There may be an issue with the exhaust pipe temperature sensor and related circuit. Contact Customer Service at 855-855-0294.
"E2" Error Code	Coil temperature sensor abnormal	There may be an issue with the coil temperature sensor and related circuit. Contact Customer Service at 855-855-0294.
"E3" Error Code	Humidity sensor anomaly	There may be an issue with the PCB or the related circuit of the display panel. Contact Customer Service at 855-855-0294.
"E4" Error Code	Connecting line fault	There may be an issue with the display panel or the related circuit of the display panel. Contact Customer Service at 855-855-0294.
"E5" Error Code	Detection line fault	There may be a problem with the wiring. Contact Customer Service at 855-855-0294.
"EH" Error Code	Humidity sensor anomaly	There may be a problem with the humidity sensor related circuit. Contact Customer Service at 855-855-0294.

DISPOSAL

WARNING: Releasing refrigerant into atmosphere is strictly forbidden!



Do not dispose of electrical appliances as unsorted municipal waste, use separate collection facilities. Contact your local government for information regarding the collection systems available. If electrical appliances are disposed of in landfills or dumps, hazardous substances can leak into the groundwater and get into the food chain, damaging your health and well-being.

ROWAN ELECTRIC APPLIANCE LLC

8:30am-5:30pm P.S.T.
Monday to Friday