

Item#	Qty	Description	MATERIAL
1	2	TOP ASSEMBLY	WOOD
2	5	DRAWER ASSEMBLY	WOOD/METAL
3	10	FELT PAD	FABRIC
4	5	RIGHT CABINET GLIDE	METAL, PLASTIC
5	5	LEFT CABINET GLIDE	METAL, PLASTIC
6	1	**MITERED BASESTRIP**	WOOD
7	1	**BOTTOM MOULDING**	WOOD
8	2	SIDE BASESTRIP	WOOD
9	1	TIPPING RESTRAINT	PLASTIC
10	10	KNOB	METAL
11	1	**BASESTRIP ASSEMBLY**	WOOD

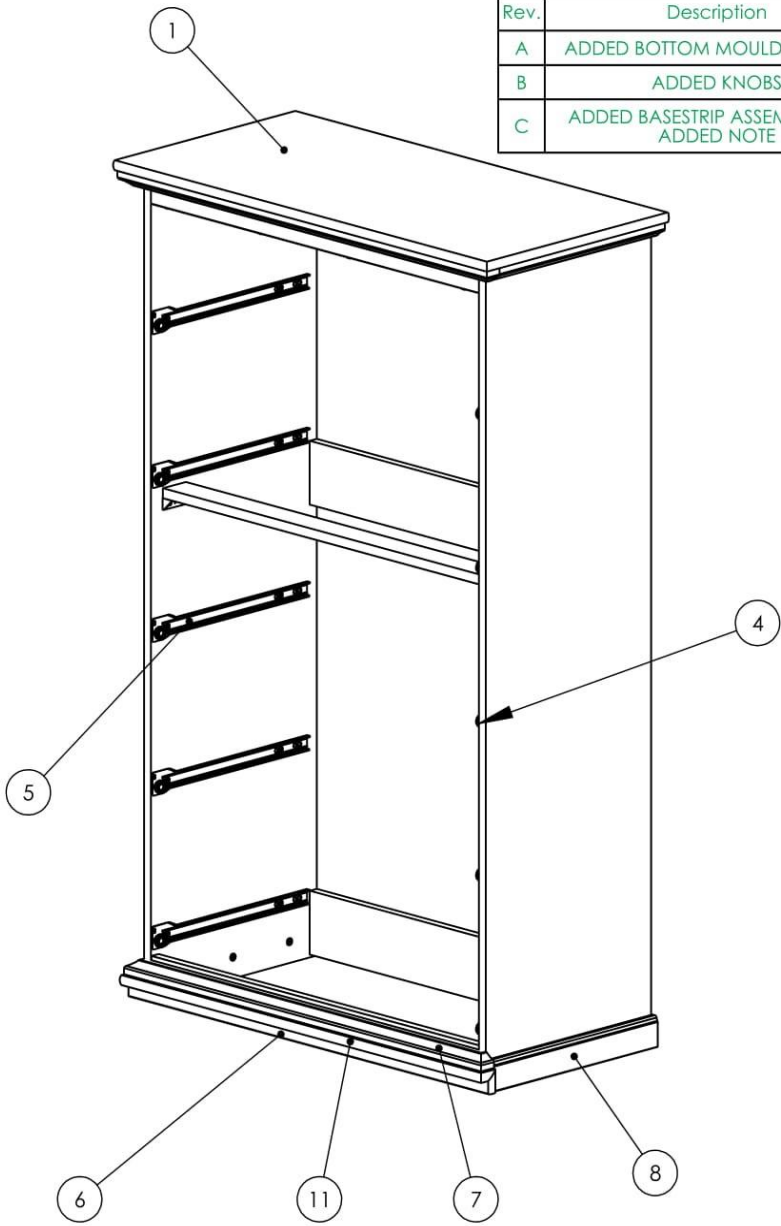

Scale: 1:12		TOLERANCES ARE: METRIC.....+.5 / -.5mm DECIMAL.....0 / -.005" FRACTIONAL.....+0 / -1/32" (UNLESS OTHERWISE SPECIFIED)
Desc: Chest		
Rev.	Description	Cad/Eng
A	ADDED BOTTOM MOULDING NOTE	BJB
B	ADDED KNOBS	TH
C	ADDED BASESTRIP ASSEMBLY AND ADDED NOTE	TH/DK

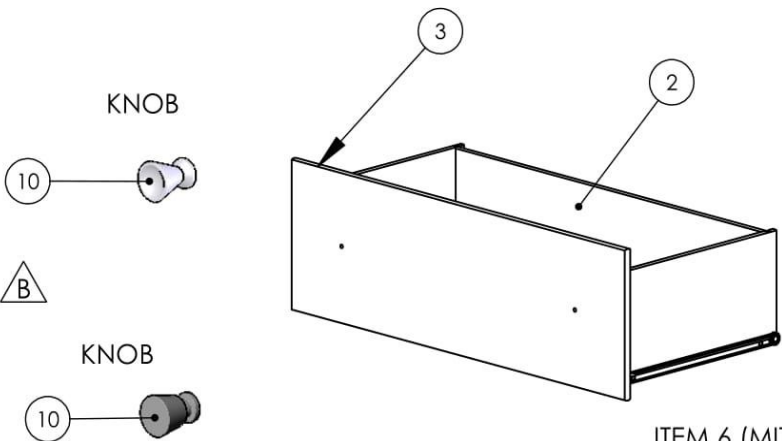

ITEM 6 (MITERED BASESTRIP)
REPLACED BY
ITEM 11 (BASESTRIP ASSEMBLY)



ITEM 7 (BOTTOM MOULDING)
REPLACED BY
ITEM 11 (BASESTRIP ASSEMBLY)