

SMART CURTAIN

USER GUIDE



CONTENTS

A	INSTALLATION	
	A-1. Preparation	1
	A-2. Accessories	2-3
	A-3. Adjust Curtain Rod	4-7
	A-4. Outside Mount	8-11
	A-5. Inside Mount	12-15
	A-6. Installation Of Double Tracks	16-20
	A-7. Installation Of Motor	21
	A-8. Take Down The Track	22
	A-9. Disassembly Of Motor	23

B	PARAMETERS	
	B-1. Motor	24-25
	B-2. Remote Control	
	Install The Battery	26
	Parameters	27-28

C	APP CONTROL	29
----------	--------------------	----

D	REMOTE CONTROL PROGRAMMING	
	D-1. Enter Setting Mode	30
	D-2. Clock Setting	31
	D-3. Timing Setting	32-35
	D-4. Motor Programming	36-41

A. INSTALLATION

A-1 PREPARATION



* Drilling hole size 6mm
Recommended size of drill bit: 15/64"

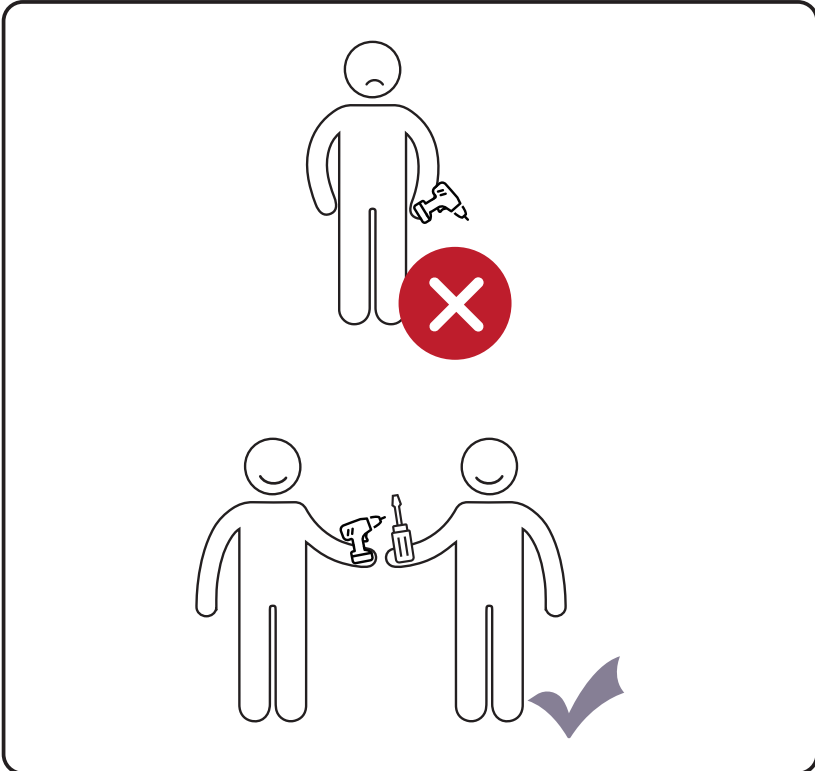

A-2 ACCESSORIES

1 Regular Version

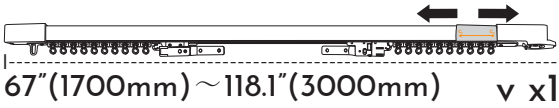

2 Extended Version

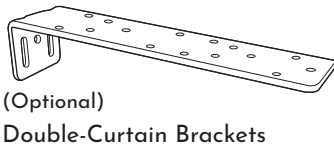
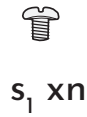
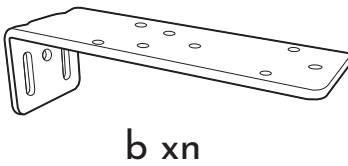
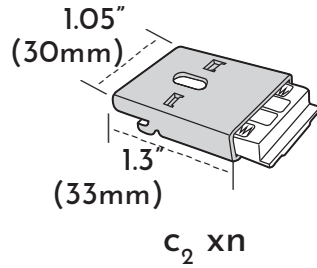
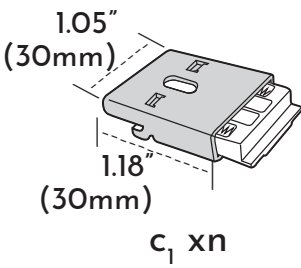
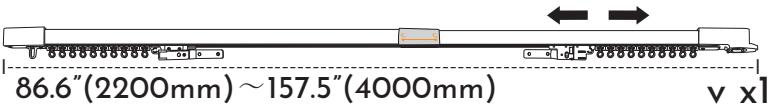

b₁ xn





j x1

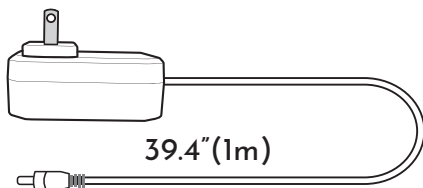

39.4"(1m)

g x1

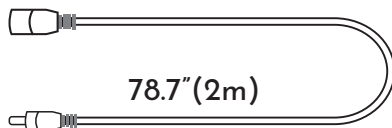

78.7"(2m)

w x1

VALANCE (OPTIONAL):



h xn

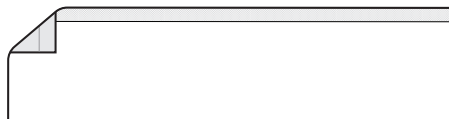

i x1

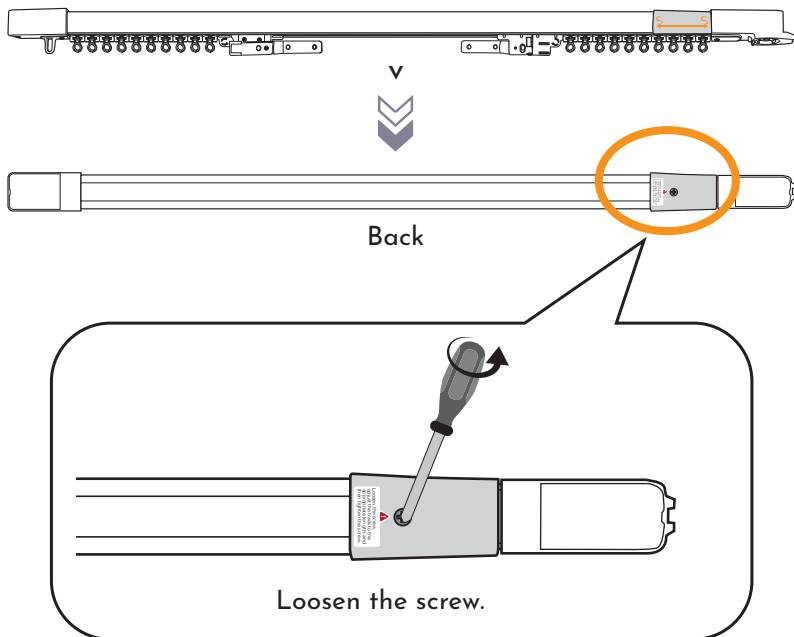
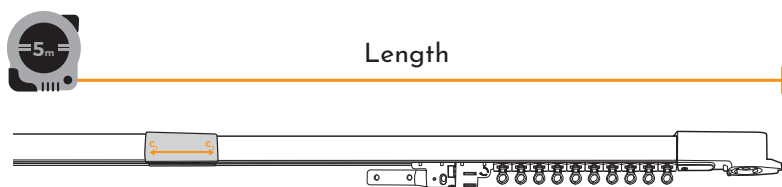
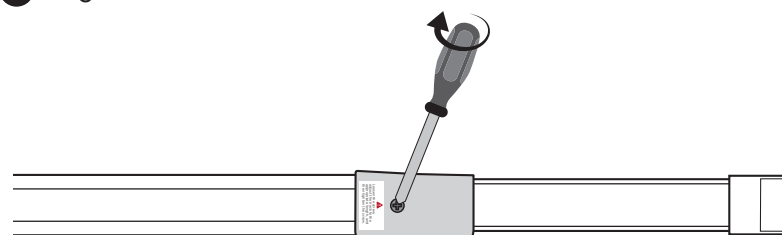

p x2

A-3 ADJUST CURTAIN ROD**1****2** Stretch to your desired length.**3** Tighten the screw.

4 Count hook "A"

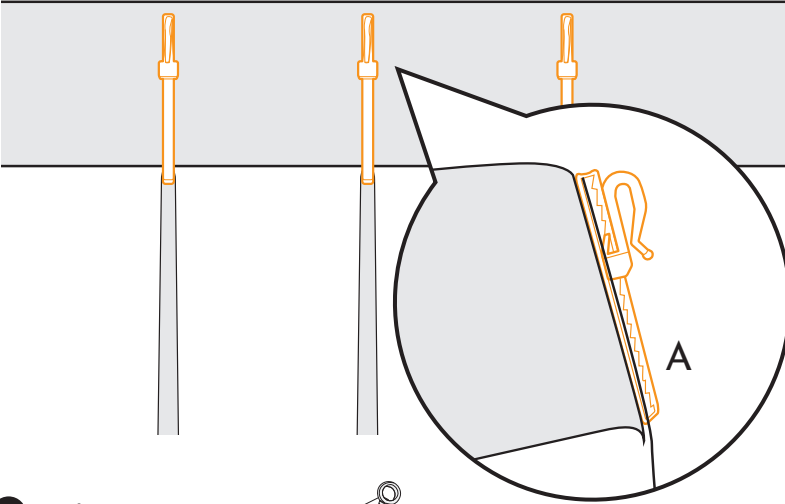

Back of L

5 Take out extra accessory "B" .

1. The end of track without motor:

Quantity of "B"  = Quantity "A"  minus 5

2. The end of track with motor:

Quantity of "B"  = Quantity "A"  minus 4

3. Skip this step if you don't need to take out extra B

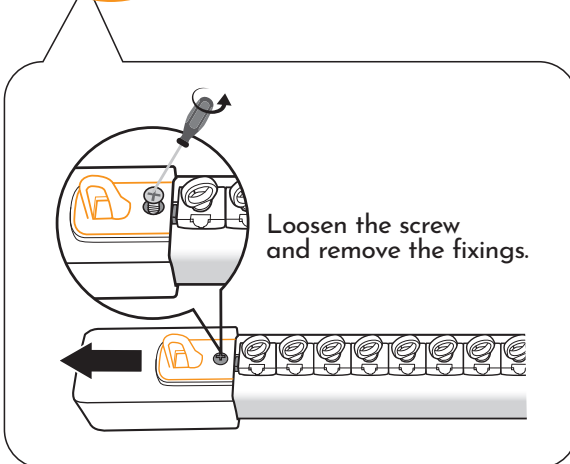
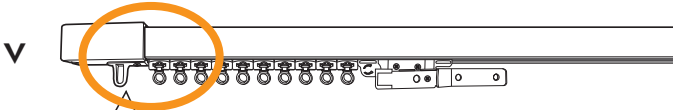

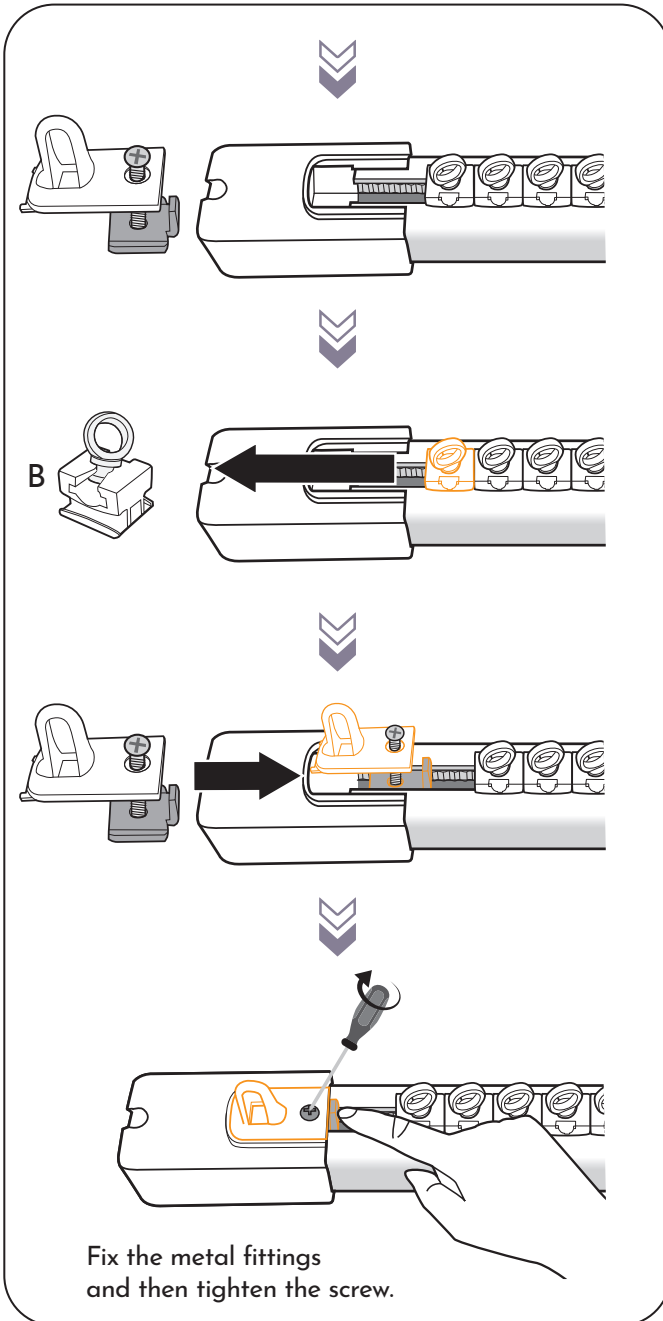

Repeat the steps above to take down extra "B" on the other end of the track.

6



7

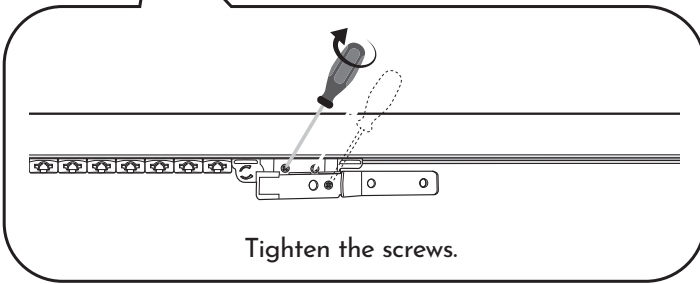

8

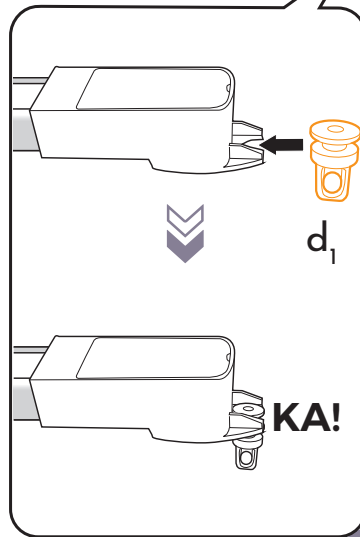
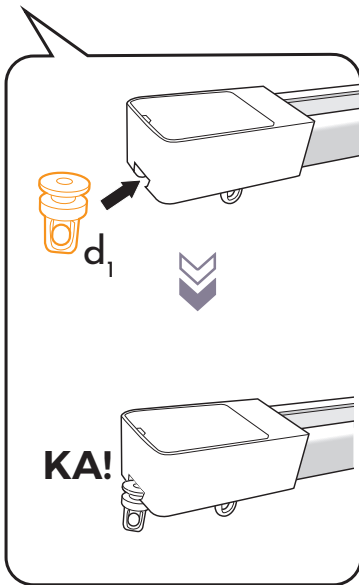

A-4 OUTSIDE MOUNT

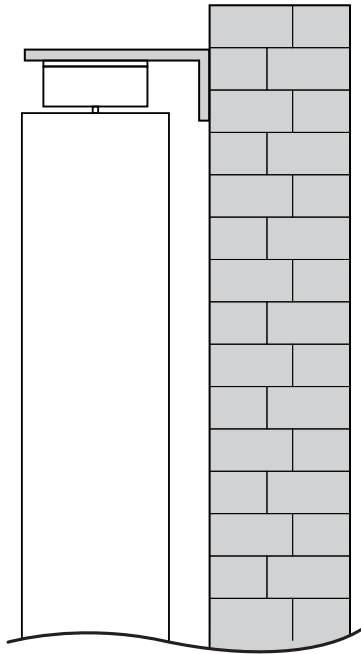
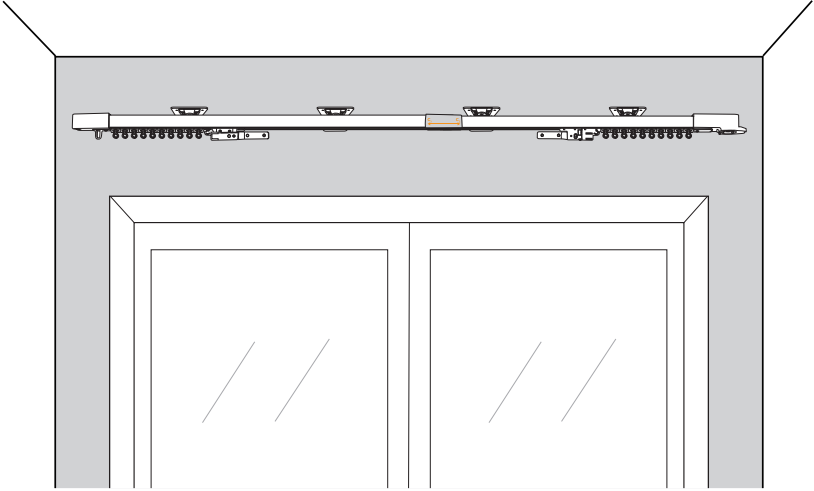

* The Side View

1

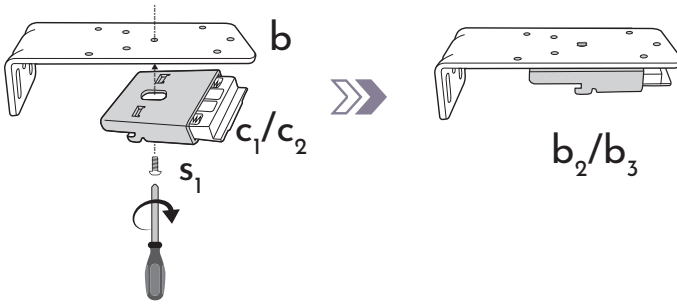

2

Stick the tape on the wall horizontally and leave 10" of space on both sides.

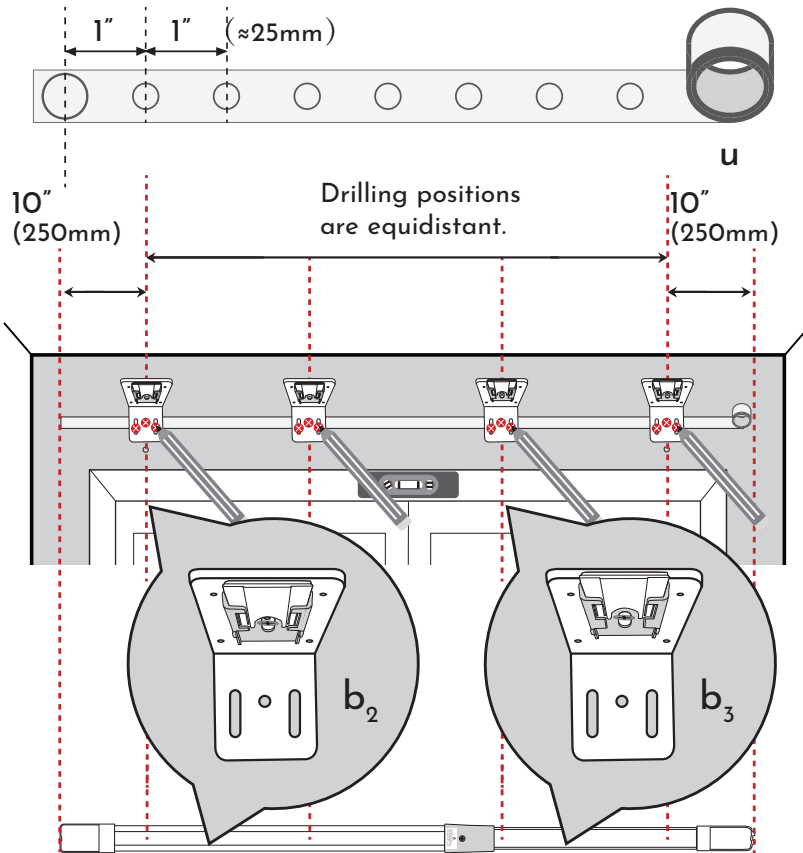

b_2 is used to clamp the wider part of the track.
 b_3 is used to clamp the narrower part of the track.

3 Drill holes & install mounting brackets.

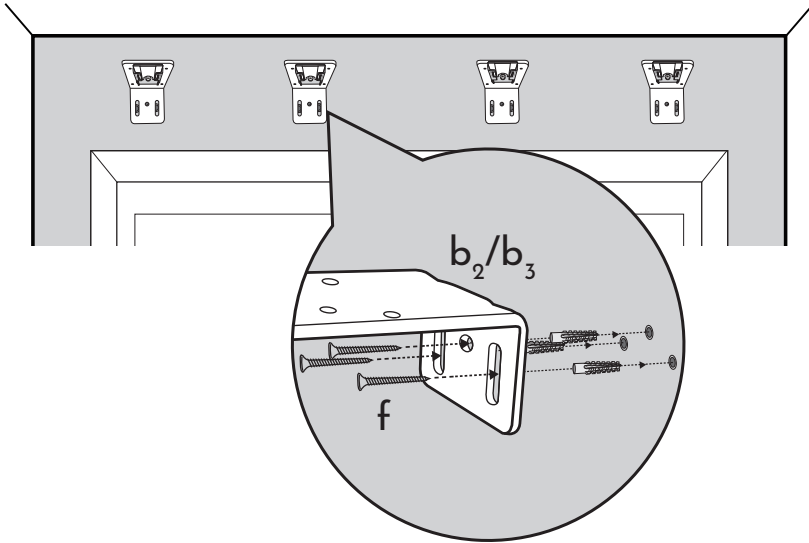

4 Install the track.

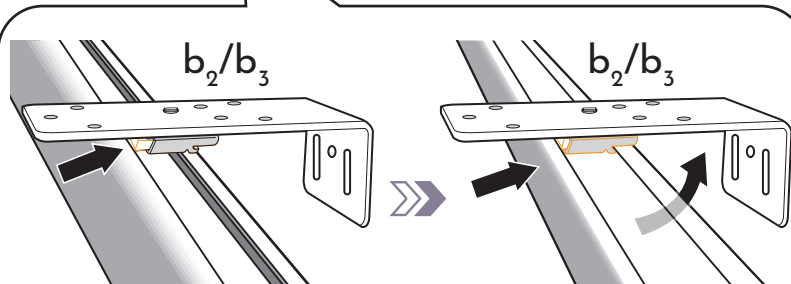
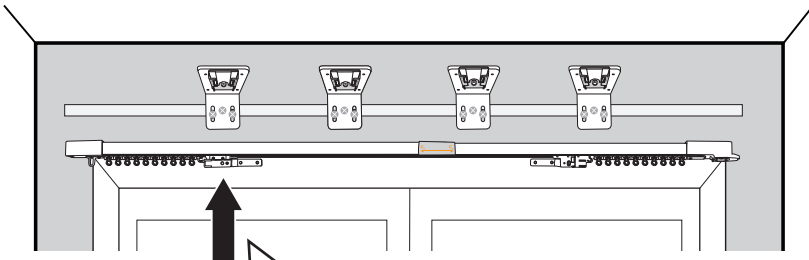

Slightly incline the track and put the white plastic inside the groove of the track.

Push the track inwards until the metal bracket is stuck inside the track.

5 Install valance brackets.

*Please skip this step if valance is not ordered.

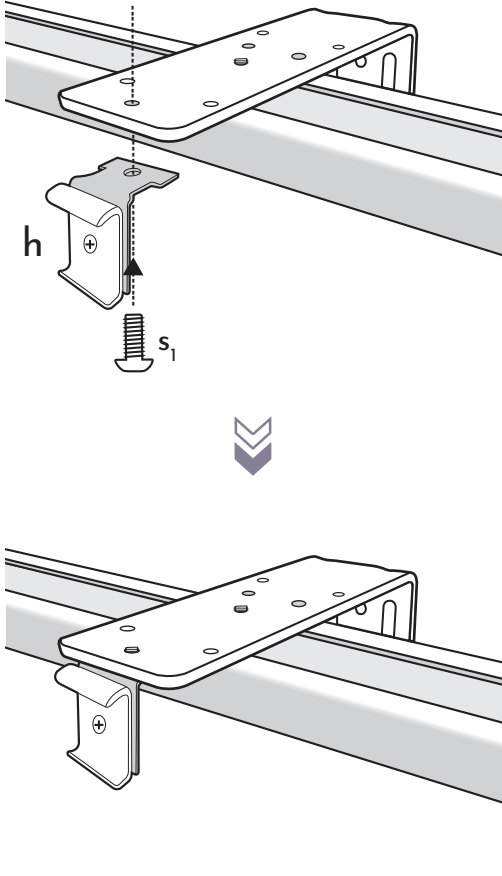

A-5 INSIDE MOUNT

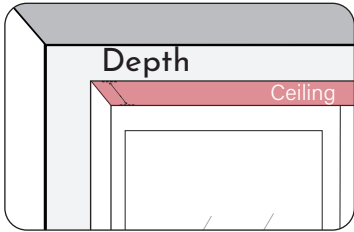
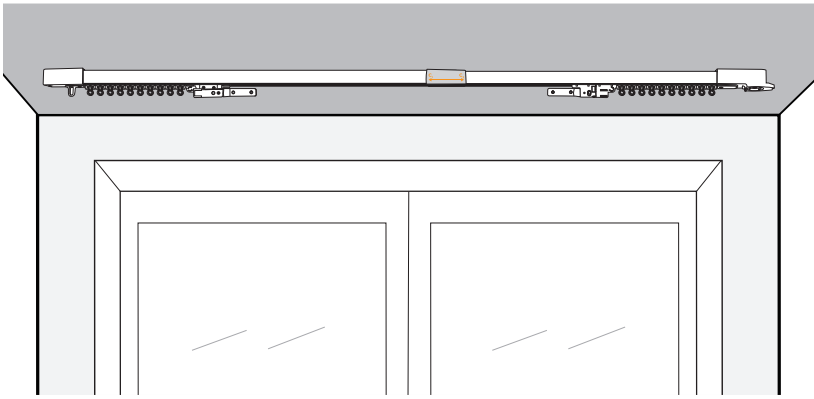

or

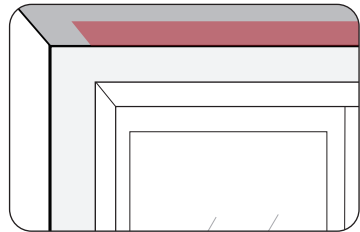

Depth $\geq 6"$ (150mm)

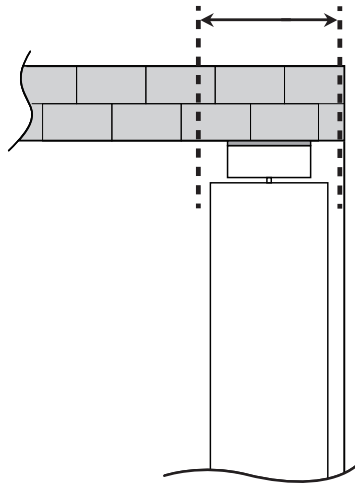

* The Side View

- 1 Stick the tape on the wall horizontally and leave 10" of space on both sides.

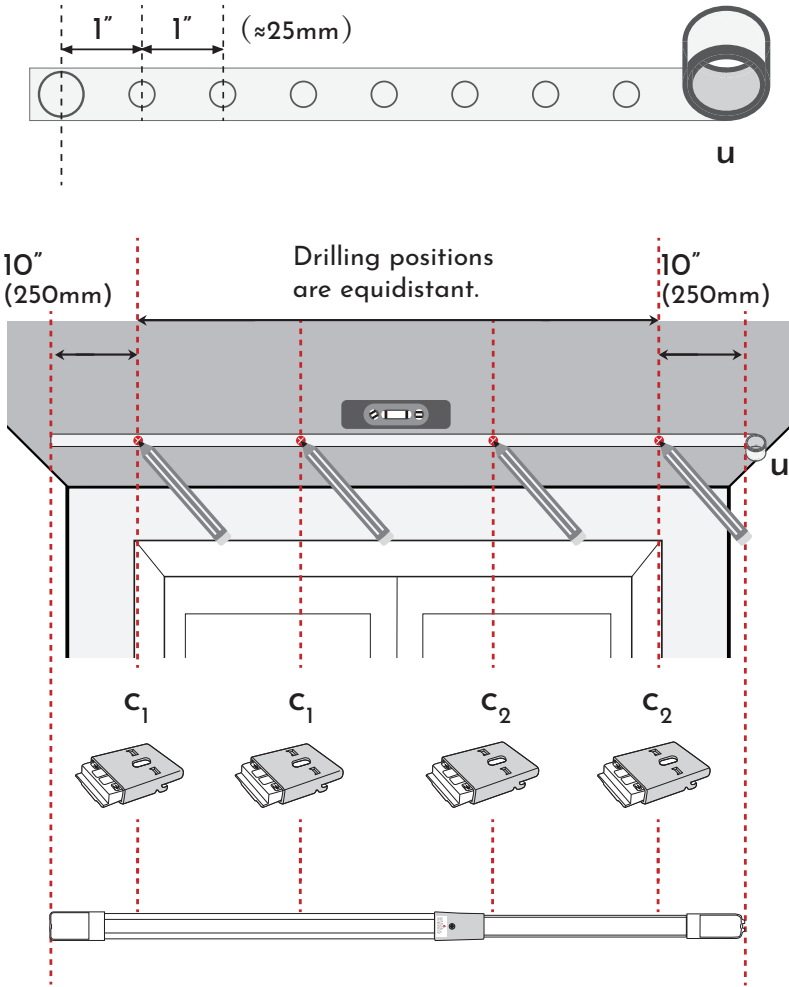

- C₁ is used to clamp the wider part of the track.
C₂ is used to clamp the narrower part of the track.

2 Drill holes & install mounting brackets

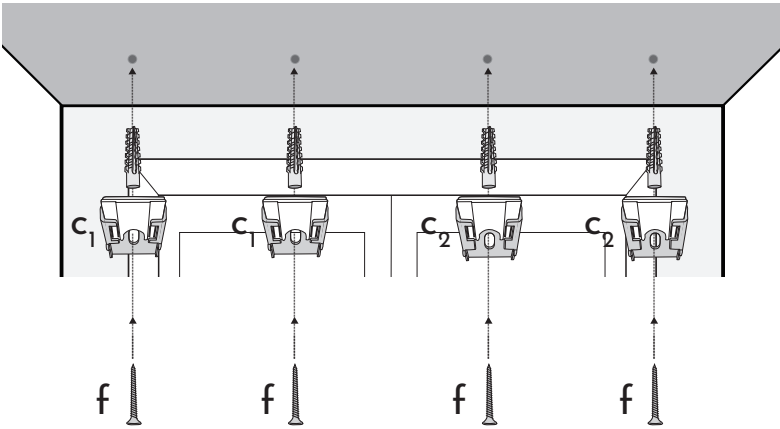

3 Install the track.

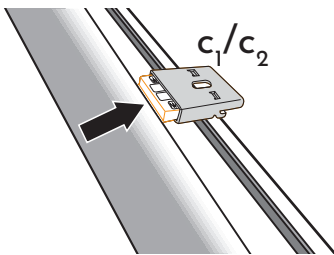
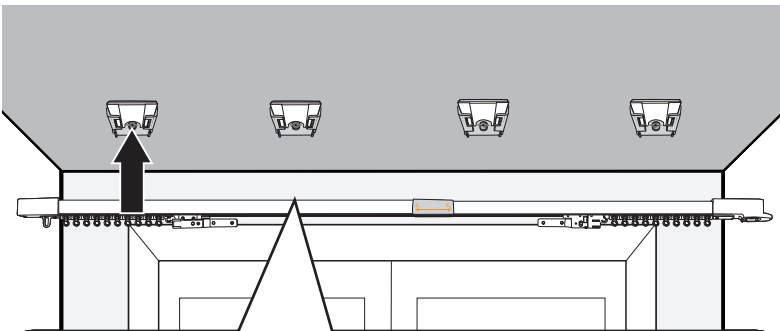

Slightly incline the track and put the white plastic inside the groove of the track.

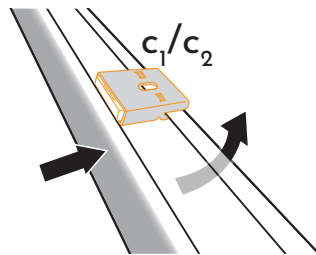

Push the track inwards until the metal bracket is stuck inside the track.

4 Install valance brackets.

*Please skip this step if valance is not ordered.

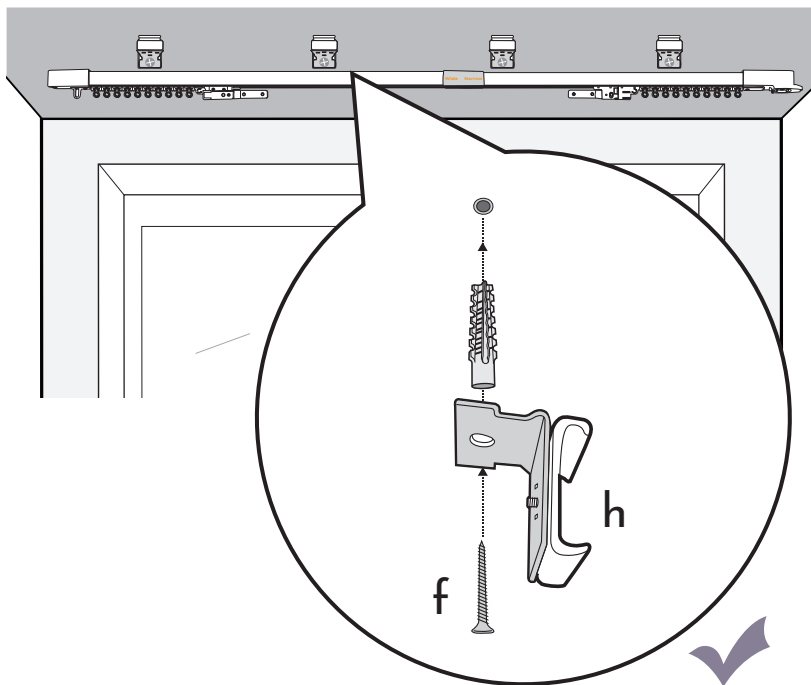

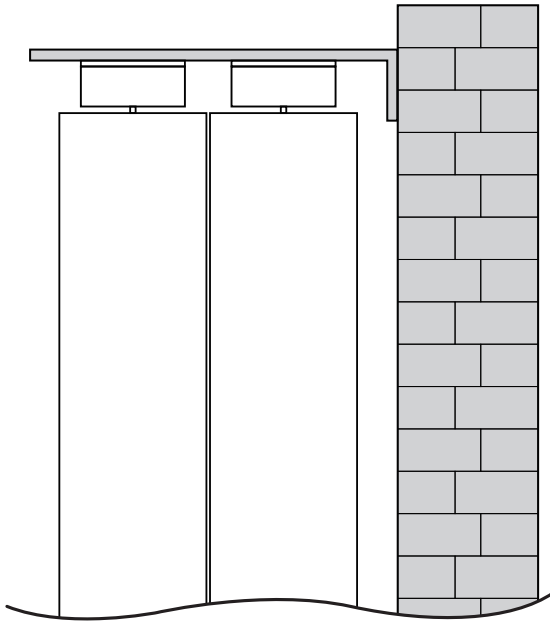
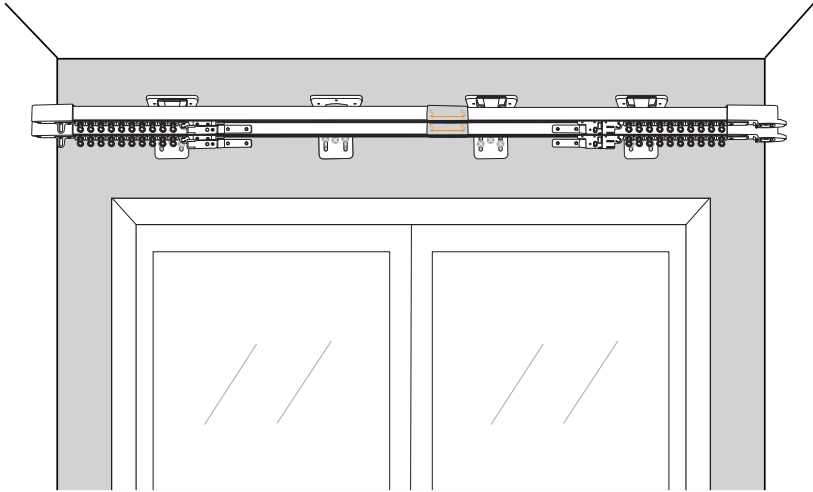
A-6 INSTALLATION OF DOUBLE TRACKS

* The Side View

1

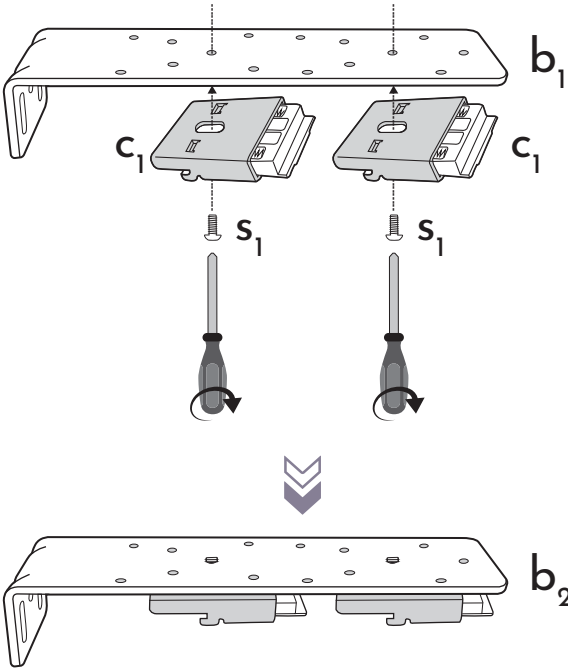

2

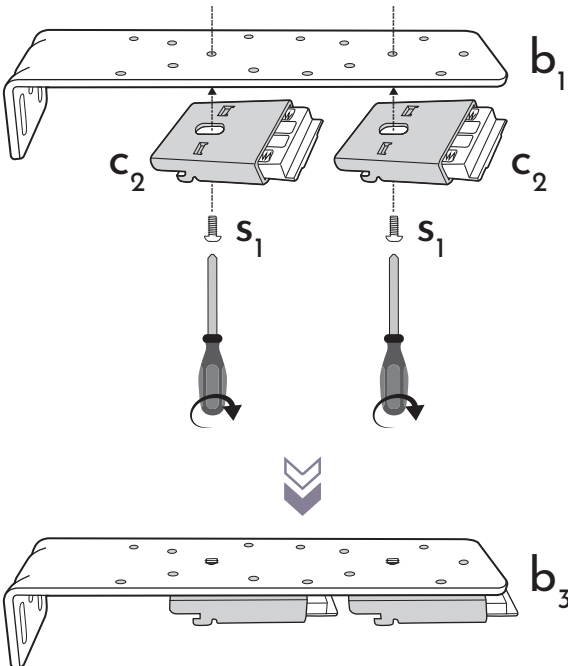

- 3 Stick the tape on the wall horizontally and leave 10" of space on both sides.

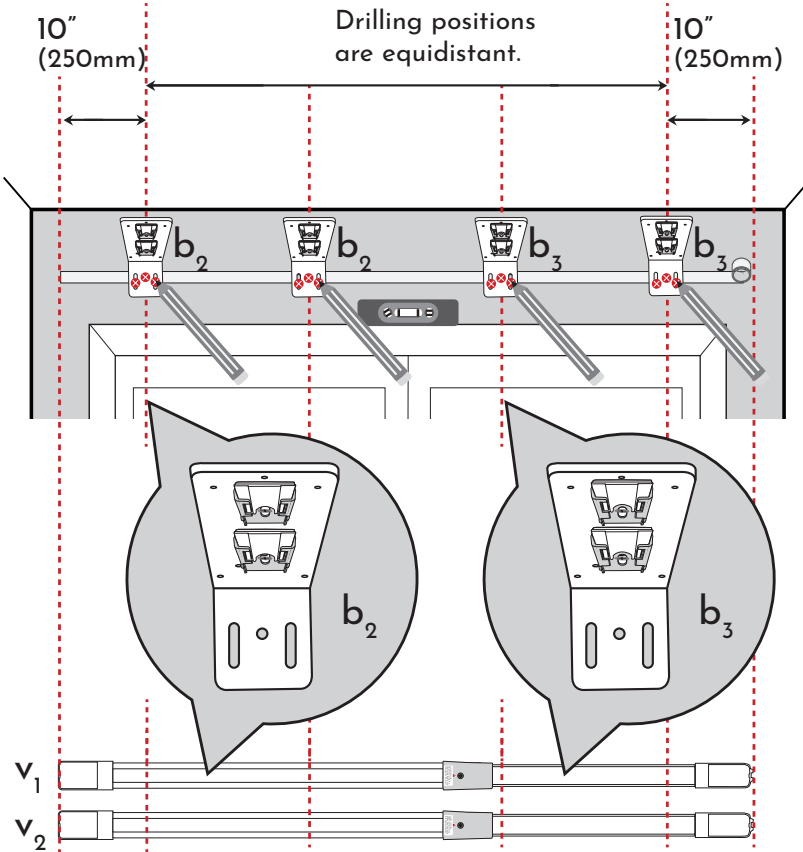
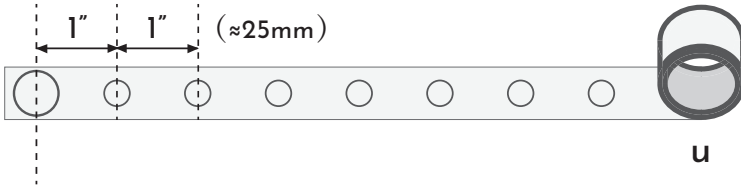

b_2 is used to clamp the wider part of the track.
 b_3 is used to clamp the narrower part of the track.

- 4 Drill holes & install mounting brackets.

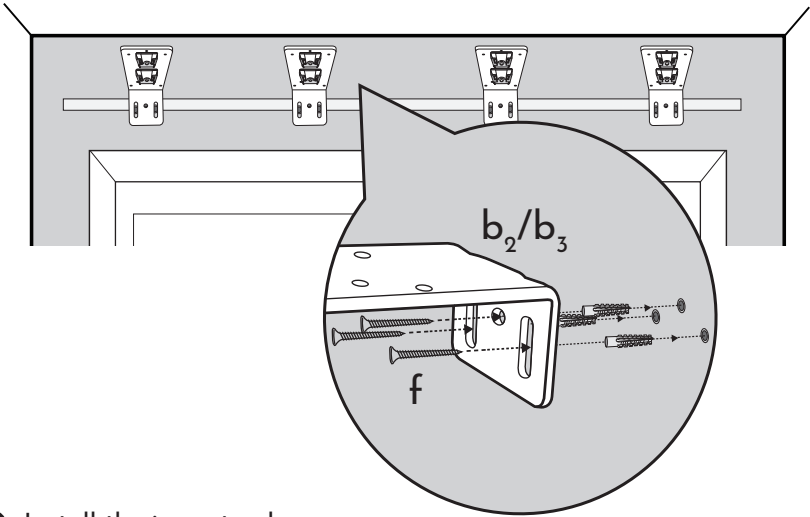

- 5 Install the inner track.

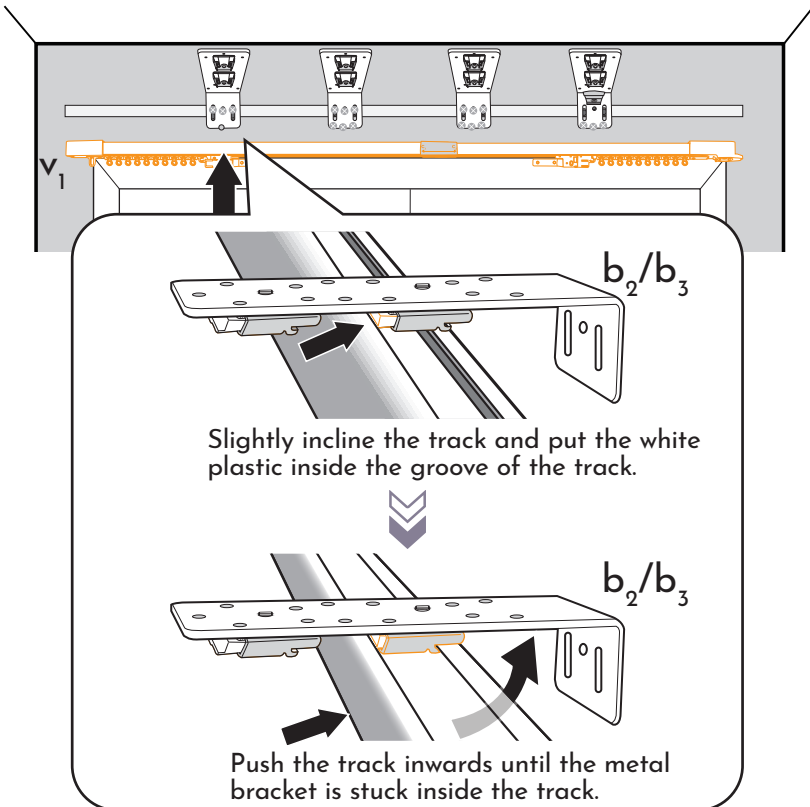

6 Install the outer track.

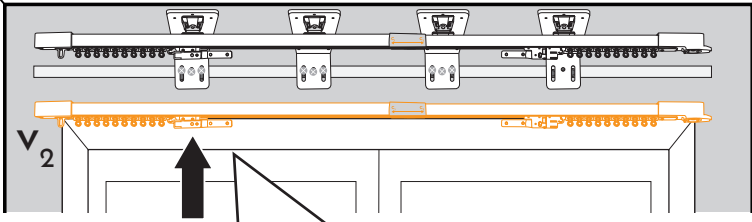

Slightly incline the track and put the white plastic inside the groove of the track.

Push the track inwards until the metal bracket is stuck inside the track.

7 Install valance brackets.
*Please skip this step if valance is not ordered.

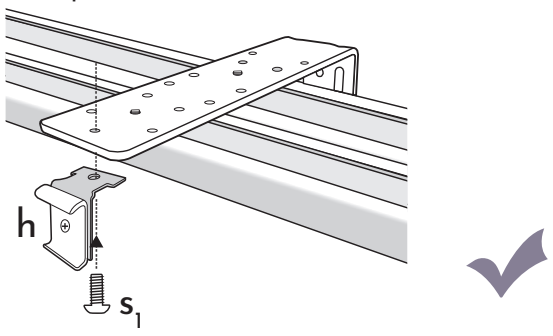

A-7 INSTALLATION OF MOTOR

1

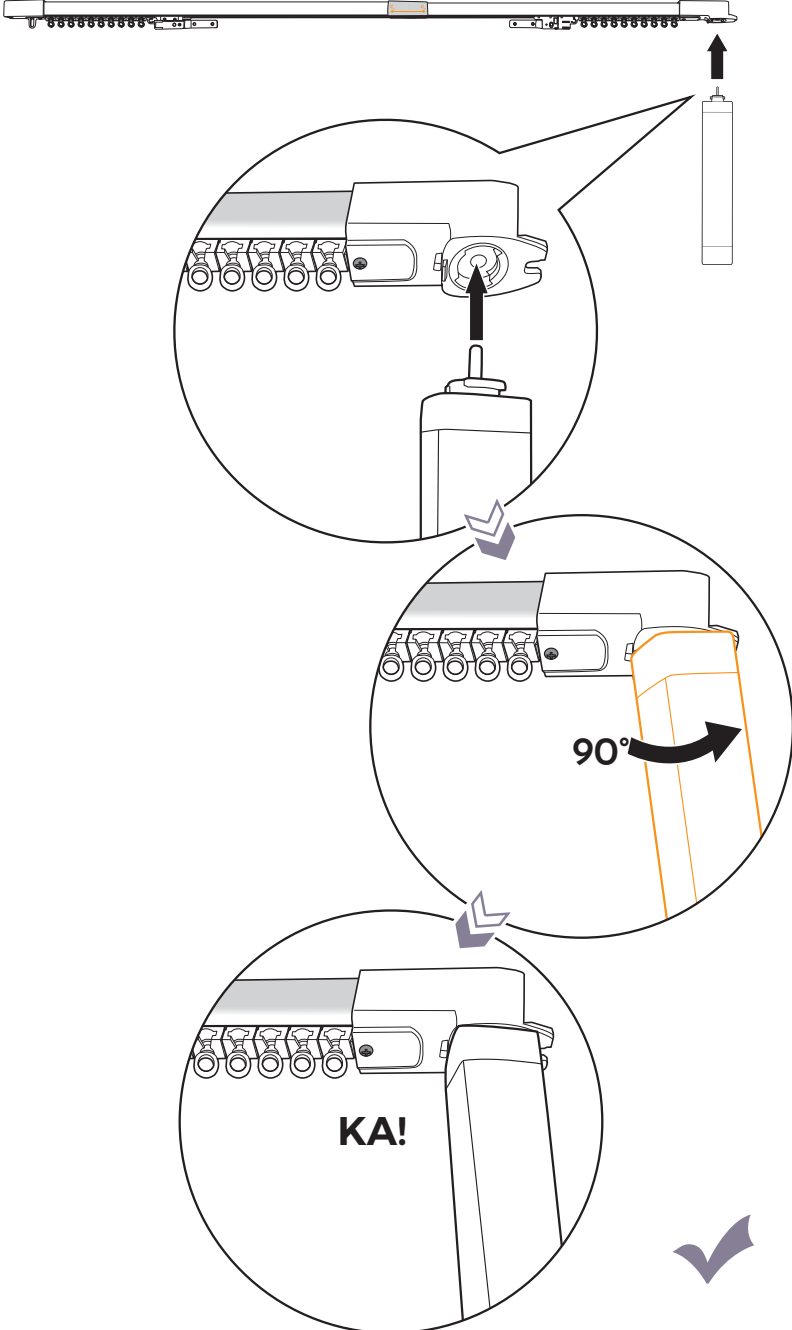

A-8 TAKE DOWN THE TRACK

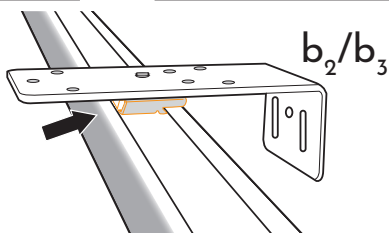
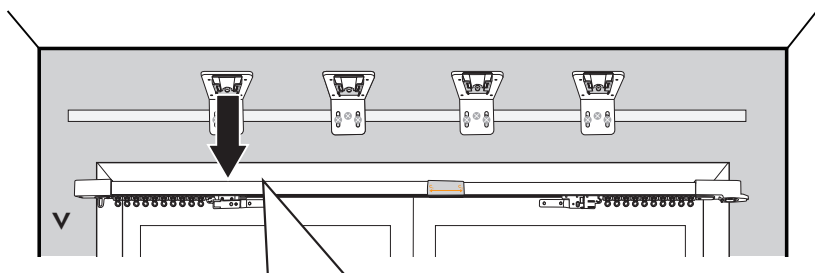

Push the track inwards.

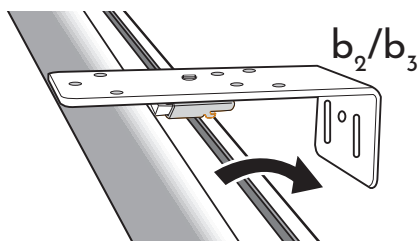

Incline the track until it is not stuck inside the brackets.

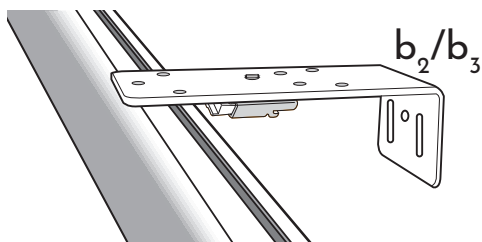

Take the track down.



A-9 DISASSEMBLY OF MOTOR



Please skip this step unless you want to take the motor down.

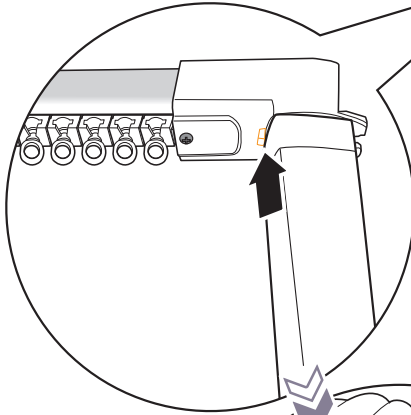
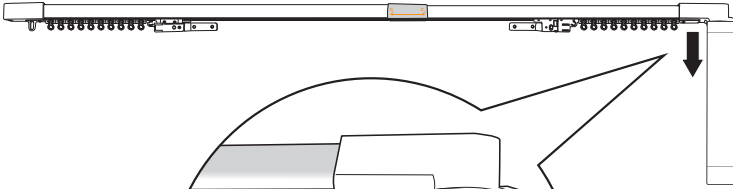

Hold the white plastic
and rotate the motor
by 90 degrees.

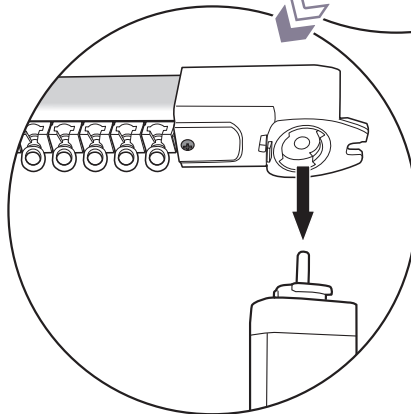
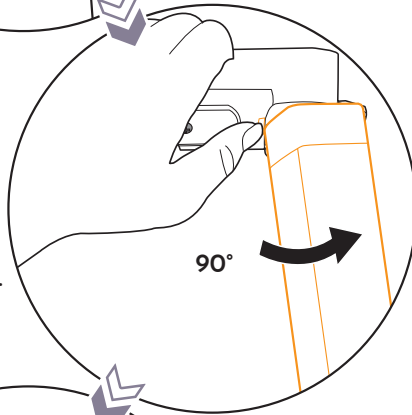

B. PARAMETERS

B-1 MOTOR

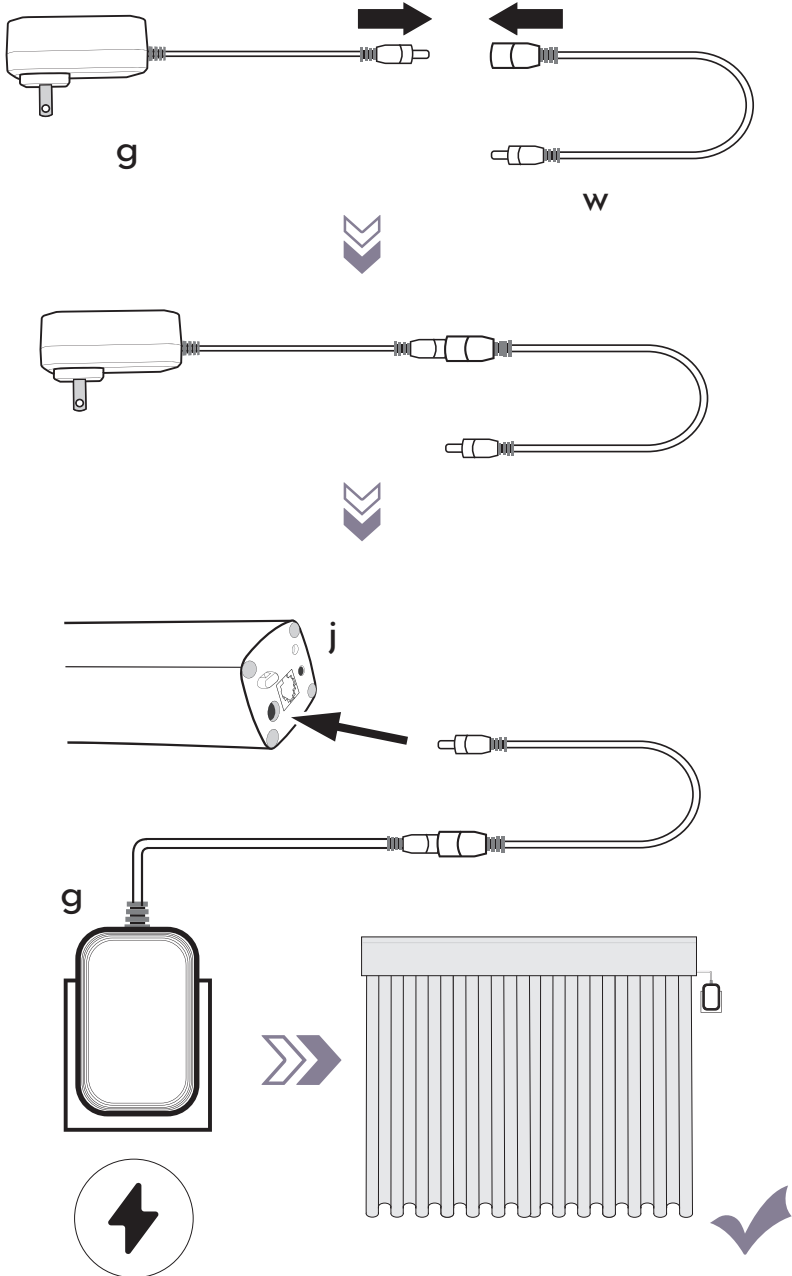

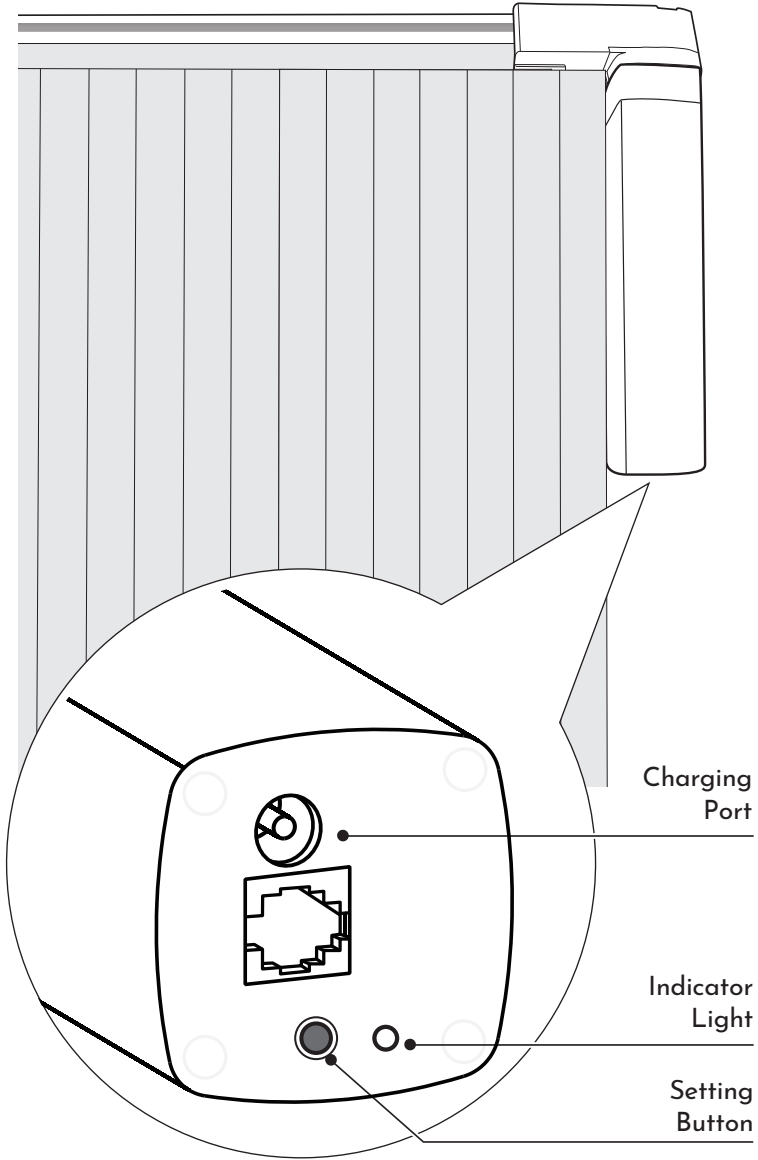

B-2 AEOLUS® REMOTE CONTROL

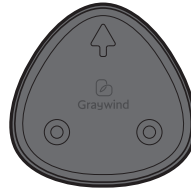
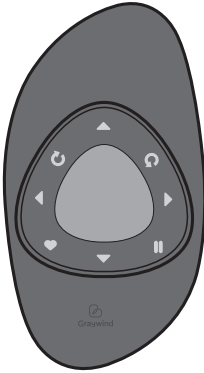

Wall Holder



S x2

INSTALL THE BATTERY



Your blind has been programmed, please control it after installation.

1



2 Use a pen to pry the back cover of the remote



Slightly press the back cover to prevent it from popping out.

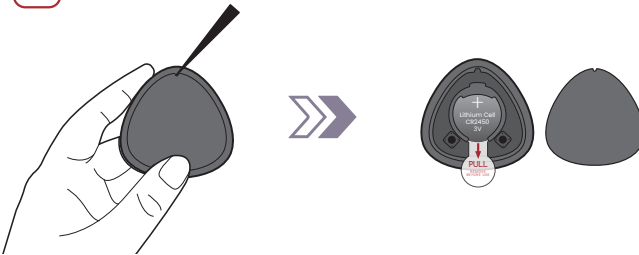

3 Remove the insulating sheet

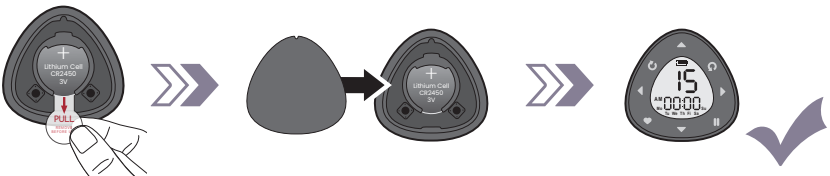

PARAMETERS

FRONT

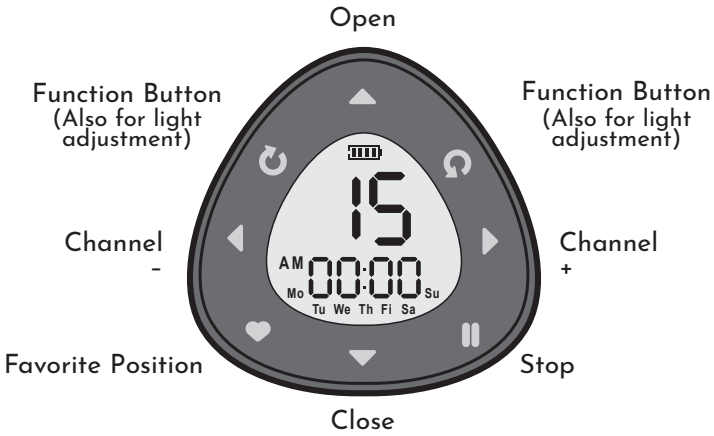

SCREEN

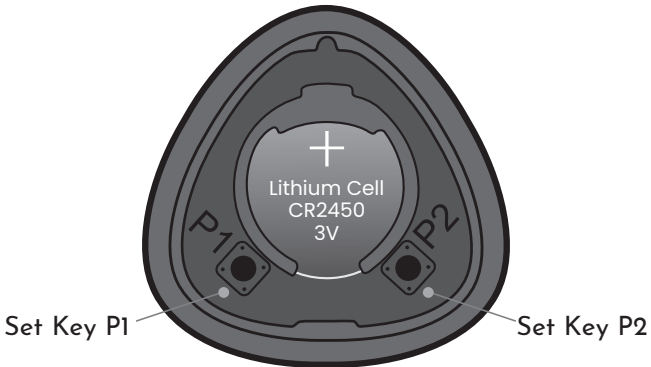
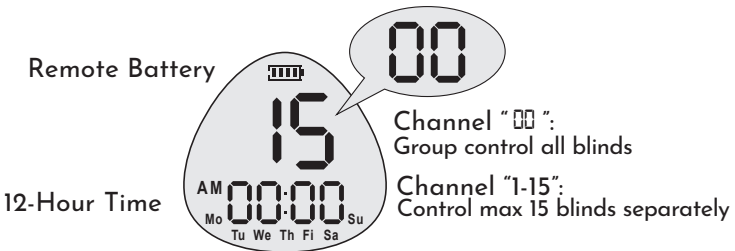

HAND HOLDER:

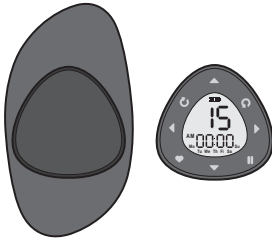

WALL HOLDER:

Method 1

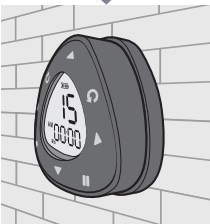
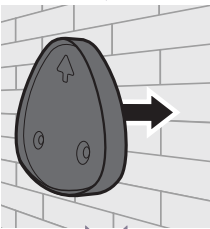
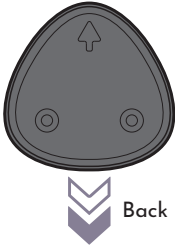

Method 2

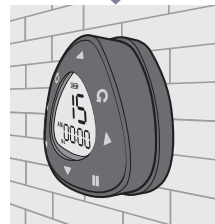
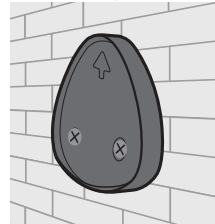
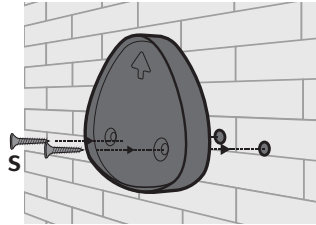
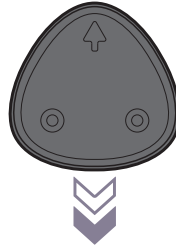

C. APP CONTROL

- 1 Download & Open APP
- 2 Sign Up/ Log In
- 3 Click "Add Device" on home page, press "Panel Track Blinds", then follow steps.

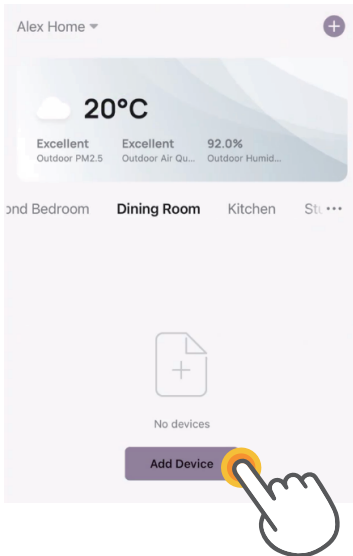

- 4 Please scan the QR code for specific operations.

PDF Version & Video Guide:

D. REMOTE CONTROL PROGRAMMING

D-1 ENTER SETTING MODE



1. It will exit setting mode if pressing "◀" or "▶".
2. It will exit setting mode if there is no operation for 3 mins.

1

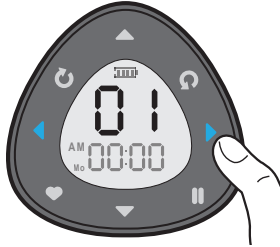

Press "◀" or "▶",
choose the channel
you want to set from "1-15"

2

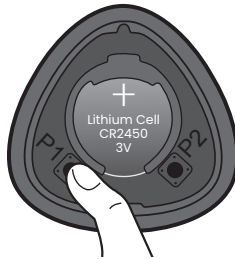

Hold "P1" for 5s



Channel flashes, enter setting mode.

D-2 CLOCK SETTING



Please ensure the remote is in setting mode before doing steps below:

1

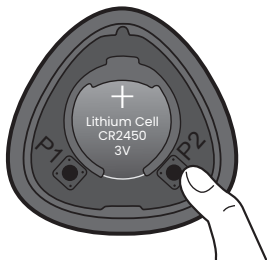

Hold " P2 "for 5s

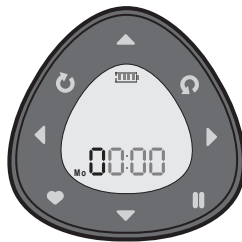

"Hour" icon flashes

2

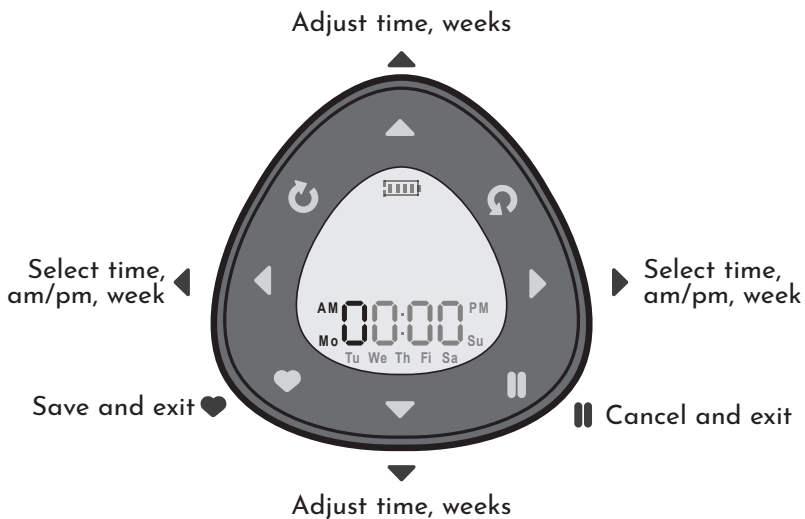

D-3 TIMING SETTING

SET:



1. You can set at most 20 groups of timing for each remote.
2. Please ensure the remote is not in setting mode before setting timing. If it's in setting mode, please refer to page 30 to exit setting mode.

1 Enter timing setting.



Hold "♥" & "||" for 3s

2 Add new timing.



Hold "↻"

3 Set timing.

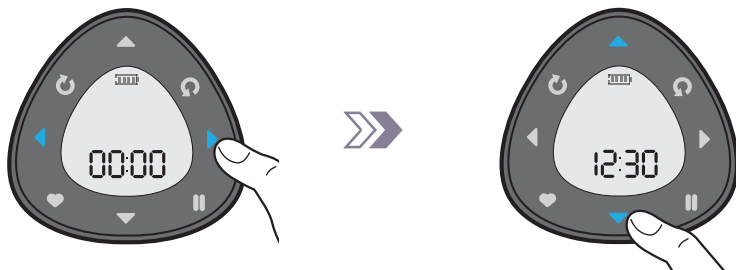

Press "◀" or "▶" to switch between hr and min, the selected part will be flashing.

Press "▲" or "▼" to select the numbers.

4 Set AM/PM.



Press "▶" and enter into AM/PM selection.
Press "◀" or "▶" to choose.



Press "▲" to save and "⊕" icon will show up.
Press "▼" to cancel and "⊕" icon will disappear.

5 Set the day of the week (Multi-choice).



Press "◀" or "▶" to select the day of the week.
The selected one will be flashing.



Press "▲" to save and "⊕" icon will show up.
Press "▼" to cancel and "⊕" icon will disappear.

6 Set action of the blind.



Press "◀" or "▶" to switch between open and close, the selected one will be flashing.



Press "▲" to save and "⊕" icon will show up.
Press "▼" to cancel and "⊕" icon will disappear.

7 Set channels (Multi-choice).



Press "◀" or "▶" to select the channel number. The selected one will be flashing.



Press "▲" to save and "⊕" icon will show up. Press "▼" to cancel and "⊖" icon will disappear.

8



Press "♥" to save the setting.

9

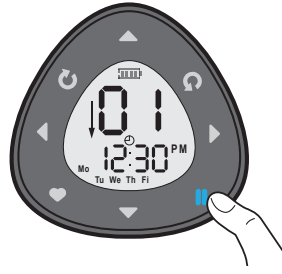

Press "||" to exit timing setting



DOUBLE CHECK:

1 Enter timing setting.



Hold "♥" & "||" for 3s



2 Confirm timing group.

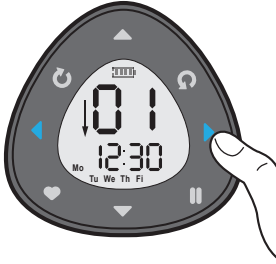

Press "◀" or "▶" to select the group of timing.

3 Confirm channels in the group.



Press "▲" or "▼" to check the channels in the group.

MODIFY:

1 Enter timing setting.



Hold "♥" & "||" for 3s



2 Select timing group.



Press "◀" or "▶" to select the group of timing.

3 Modify timing group.

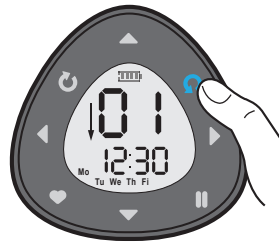

Hold "⌚" to enter in the group of timing and modify.



1. The way to modify can be referred step 3-9 in D-3(P32-P34).
2. When you modify the time, please note: 00:00 means delete this timing group.

D-4 MOTOR PROGRAMMING

JOG POSITION OF CURTAIN WHEN SETUP

Side Open

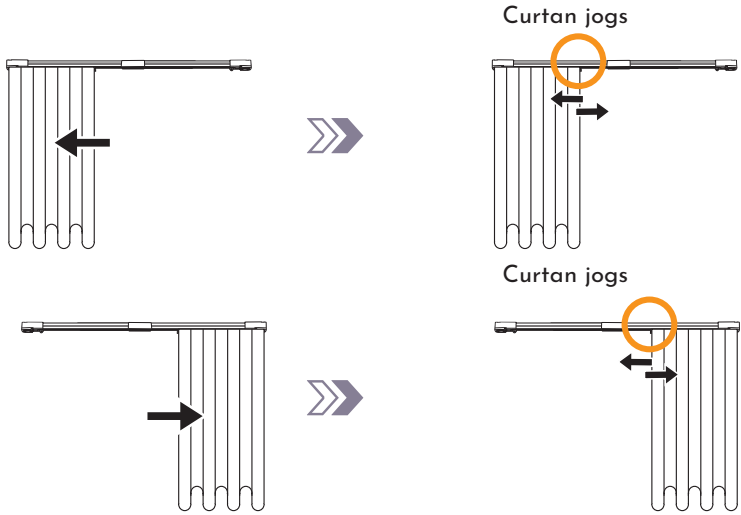

Central Open

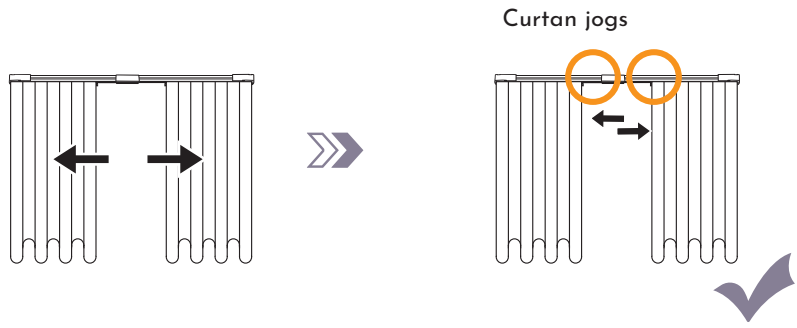

SET FAVORITE POSITION



1. Before setting the favorite running position, please make sure the fully-open and fully-closed limit positions are already set.
2. Please ensure the remote is in setting mode before doing steps below:

- 1 Run the curtain to favorite position you want to set (except fully open and fully closed)

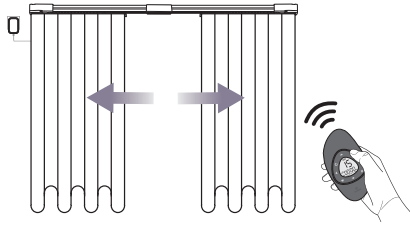

2



Press "♥" & "||"

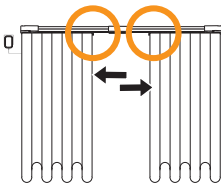

Curtain jogs 1x

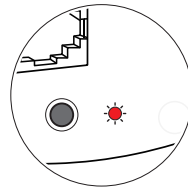

Red light flashes 1x



HOW TO CHANGE OPEN/CLOSE DIRECTION



Please ensure the remote is in setting mode before doing steps below:

1

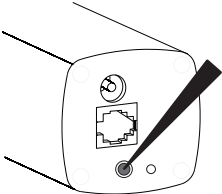

Hold for 3s

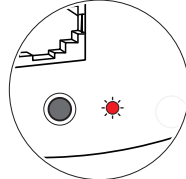

Red light is on

2



Press " 01 " & " AM Mo 00:00 "

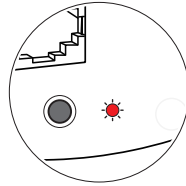

Red light flashing

3

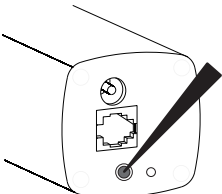

Press 1x



DELETE LIMIT POSITIONS



1. All limit positions will be deleted if doing steps below.
2. Please ensure the remote is in setting mode before doing steps below:

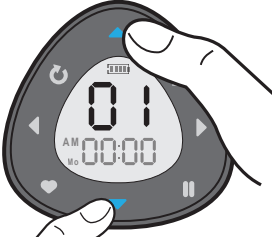

Press "▲" & "▼"

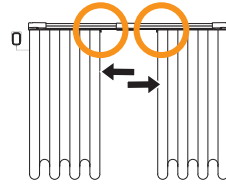

Curtain jogs 1x

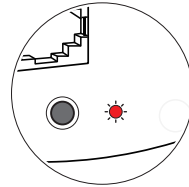

Red light flashes 1x



SET LIMIT POSITIONS



Press "▲"

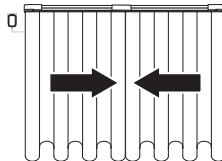
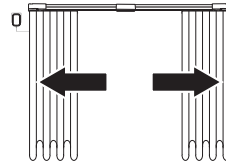

UNPAIR THE MOTOR



After doing this, all paired remotes will lose connection with the motor.

1

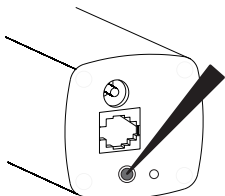

Hold for 3s

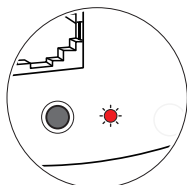

Red light is on

2

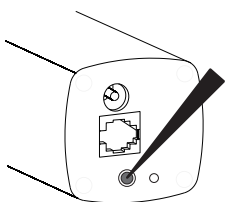

Hold for 7s

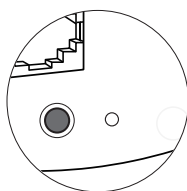

Red light is off



RE-PAIR THE MOTOR



Please ensure the remote is in setting mode before doing steps below:

1

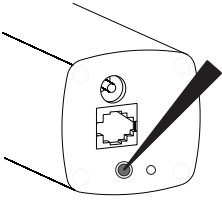

Hold for 3s

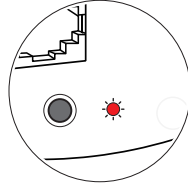

Red light is on

2

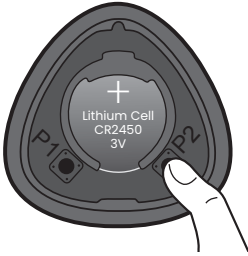

Press "P2" 5X



"H5" shows on the screen

3

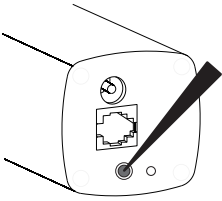

Press 1x

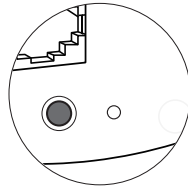

Red light is off

4

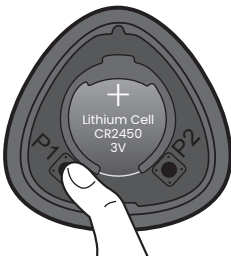

Press "P1"



"AA" shows on the screen

