

ASSEMBLY INSTRUCTIONS

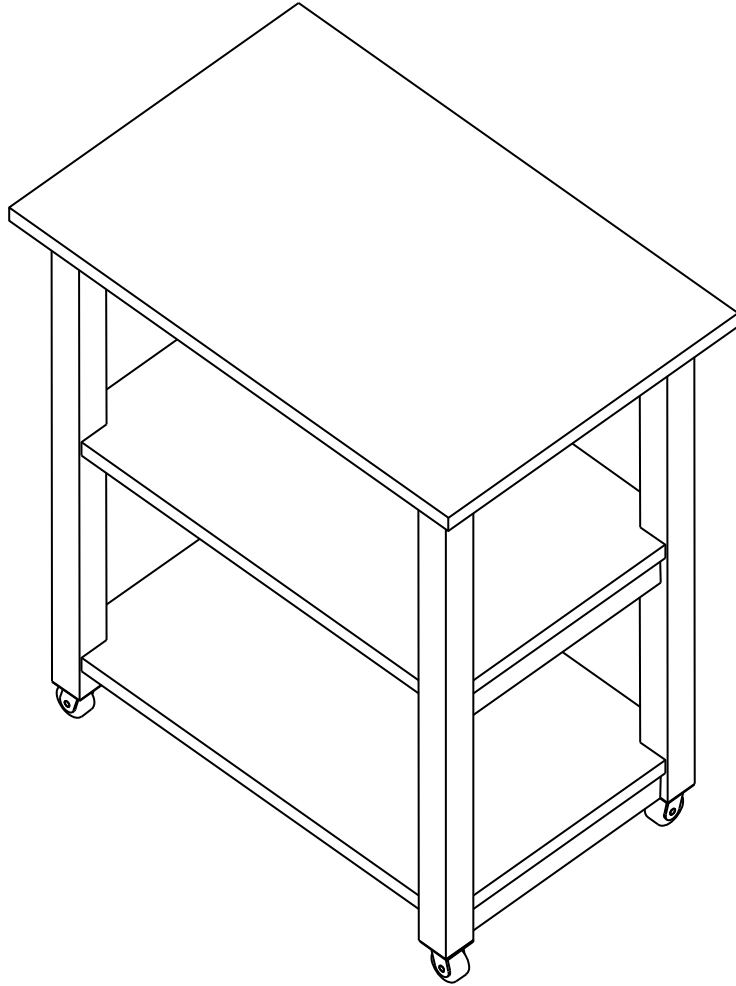

Description : MICROWAVE CART 26X17X30IN

BEFORE ASSEMBLY

Thank you for purchasing this quality product. This product has been designed for easy assembly and constructed for durability. All parts were checked prior to packaging to insure quality. Prior to beginning assembly, however, make sure all parts and hardware are included and free of obvious defect. If a part is missing or defective, hardware is missing, or you need help with assembly,

IMPORTANT NOTE:

- Place all wooden parts on a clean and smooth surface such as a rug or carpet to avoid the parts from being scratched.
- Remove all wrapping material, including staples & packing straps before you start to assemble.
- DO NOT tighten all screws and bolts until completely assembled.
- Keep all hardware parts out of reach of children.

WARNING:

Long exposure to rubber or soft plastic may cause a chemical reaction and damage the finish of your product. Protect the surface of the product with cloth if you are using any product with rubber feet or base.

ASSEMBLY TOOLS REQUIRED NOT INCLUDED





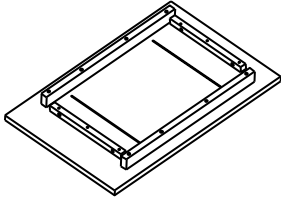
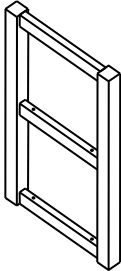
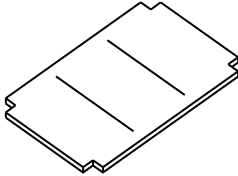

PART LIST

When unpacking, please be careful not to discard any parts with the packaging. Before continuing, please make sure you have all of the following parts:

NO	Description	Qty	Sketch	NO	Description	Qty	Sketch
A	Top	1		B	Side Frame	2	
C	Shelf	2					

HARDWARE LIST

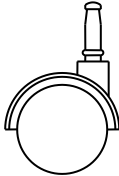
When unpacking, please be careful not to discard any parts with the packaging. Before continuing, please make sure you have all of the following hardware:

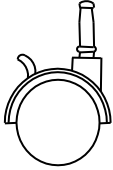
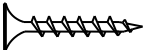
NO	Description	Qty	Sketch	NO	Description	Qty	Sketch
1	Bolt (M6 x 35mm)	4		5	Allen key (M4 x 30mm x 110mm)	1	
2	Lock Washer (Φ6.5 x 11mm)	4		6	Castor (Φ40mm)	2	
3	Flat Washer (Φ6.5 x 19mm)	4		7	Lock Castor (Φ40mm)	2	
4	Screw (M4 x 35mm)	8					

STEP 1

Attach side frames (B) to top (A) with bolts (1), and washers (2) and (3) as shown below. Tighten with Allen key (5).

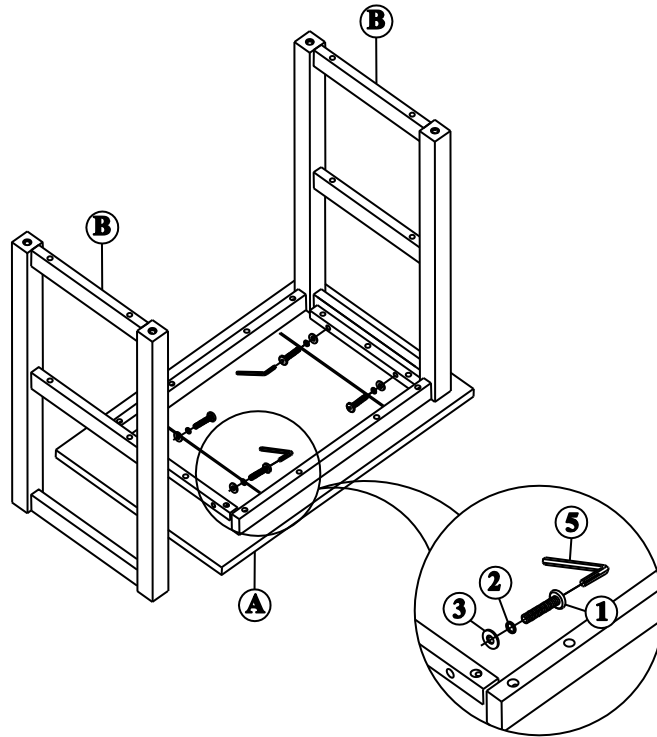

STEP 2

Attach shelves (C) to side frames (B) with screws (4) as shown below. Tighten with a screwdriver. Insert castors (6) and lock castors (7) into bottom of side frames (B), as shown below.

