

Adjustable Bed

OWNER'S MANUAL

Instruction No. KY25112501



Contact Us!

 goodcareteam@outlook.com

Contact Us!



Let Us Service You For Any Shipping Product or Return Issues!
Our quick-response customer service resolves issues faster than returns!

goodcareteam@outlook.com

TIPS:

1. Order# and phone# are needed when you first contact us
2. You can refer to page 12&13 to simply troubleshoot and provide us with detailed information to get accurate assistance.

Helpful Hints

PEOPLE NEEDED FOR ASSEMBLY: **2**

ESTIMATED ASSEMBLY TIME: **5-20** MIN

IMPORTANT SAFETY NOTICE: READ CAREFULLY BEFORE BEGINNING ASSEMBLY!

Adjustable Bed

- * Always use proper tools.
- * Follow the assembly steps in order. Do not skip any steps.
- * Be sure to check all packing materials carefully for small parts may have come loose inside the carton during shipment. If parts are missing, contact the retailer from which you purchased the product to obtain any missing parts. **DO NOT USE SUBSTITUTE PARTS.**
- * Periodically check to ensure that all connectors (bolts, screws, etc.) are tight.
- * Keep the instructions for future reference.
- * Some assembly may involve attaching glass or mirrors. Be very careful handling the glass or mirrors, as severe injury may result if the glass or mirror breaks. Never handle large pieces of glass or mirrors by yourself.
- * When assembling products that have electric cords (lamps, light, etc.), always (1) make sure the electrical cord is unplugged before assembly and (2) be careful not to twist the electrical cord during assembly.
- * When assembling shelves or entertainment centers, do not stand on lower shelves in order to assemble upper shelves—use a step ladder.
- * Do not stand on tables, including but not limited to, end tables, coffee tables, and dinner tables, as tables are not to support the weight of a person.
- * Where assembly instructions state that the assembly requires two or more people, **do not** attempt by yourself as there is a risk of injury.

 **DISCLAIMS ANY LIABILITY FOR DAMAGES OR INJURIES WHICH MAY OCCUR DUE TO FAILURE TO PROPERLY FOLLOW ASSEMBLY INSTRUCTIONS, PROPERLY ASSEMBLE THE PRODUCT, OR PROPERLY USE THE PRODUCT.**

NOTE: YOUR UNIT MAY LOOK DIFFERENT IN APPEARANCE FROM THE ONE SHOWN IN THE ILLUSTRATIONS ON THIS INSTRUCTION SHEET.

NOTICIA IMPORTANTE DE SEGURIDAD: LEA CUIDADOSAMENTE ANTES DE COMENZAR A ENSAMBLAR

- * Siempre use las herramientas apropiadas.
- * Siga los pasos de ensamble en orden. No salte ningún paso.
- * Asegúrese de comprobar con cuidado todos los materiales de embalaje en busca de piezas pequeñas que hayan podido desprenderse dentro del cartón durante el envío. Revise la lista de partes. Si faltan partes, comuníquese con el surtidor del cual usted compró el producto para obtener las partes que le faltan. **NO USE PARTES SUSTITUTAS.**
- * Periódicamente revise para asegurarse que todos los conectores (pernos, tornillos, etc.) estén bien apretados.
- * Guarde las instrucciones para referencia futura.
- * Algunos de los ensamblajes involucran vidrios o espejos. Tenga cuidado al manejar estos vidrios o espejos, ya que puede lesionarse severamente si uno de estos vidrios o espejos se rompe. Nunca maneje piezas grandes de vidrio o espejo sin ayuda.

- * Al armar productos con cables eléctricos (lamps, lights, etc.), siempre (1) asegúrese que el cable este desenchufado antes de armar (2) tengacuidado de no doblar el cable al marmar..
- * Al armar repisas o centros de entretenimiento, no se pare en las repisas de abajo para armar las repisas de arriba—use una escalera.
- * No se pare en las mesas, incluyendo pero sin límite a, mesas laterales, mesas de centro, mesas de comedor, ya que estas mesas no están construídas para soportar el peso de una persona.
- * Si las instrucciones dicen que se debe usar dos o mas personas **no** trate de armarlo solo, ya que corre el riesgo de lastimarse.

 no se hace responsable por danos o lesiones que puedan ocurrir por no seguir las instrucciones de ensamble correctamente, el ensamble apropiado del producto, o el uso apropiado del mismo

NOTA: LA UNIDAD PUEDE PRESENTAR UNA APARIENCIA DIFERENTE DE LA QUE SE MUESTRA EN LAS ILUSTRACIONES DE LA HOJA DE INSTRUCCIONES.

REMARQUE IMPORTANTE CONCERNANT LA SECURITÉ: LIRE ATTENTIVEMENT AVANT DE COMMENCER LE MONTAGE!

- * Utilisez toujours les outils adaptés.
- * Suivez l'ordre des étapes de montage. N'en sautez aucune.
- * Assurez-vous de vérifier attentivement tous les matériaux d'emballage parce que les petites pièces peuvent se détacher à l'intérieur de la boîte lors de l'expédition. Faites l'inventaire attentif de toutes les pièces. Si une ou plusieurs pièces manquent, contactez votre revendeur pour obtenir les pièces en question. **N'UTILISEZ PAS DE PIÈCES DE SUBSTITUTION.**
- * Vérifiez de temps à autre que tous les connecteurs (boulons, vis, etc.) sont bien serrés.
- * Gardez ces instructions pour pouvoir les consulter ultérieurement.
- * Certaines étapes du montage peuvent nécessiter l'installation de verres ou de miroirs. Soyez extrêmement prudent lors de la manipulation des verres ou des miroirs, car vous pourriez vous blesser gravement si le verre venait à casser. Ne manipulez jamais seul de grands objets en verre ou de grands miroirs.

- * Lors de l'assemblage des produits qui comportent des fils électriques (lampes, lumières, etc.), assurez-vous toujours (1) que le câble électrique est débranché avant de procéder au montage et (2) faites attention à ne pas secouer le câble électrique pendant le montage.
- * Lors du montage des étagères ou un meuble audio-vidéo, ne vous tenez pas sur les étagères inférieures pour installer les étagères supérieures. Utilisez un escabeau.
- * Ne vous tenez pas sur les tables, ce qui comprend mais pas uniquement, les tables d'extrémité, les tables basses, les tables à dîner, car elles ne sont pas destinées à supporter le poids des personnes.
- * Lorsque les instructions de montage mentionnent que l'installation nécessite deux personnes ou plus, n'essayez pas de monter vous-même le produit, car vous risqueriez de vous blesser.

 **NE SE TIENT AUCUNEMENT RESPONSABLE DE TOUT DOMMAGES OU BLESSURES DUS AU NON RESPECT DES INSTRUCTIONS DE MONTAGE ET D'UTILISATION DU PRODUIT.**

REMARQUE: VOTRE MEUBLE PEUT ETRE DIFFERENT DE CELUI MONTRE SUR L'ILLUSTRATION DE CETTE FEUILLE D'INSTRUCTIONS.

重要安全提示：组装家具前请仔细阅读以下指南！

- * 请使用合适的工具进行组装。
- * 按照组装步骤逐步完成，请勿跳过任一步骤。
- * 由于小的零部件有可能在运输过程中散落于包装箱内，请仔细检查包装材料。如若发现部件丢失，请及时联系当地零售商以获取丢失部件。请勿用其它零部件替代。
- * 定期检查以确保所有连接处（螺丝，螺杆等）均已拧紧。
- * 请妥善保存该安装说明，以备将来需要时参考。
- * 当产品中用到玻璃和镜子，安装时请小心操作，以防玻璃或镜子破碎造成伤害。请勿独自安装大块玻璃或者镜子。

- * 对于附有电线的产品（台灯，立灯等），安装时请确保以下两点：
 1. 安装之前确保电源断开。
 2. 安装过程中请勿扭曲电线。
- * 安装隔板或者电视柜时，请勿站在低层隔板上安装上层隔板，使用梯子进行安装。
- * 请勿站立在茶几，边几或者餐桌之类的桌子上，这些桌子不能够支撑人体重量。
- * 组装说明中一旦提及某一安装需要两到多人完成，请不要尝试独自安装，这样可能会对您人身安全构成威胁。



注意：对于未能严格按照组装说明书组装，未能正确组装产品，或者未能正确使用产品而造成的损失或伤害，将不负法律责任。
家具的表面油漆涂层需要恰当保养，为避免灰尘，请定期清洁和抛光家具。

注意：您所购买的产品与该组装说明书中配图在外观上可能会有差异。

Table of Contents

Safety & Warranty Warnings.....	01
Tips.....	02
Disclaimer and Precautions.....	03
Parts List.....	04
Installation Guide.....	05
Remote Instructions.....	09
Pairment Guidance.....	10
Electric Wiring Diagram.....	11
TROUBLESHOOTING.....	12
WARRANTY.....	14
RETURN POLICY & CUSTOMER SUPPORT.....	15

Safety & Warranty Warnings

CAREFULLY READ THE FOLLOWING INFORMATION BEFORE USING THIS PRODUCT



Failure to read, understand and follow all warnings and instructions may result in property damage, personal injury or death. If unable to understand warnings, cautions, and/or instructions, contact the dealer or technical personnel if applicable, before attempting to assemble, install or use the equipment.

SAFETY WARNINGS:

- Do not use the power foundation outdoors.
- Do not use the power foundation near any flammable chemicals, vapors or compounds.
- This appliance is not intended for use by persons (including children) with reduced physical, sensory or mental capabilities, or lack of experience and knowledge, unless they have been given supervision or instructions concerning the use of the appliance by a person responsible for their safety.
- Do not allow any person or pet under the power foundation at any time.
- During bed operation, make sure the body is positioned within the confines of the bed.

Operating Information:

- After the power foundation assembly is completed, operate the remote control to ensure proper functions before occupying the bed.
- Keep moving parts free of obstruction during power foundation operation (including sheets, clothing, tubing, wiring, and products using electric power cords).
- Distribute body weight evenly over the bed surface during operation. Do not operate the bed while sitting directly on the head or foot sections of the bed.

   **WARNINGS:** Clear the area below the power foundation before lowering the foundation to reduce the risk of injury or death.

WARRANTY WARNINGS:

Tampering with or opening the control box, motors, or remote control (with the exception of replacing batteries) will void the warranty.

RADIO FREQUENCY: 2.4 GHz

FCC COMPLIANCE:

This device complies with Part 15 of the FCC Rules. Operation is subject to the following two conditions: (1) This device may not cause harmful interference, and (2) this device must accept any interference received, including interference that may cause undesired operation.

To comply with the FCC RF exposure requirements, no change to the antenna or the device is permitted. Any change to the antenna or the device could result in the device exceeding the RF exposure requirement and void user's right to operate the device.

Tips

1. After the power base is raised, it cannot bear the weight of 99lb or more, and children over 99 lb are prohibited from jumping and playing on the raised part.

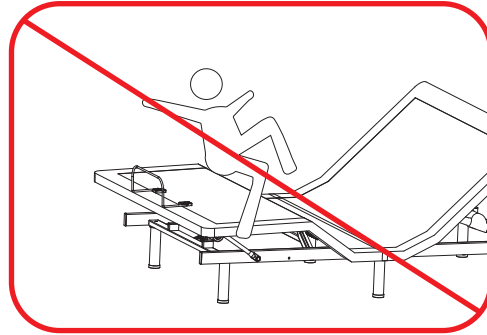
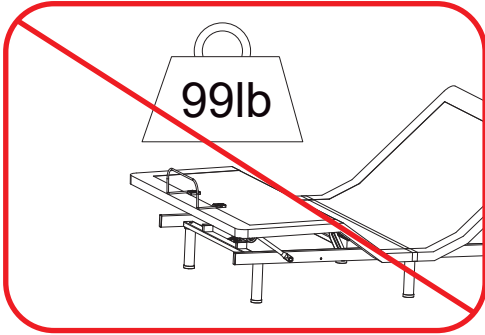

2. After the power base is raised, it is forbidden to push the back of the power base vigorously, and it is forbidden to vigorously pull the foot part of the power base.

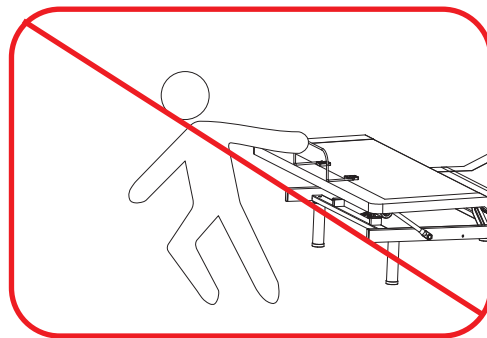
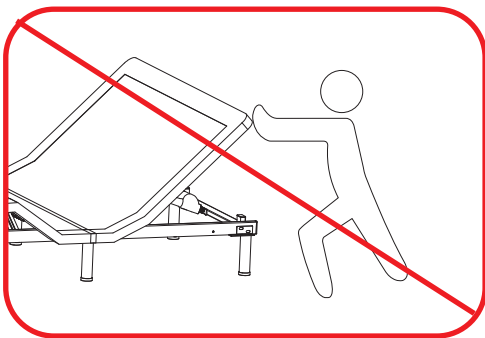

3. Before lifting the bed, avoid placing the entire weight on the individual head or foot sections.

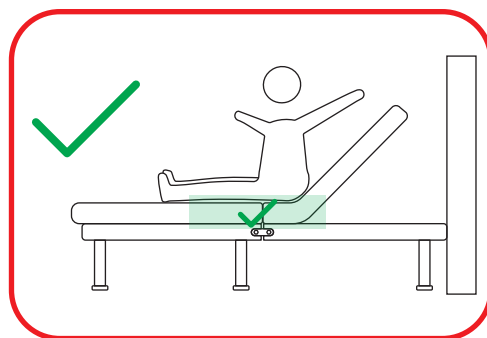
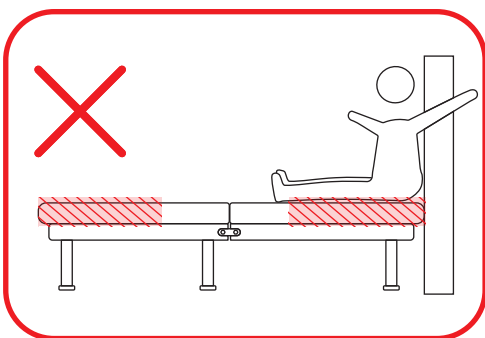

Disclaimer and Precautions

1. Connect the power correctly

Please connect the power supply correctly, it is recommended to use a current protector (not provided with this power base), this power base should be connected to a fixed socket. Incorrect power connections may cause electric shock or fire, etc. Damage to motors and appliances due to incorrect power connection will void the warranty.

2. Avoid electric shock

During the use of this power base, please do not open or disassemble any parts of this power base without authorization. Please unplug the power supply before repairing this power base and cleaning this power base to avoid electric shock, and ensure that the power supply is kept away from any flammable and high-temperature objects.

3. Make sure the power cord is always kept away from hot, flammable objects

4. After the power base is raised, it is forbidden to jump on the raised power base or push or break the raised part

5. Beware of pinch injuries

During the movement of the parts of this power base, please stay away from the moving parts to prevent pinching.

6. Children and pets

Please dispose of the packaging of this power base in time to avoid harming children and pets. To avoid injury, it is not recommended for children and pets to play under the power base, please place the remote control in a place that is not easy for children to reach. Children must be supervised by an adult when using this power base.

7. Correct use of accessories

Please refer to this manual to correctly use these accessories. Please use only the accessories provided or approved by the company. Otherwise, damage to the base may not be covered under warranty.

8. Warranty warning

Do not open or modify the central control box, motor, and remote control (except for replacing the remote control batteries). Otherwise, the warranty will not be obtained. For detailed warranty regulations, please refer to the warranty card.

Parts List

All electronics and components that need to be installed are located in boxes under the foundation or attached to the frame. Before discarding the packing materials, ensure that all the parts are accounted for.

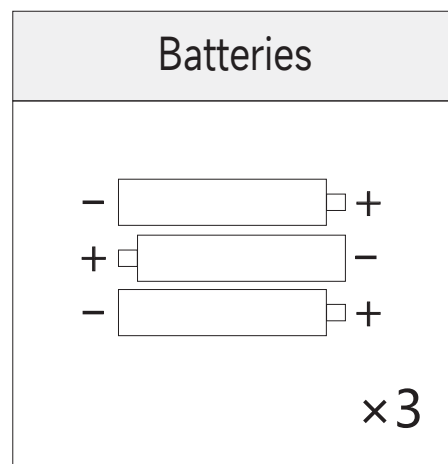
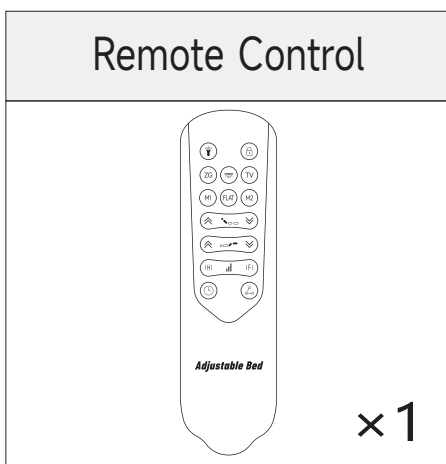
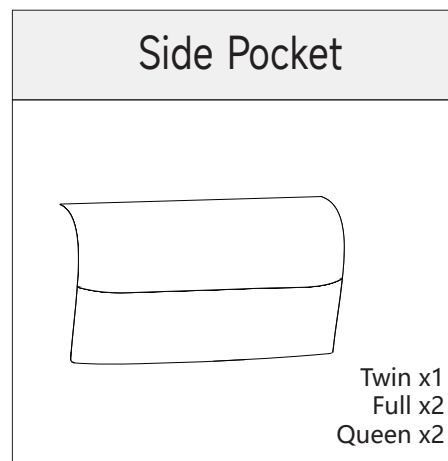
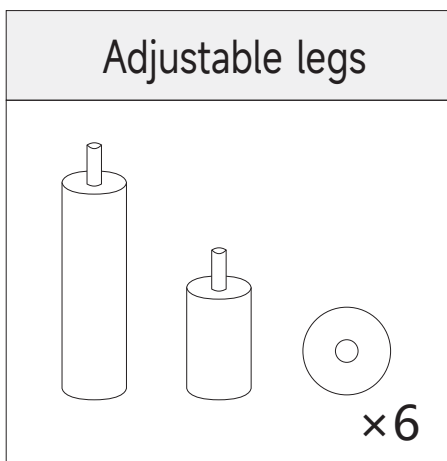
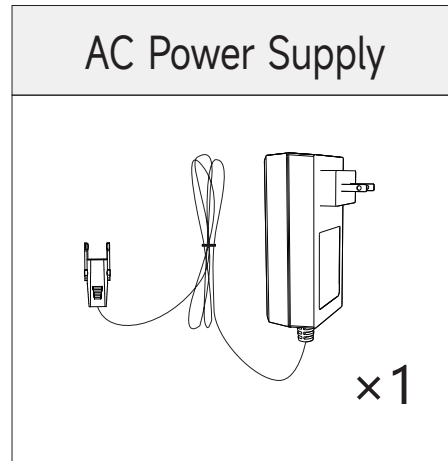
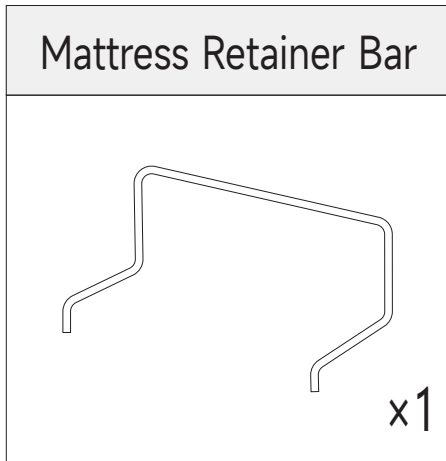

Put batteries in the remote. Pay attention that all the remotes has been paired to the bed frame in the factory.

Installation Guide

Two people are required to set up the foundation.

1

Lift the folded bed frame unit out of the shipping carton carefully, and then put it on a flat floor. Unlock the wire securing, take out the accessory boxes & the mattress retainer bar. Inventory the accessories according to the parts list, contact our customer service if there are missing parts.

Customer Service Email : goodcareteam@outlook.com

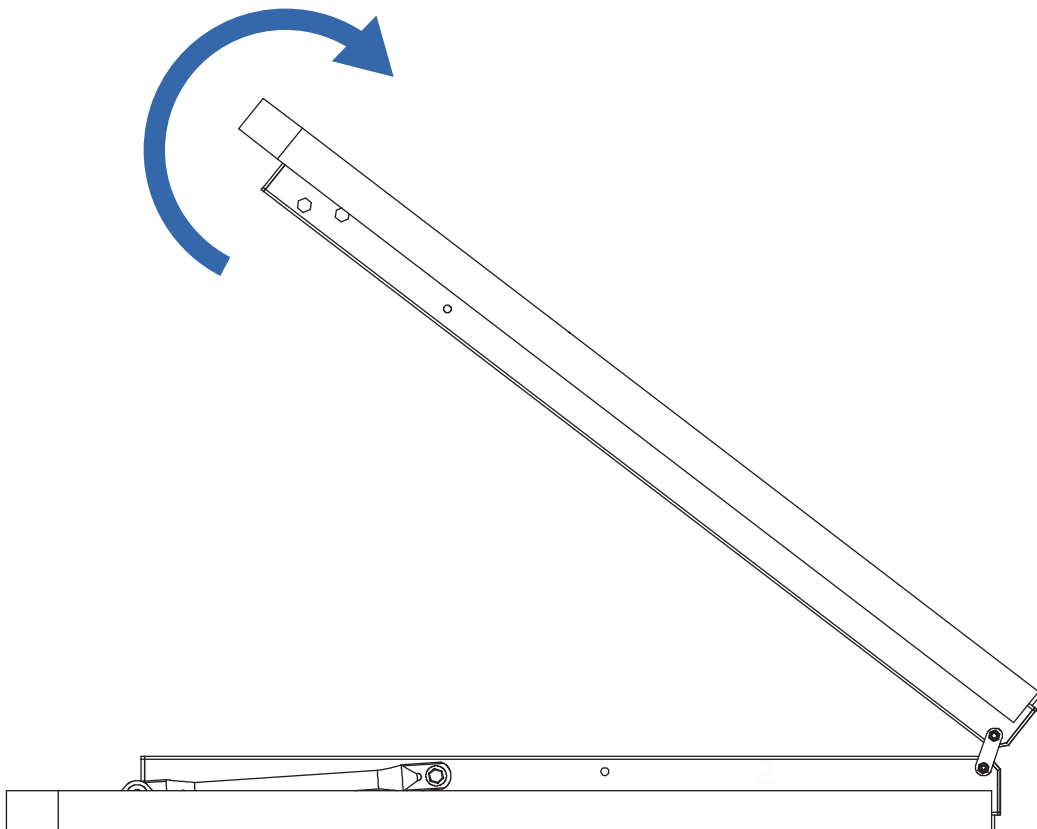

Customer Service Email : goodcareteam@outlook.com

Installation Guide

Two people are required to set up the foundation.

2

To install all six legs, first place the washers onto the nuts under the power base. Then, thread both legs onto the nuts and hand-tighten them securely.

Tip: When installing the washer, please ensure that the raised side of the washer is positioned toward the bed frame.

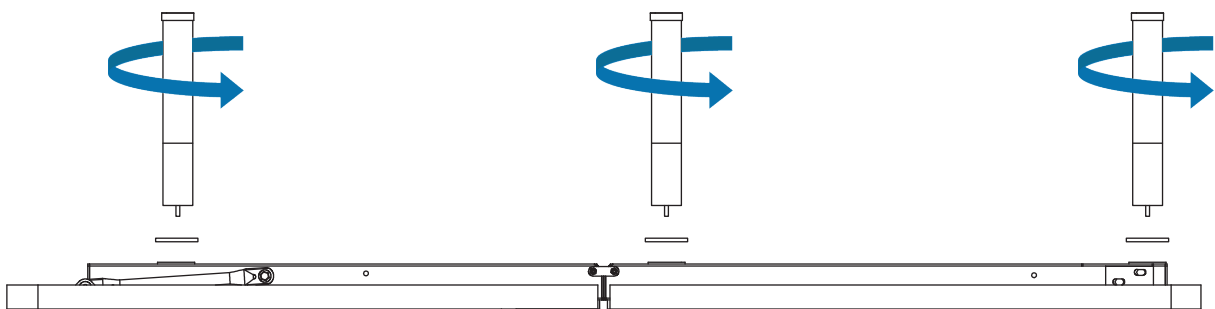
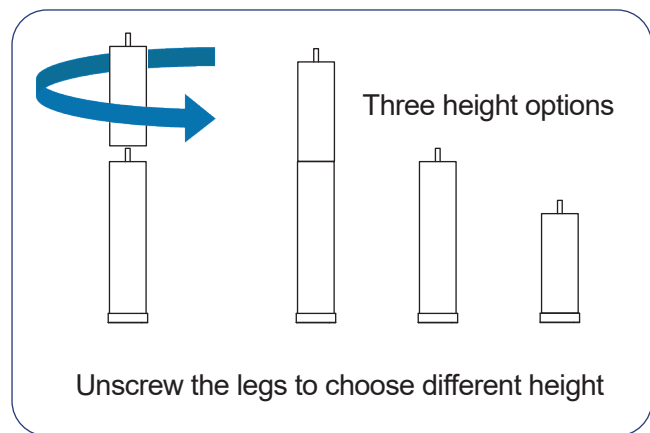
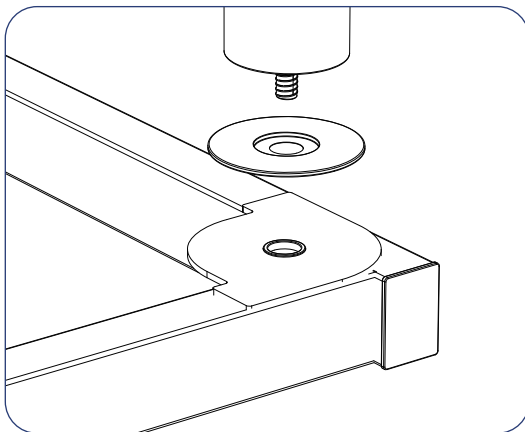

Installation Guide

Two people are required to set up the foundation.

3

Take the AC power cord from the accessory box and connect it to the power port on the control box. Then plug the AC power supply into the outlet.

*Note: DO NOT pull the power cord forcibly.

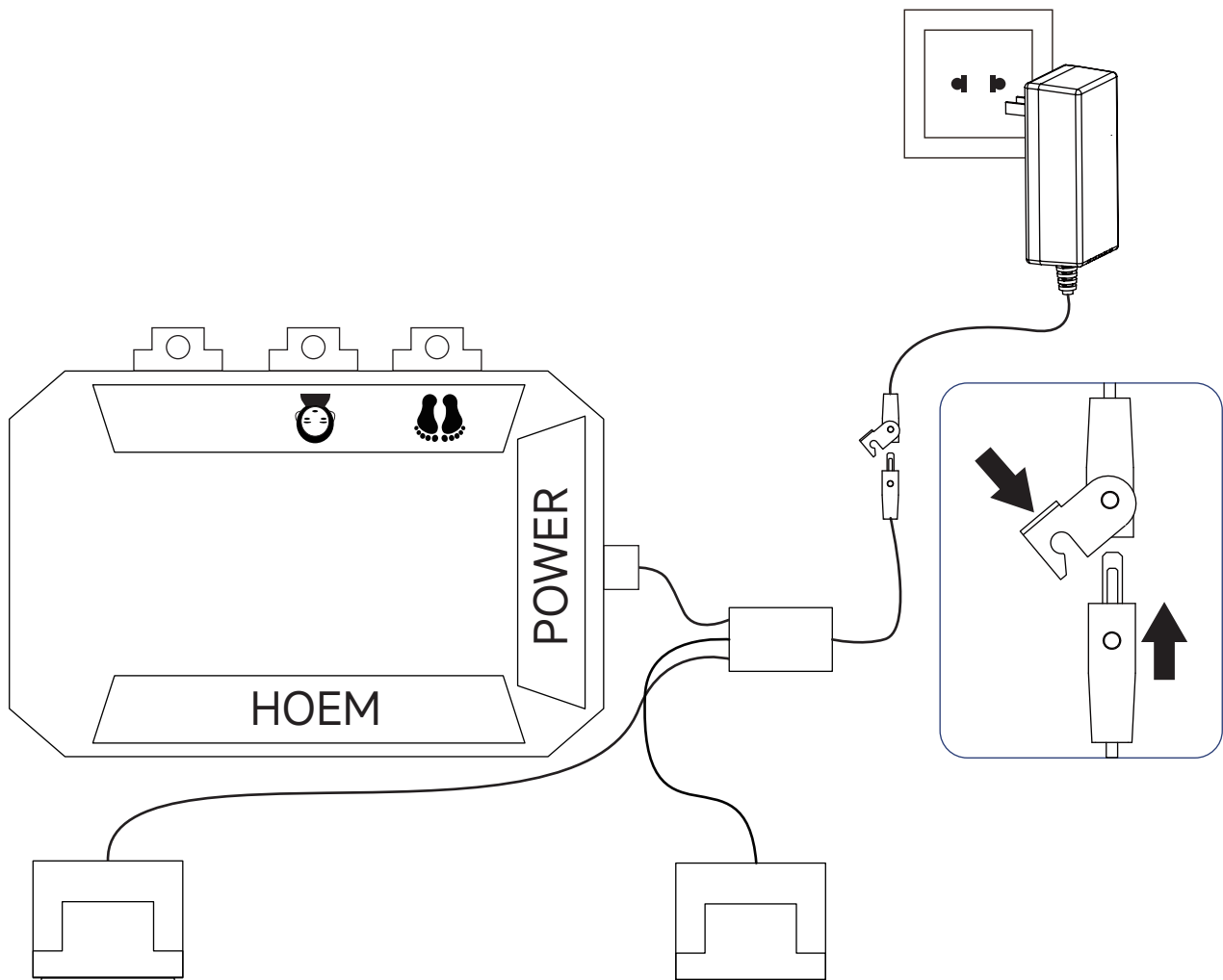

Important Note: Due to long-distance shipping, there is a potential for wires to become loose. Please check all wires and ensure that all ports are securely connected.

Customer Service Email : goodcareteam@outlook.com

Installation Guide

Two people are required to set up the foundation.

4

Two people are required to work together to turn the power base over and lay it flat on the ground. Insert the mattress retainer bar. Attach the side pocket to the middle of the bed base.

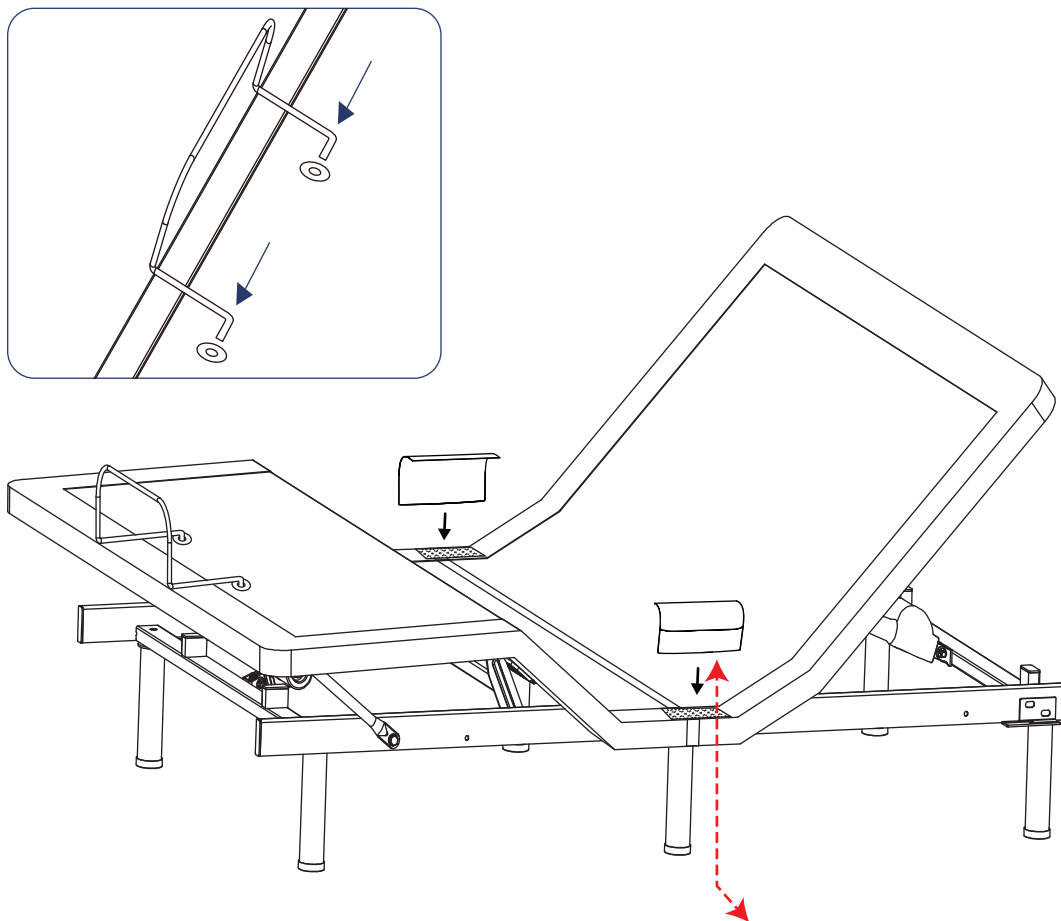

Twin XL bed has only ONE side pocket.

Remote Control Instructions

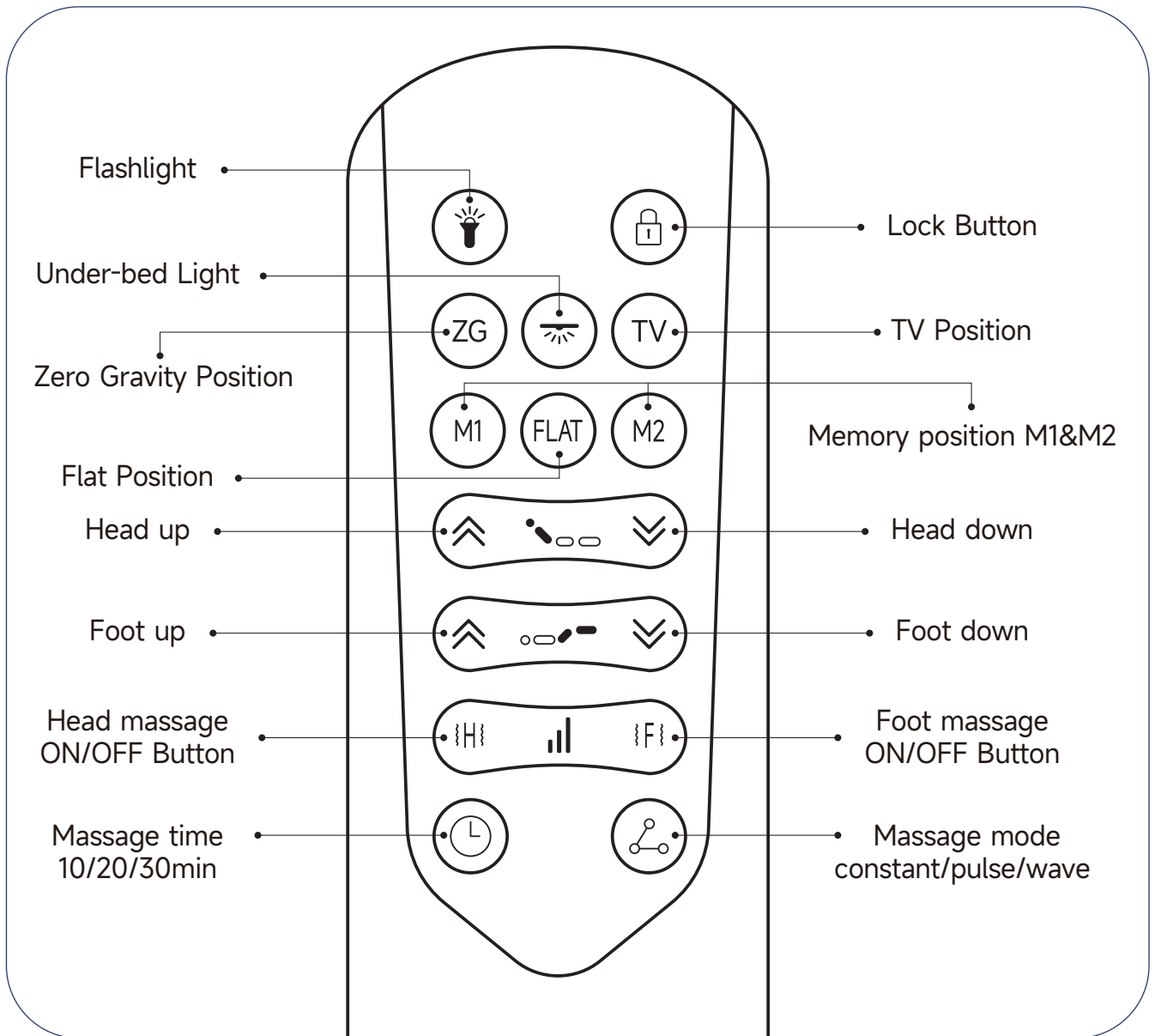

Set Lock Button:

Hold for 3 seconds to set, hold again for 3 seconds to cancel.



Set Message Timer Button:

First, please turn on the message timer and then activate the message function. (blue indicator for 10 minutes, green for 20 minutes, red for 30 minutes)

Setting Memory Position:

1. Adjust the head and foot to your desired position.
2. Press and hold the FOOT UP and FOOT DOWN button for 3 seconds until the back-lit starts flashing. The light will flash for 6 seconds; during this time, press the M1 button to successfully set the memory position to M1.

Pairing Split King Base Instructions:

Place the two Twin XL Bases to form a Split King Base.

1. To Control Both Bases Synchronously:

- Unplug the AC power from both Twin XL bases and wait 15 seconds until the green light turns off. Then reconnect them.
- Within two minutes, select one remote and press and hold the BACK UP and BACK DOWN buttons until the backlight flashes.
- Once it stops flashing, you can use this remote to control both bases.

2. To Control Each Base Independently:

- Unplug the AC power from one Twin XL base and wait 15 seconds until the green light turns off. Then reconnect it.
- Within two minutes, select a remote and press and hold the BACK UP and BACK DOWN buttons until the backlight flashes.
- Repeat this for the other Twin XL base.
- Once the backlight stops flashing, you can use both remotes to control the bases separately.

Re-pair Remote Control Instructions:

Note: The remote and base are paired in the factory, so normally there is no need to re-pair. If there are any issues with the base, please first refer to pages 12-13 for troubleshooting, and re-pair if necessary.

1. Unplug the AC power and wait 15 seconds until the green light turns off. Then reconnect it.
2. Within 2 minutes, press and hold the BACK UP and BACK DOWN buttons until the backlight flashes. Once the backlight stops flashing, you can try to control the bed again.

Electric Wiring Diagram

Electronics Quick Reference Guide

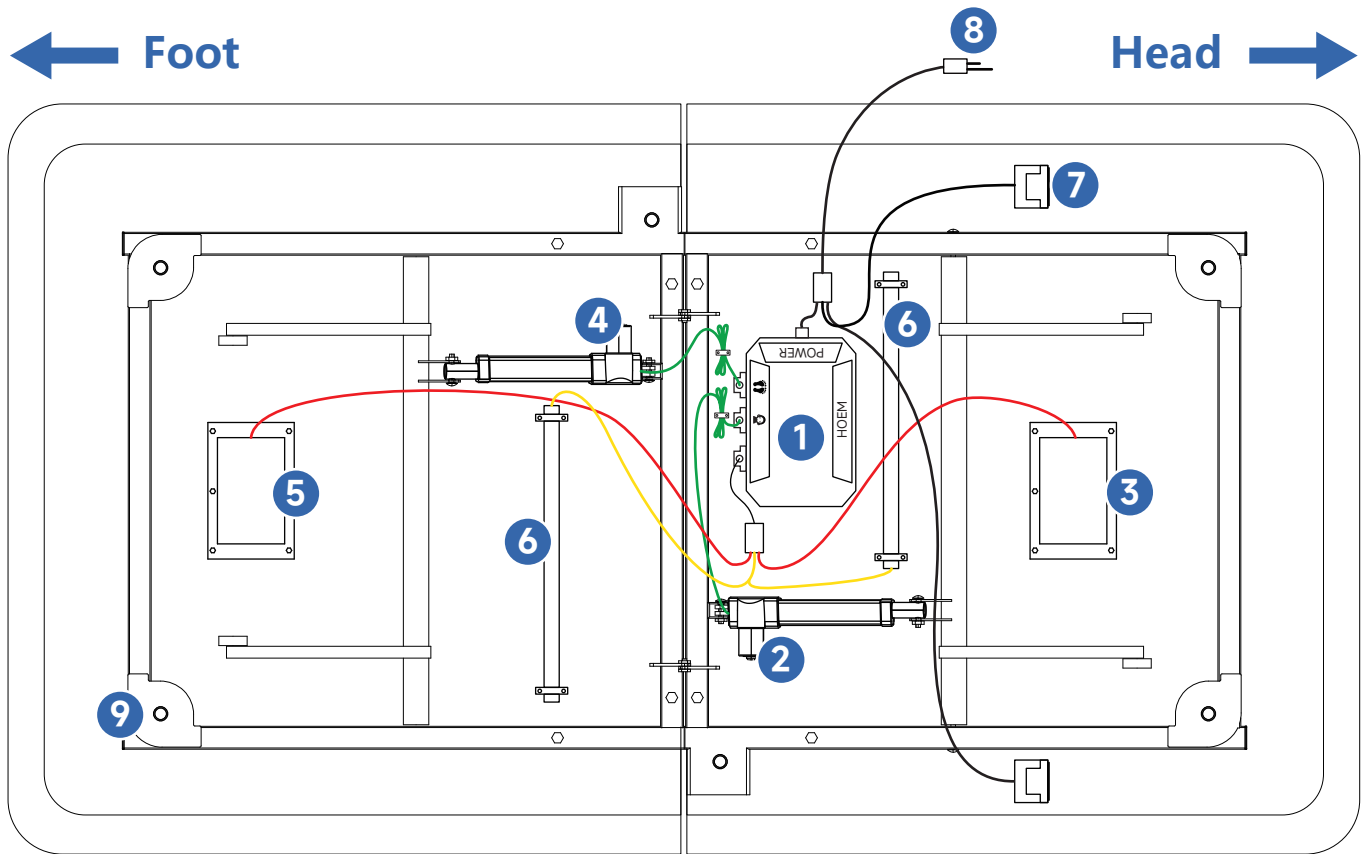

- | | |
|----------------------|--------------|
| ① Control box | ⑥ LED lights |
| ② Head motor | ⑦ USB ports |
| ③ Head massage motor | ⑧ AC power |
| ④ Foot motor | ⑨ Leg base |
| ⑤ Foot massage motor | |

If your remote control is lost, you can use the spare flat button on the control box to return the bed to the flat position. Then contact customer service for a new remote.

Customer Service Email : goodcareteam@outlook.com



IMPORTANT

ALL POWER BASES ARE TESTED BEFORE SHIPPING TO ENSURE PROPER LIFTING FUNCTION.

Customer Service Email :
goodcareteam@outlook.com

If issues arise from rough handling during transportation, improper packing, or incorrect usage, please do a simple troubleshooting and contact our after-sale service email, or the shopping platform mailbox.

Customer service will provide a solution within 12-24 hours, including weekends.

To analyze and solve your problem, when you first contact us, please provide your order number, phone number, describe the issues you met and the troubleshooting steps you've tried.

Thank you for your time.

# 1 The remote can not control the bed / The independent head and foot sections cannot elevate properly	
Step 1: Check if the remote is powered on (with white backlight).	After replacing the new battery and still no white backlight, please contact customer service: goodcareteam@outlook.com
Step 2: Check if the AC power is powered on (with green light).	Use other devices to confirm the outlet is powered on. If there is still no green light, please contact customer service: goodcareteam@outlook.com
Step 3: Check if the cords under the bed are loose.	Turn over the bed frame, refer to the "electronics reference guide" on page 11, and make sure all the cords are plugged and tightened into the correct control box ports. Note: Take a clear photo of the bed bottom for later use
Step 4: Re-pair the remote control with the bed.	1. Unplug the AC power and wait 15 seconds until the green light turns off. Then reconnect it. 2. Within 2 minutes, press and hold the BACK UP and BACK DOWN buttons until the backlight flashes. Once the backlight stops flashing, you can try to control the bed again.
After checking the steps above, the problem is still not solved.	Please send us your troubleshooting results and the photo of the bed bottom to the customer service: goodcareteam@outlook.com

2 Invalid USB ports/ LED lights/ Massage

Check if the cords under the bed are loose.	Turn over the bed frame, refer to the "electronics reference guide" on page 11, and make sure all the cords are plugged and tightened into the correct control box ports. Note: Take a clear photo of the bed bottom for later use.
If it still doesn't work after plugging in the cable.	Please send the problems and the photo of the bed bottom to the customer service: goodcareteam@outlook.com

3 Head/foot elevates but does not return to the flat position / The power base is stuck in a certain position

Step 1: Ensure the headboard is not too close to the edge of the bed frame.	Move the headboard further from the wall
Step 2: Ensure that the power base is not blocked.	Elevate the bed to check for obstruction and remove it if there is.
Step 3: Same as "Troubleshooting #1"	Same as "Troubleshooting #1"
After checking the steps above, the problem is still not solved.	Please send us your troubleshooting results and the photo of the bed bottom to the customer service: goodcareteam@outlook.com

4 Abnormal noise of motor

Step 1: Record a clear video of the motor noise in a quiet environment.	Contact our customer service team at goodcareteam@outlook.com
Step 2: Turn over the bed frame, take a clear photo of the bed bottom.	

5 The bed frame is unstable

Step 1: Check the levelness of the floor.	Adjust the power base to horizontal ground
Step 2: Check if the bed leg screws are loose.	Tighten the screws of the bed legs

6 Massage overheats or stops

Thermal protection causes motor to shut down	Wait for 30 minutes to restart the massage, if it does not work, please contact our customer service team at goodcareteam@outlook.com
--	--

WARRANTY

Notice

- Within 2 years from the date of purchase, we will cover the material costs and standard shipping fees for all warranted parts.
- From the 3rd to 5th year, we will provide repair materials and accessories, and the customer covers shipping costs for the repair.
- After the warranty period expires, we can provide replacement parts at a discounted price, if available.
- For products beyond the limited manufacturer warranty period and scope, we can also provide replacement service if available, but a basic charge will be charged based on the circumstances.
- Warranties are only valid in the 48 contiguous United States and are contingent upon the consumer operating the product according to the corresponding instruction manual.

Bed Frame	★ 5 Year
Motor and Electronic Components	★ 2 Year
Remote and Control Box	★ 1 Year

NOTE:

Weight limit for this power base is: Twin XL 750 lbs, Full / Queen 850 lbs (including the mattress). Distribute body weight evenly over bed surface. DO NOT place entire weight on head or foot sections of the bed, even while repositioning, entering, or exiting the bed. Exceeding this weight restriction could damage the bed and/or cause injury and will void the warranty.

CONSUMER WARRANTY LIMITATIONS AND EXCLUSIONS

All warranties begin on the date of purchase date.

Warranty valid for original purchaser only. Original proof of purchase required.

- We will replace the defective parts provided that the warranty parts have not been subjected to misuse, abuse or improper service by the consumer, for example, damaged wire arising in consequence of negligence or improper operation.
- Exclusions also include components with damage caused by:
 - Contamination
 - Abuse, misuse, accident, or negligence
 - Commercial use, or use other than normal
 - Improper operation, maintenance, or storage

Customer Service Email : goodcareteam@outlook.com

RETURN POLICY & CUSTOMER SUPPORT

Notice

Why don't we recommend returning the item by yourself?

- Huge cost- FedEx/UPS oversize fee.
- Need you to take the box to FedEx/UPS facility.
- Improper packaging may result in additional fees charged by FedEx/UPS.

Return/ Replacement Policy

You have 30 days from the date of purchase to return any item purchased from our store.

Please securely pack the item in its original packaging, including any accessories or manuals that came with the product, To initiate a return, please contact our customer service team in advance at goodcareteam@outlook.com for quicker help, or Contact the Seller from shopping platform.

Return Conditions

We accept the return of items that are in new, unused condition, with original tags attached and all original packaging and other components included. Refunds will be issued in the original form of payment for the price of the item, including taxes.

NOTE:

- Please keep the original packaging in case the product needs to be returned, If the original packaging is not available, the newly found packaging needs to meet the following size standard:
FedEx/UPS packaging size standard: Twin size (Width + Height) × 2 + Length < 128 inches;
Full/Queen size < 160 inches
- Please disassemble the product before you return it, otherwise there will be a huge cost as oversized and it could even exceed your order amount.
- Please do not purchase return label for a damaged/defective product by yourself.

CUSTOMER SUPPORT EMAIL

If for any reason, we have fallen short of your expectations, or if you have any questions and suggests please refer to the following contact information, we will do our best to work with you to make sure you are entirely satisfied.



goodcareteam@outlook.com
(Respond within 24 hours)

Customer Service Email : goodcareteam@outlook.com