

NOTICE

- * Please make sure that you have all parts indicated and they are in good condition before you begin assembly of this item. Refer to part list and hardware list below for guidance.
- * This item should be assembled on a soft surface to prevent scratching the finish during assembly.
- * This item may require periodic Tightening.
- * If you are having difficulty, our friendly Customer Care team is always here to help.

PREPARATION



- * Before beginning assembly of product, make sure all parts are present. Compare parts with part contents list and hardware contents list.
- * If any part is missing or damaged, do not attempt to assemble the product.
- * Estimated Assembly Time: 10 minutes.
- * Tools Required for Assembly (Included) : Wrench.

CARE AND MAINTENANCE

INDOOR METAL/ALUMINUM FURNITURE: Wipe spills immediately. Maintain with regular dusting and clean with mild soap and water, dry thoroughly and do not use a brass cleaner. Adhesive felt pads should always be used/applied in order to prevent damage to the furniture or surfaces on which the furniture is placed.

MARBLE FURNITURE CARE: Blot up spills immediately, use coasters on table tops under beverages. Use trivets or mats under hot dishes or cookware. Clean with warm water and dry surface immediately after cleaning. Do not use cleaners that contain acid such as bathroom cleaners, grout cleaner, and tile cleaners. Do not use abrasive cleaners in either dry or liquid forms. Use a cleaner and polish formulated for marble surfaces.

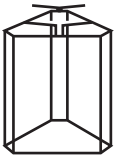
Part List and Hardware List

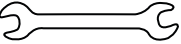
PIECE	DESCRIPTION	PICTURE	QUANTITY
A	Stand		1X1
B	Marble Top		1X1
C	Nut - M10 (17X8 MM)		1X1
D	Hardware (Wrench)		1X1

Product Dimensions: 18.5”W X18.5” D X 19.5” H

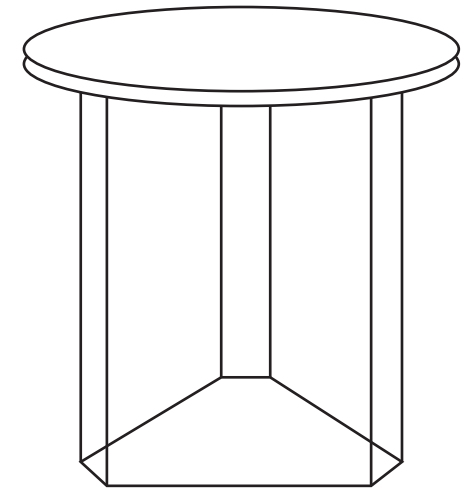

Weight Capacity : 80 LBS

Warning : Do not stand on Table

Warning : Do not over torque bolts.

PREPARATION

- * Before beginning assembly of product, make sure all parts are present. Compare parts with part contents list and hardware contents list.
- * If any part is missing or damaged, do not attempt to assemble the product.
- * Estimated Assembly Time: 10 minutes.
- * Tools Required for Assembly (Included) : Wrench.

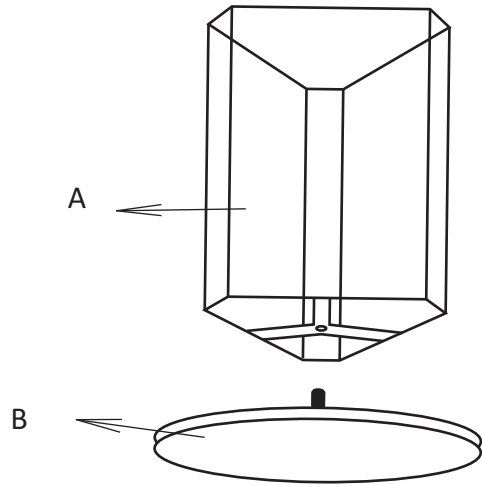

STEP1: Place Stand (A) on top of Marble top (B)

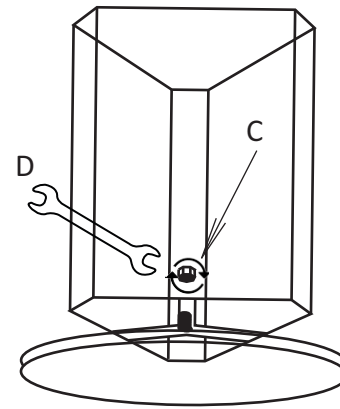

STEP2: Tight Nut (C) on marble top (B) screw
With wrench (D)

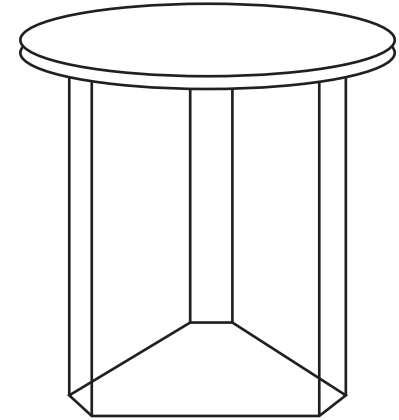

STEP3: Final Product