

# Assembly Instructions

Item No.: F7310, F7320, F7548, F7549, F7550

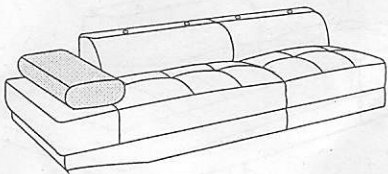

A

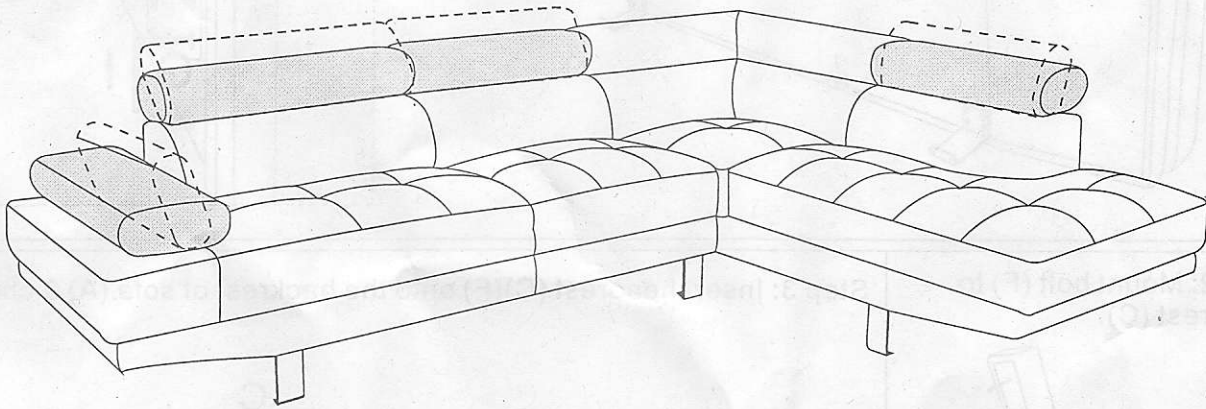
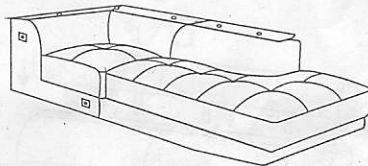

B

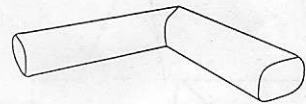

X1

C

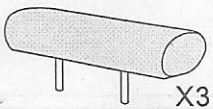

X3

D



X8

E



X3

F



X32

G

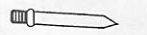

X2

H



X2

I

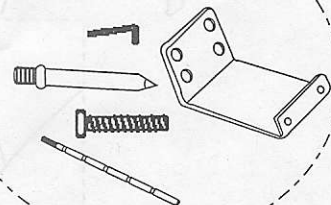
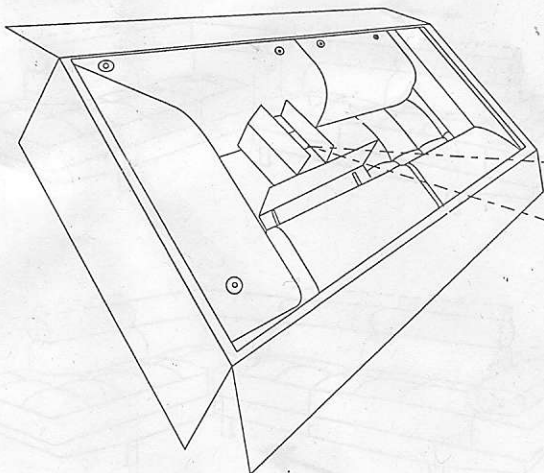

Step 1: Assemble the leg (E) onto the seat frame (A & B) with 4pcs bolt (G) by Allen wrench (I)

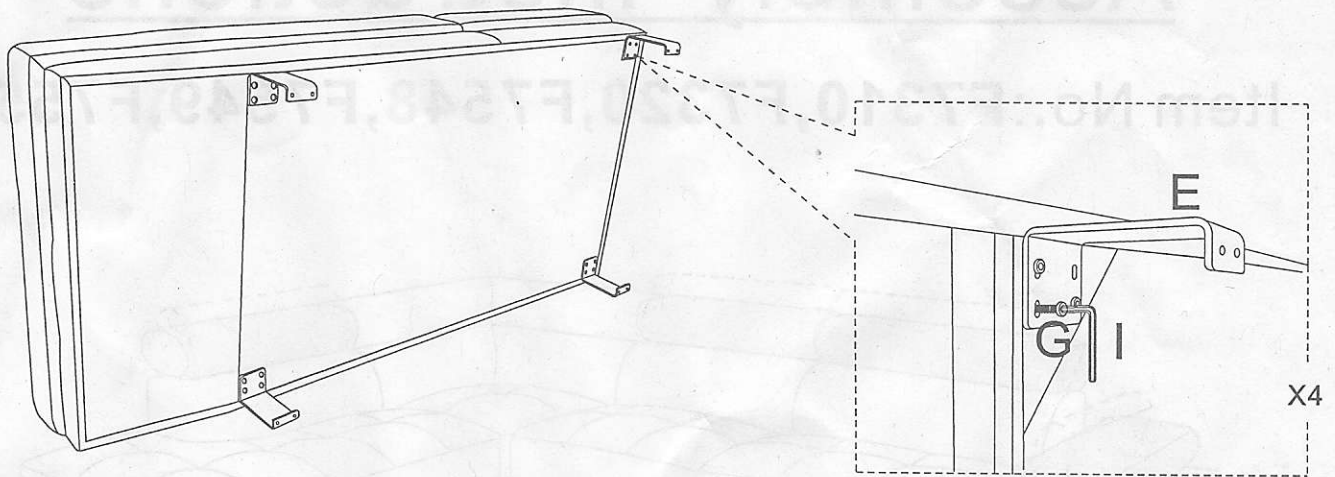

Step 2: Mount bolt (F) to headrest (C).

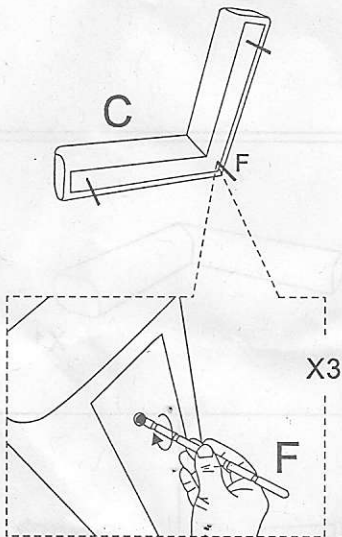

Step 3: Insert headrest (C)(F) onto the backrest of sofa (A) & chaise (B).

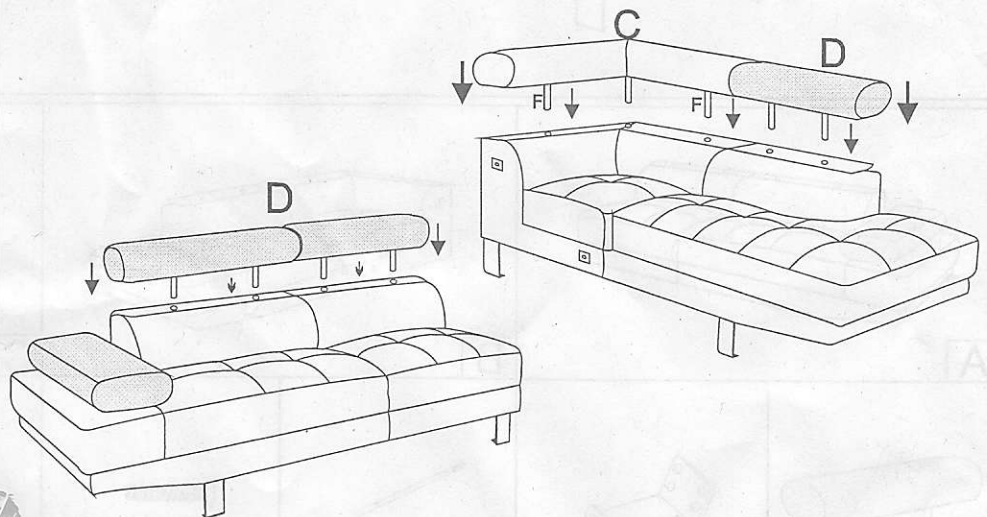

Step 4: Mount the connecting bolt (H) to sofa (A)

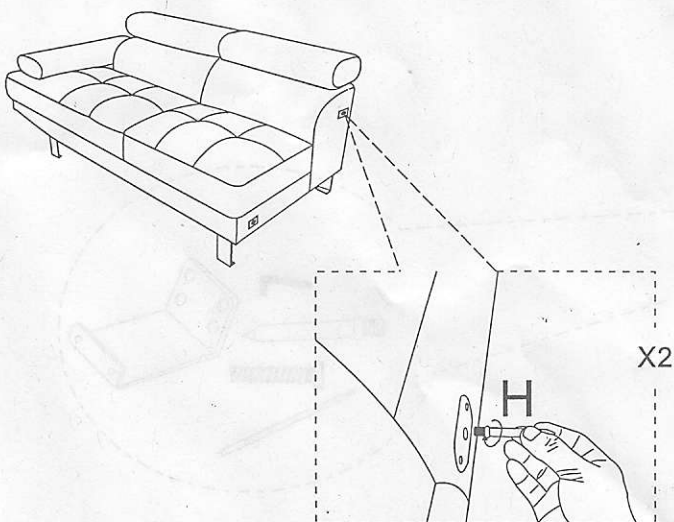

Step 5: Align the connecting bolt (H) with the assembling holes on chaise (B) to tighten sofa (A) and chaise (B) together.

