



SKU:KHD-DC-T06

SKU:KHD-DC-T06-A2

Lot No.: GYZN-NO.1

Assembly Guide

Tip!

Do check for all the components and screws listed in this guide before putting things together. If any part is missing, contact us at support@vecelo.com (US / CA) or support-euteam@vecelo.com (EU) for the missing part.

Return Policy

Your satisfaction is our top priority. If our product fails to satisfy you, please let us know how we can make things right for you. Our trained customer care team can handle most concerns and assist you with any questions you may have. Simply shoot them a message at support@vecelo.com(US/CA) or support-euteam@vecelo.com(EU) with your orde rnumber and question. To be eligible for a full-refund return, the item must be in pristine condition, in the original packaging, with all of the shipped components intact and not yet assembled, and with the item's unique proof of purchase.

Trouble shooting:

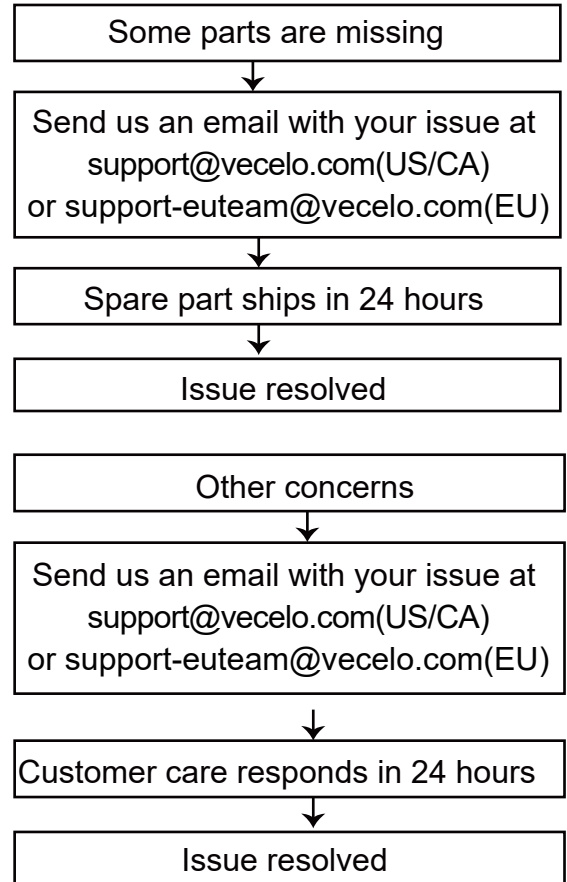

We run our own manufacturer, so rest assured about the quality consistency.

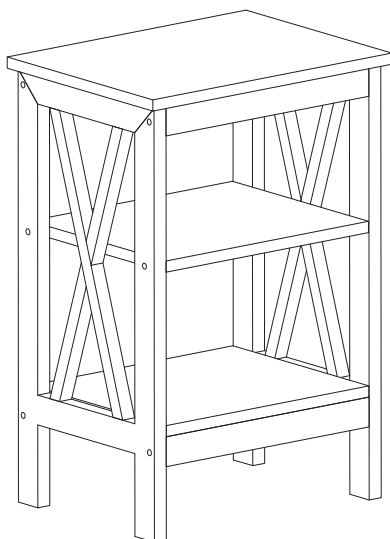

Item Description: Night Stand

Model NO: GYZN-NO.1

Montageanleitung

Tipp!

ÜBERPRÜFEN Sie alle in dieser Anleitung aufgeführten Komponenten und Schrauben, bevor Sie die Bauteile zusammenbauen. Sollte ein Bauteil fehlen, kontaktieren Sie uns unter support-euteam@vecelo.com um Ersatz zu erhalten.

Rückgaberichtlinie

Ihre Zufriedenheit ist unsere oberste Priorität. Wenn Sie mit unserem Produkt nicht zufrieden sind, lassen Sie uns bitte wissen, wie wir die Angelegenheit für Sie in Ordnung bringen können. Unser geschultes Kundenbetreu kann die meisten Anliegen lösen und unter Sie bei allen Ihren Fragen. Senden Sie uns einfach eine Nachricht an support-euteam@vecelo.com mit Ihrer Bestellnummer und Ihrer Frage. Um eine volle Rückerstattung zu erhalten, muss der Artikel in einwandfreiem Zustand sein und sich in der Originalverpackung mit allen gelieferten und noch nicht zusammengebaute Komponenten befinden. Zudem wird der eindeutige Kaufnachweis des Artikels.

Problemlösung:

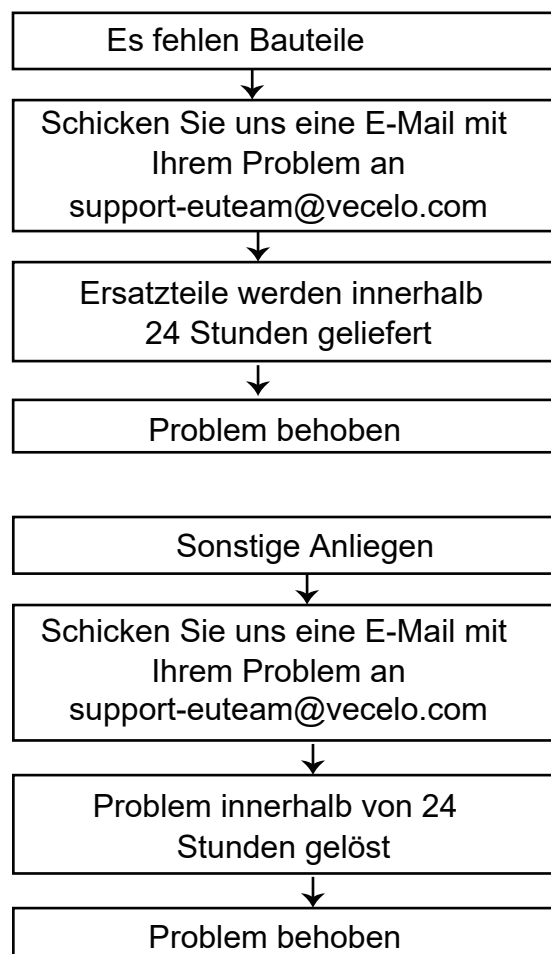

Wir stellen unsere Artikel selbst her, sodass Sie sich auf gleichbleibende Qualität verlassen können.

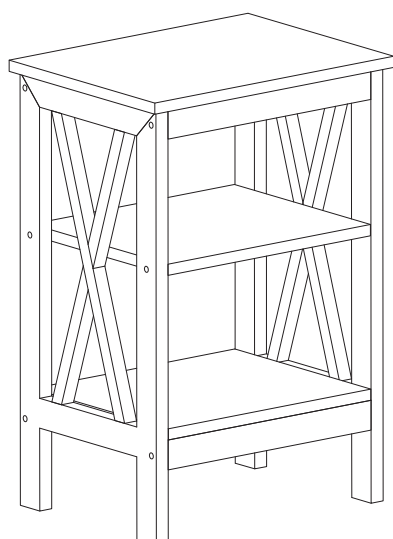

Item Description: Nachttisch

Model NO: GYZN-NO.1

Guía de montaje

Consejo!

Verifique todos los componentes y tornillos. Enumerados en esta guía antes de poner las cosas juntos. Si falta alguna pieza, contáctanos al support-euteam@vecelo.com por los desaparecidos parte.

Política de devoluciones

Su satisfacción es nuestra máxima prioridad. Si nuestro el producto no le satisface, háganoslo saber. CÓMO podemos hacer las cosas bien para usted. Nuestro equipo de atención al cliente capacitado puede manejar la mayoría inquietudes y ayudarle con cualquier pregunta es posible que tengas. Simplemente envíales un mensaje en support-euteam@vecelo.com con su número de pedido y pregunta. Ser elegible

para una devolución con reembolso completo, el artículo debe estar en impecable estado, en el embalaje original, con todos los componentes enviados intactos y aún no ensamblado y con la característica única del artículo. Comprobante de compra.

Solución de problemas:

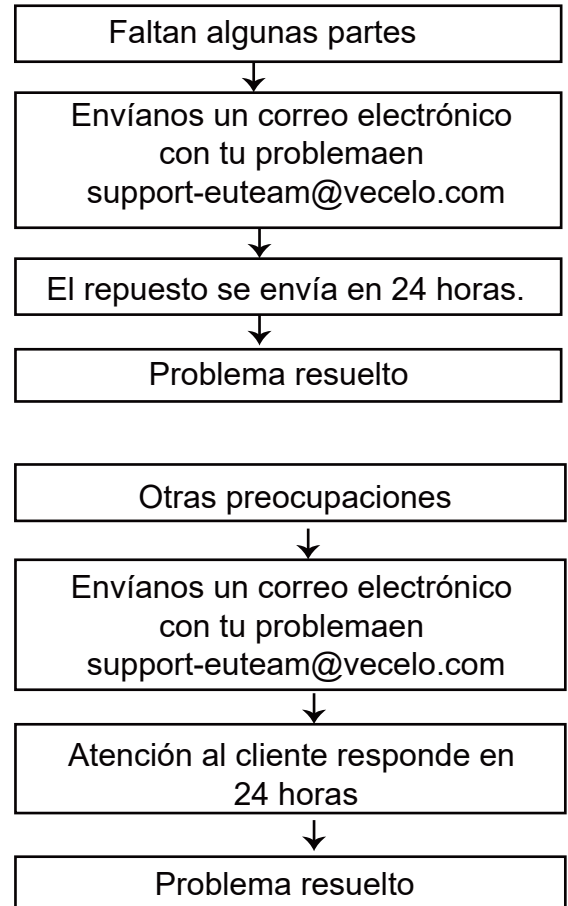

Dirigimos nuestro propio fabricante, así que descansa. Asegurado sobre la consistencia de la calidad

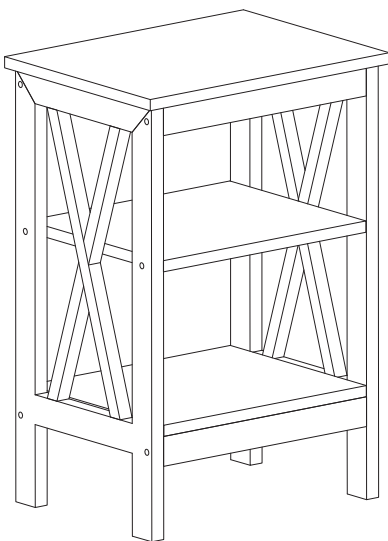

Descripción del artículo: Mesita de noche

Modelo NO: GYZN-NO.1

Guide de montage

Attention !

VÉRIFIEZ la présence de l'ensemble des éléments et vis énumérés dans ce guide avant de procéder au montage. Si une pièce venait à manquer, envoyez-nous un e-mail à support-euteam@vecelo.com pour nous le signaler.

Politique de retour

Votre satisfaction est notre priorité absolue. Si notre produit ne vous donne pas entière satisfaction, n'hésitez pas à nous faire savoir ce que nous pouvons faire pour améliorer la situation. Notre équipe d'assistance à la clientèle qualifiée est en mesure de résoudre la plupart de vos problèmes et de répondre à toutes vos questions. Il vous suffit de leur envoyer un message à l'adresse support-euteam@vecelo.com en indiquant votre numéro de commande et votre question. Pour pouvoir bénéficier d'un remboursement intégral, l'article doit être en parfait état, dans son emballage d'origine, avec tous les composants expédiés intacts et non encore assemblés, et avec la preuve d'achat unique de l'article.

Dépannage :

Certains pièces manquent



Envoyez-nous un e-mail en nous expliquant votre problème à support-euteam@vecelo.com



Pièces de rechange envoyées dans les 24 heures



Problème résolu

Vous avez d'autres problèmes ?



Envoyez-nous un e-mail en nous expliquant votre problème à support-euteam@vecelo.com



Problème résolu dans les 24 heures



Problème résolu

Nous assurons notre propre fabrication, donc soyez assuré de bénéficier d'une qualité constante.

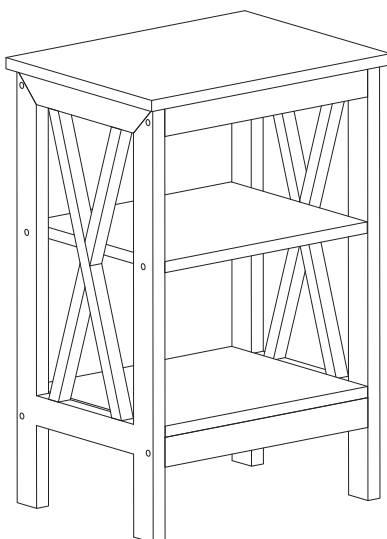

Item Description: Table de nuit

Model NO: GYZN-NO.1

Guida all'assemblaggio

Mancia!

Controllare tutti i componenti e le viti elencati in questa guida prima di inserire le cose insieme. Se manca qualche parte, contattaci a support-euteam@vecelo.com per i dispersi parte.

Politica di ritorno

La vostra soddisfazione è la nostra massima priorità. Se il nostro il prodotto non ti soddisfa, faccelo sapere come possiamo sistemare le cose per te. Nostro un team di assistenza clienti qualificato può gestire la maggior parte preoccupazioni e assistervi per qualsiasi domanda tu forse hai. Invia loro semplicemente un messaggio a support-euteam@vecelo.com con il tuo numero d'ordine e domanda. Essere eleggibile per un reso con rimborso completo, l'articolo deve essere presente ottime condizioni, nella confezione originale, con tutti i componenti spediti intatti e non ancora assemblato e con l'oggetto unico prova d'acquisto.

Risoluzione dei problemi:

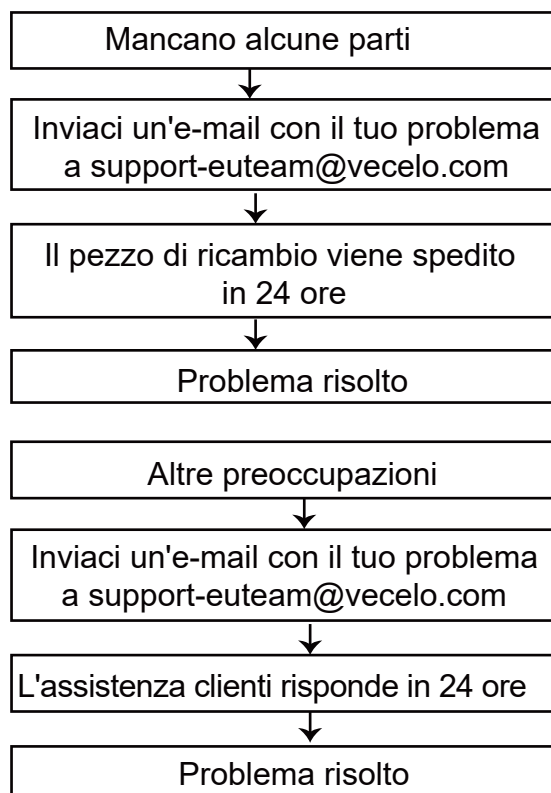

Gestiamo il nostro produttore, quindi riposati assicurato circa la consistenza di qualità.

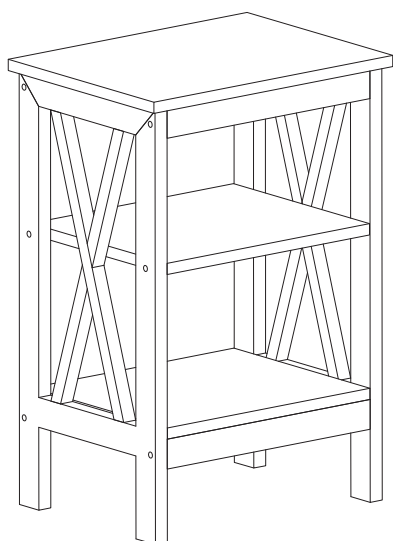

Descrizione dell'articolo: Comodino

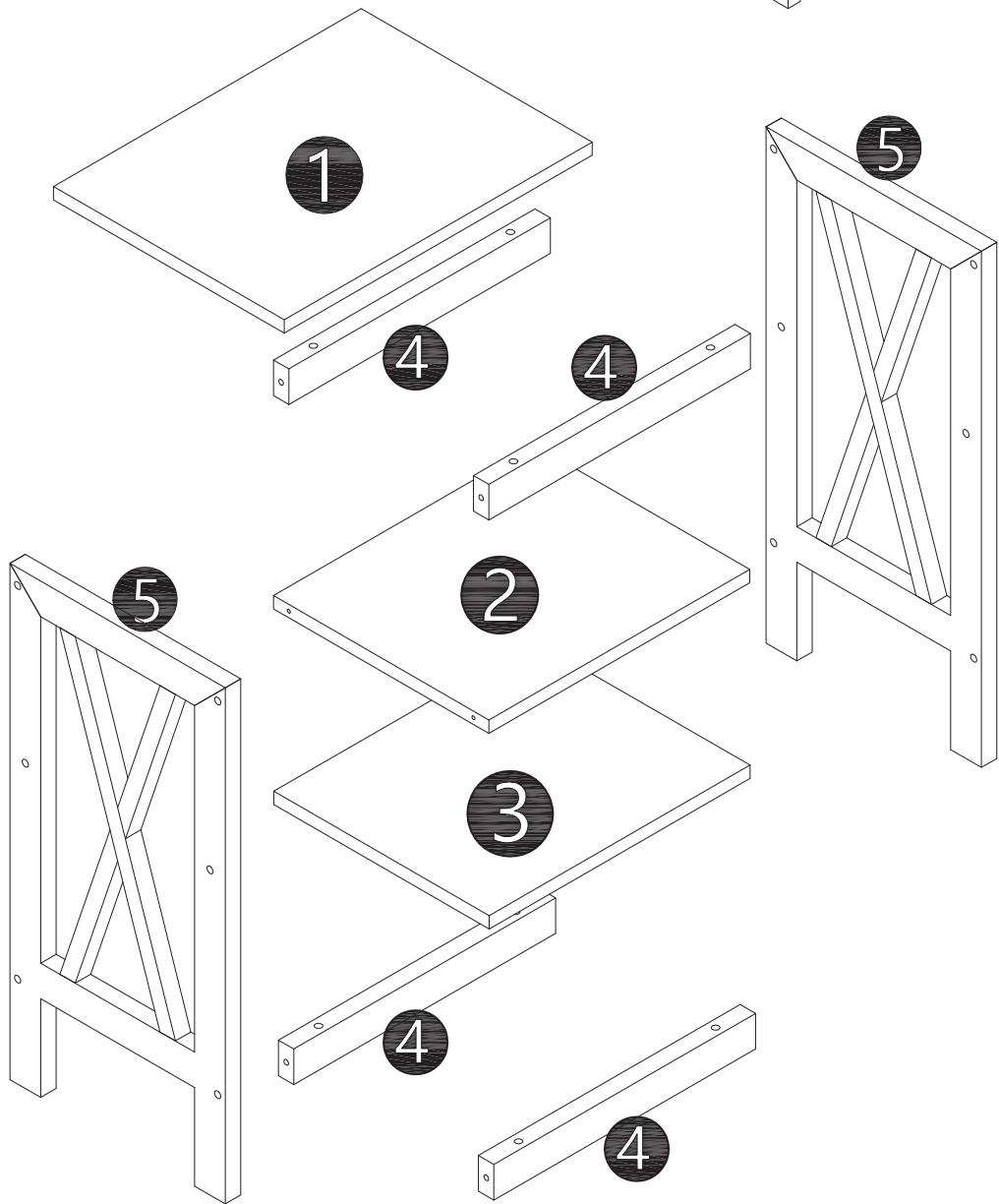
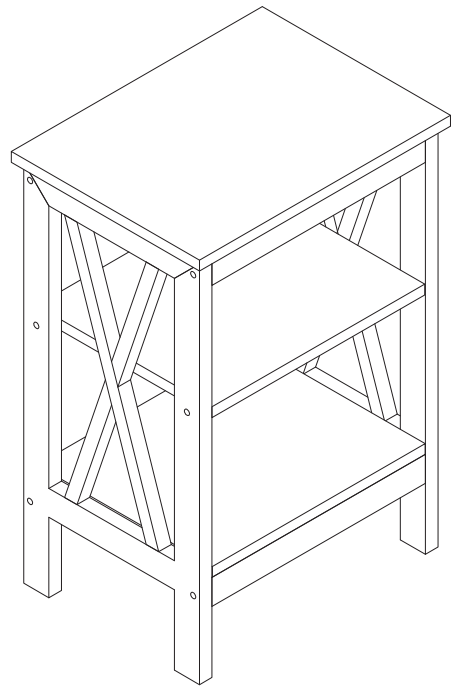

Modello NO: GYZN-NO.1

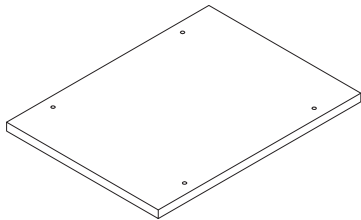
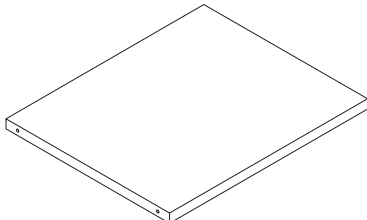
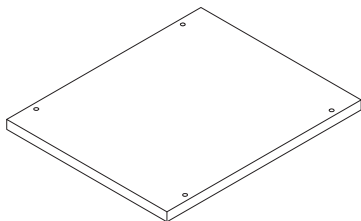
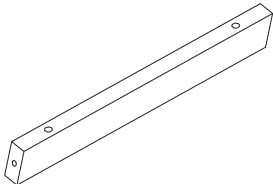
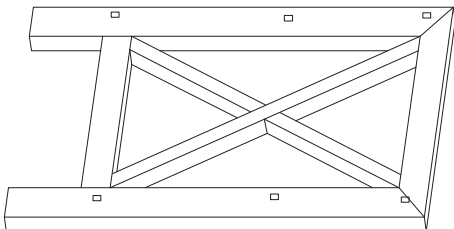

Components / Bauteile / Composants / Componenti / Componentes /

1	 <p data-bbox="1105 339 1317 376">400×300mm</p>	1
2	 <p data-bbox="1105 610 1317 647">339×280mm</p>	1
3	 <p data-bbox="1105 877 1317 913">339×280mm</p>	1
4	 <p data-bbox="1062 1134 1312 1170">20×40×340mm</p>	4
5	 <p data-bbox="1094 1400 1305 1437">584×280mm</p>	2

Screws & Tools / Schrauben und Werkzeuge / Vis et outils / Viti e utensili / Tornillos y Herramientas /

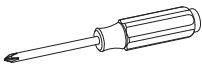
B	 <p data-bbox="1105 1662 1300 1699">M5x50mm</p>	4
G	 <p data-bbox="1105 1823 1300 1859">M6x40mm</p>	8
I	 <p data-bbox="1105 1983 1300 2020">M6x50mm</p>	8
		1

Step 1

G

M6x40mm
8PCS

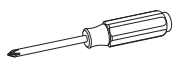

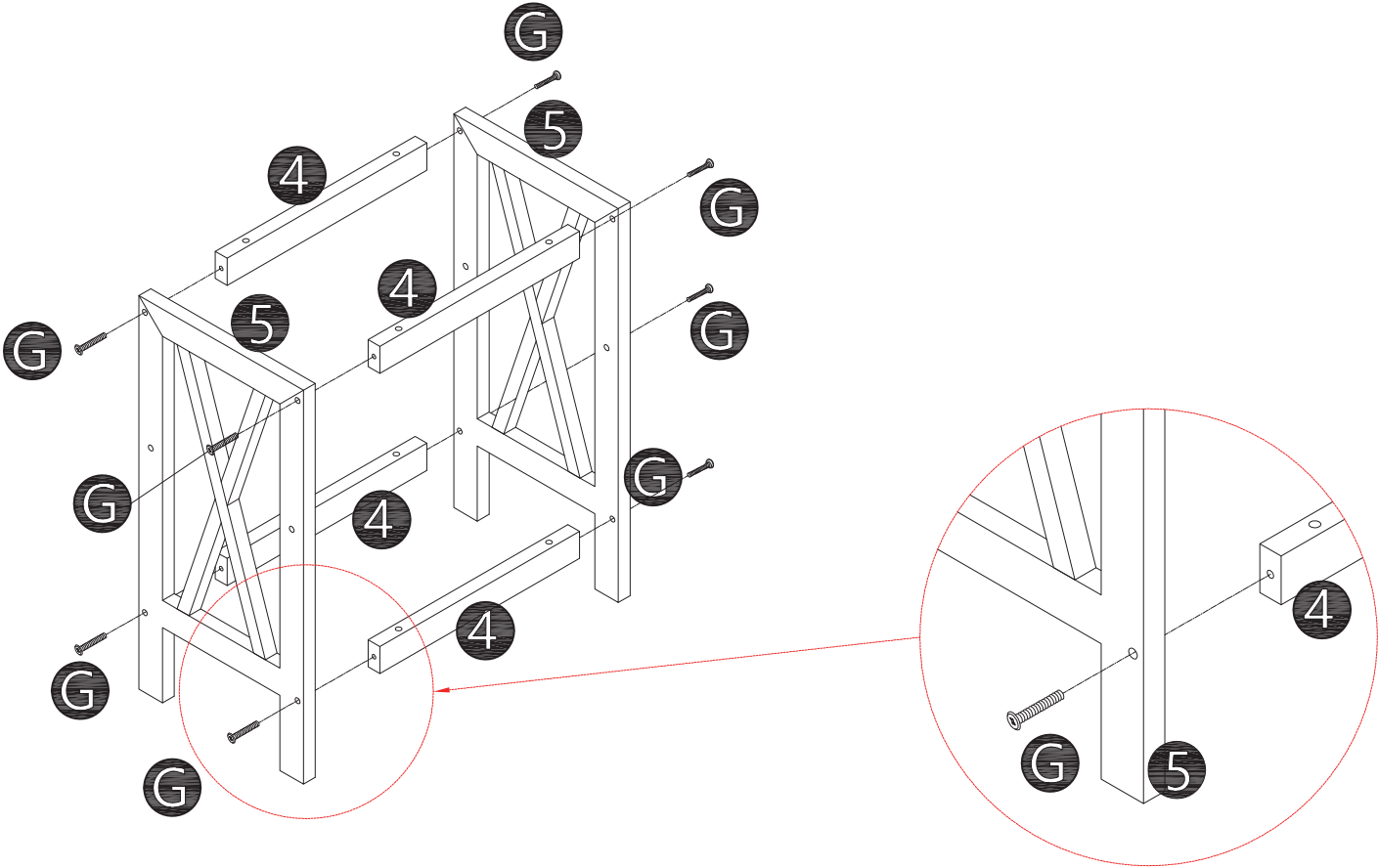
1PC

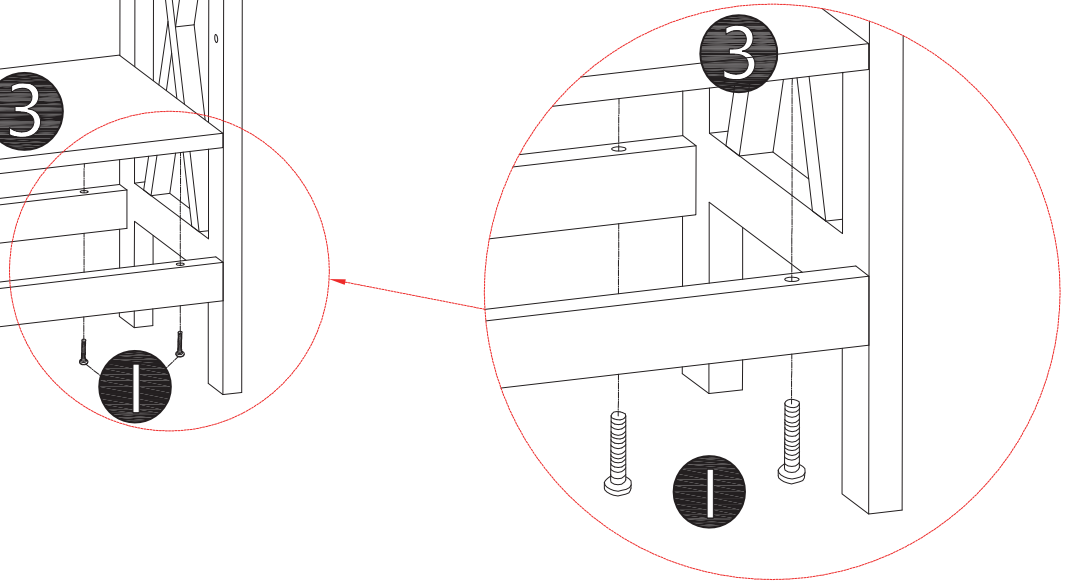
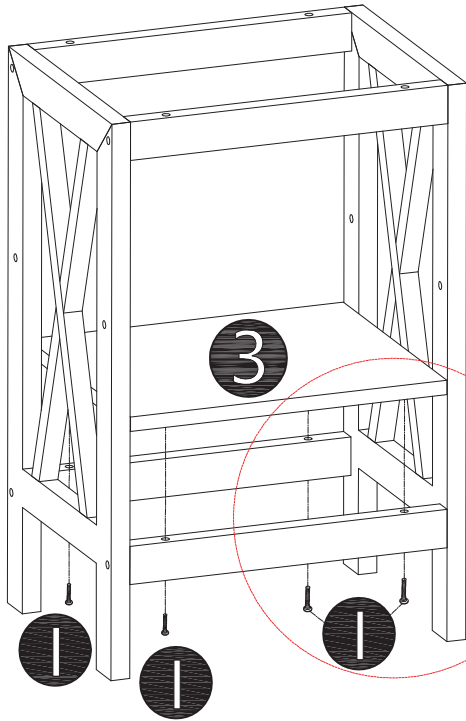
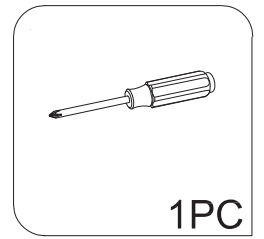

Step 1

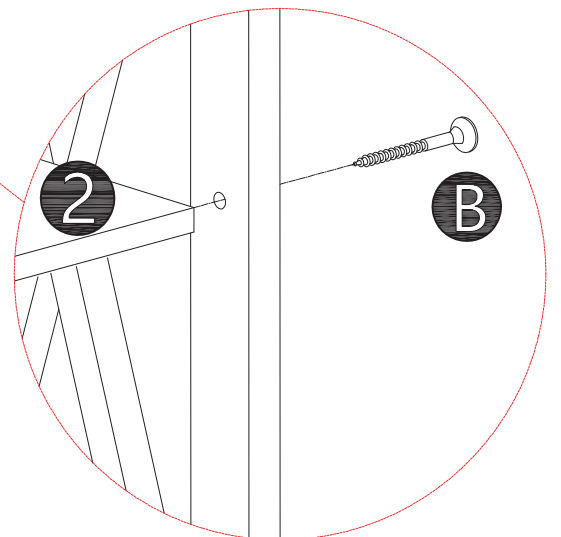
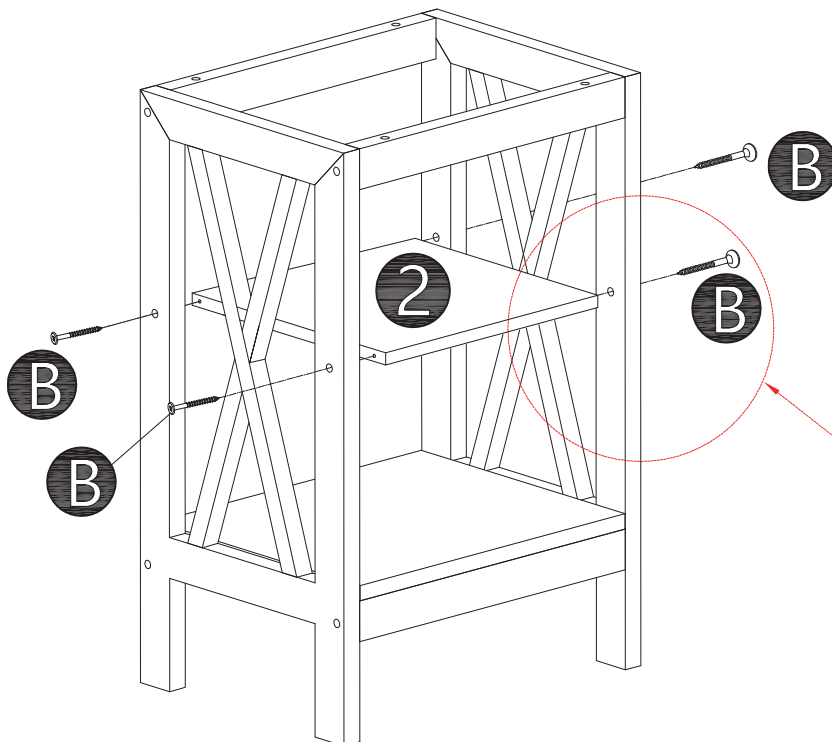
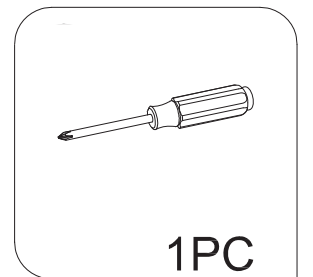
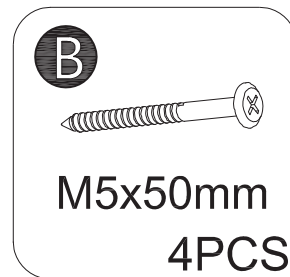

Step 3



Step 4

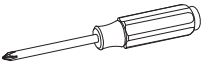

M6x50mm
4PCS

1PC

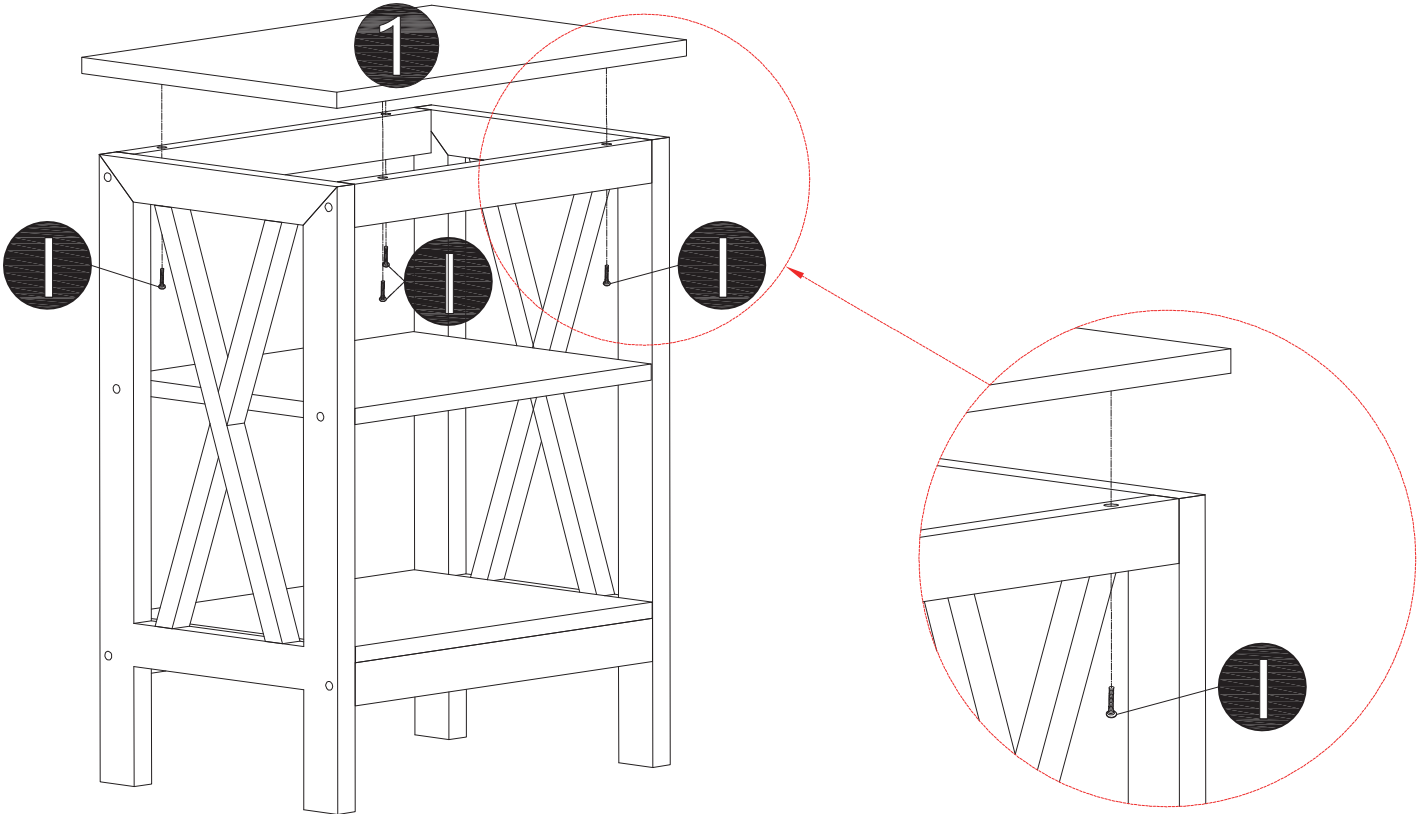

Step 5

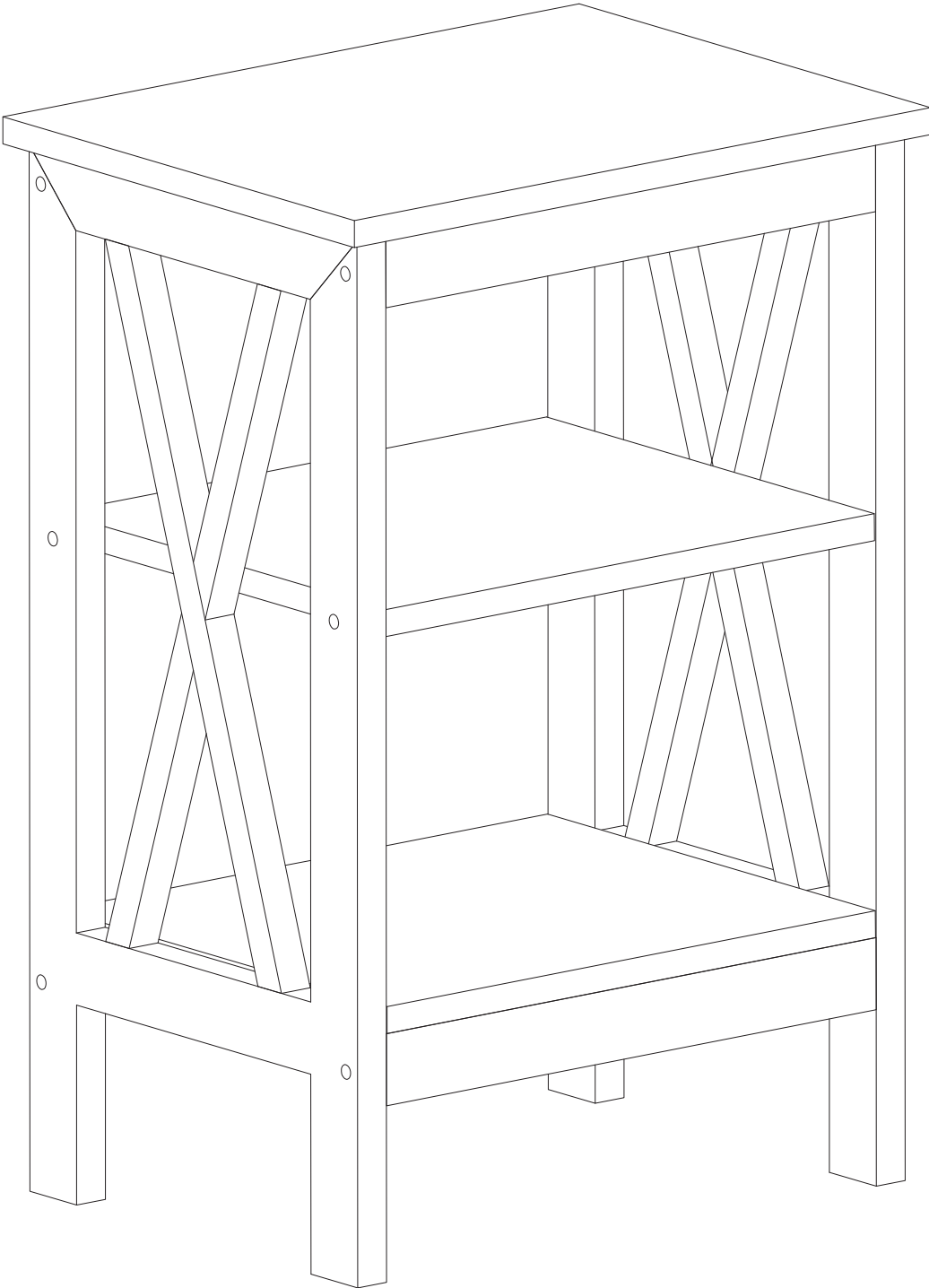

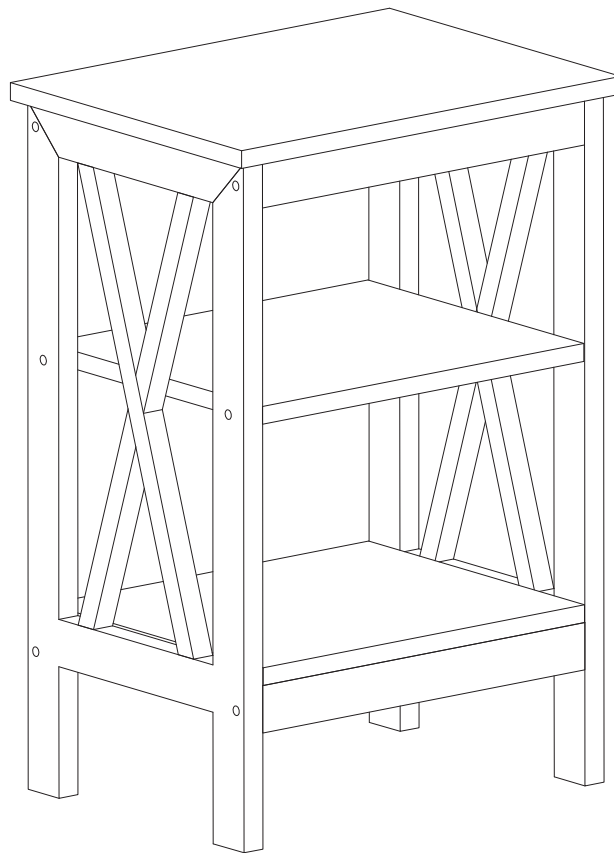

CONTACT US
KONTAKTIEREN SIE UNS
NOUS CONTACTER
CONTATTACI
CONTÁCTENOS



Tel: +1 (570) 530-2113

E-mail: support@vecelo.com (US/CA)

E-mail: support-euteam@vecelo.com (EU/FR/DE/ES/IT)

Website: www.vecelo.com