

# 三抽床头柜

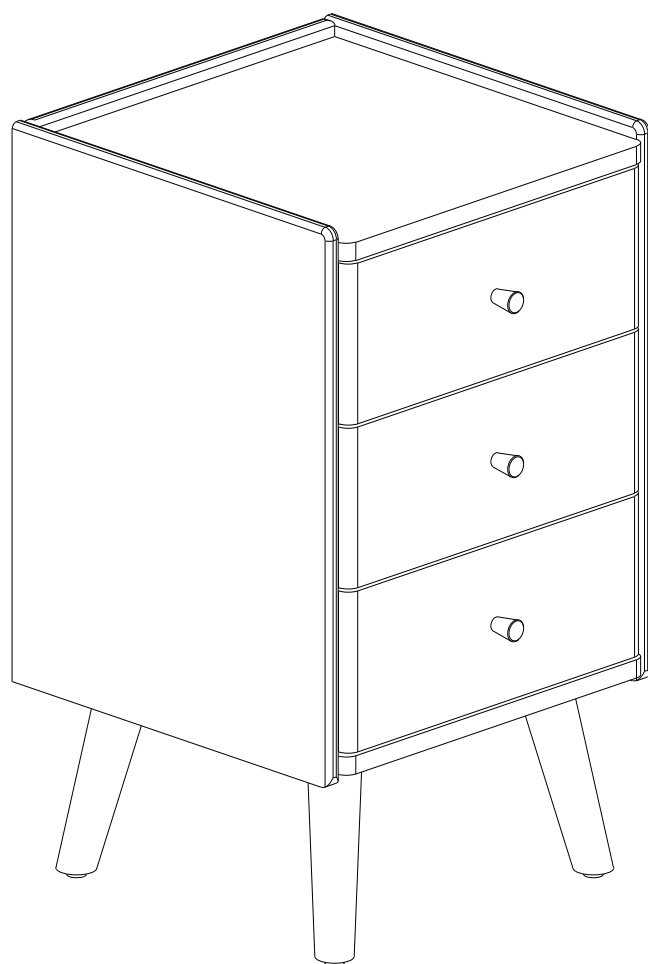

# 安装示意图

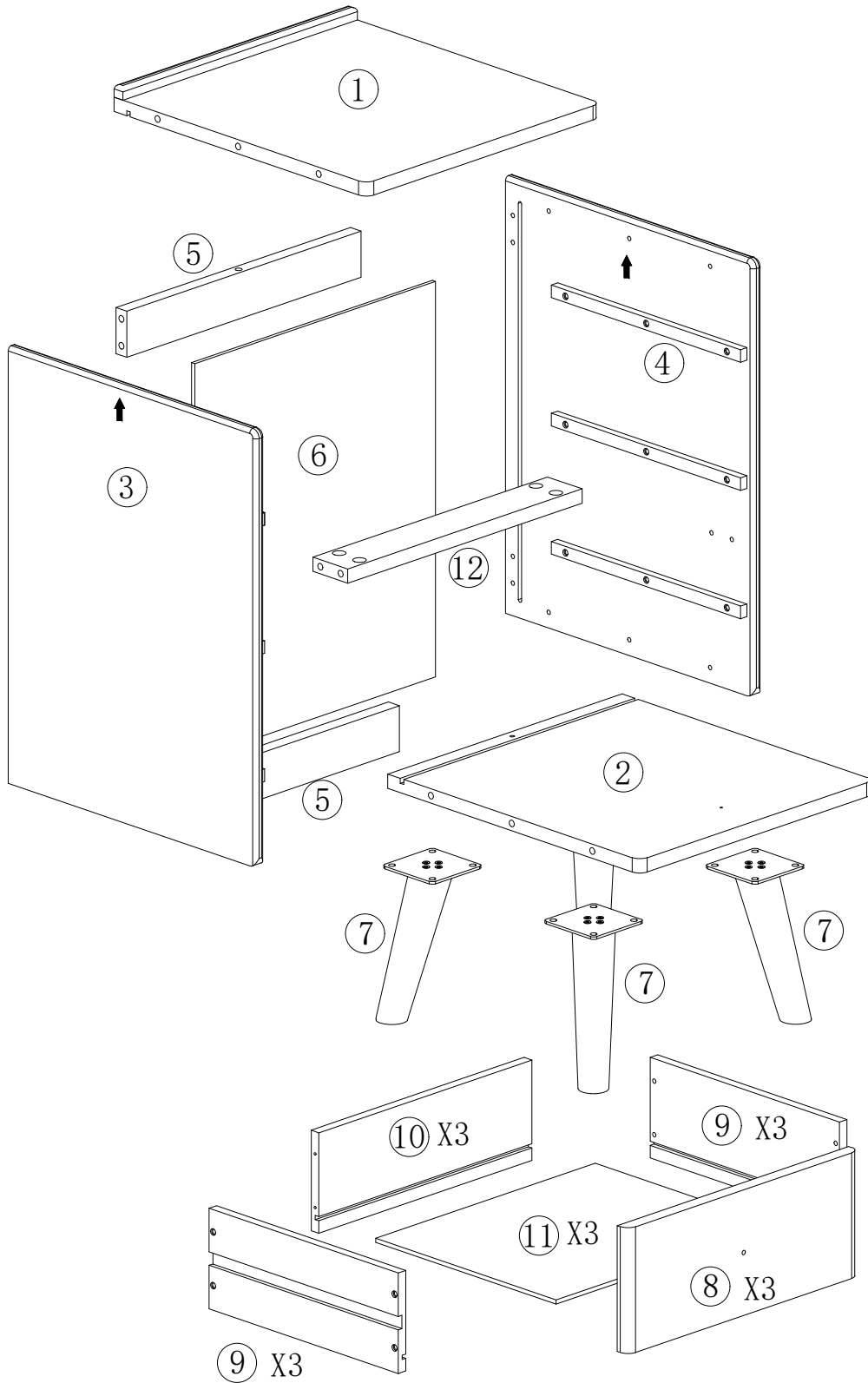

# 部件表

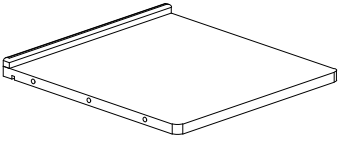
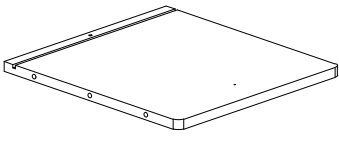
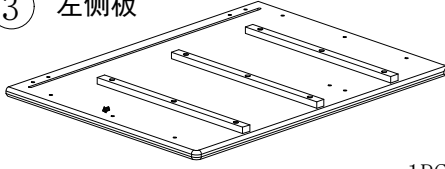
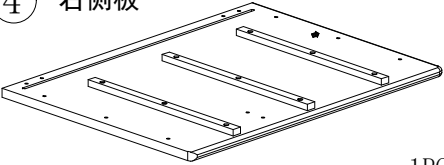
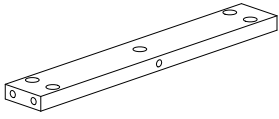
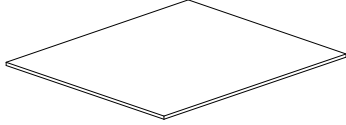
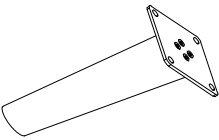
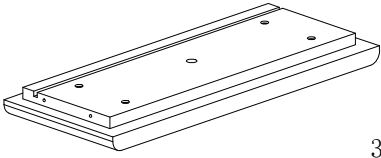
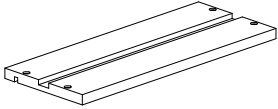
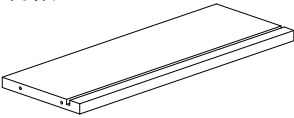
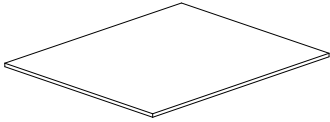
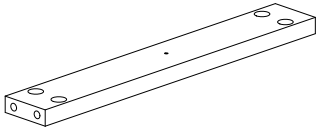
① 面板  1PC	② 底板  1PC	③ 左侧板  1PC
④ 右侧板  1PC	⑤ 后上/后下横条  2PCS	⑥ 背板  1PC
⑦ 车枳脚  4PCS	⑧ 抽面与抽前组合  3PCS	⑨ 抽侧板  6PCS
⑩ 抽后板  3PCS	⑪ 抽底板  3PCS	⑫ 抽屉下横条  1PC

# 注意

用合适的螺丝能预防损坏这些组件

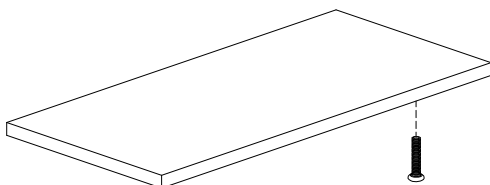

示例

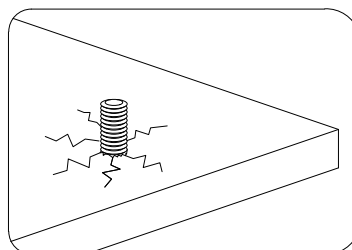

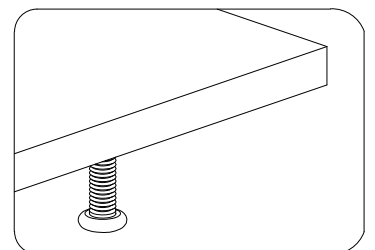

错误：螺丝会导致木板裂开

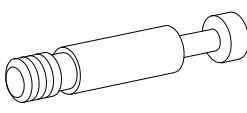

正确：螺丝是正确尺寸

# 五金表

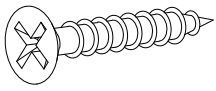
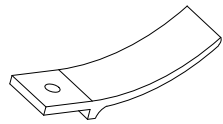
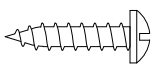
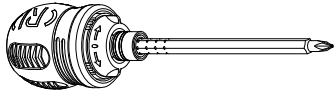
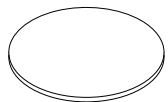
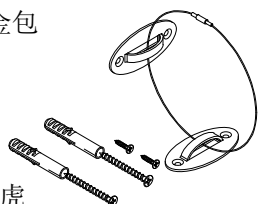
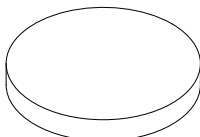
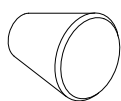
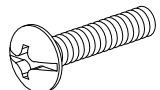
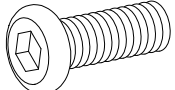
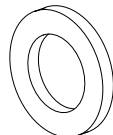
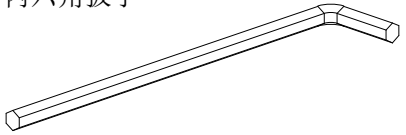
<p><b>A</b> 二合一螺杆</p>  <p>L=40MM                      26+2PCS</p>	<p><b>B</b> 二合一锁柄</p>  <p>15*11MM                      26+2PCS</p>	<p><b>C</b> 平头快速牙</p>  <p>#8*30MM                      24+2PCS</p>
<p><b>D</b> 抽档片</p>  <p>L=50MM                      3PCS</p>	<p><b>E</b> 伞头木螺丝</p>  <p>#3.5*15MM                      3PCS</p>	<p><b>F</b> 十字螺丝刀</p>  <p>M6*136MM                      1PC</p>
<p><b>G</b> 环美贴</p>  <p>20MM                      10+1PCS</p>	<p><b>H</b> 防倒五金包</p>  <p>含螺丝/壁虎                      1PC</p>	<p><b>I</b> 不织布垫</p>  <p>30*3MM                      4PCS</p>
<p><b>J</b> 锥形拉手</p>  <p>20*23MM                      3PCS</p>	<p><b>K</b> 十字大扁头螺杆</p>  <p>M4*32MM                      3PCS</p>	<p><b>L</b> 内六角螺杆</p>  <p>M6*15MM                      16+2PCS</p>
<p><b>M</b> 平垫片</p>  <p>M6*13MM                      16+2PCS</p>	<p><b>N</b> 内六角扳手</p>  <p>M4*100MM                      1PC</p>	

## 多合一棘轮螺丝刀使用说明书

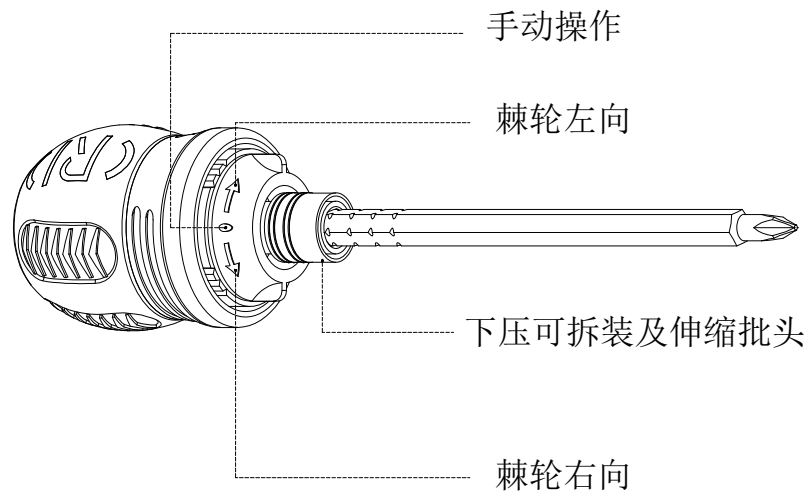

# How to use the cam lock system

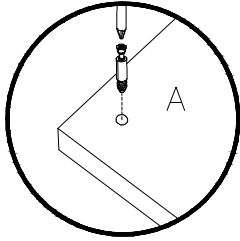

**1. Screw cam bolt into panel**

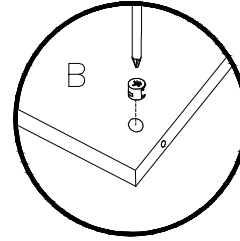

**2. Push cam into panel - arrow feature on cam top points to panel edge**

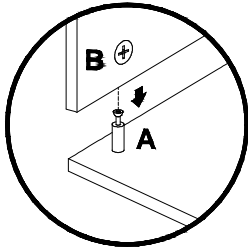

**3. Align cam bolt(s) with cam(s) and insert all the way into cross-bored hole(s)**

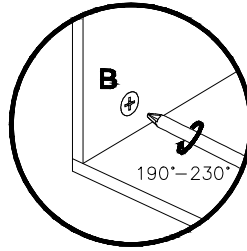

**4. Rotate cam(s) clockwise 190°-230° to lock panels together**

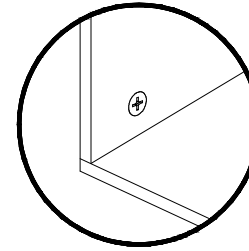

**5. Panels should be tight against each other and connection should be rigid**

**Insert the wood dowel (A) at least half way by tapping lightly with a rubber mallet, IF NECESSARY**

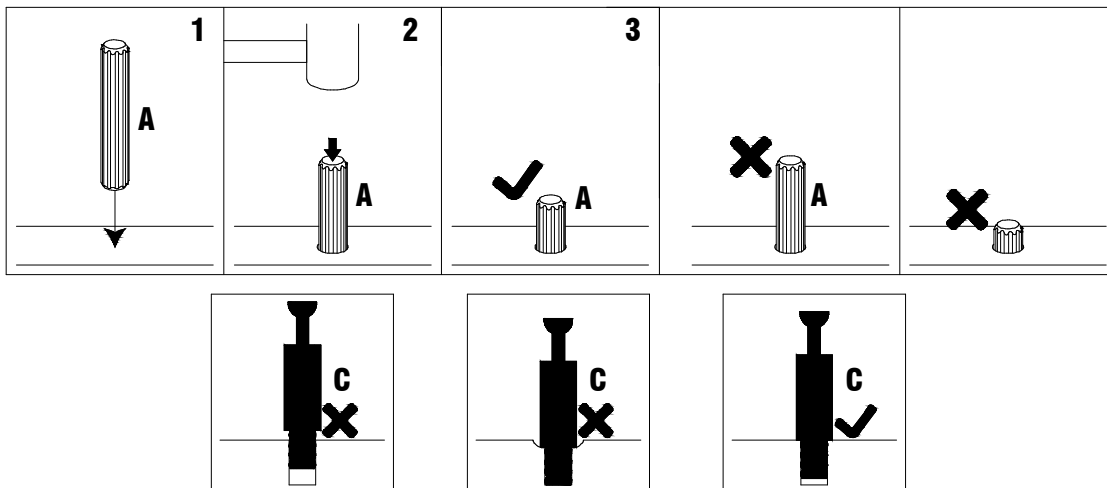



## **⚠ WARNING**

- Unit must be placed on a level surface or leveled with included hardware (when applicable).
- Do not sit or stand on or allow children to climb, sit or stand on the assembled product.
- For safety reasons, it is imperative that this unit be mounted to the wall.
- Do not use without installing the tip restraint.
- Unit can tip over causing severe injury or death.
- Do not exceed the recommended weight limits.
- Evenly distribute the weight on each level and always keep the heavier loads on the bottom.
- Before cutting, drilling or hammering into any wall or floor surface, verify the location of electrical, plumbing and gas lines. Cutting may cause serious injury.

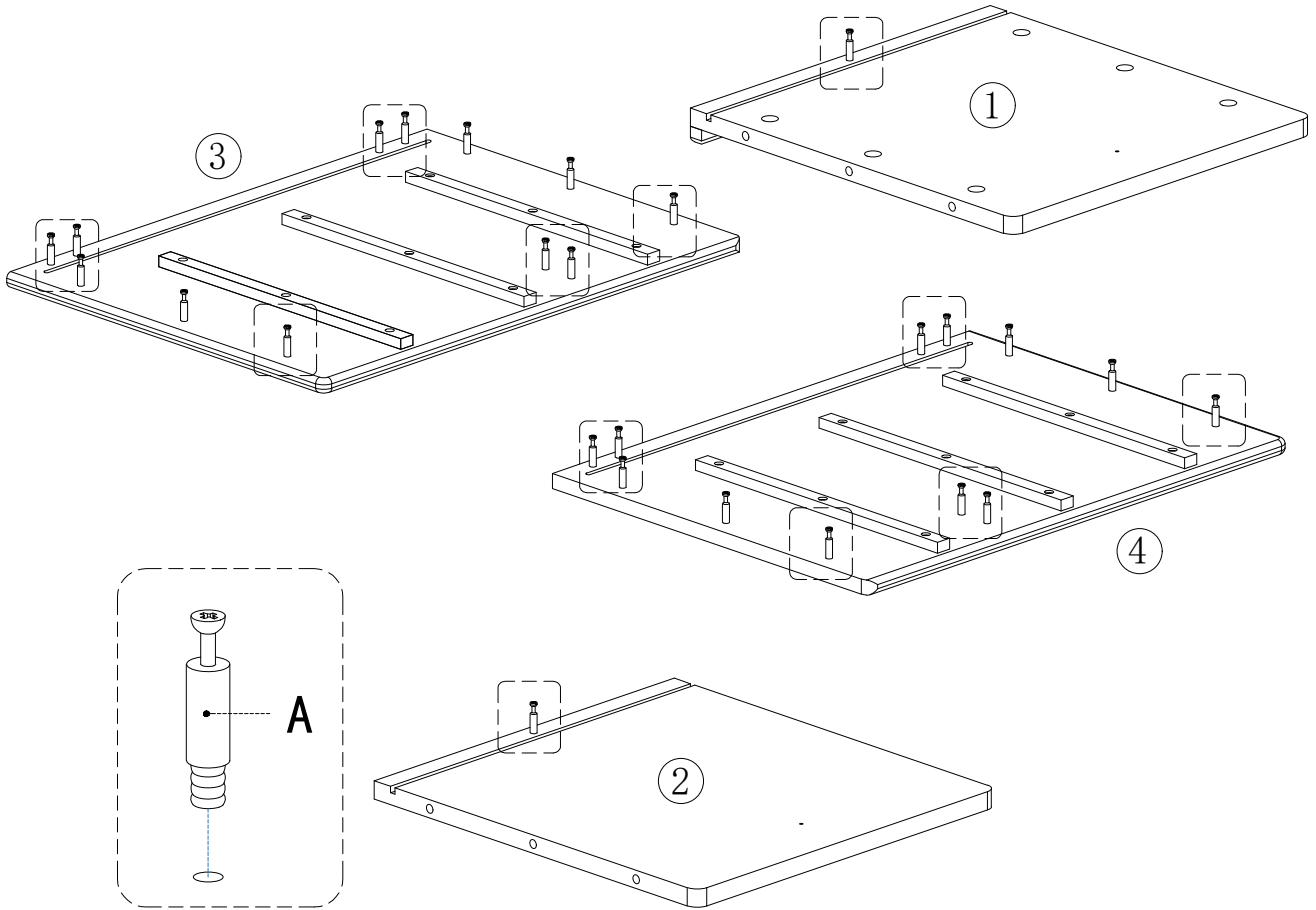
## Step 1





►如图：将五金A用工具F固定在部件1/2/3/4上。

A	 L=40MM	26PCS
F	 M6*1.36MM	1PC

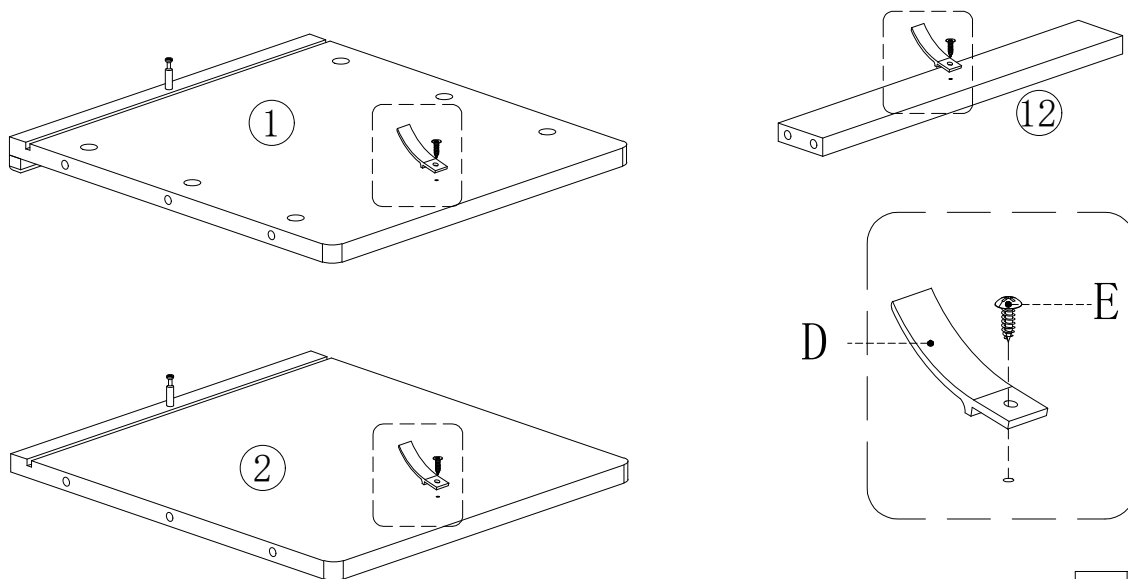
## Step 2





►如图：将五金D/E用工具F固定在1/2/12部件上。

D	 L=50MM	3PCS
E	 #3. 5*15MM	3PCS
F	 M6*1.36MM	1PC

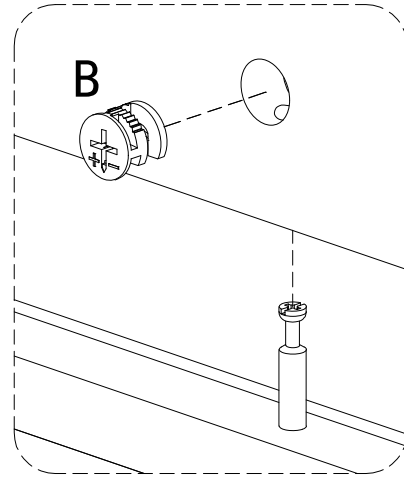
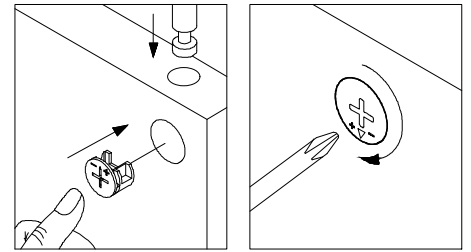
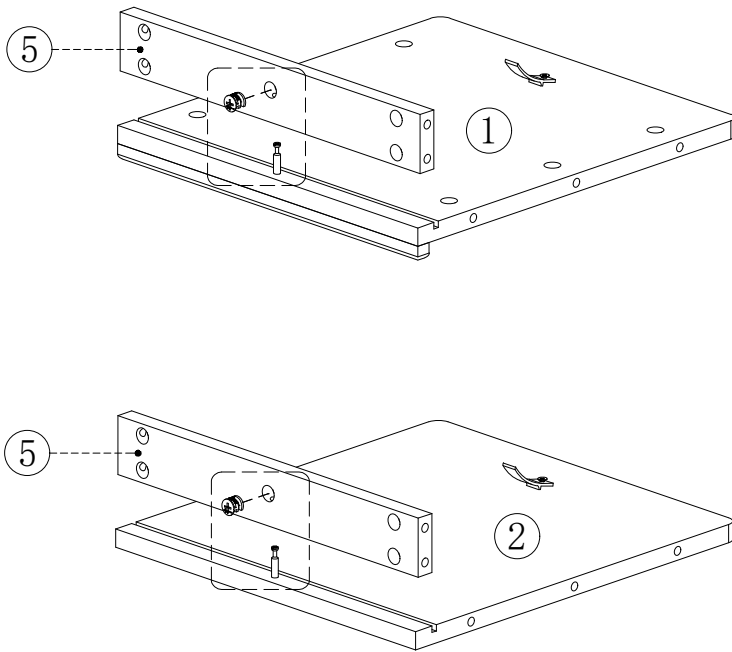
### Step 3





►如图:用五金B/F将部件1/5;2/5连接在一起。

B		15*9MM	2PCS
F		M6*136MM	1PC

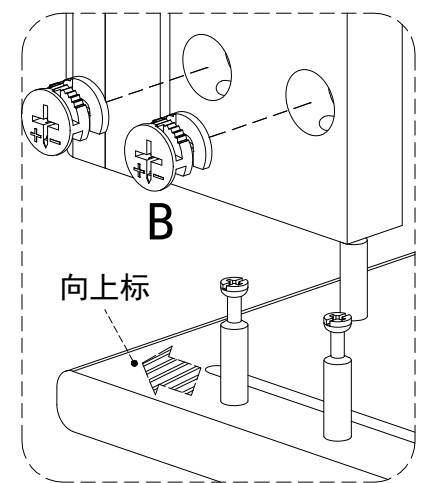
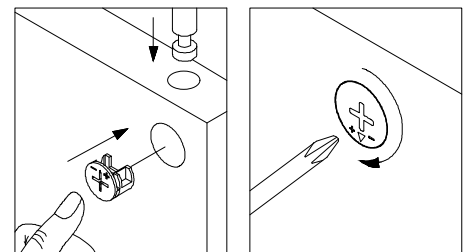
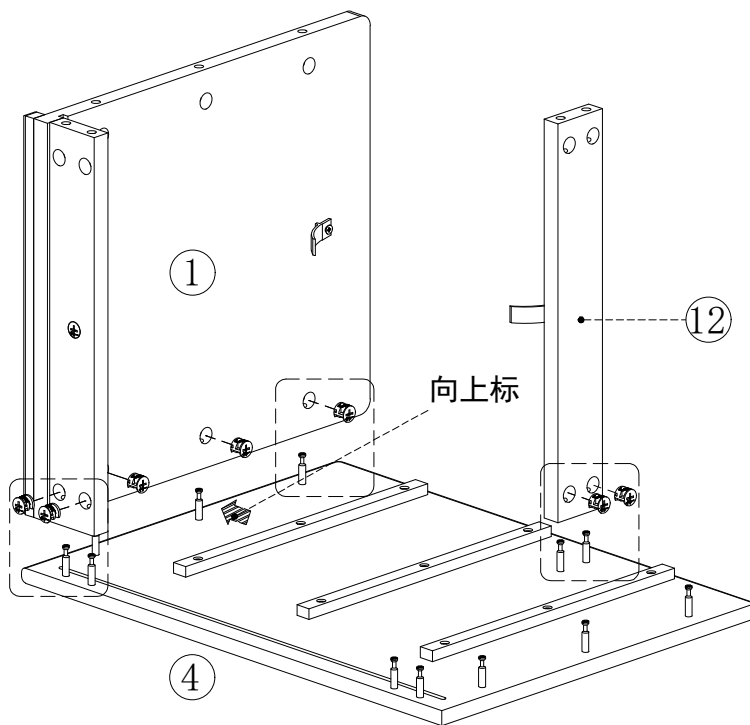
### Step 4





►如图:用五金B/F将部件Step3组好的部件和部件4/12连接在一起。

B		15*9MM	7PCS
F		M6*136MM	1PC

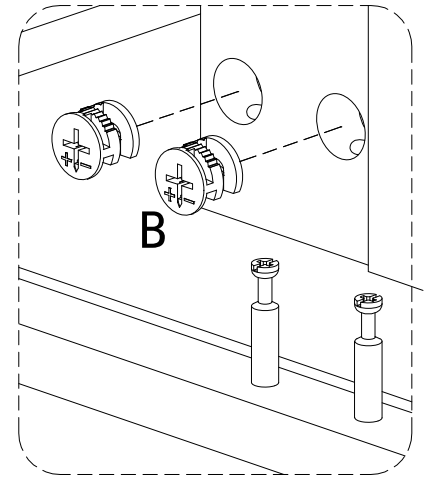
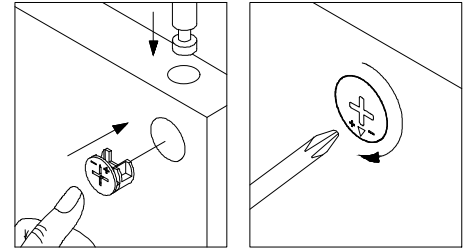
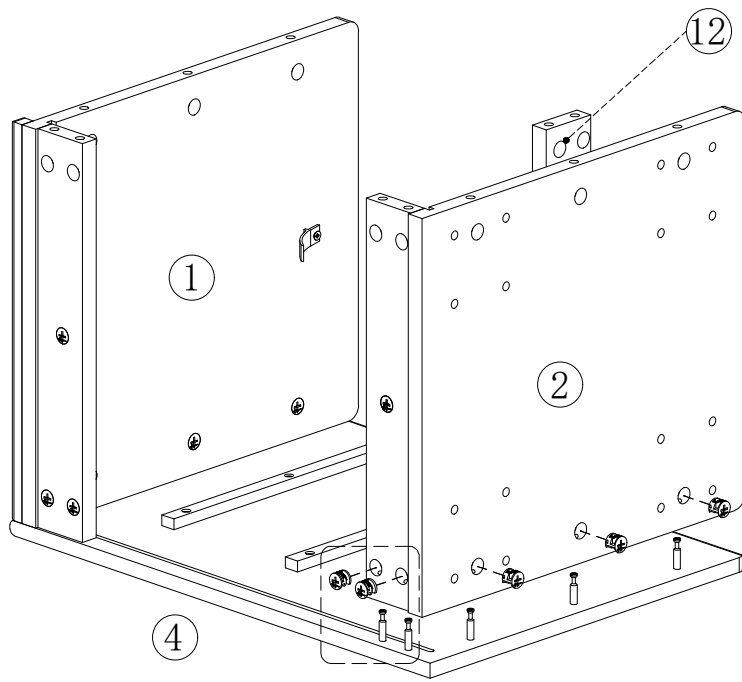
## Step 5



►如图:用五金B/F将部件Step4组好的部件和部件2连接在一起。

<b>B</b>		15*9MM	5PCS
<b>F</b>		M6*136MM	1PC

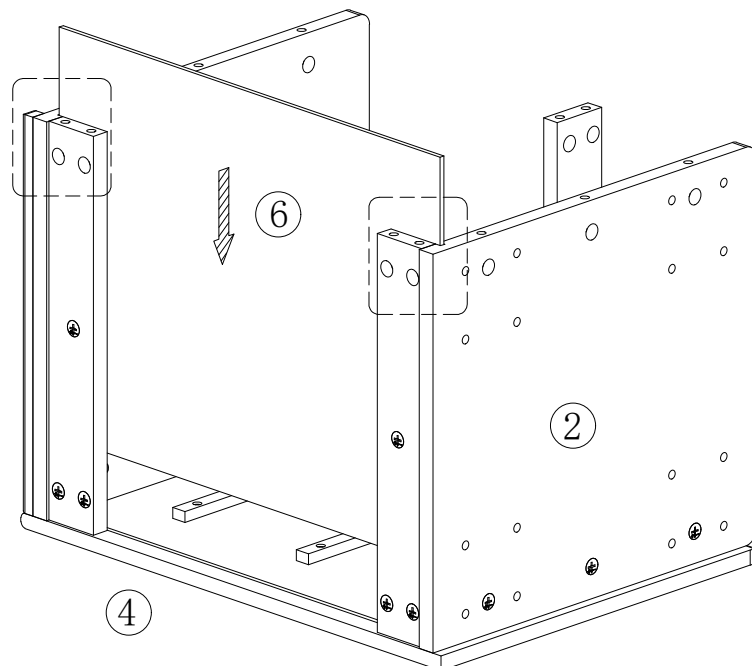
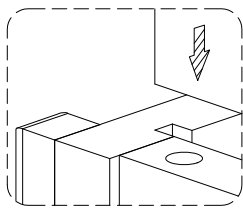

## Step 6

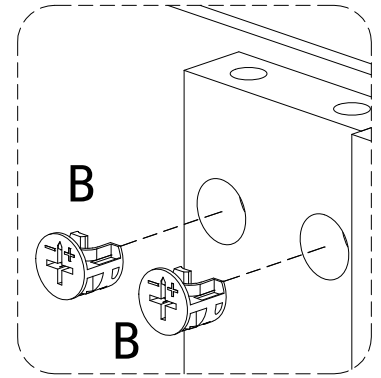
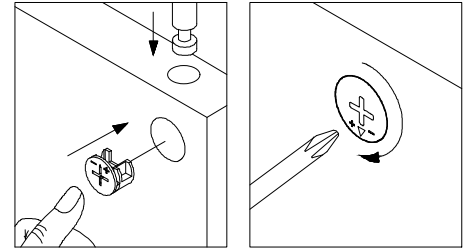
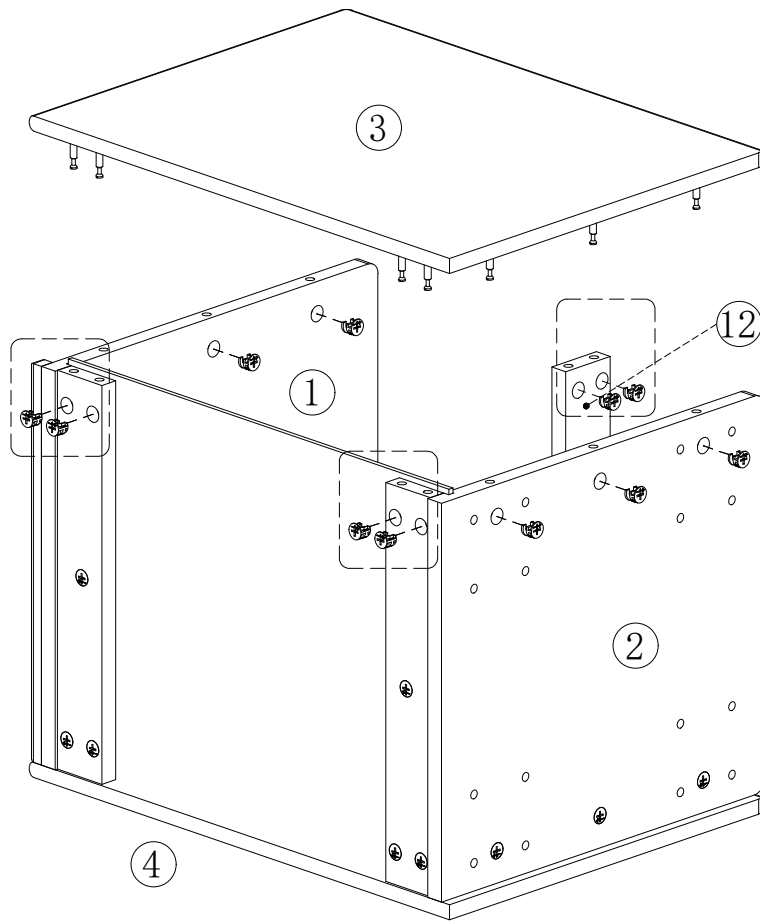

►如图:将部件6插入Step5组好的部件。

### Step 7



<b>B</b>		15*9MM	12PCS
<b>F</b>		M6*136MM	1PC

►如图：用五金B/F将部件3和Step6组好的部件组装。

### Step 8

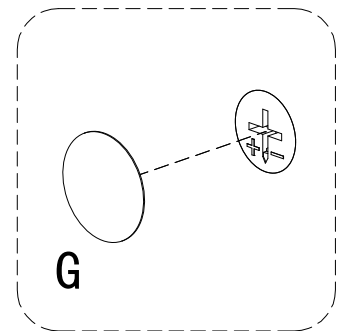
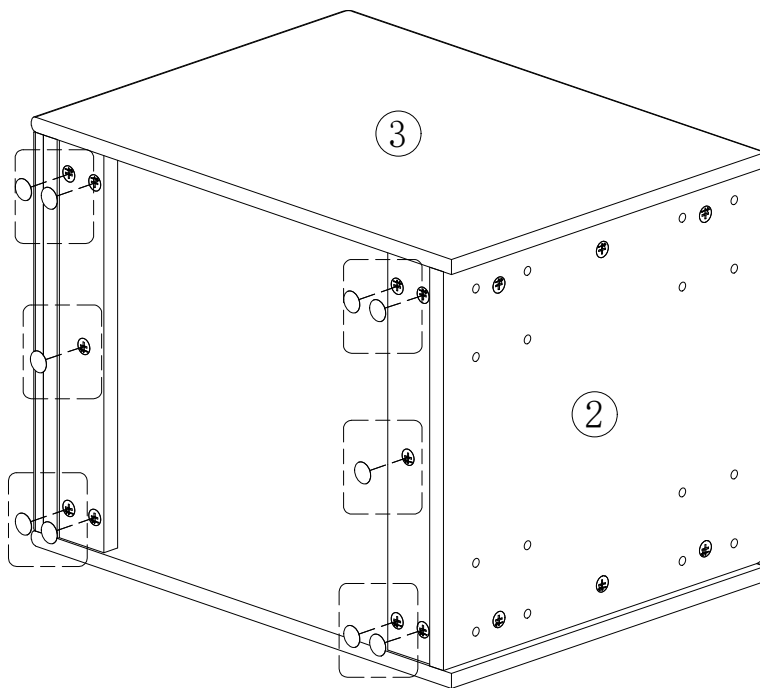



►如图：将Step6组好的部件中如图所示的孔用五金G盖住。

<b>G</b>		20MM	10PCS
----------	---	------	-------

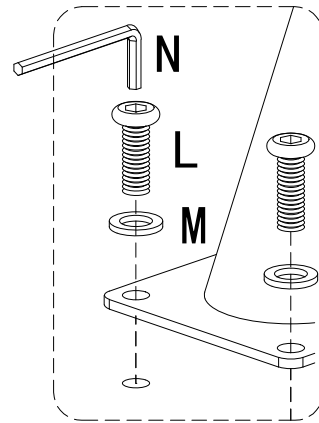
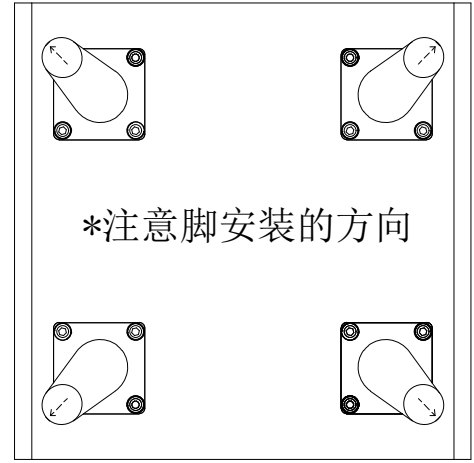
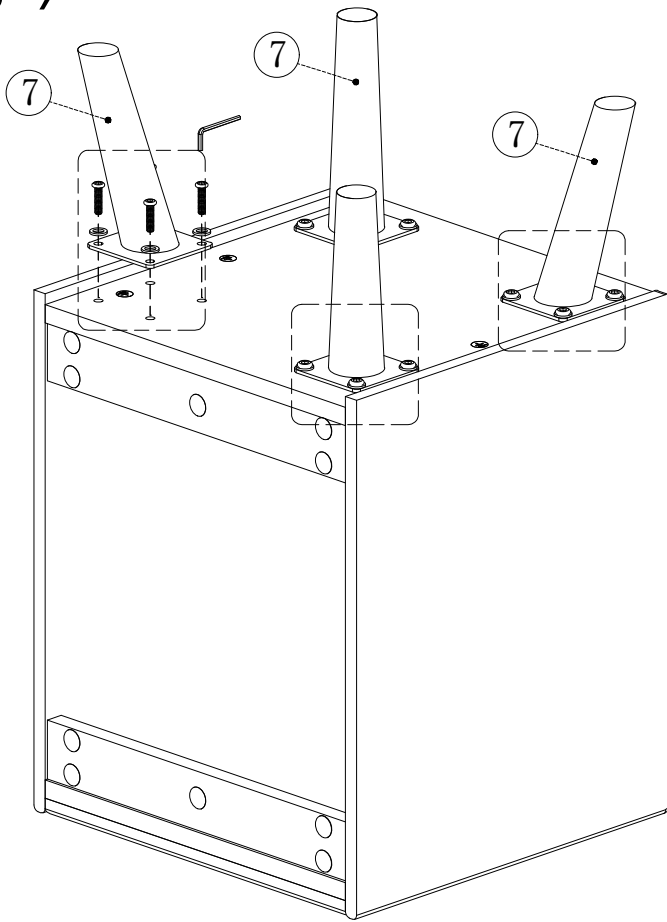
### Step 9



L	 M6*12MM	16PCS
M	 M6*13MM	16PCS
N	 M4*100MM	1PC

▶如图：用五金L/M/N将部件7和Step8组好的部件组装。

### Step 10

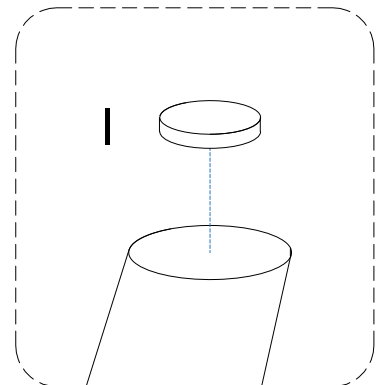
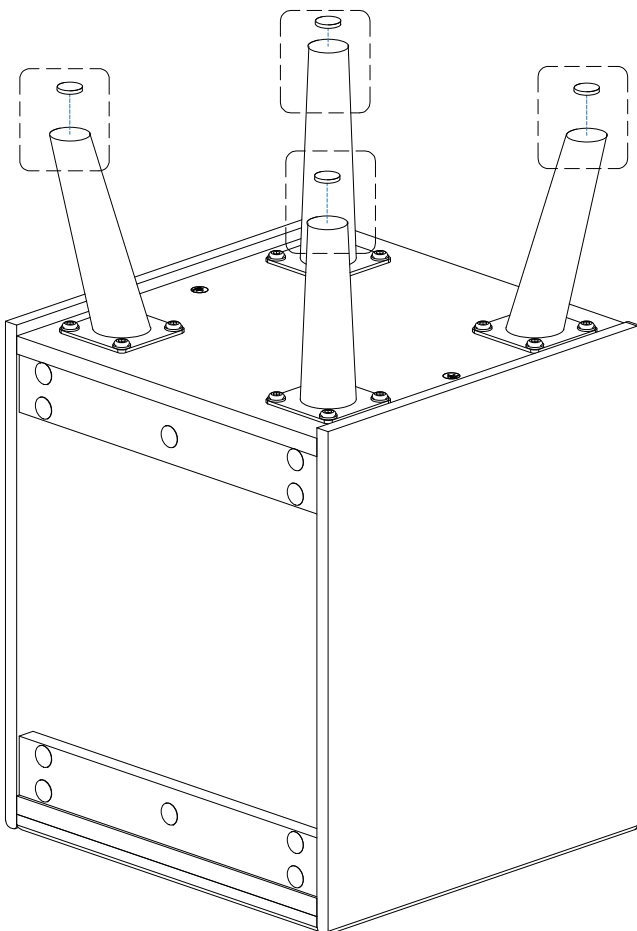

▶如图：将五金I粘在7号部件底部。



I	 25*3MM	4PCS
---	---	------

### Step 11

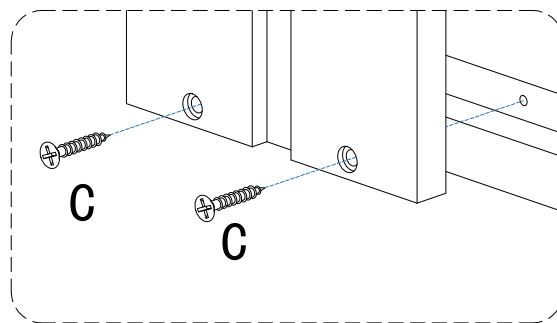
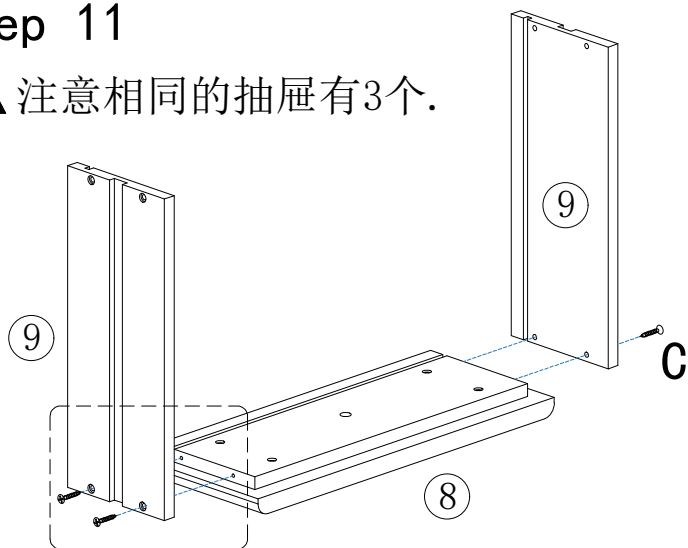
▲注意相同的抽屉有3个。



如图，用五金C/F将部件8/9连接在一起。

C	 #8*25MM	12PCS
F	 M6*136MM	1PC

### Step 12

▲注意相同的抽屉有3个。

将部件11插入Step11组好的部件。

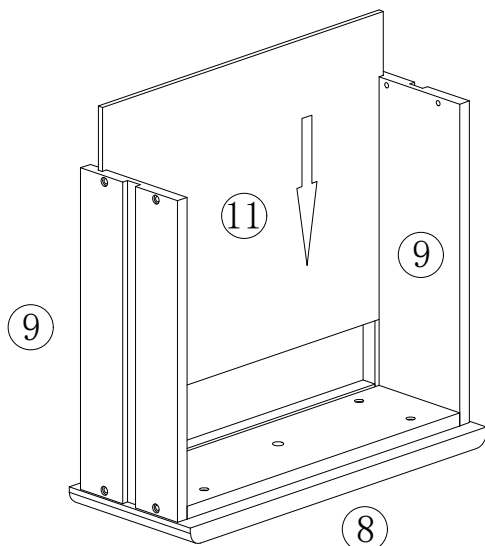

### Step 13



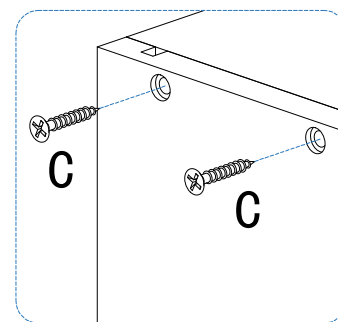
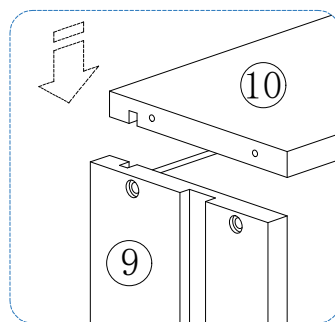

▲注意相同的抽屉有3个。

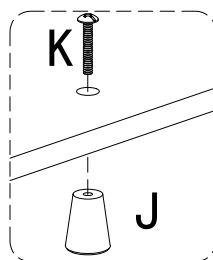
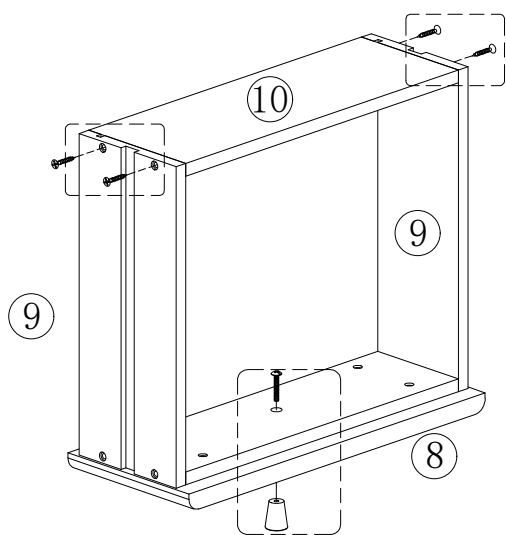

如图，用五金C/F将部件9/10连接在一起。



将五金J/K组装在8号部件上

C	 #8*25MM	12PCS
F	 M6*136MM	1PC
J	 20*23MM	3PCS
K	 M4*32MM	3PCS

### Step 14

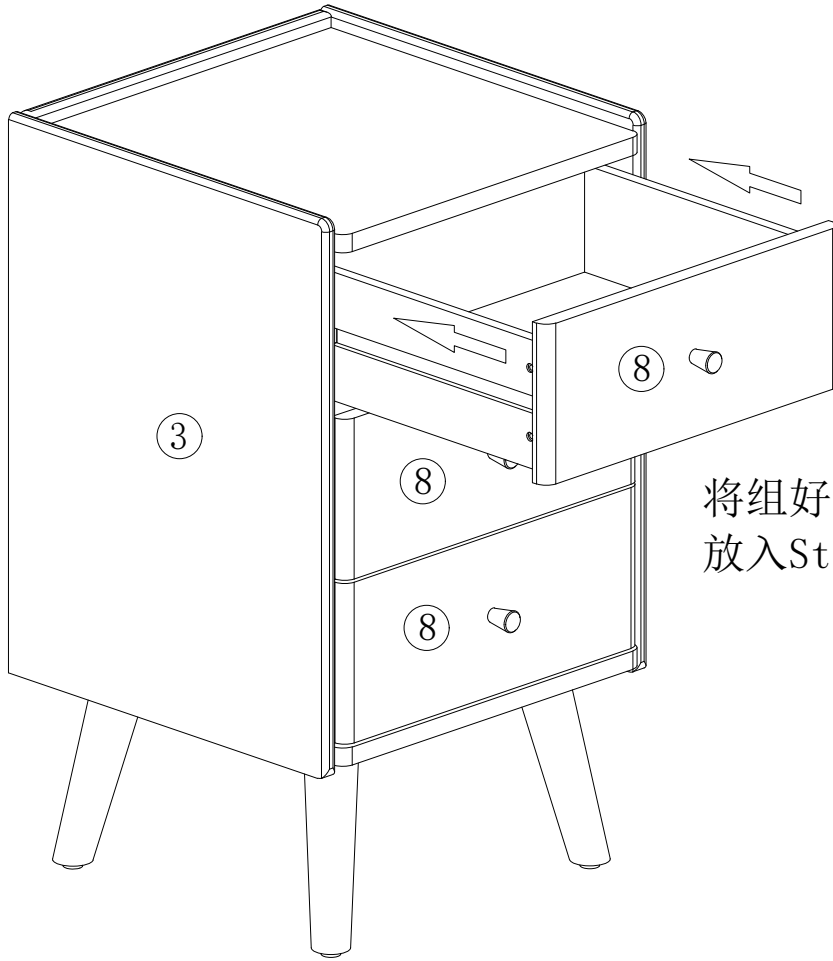

将组好的抽屉  
放入Step10组好的柜子内。

### Step 15

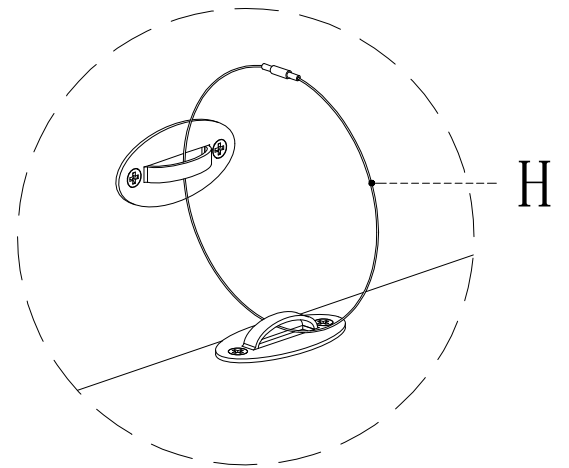
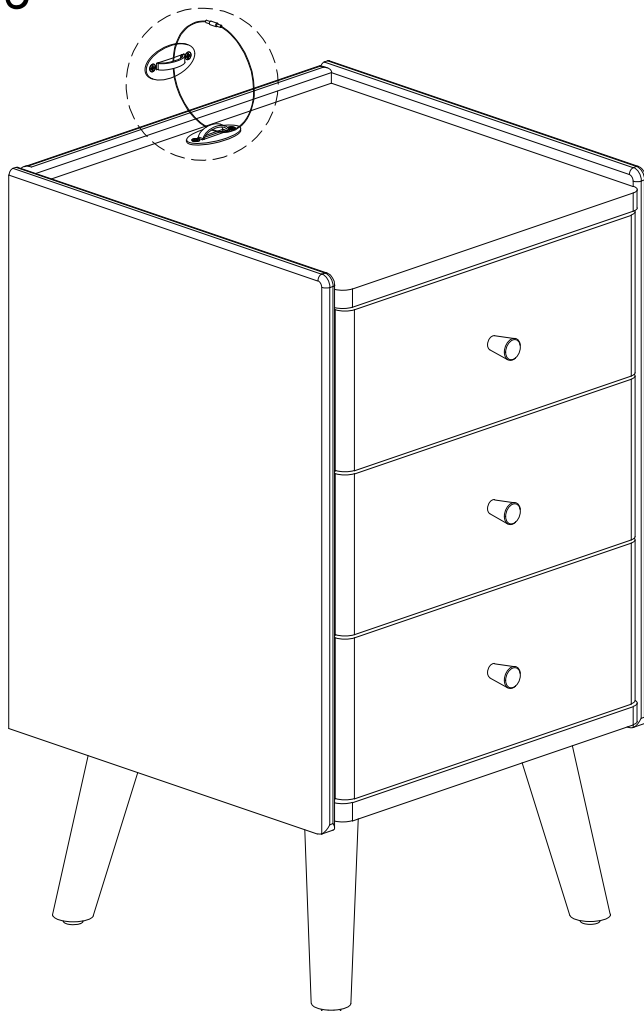

用五金H将Step14组好的部件  
固定在墙上。