

Assembly Instructions

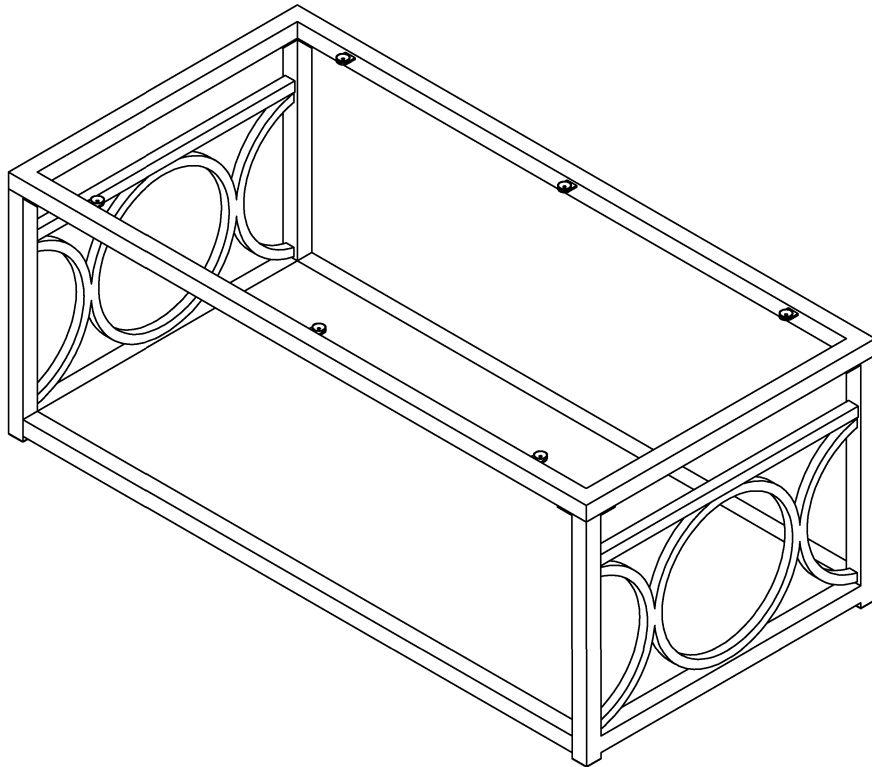

ASSEMBLY RATING

The Assembly Rating is a 5-point system that shows the degree of effort needed in assembling a specific product (with 1 being easy and 5 being difficult). For some products, two persons are recommended.

EASY  DIFFICULT

Tools Required For Assembly:

Allen Wrench

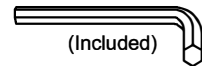

2 PERSONS RECOMMENDED

ASSEMBLY & CARE ADVICE

FOR YOUR FURNITURE TO LAST, CORRECT ASSEMBLY AND PROPER MAINTENANCE ARE NECESSARY. PLEASE FOLLOW THE INFORMATION PROVIDED BELOW TO FULLY ENJOY YOUR FURNITURE.

BASIC ASSEMBLY TECHNIQUES

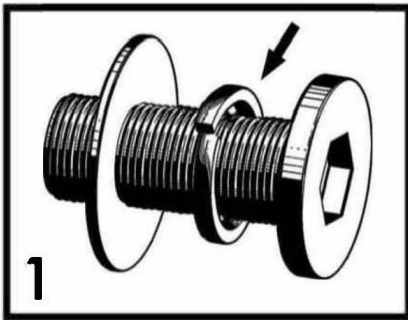

1
When lock or spring washer is used in an assembly, please make sure the lock or spring washer is placed between the larger flat washer and the head of the screw or bolt.

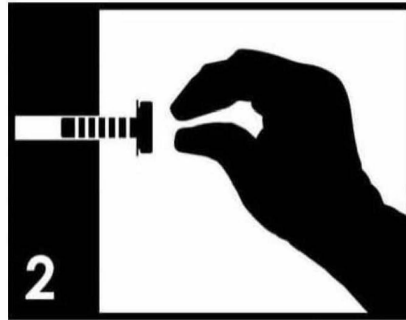

2
Position each part correctly and insert screws or bolts into their respective holes by hand tighten or using the proper hand tool. Only tighten when step is completed or when instructed to do so.

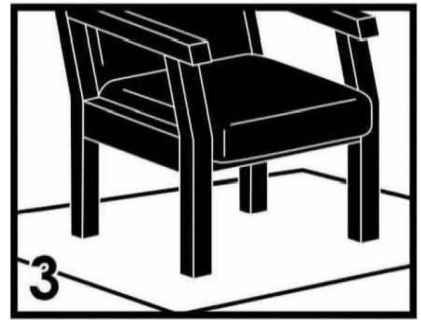

3
Use cardboard or carpet area when assembling furniture to prevent scratches. Make sure the furniture rests on a flat and level surface with each leg evenly touching the floor.

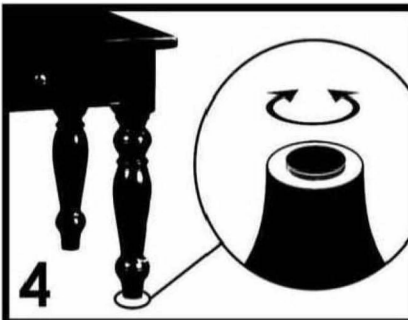

4
Some furniture comes with height adjustment knobs underneath each leg. To lower or to raise each leg, you need to turn clockwise or counterclockwise, respectively.

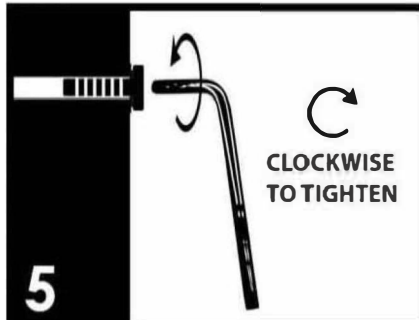

5
Make sure all parts are properly aligned, then use the appropriate hand tool to completely tighten the bolts or screws. Do not use power tools and do not overtighten.



6
Save the instructions and store the Allen wrench or any supplied tool for later maintenance. After two weeks, check and tighten any loose hardware and repeat again every six months thereafter.

IT IS THE USER'S RESPONSIBILITY TO MAINTAIN THE FURNITURE. THE HARDWARE MAY LOOSEN OVER TIME AND MAY CAUSE THE FURNITURE TO BE WOBBLY AND UNABLE TO SUPPORT ITS INTENDED WEIGHT CAPACITY. THIS MAY LEAD TO COLLAPSE AND MAY CAUSE SERIOUS INJURY.



FAILURE TO FOLLOW THE GUIDELINES ABOVE MAY RESULT IN INJURY AND/OR PROPERTY DAMAGE.

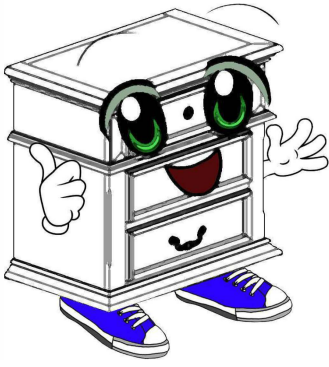

Before you begin, please read Page 2 of "Assembly and Care Advice".

And remember, do not tighten until each step is completed or instructed.

Parts List

Hardware List

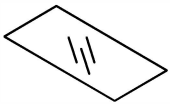

#1 x 1pc
Glass Top



#A x 16pcs
Bolt 1/4" x 1/2"

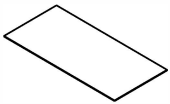

#2 x 1pc
Mirror



#B x 4pcs
Suction Cup

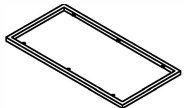

#3 x 1pc
Top Frame



#C x 4pcs
Cap 30x30mm



#4 x 4pcs
Crossbar



#D x 1pc
Allen Wench 4mm

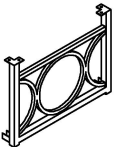

#5 x 2pcs
Side Frame



#1

1. Insert the crossbars (#4) onto the slots along the side frames (#5) and align the holes, then insert 2 bolts (#A) into each end. Secure using the Allen wrench (#D).

#A x 8pcs
#C x 4pcs

2. Insert a cap (#C) into each side frame end.

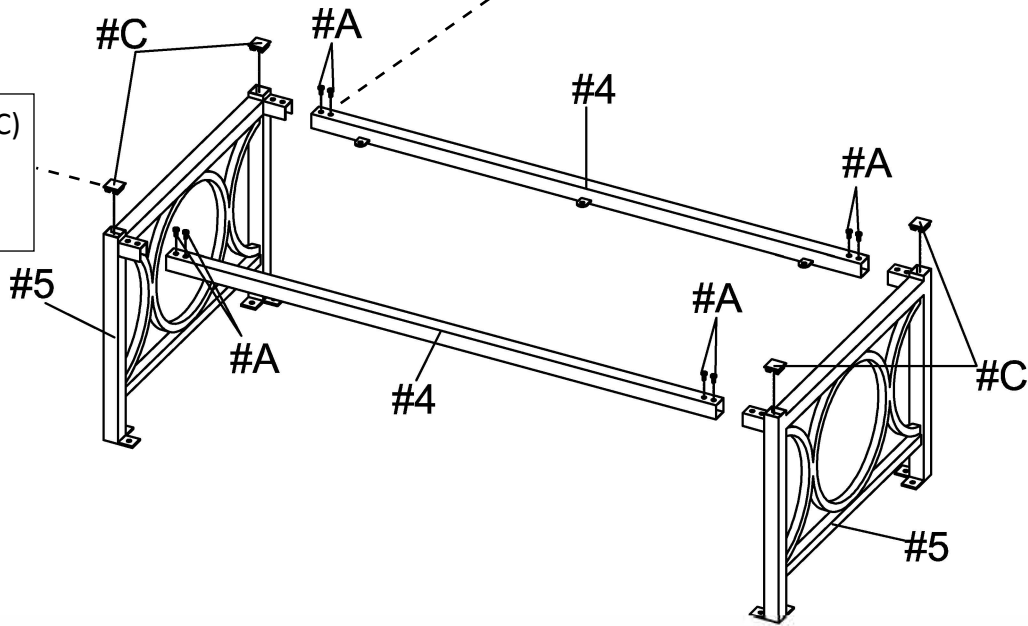

#2

2. Align the side frames (#5) face down to the holes along the top frame (#3). Insert 2 bolts (#A) into each end. Secure using the Allen wrench (D).

#A x 8pcs

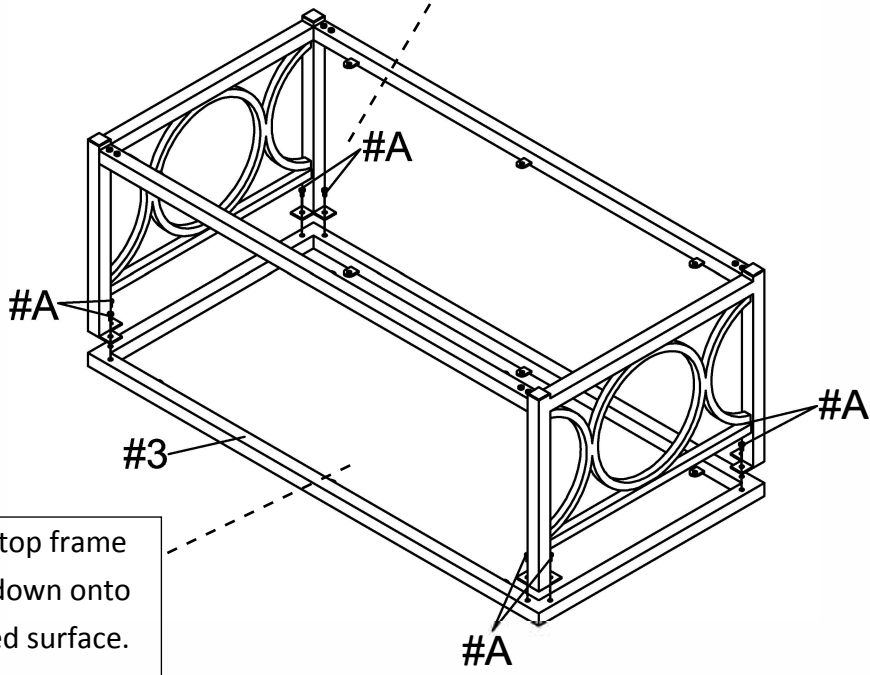

1. Place the top frame (#3) face down onto a protected surface.



#3

1. Place the suction cups (#B) into the holes along the sides of the top frame (#3), then carefully place the glass top (#1) onto those cups.

#B x 4pcs

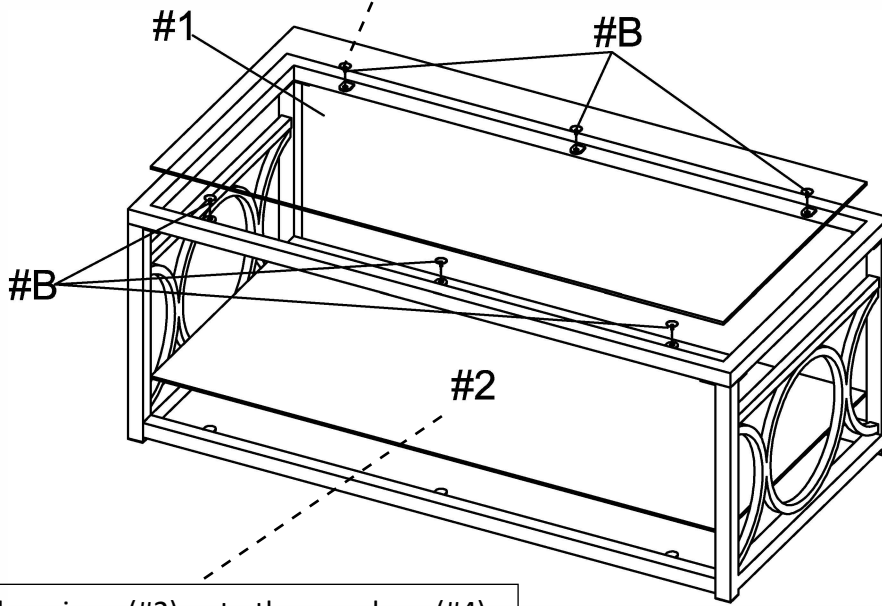

2. Place the mirror (#2) onto the crossbars (#4).



#4

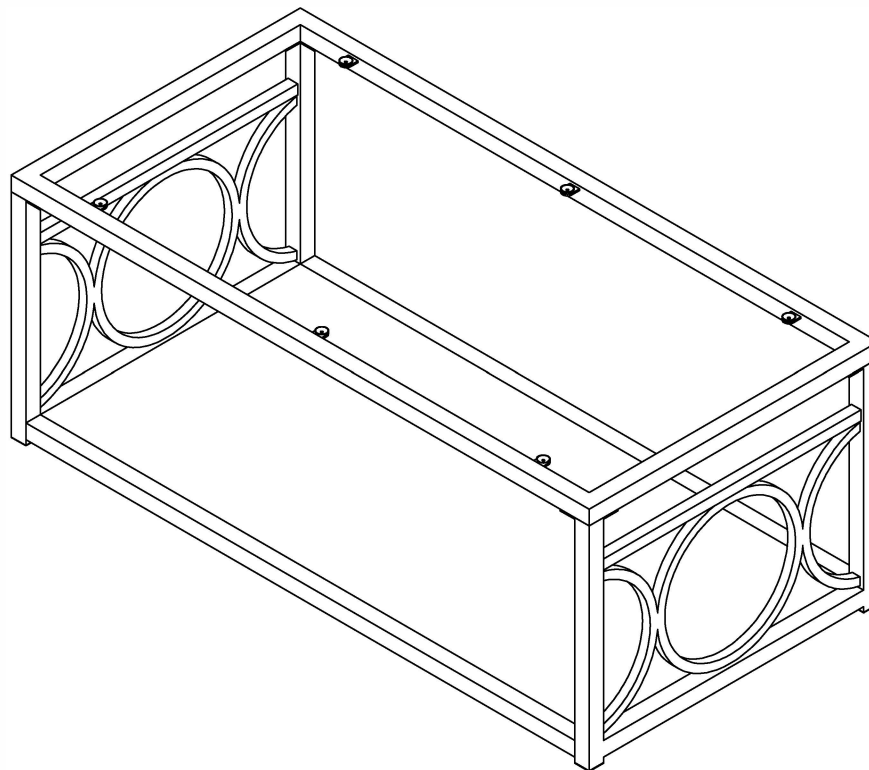

ASSEMBLY IS COMPLETED