

Thank you for purchasing your shed. No matter what size garden, a shed is the most practical of garden structures. Simply follow these step by step instructions and our top tips and you'll be enjoying your shed for many years to come. If you have any questions or need advice, our friendly team is here to help.

# SHED INSTRUCTIONS

## WORKSHOPS (8x10, 8x12, 10x10, 10x15, 10x20)

### FIXING PACKS CONTAIN:

MSFP6 - GENERAL FIXINGS  
STPK27 - TRUSS FIXINGS

MSUBPK2 - EXTRA U-BRACKETS

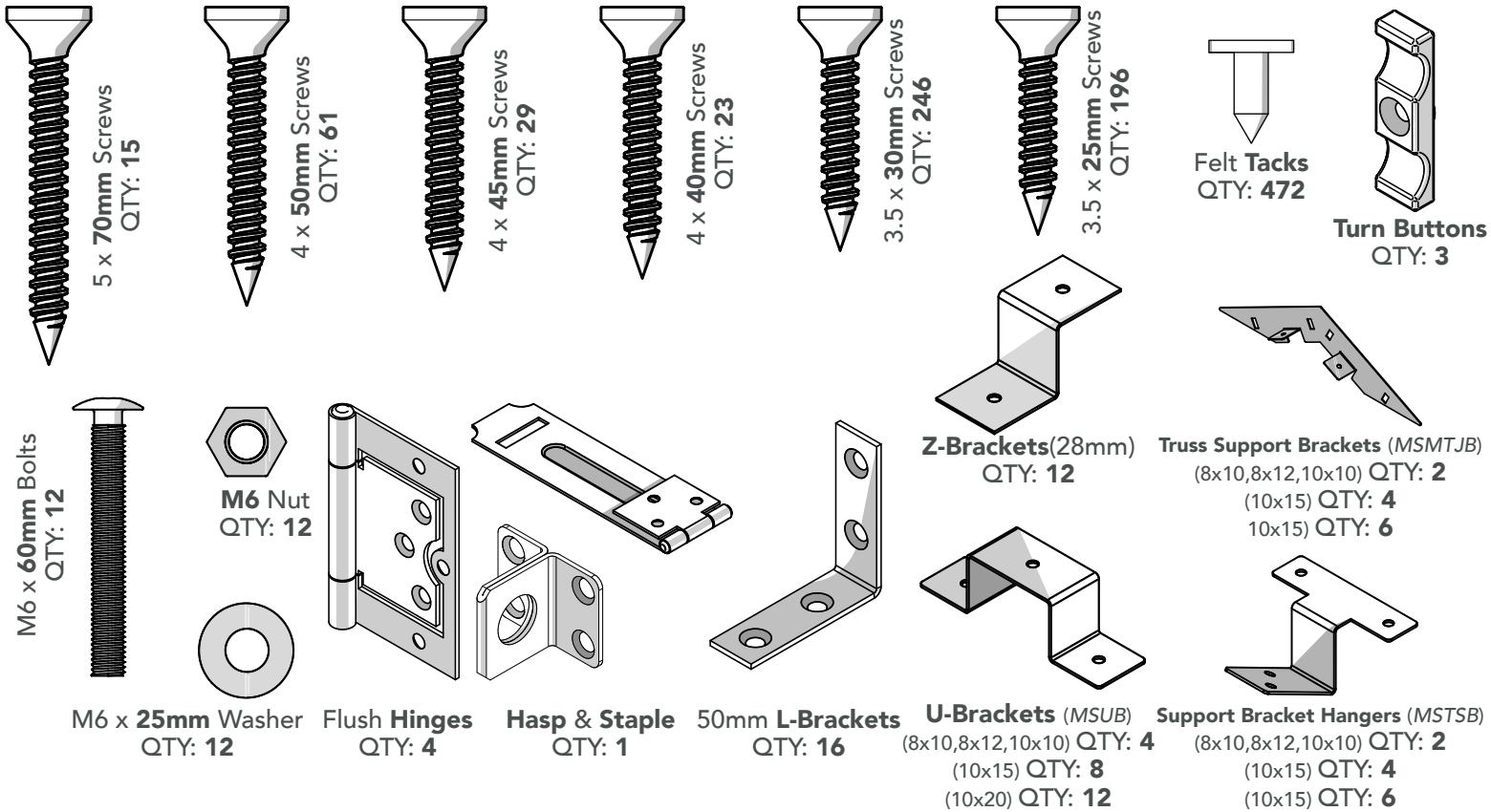

## BEFORE YOU START

Please read through these instructions to familiarise yourself with your shed. We recommend that you **check all the components** using the lists found on the front and back pages before you start to build.

All of our sheds are constructed in the same way. They simply come with different components depending on the type of shed you have. Don't worry if your fixing pack contains some spare items at the end of the build (you haven't missed a bit!) we have sent you a generic fixing pack to suit the shed range.

## BASE PREPARATION

It's vital that you build your new shed on a **solid, level base**. Timber or Plastic Shed Bases are ideal, as is solid concrete or concrete slabs.

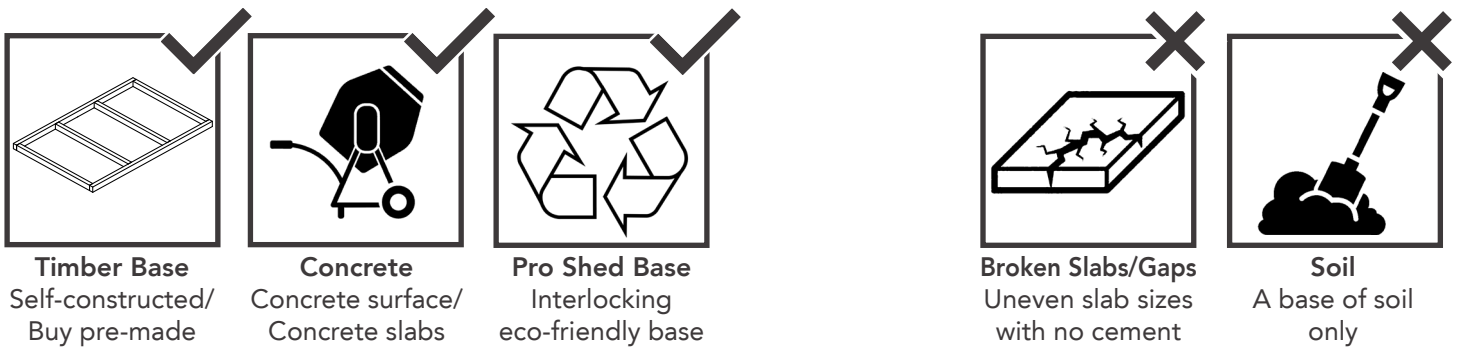

If you have an existing base and think it's suitable for your new shed to be sited on, it is important you check that it is level and doesn't deviate by any more than 15mm from edge to edge. If this isn't the case the building will twist, causing gaps to appear in the sections and the roof, doors and windows to misalign.

## TOOLS NEEDED

We recommend using the following tools (not supplied):



Assembly is relatively straightforward if you follow these step by step instructions. We recommend getting everything aligned properly before screwing together and that **screw holes should be pre-drilled** to avoid splitting the timber.



**IMPORTANT**  
Assembly requires 2+ adults.



**REMINDER**  
Always pre-drill before screwing.

PLEASE KEEP PLASTIC BAGS AND SMALL PARTS AWAY FROM CHILDREN

To help you get the most out of our products it's useful to know a little more about the properties of timber, what's normal and how your shed may behave as the seasons change. Wood is an extremely durable material for construction but as a natural product when used outdoors it is susceptible to changes in the environment.

## THINGS THAT YOU MIGHT SEE IN YOUR PRODUCT



### MOVEMENT, TWISTING & WARPING

Wood contains a natural level of moisture so decreasing humidity levels in the surrounding air may cause panels to change their shape as the porous fibres shrink. This can be exaggerated during prolonged periods of dry weather. Movement and gaps in timber products are normal, in most cases the wood will revert to its original form once the high temperatures subside and there is more moisture content in the air. Similarly, in the winter months, the opposite may occur with wood swelling.



### EXPANSION, CONTRACTION, SPLITS & CRACKS

All timber will expand and contract according to its environment. As a result of this expansion and contraction, it is very common to see splits and cracks developing in the wood. Splits are common during the spring and summer months as the wood begins to dry out. The outer surface dries first and contracts, contracting over a still expanded core of the wood. The result of this is that splits and cracks appear along the grain of wood. These splits are not a fault and do not affect the structural integrity of a product.



### MOULD & BLUE STAIN

Mould is a surface-dwelling fungus that feeds on the nutrients and debris contained in the surface cells of timber. The most common problems associated with mould are discoloured timber and an increase in permeability of the timber. Blue stain is part of the same family but penetrates deeper into the surface layers of the timber. It stains the timber a dark blue, whereas mould is usually black. These do not cause the timber to rot. Keep the building well ventilated to avoid mould.

Treat your building annually, we advise the application of a high quality preservative that contains a mildewcide.

### ADVICE ON FELT HANDLING & USAGE

Roofing felt is flexible at temperatures above 5°C. In cold temperatures extra care must be taken when handling and installing to prevent cracking and damage to the felt. The felt should not be rolled, folded or used in temperatures lower than 5° C. In cold temperatures the felt should be stored above 10°C (indoors) for 24 hours prior to use. Felt must be lifted, not dragged and should be stored on its end on a dry surface.

### THE ROOF OF THIS BUILDING IS NOT A LOAD BEARING STRUCTURE

## 8 TOP TIPS TO ENSURE YOUR SHED IS FULLY WATERPROOF

- 1 MAKE SURE YOU POSITION YOUR SHED IN THE BEST LOCATION IN YOUR GARDEN**  
Avoid areas where water pools and is constantly wet. Position away from trees and cut back any overhanging foliage which can cause moisture to be trapped against shed walls and debris to collect on the roof.
- 2 RAISE YOUR SHED OFF THE GROUND**  
Ideally any concrete base should be the same footprint as the shed to allow surface water to run off without pooling, a timber shed base can also be used. Raise 50mm above ground level.
- 3 SEAL THE BASE**  
We recommend a treatment containing wax or oil, paint the bearers that come into contact with the ground to prevent moisture coming up.
- 4 USE AN END-GRAIN PROTECTOR**  
To protect the corners and panel joints, an end grain treatment can be applied.
- 5 SEAL THE PANELS & WINDOWS**  
Use a flexible silicone sealant around windows to prevent water ingress. This can also be used where 2 sections of the shed joint together. Apply internally.
- 6 CONSIDER ADDING GUTTERS**  
Adding guttering around the fascia of the shed will redirect rain water away from the shed's foundation.
- 7 KEEP VENTILATED**  
Good airflow around the perimeter of the shed and regular ventilation inside the shed will help prevent mould and mildew.
- 8 CONSIDER A WEATHERPROOFING STAIN OR CLEAR TREATMENT**  
We recommend you paint your garden shed with a weatherproofing treatment at least once a year. This will help maintain the wood, stabilise timber movement and help prolong the life of your shed.



### TREATED TIMBER CONTAINING A BIOCIDAL PRODUCT CONTROL OF WOOD DESTROYING ORGANISMS

**Active Ingredients** - Propiconazole, Tebuconazole, IPBC, Permethrine, Benzalkonium chloride. (Dip Treated Sheds)  
Basic Copper Carbonate, DDA Carbonate, DDA Chloride (Pressure Treated Sheds)

Wear gloves when handling. Avoid inhalation of sawdust. Do not use in contact with drinking water or food. Do not use for animal bedding or in fish ponds. Dispose of treated wood responsibly.

# IDENTIFY YOUR SHED

From the **section layout** below, identify your shed based on the **width** and **depth** dimensions of your shed – eg 8x10. You'll need this to identify the side panel positions.

## KEY

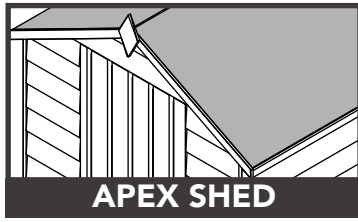

**A** 1ft Panel (295 x 1603mm)

**D** 3ft Panel (885 x 1603mm)  
(With & without windows)

**B** 1.5ft Panel (442 x 1603mm)

**E** 4ft Panel (1180 x 1603mm)  
(With & without windows)

**C** 2ft Panel (590 x 1603mm)

**PLEASE NOTE**  
The sheds are made up of multiple sections where same size panels are interchangeable.

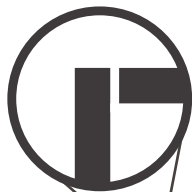

Indicates the panel orientation during construction. This will apply to all of the corners for your chosen shed.

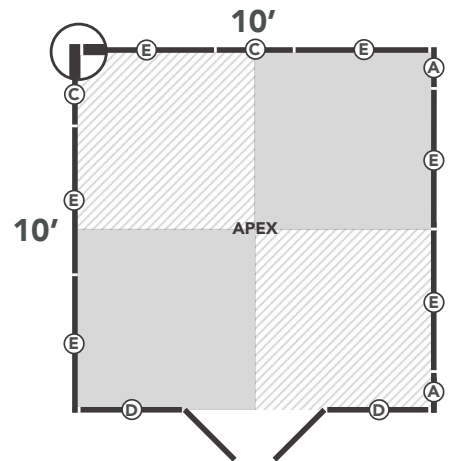
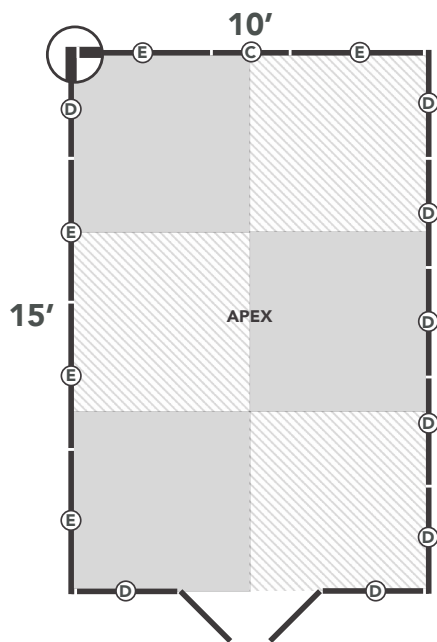
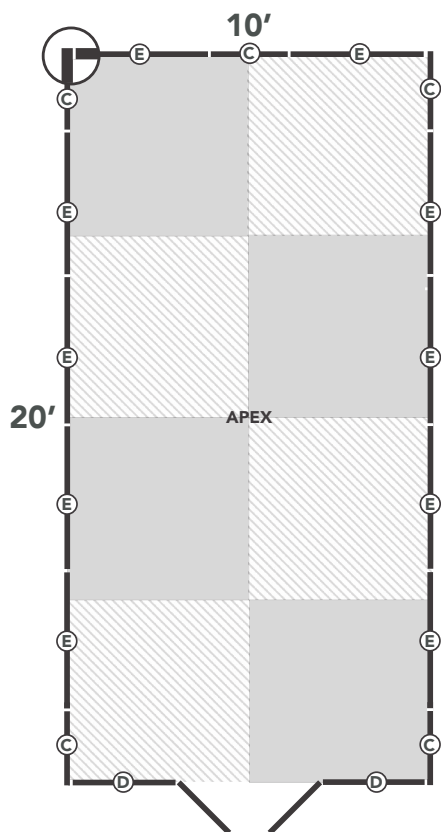
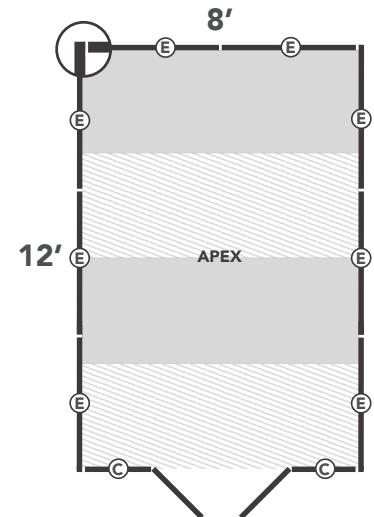
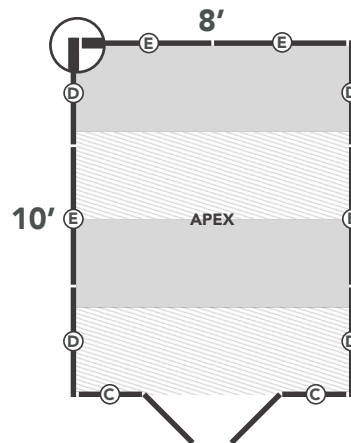
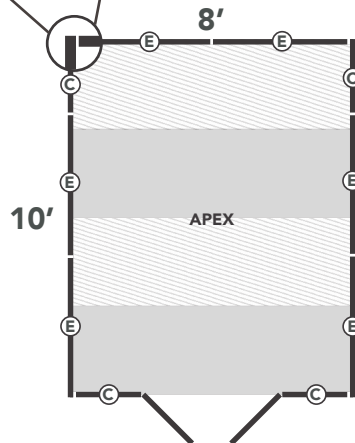

# 1 CONSTRUCTION

## 1a FLOORS & SIDES



Position the floors in your desired location. Follow the step provided based on your type of shed to piece the floors together as shown below. Use your section layout on page 4, which shows the amount of floors for your chosen shed.

Layout the panels around your shed base.

We recommend to start in a back corner then work from the back panels to the front panels for assembly.

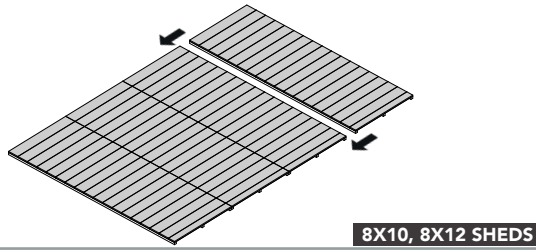

8X10, 8X12 SHEDS

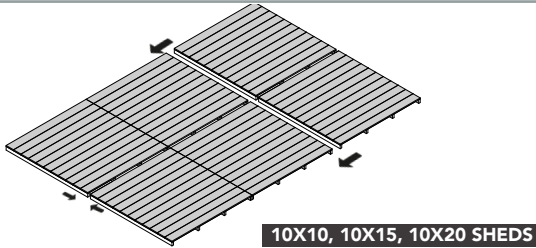

10X10, 10X15, 10X20 SHEDS

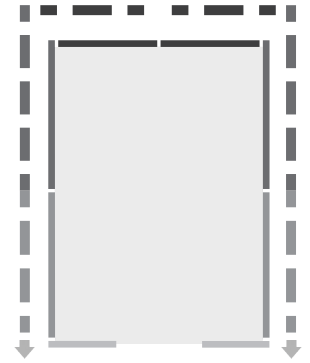
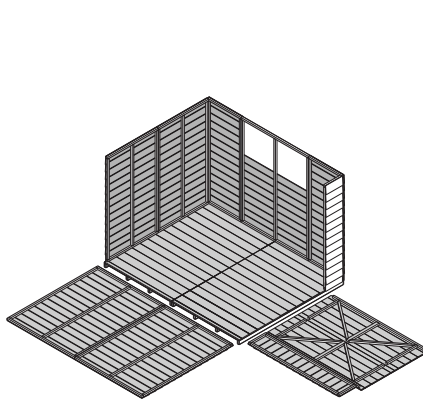

## 1b

Start at a back corner. See the section layout on page 4 to confirm position. Secure the corner as shown below.

Repeat the process for remaining panels and secure panels together. Make sure that the bottom frame of the wall panel rests on the outer edge of the floor.

Secure the panels into place by screwing into the floor. Screw the door batten down.

EG. INSIDE CORNER

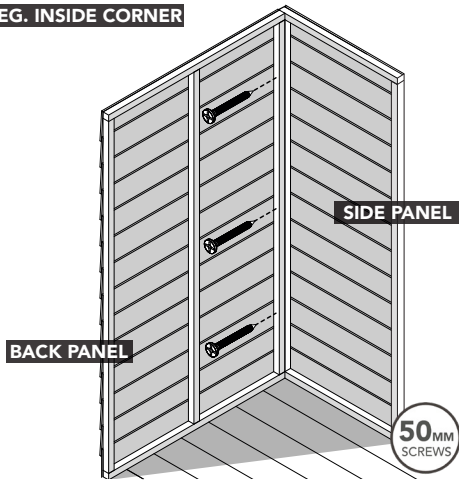

EG. SIDES

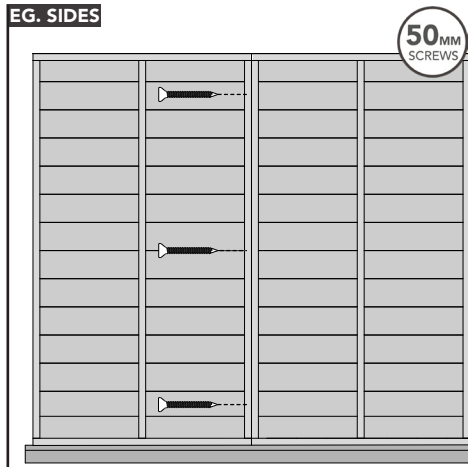

EG. INTO FLOOR

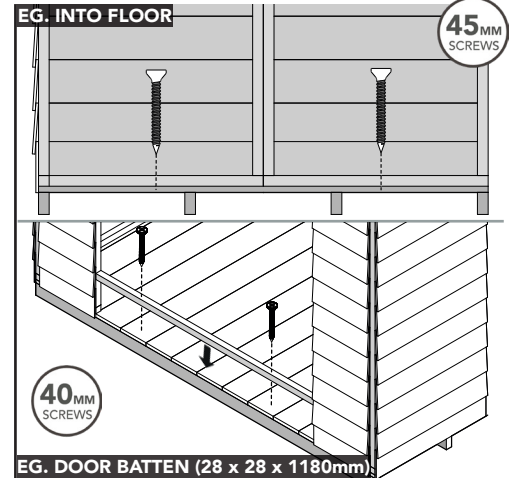

## 1c

Attach the Back Apex Section by screwing to the wall panels. Leave the Front Apex Section off at this step. This step applies to the 8x10 and 8x12.

For the 10x10, 10x15 and 10x20, assemble the front and back Apex Sections shown below.

Once assembled, attach the Back Apex Section by screwing to the wall panels. Leave the Front Apex Section off at this step. This step applies to the 10x10, 10x15 and 10x20.

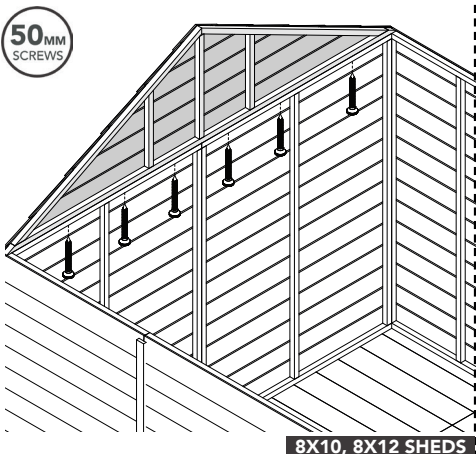

8X10, 8X12 SHEDS

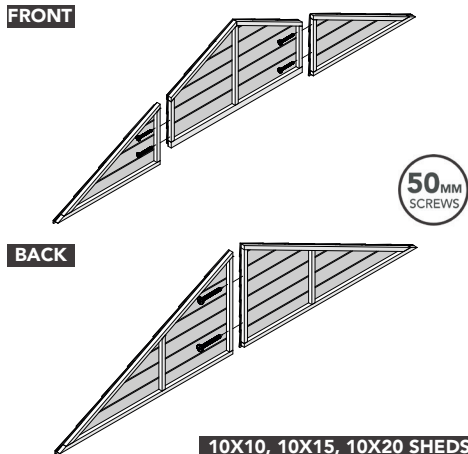

10X10, 10X15, 10X20 SHEDS

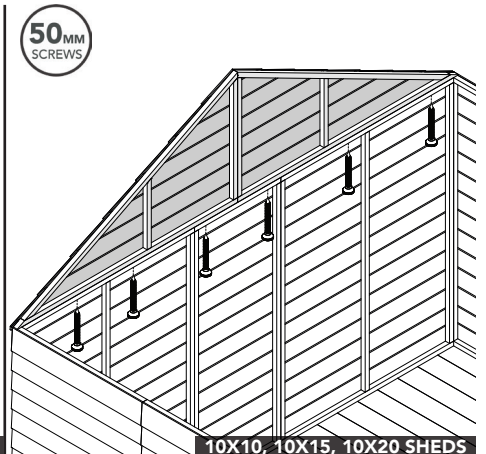

10X10, 10X15, 10X20 SHEDS

# 2 WINDOWS

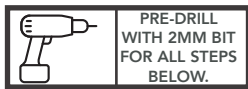

Fix interior sills at the base of windows with L-brackets and screws at a 1002mm distance from the floor. Repeat this for multiple windows, as shown below.

Secure windows by screwing through the window cover strips and window into the panel frame. Screw into the bottom of the window and into the interior sill to keep secure. Make sure the window is centralised for all window frames as shown below.

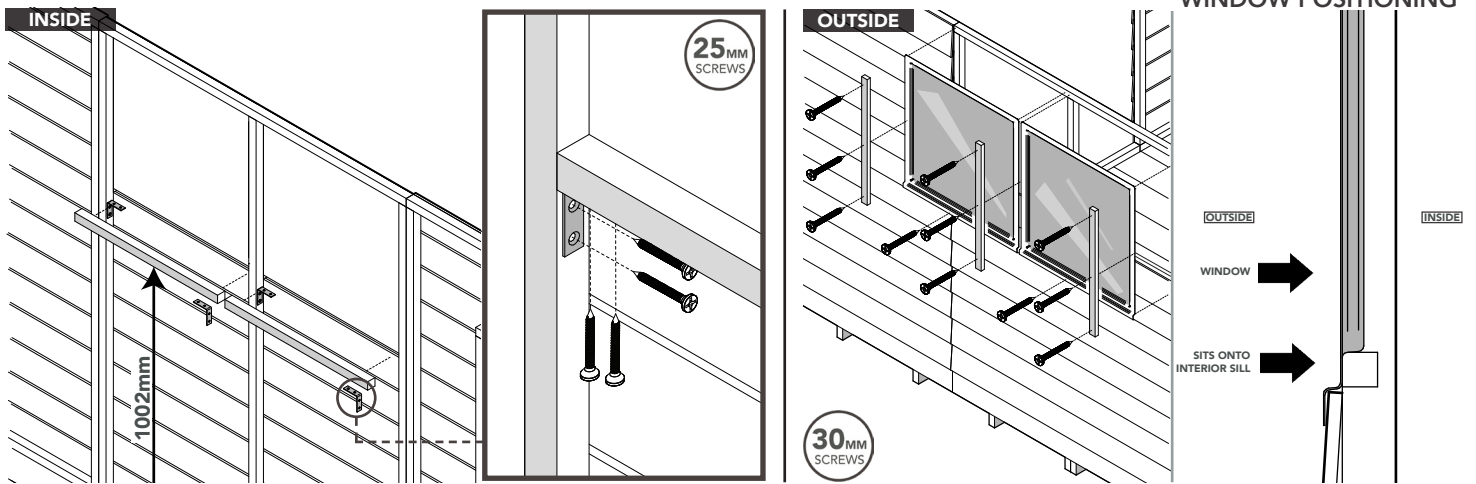

# 3 COVER AND DOOR STRIPS



Attach the cover strips onto the corners. Ensuring they are flush to the bottom edge of the panels as shown below.

Attach the cover strips onto the adjoining panels. Ensuring it is flush to the bottom edge of the panels as shown below.

Secure the door weather strips. Ensure it's flush to the floor and against the inside face of the wall panel frame as shown below.

Before attaching the doors, screw the slamming strip onto the one door. Ensure you screw through the slamming strip into the door framework as shown below.

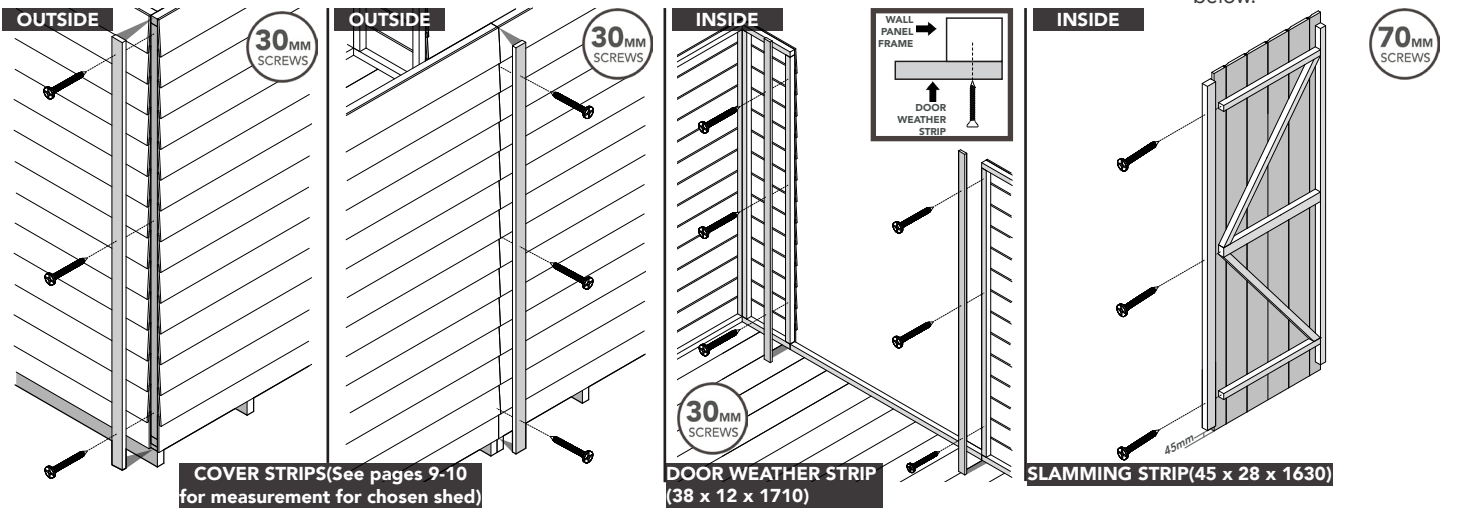

# 4 ROOF



Assemble the truss and screw the U-brackets onto each beam. Ensure the truss support brackets are added first and flush to the edge of the central beams to establish the correct angle. Screw the battens to the beams, underneath the truss support brackets.

For the 8x10, 8x12 and 10x10 sheds, secure the support bracket hanger with screws into the center of your shed. There needs to be one at each side.

For the 10x15 and 10x20 sheds, secure the support bracket hangers with screws onto the panels of your shed with the measurements shown below. There needs to be one at each side.

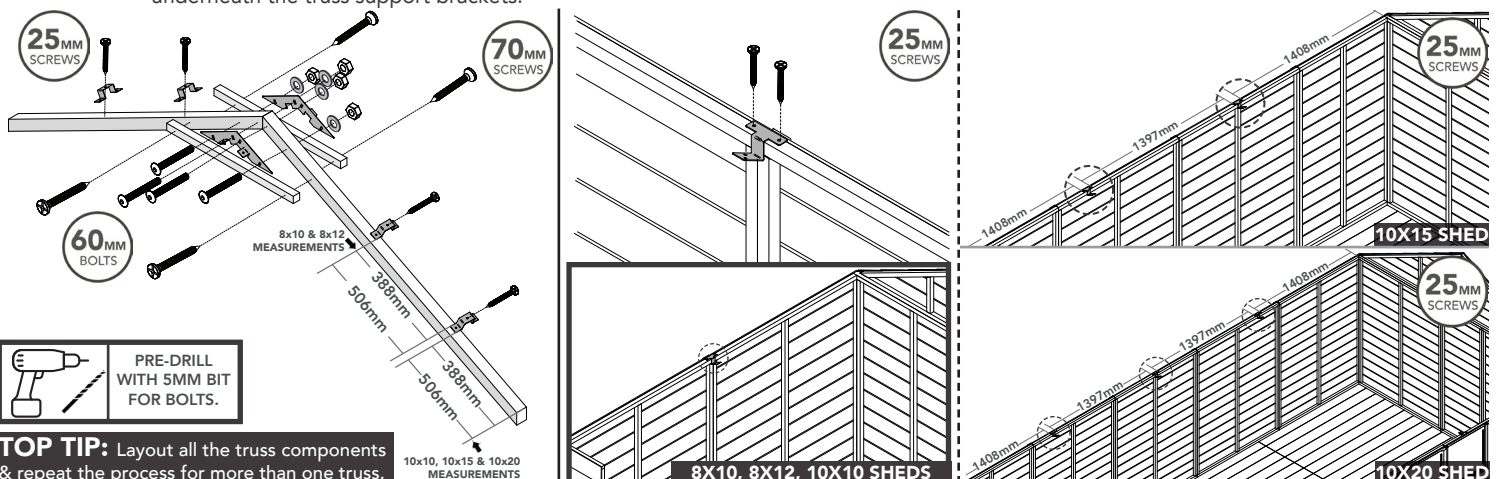

# 4b

Before placing the OSB roof sheets onto the roof, screw the roof support strips along the edge of the OSB roof sheets. Ensuring they are flush to the edges. Add one strip onto each sheet as shown below. The strip will be the same length as one side of the sheet.

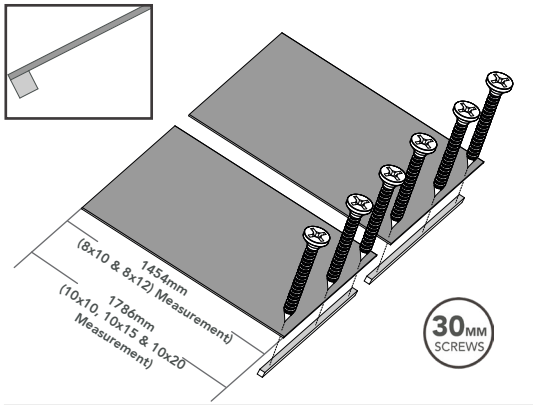

**PLEASE NOTE**  
For the 10x15 & 10x20 sheds, the front and back OSB roof sheets are bigger than the ones in the centre.

For 10x10, 10x15 and 10x20 sheds, screw the back Apex Section cover strip onto the join line. If you are not constructing these shed sizes, skip this step.

**Screw the truss to the support bracket hangers.**  
For the 10x15 and 10x20 sheds, screw only one truss to the back support bracket hangers first.

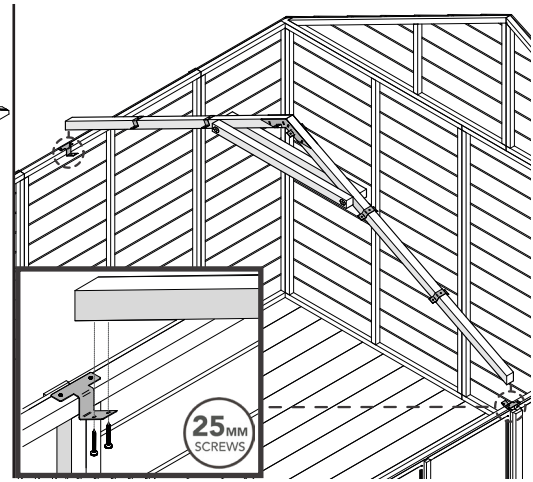
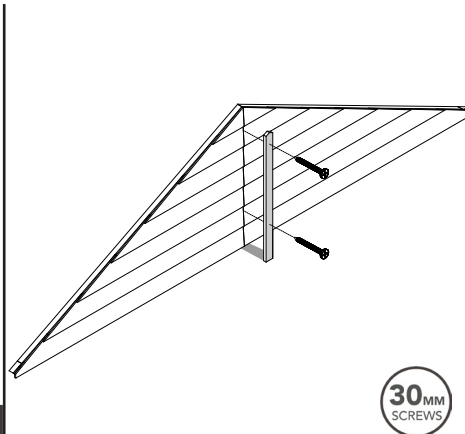

# 4c

**PREPARATION:** Attach the Z-brackets onto the face of one end of the 12 beams as shown below. The beam should be flush to the Z-bracket.

**ATTACHMENT:** Secure the other end of the beams to the U-brackets on the truss by screwing from the underside of the beam.

Screw the Z-brackets that are already attached to the beams onto the back apex section frame. This will apply to all of sheds.

Starting at the back, screw the OSB roof sheets into position with the sheet edge onto the centre of the truss central beam, as shown below into the shed frame and truss. The 10x15 and 10x20 sheds will have slight differences in sizes, therefore use the measurements shown below.

**PLEASE NOTE**  
For the 10x15 & 10x20 sheds, the front and back OSB roof sheets are bigger than the ones in the centre.

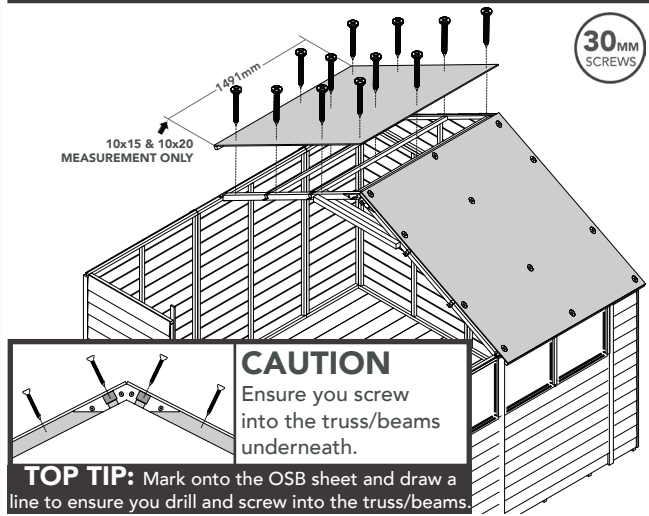
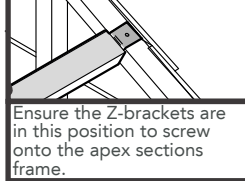
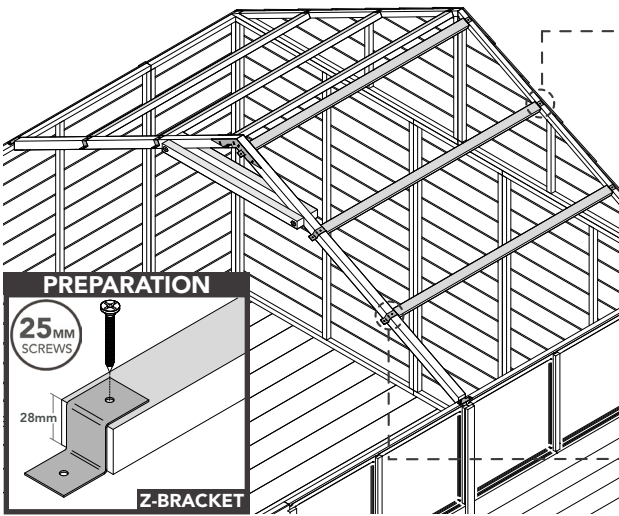

# 4d

The 10x15 and 10x20 sheds will repeat the process for the rest of the beams, truss and OSB roof sheets, working down to the front. Attach the beams without Z-brackets onto the U-brackets provided between each truss by screwing from the underside of the beam.

Before applying the last beams and OSB roof sheets, attach the front apex section (assembled). Then screw the cover strips into the apex section panel join lines shown below.

Apply the final beams by screwing the Z-brackets that are already attached to the beams onto the front apex section frame.

## 10X15 & 10X20 SHEDS

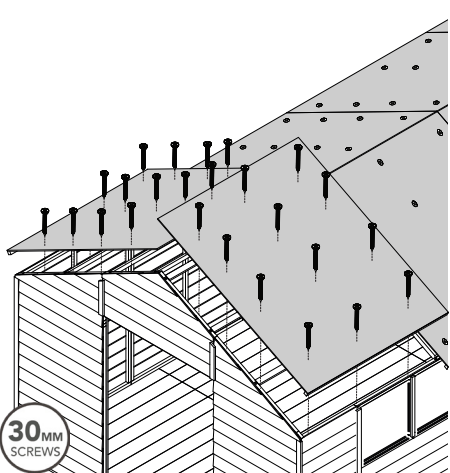
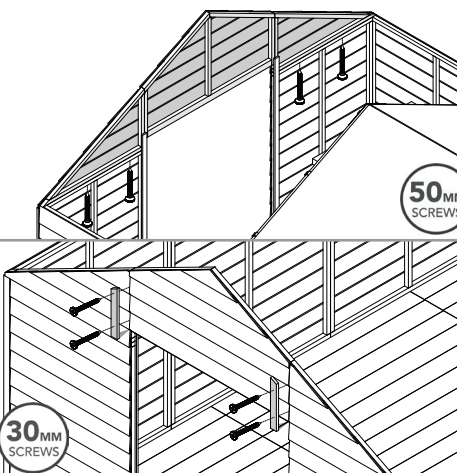
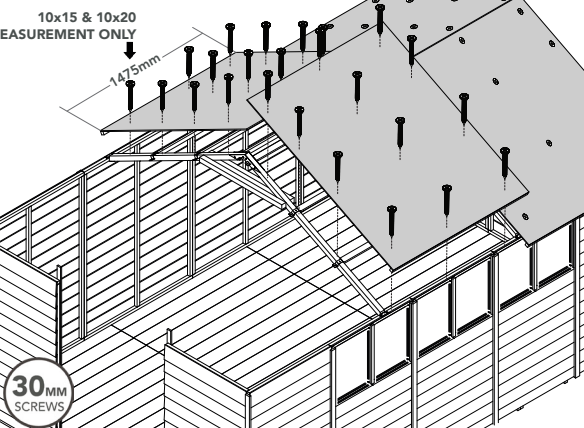

# 4e

Measure out 4 equal lengths and overlap it on the top, around the edges and **fold the corners**; tack to **keep secure**. Ensure 50mm at the bottom and work from the bottom to the top.

**TOP TIP:** Use measuring tape to measure out 4 equal lengths & cut with a sharp knife. Hammer the tacks into the felt. Add the tacks at 150mm intervals.

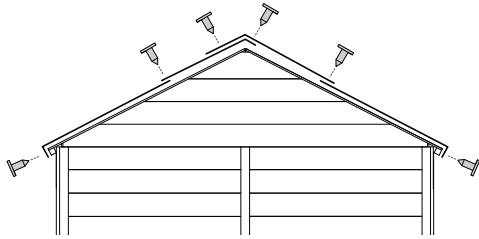
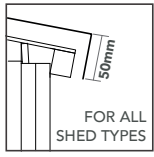

Secure the fascias and the finial with screws as shown below based on your chosen shed.

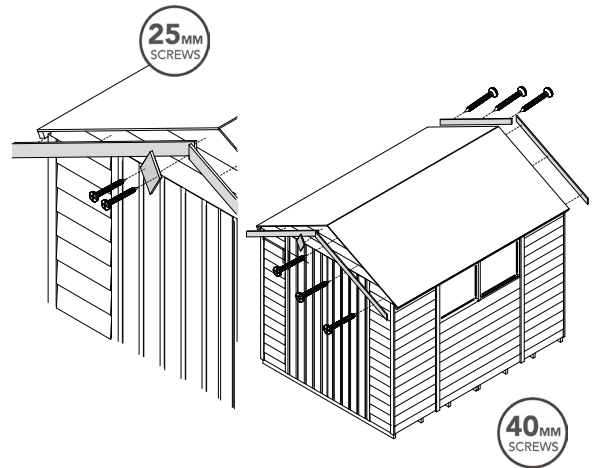

# 5a DOOR FIXINGS



Attach 2 hinges onto the door frame with the measurements provided. Please take note of the hinge position shown below. Repeat this on the other door.

Place the door into the opening, ensuring it's level. Make sure the hinges are up against the door weather strip face. Repeat this with the other door.

Fix the Hasp and Staple as shown. Ensure the screws go into the framework behind.

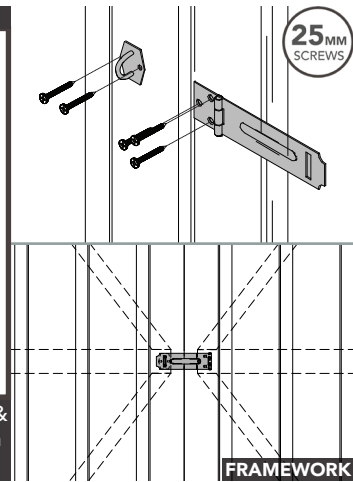
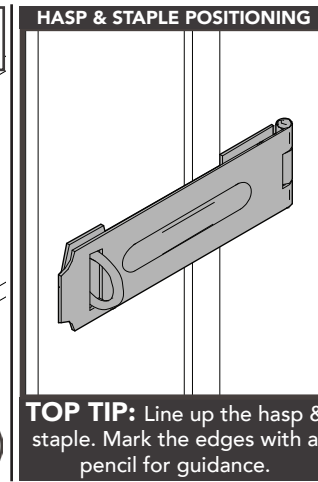
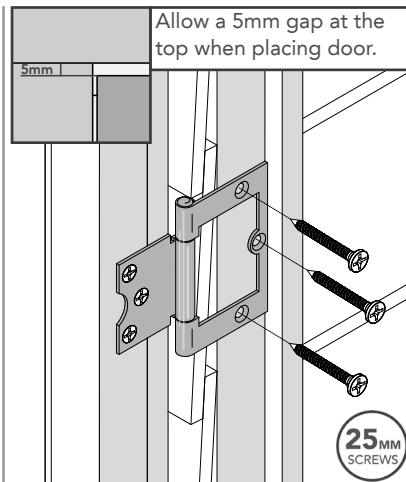
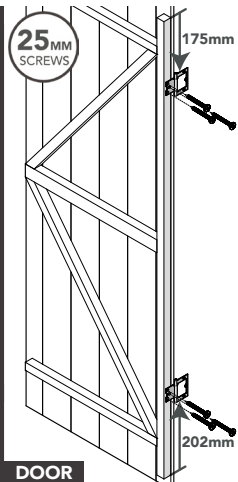
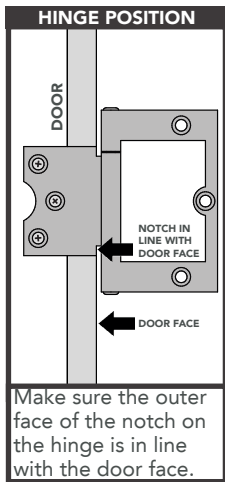

# 5b

Fix the turn buttons as shown below. Screw one turn button at the top and at the bottom of the slamming strip. Screw into the slamming strip, ensuring it overlaps the frame.

Fix the turn button as shown below. Screw one turn button into the Apex Section, ensuring it overlaps the door. Make sure you screw the turn button above the door that does not have the slamming strip attached to it.

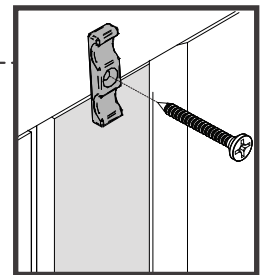
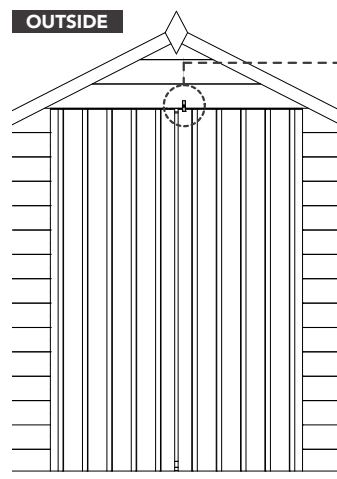
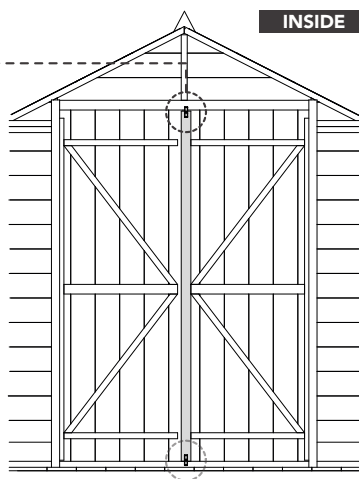
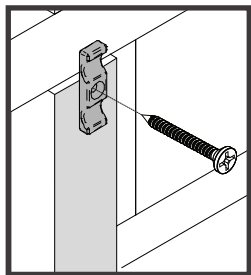

# DIP TREATED APEX SHEDS

SELECT YOUR CHOSEN SHED & CHECK YOU HAVE ALL YOUR PARTS.

Overlap Apex 8' x 10' - 4 Windows (ODA810DDM)		
Part Code	Description	No.
ODM590PP	Section C - 2ft Panel (590 x 1603mm)	4
ODM1180WP	Section E - 4ft Window Panel (1180x1603mm)	2
ODM1180PP	Section E - 4ft Panel (1180x1603mm)	4
ODAMPEA8	Apex Section - Back	1
ODAMDDDEA8	Apex Section - Door	1
MWSBFL258	Floor	4
MSDDR	Door	2
28120550PDT	Window Cover Strip (28x12x550mm)	6
28280548DT	Interior Sill (28x28x548mm)	4
28281180DT	Door Batten (28x28x1180mm)	1
28281491	Roof Support Strip (28x28x1491mm)	4
38121710PDT	Weather Strip (38x12x1710mm)	2
40121583PDT	Cover Strip (40x12x1583mm)	9
45281421P	Beam - Truss (45x28x1421mm)	12
45281630DT	Slamming Strip (45x28x1630mm)	1
45450700P	Truss Support Batten (45x45x700mm)	2
45451346PAI63	Central Beam - Truss (45x45x1346mm)	2
59121493PAI63DT	Fascia (59x12x1493mm)	4
RPET590	Window	4
OSB149114548	OSB Sheet - Roof	4
FIN20010512DT	Finial	1
85008	Felt	4

Overlap Apex 8' x 10' - No Windows (ODA810DDNWM)		
Part Code	Description	No.
ODM885PP	Section D - 3ft Panel (885 x 1603mm)	4
ODM590PP	Section C - 2ft Panel (590 x 1603mm)	2
ODM1180PP	Section E - 4ft Panel (1180x1603mm)	4
ODAMPEA8	Apex Section - Back	1
ODAMDDDEA8	Apex Section - Door	1
MWSBFL258	Floor	4
MSDDR	Door	2
28281180DT	Door Batten (28x28x1180mm)	1
28281491	Roof Support Strip (28x28x1491mm)	4
38121710PDT	Weather Strip (38x12x1710mm)	2
44161583DT	Cover Strip (44x16x1583mm)	9
45281421P	Beam - Truss (45x28x1421mm)	12
45281630DT	Slamming Strip (45x28x1630mm)	1
45450700P	Truss Support Batten (45x45x700mm)	2
45451346PAI63	Central Beam - Truss (45x45x1346mm)	2
59121493PAI63DT	Fascia (59x12x1493mm)	4
OSB149114548	OSB Sheet - Roof	4
FIN20010512DT	Finial	1
85052	Felt	4

Overlap Apex 8' x 12' - 6 Windows (ODA812DDM)		
Part Code	Description	No.
ODM590PP	Section C - 2ft Panel (590 x 1603mm)	2
ODM1180WP	Section E - 4ft Window Panel (1180x1603mm)	3
ODM1180PP	Section E - 4ft Panel (1180x1603mm)	5
ODAMPEA8	Apex Section - Back	1
ODAMDDDEA8	Apex Section - Door	1
MWSBFL38	Floor	4
MSDDR	Door	2
28160550DT	Window Cover Strip (28x16x550mm)	9
28280548DT	Interior Sill (28x28x548mm)	6
28281180DT	Door Batten (28x28x1180mm)	1
28281786	Roof Support Strip (28x28x1786mm)	4
38121710PDT	Weather Strip (38x12x1710mm)	2
44161583DT	Cover Strip (44x16x1583mm)	9
45281630DT	Slamming Strip (45x28x1630mm)	1
45281716P	Beam - Truss (45x28x1716mm)	12
45450700P	Truss Support Batten (45x45x700mm)	2
45451346PAI63	Central Beam - Truss (45x45x1346mm)	2
59121493PAI63DT	Fascia (59x12x1493mm)	4
RPET590	Window	6
OSB178614548	OSB Sheet - Roof	4
FIN20010512DT	Finial	1
85052	Felt	4

Overlap Apex 8' x 12' - No Windows (ODA812DDNWM)		
Part Code	Description	No.
ODM590PP	Section C - 2ft Panel (590 x 1603mm)	2
ODM1180PP	Section E - 4ft Panel (1180x1603mm)	8
ODAMPEA8	Apex Section - Back	1
ODAMDDDEA8	Apex Section - Door	1
MWSBFL38	Floor	4
MSDDR	Door	2
28281180DT	Door Batten (28x28x1180mm)	1
28281786	Roof Support Strip (28x28x1786mm)	4
38121710PDT	Weather Strip (38x12x1710mm)	2
44161583DT	Cover Strip (44x16x1583mm)	9
45281630DT	Slamming Strip (45x28x1630mm)	1
45281716P	Beam - Truss (45x28x1716mm)	12
45450700P	Truss Support Batten (45x45x700mm)	2
45451346PAI63DT	Central Beam - Truss (45x45x1346mm)	2
59121493PAI63DT	Fascia (59x12x1493mm)	4
OSB178614548	OSB Sheet - Roof	4
FIN20010512DT	Finial	1
85052	Felt	4

Shiplap Apex 8' x 10' - 4 Windows (SDA810DDM)		
Part Code	Description	No.
SDM590PP	Section C - 2ft Panel (590 x 1603mm)	4
SDM1180WP	Section E - 4ft Window Panel (1180x1603mm)	2
SDM1180PP	Section E - 4ft Panel (1180x1603mm)	4
SDAMPEA8	Apex Section - Back	1
SDAMDDDEA8	Apex Section - Door	1
MWSBFL258	Floor	4
MSDDR	Door	2
28120550PDT	Window Cover Strip (28x12x550mm)	6
28280548DT	Interior Sill (28x28x548mm)	4
28281180DT	Door Batten (28x28x1180mm)	1
28281491	Roof Support Strip (28x28x1491mm)	4
38121710PDT	Weather Strip (38x12x1710mm)	2
40121583PDT	Cover Strip (40x12x1583mm)	9
45281421P	Beam - Truss (45x28x1421mm)	12
45281630DT	Slamming Strip (45x28x1630mm)	1
45450700P	Truss Support Batten (45x45x700mm)	2
45451346PAI63	Central Beam - Truss (45x45x1346mm)	2
59121493PAI63DT	Fascia (59x12x1493mm)	4
RPET590	Window	4
OSB149114548	OSB Sheet - Roof	4
FIN20010512DT	Finial	1
85008	Felt	4

Shiplap Apex 8' x 12' - 4 Windows (SDA812DDM)		
Part Code	Description	No.
SDM590PP	Section C - 2ft Panel (590 x 1603mm)	2
SDM1180WP	Section E - 4ft Window Panel (1180x1603mm)	3
SDM1180PP	Section E - 4ft Panel (1180x1603mm)	5
SDAMPEA8	Apex Section - Back	1
SDAMDDDEA8	Apex Section - Door	1
MWSBFL38	Floor	4
MSDDR	Door	2
28120550PDT	Window Cover Strip (28x12x550mm)	9
28280548DT	Interior Sill (28x28x548mm)	6
28281180DT	Door Batten (28x28x1180mm)	1
28281786	Roof Support Strip (28x28x1786mm)	4
38121710PDT	Weather Strip (38x12x1710mm)	2
40121583PDT	Cover Strip (40x12x1583mm)	9
45281630DT	Slamming Strip (45x28x1630mm)	1
45281716P	Beam - Truss (45x28x1716mm)	12
45450700P	Truss Support Batten (45x45x700mm)	2
45451346PAI63	Central Beam - Truss (45x45x1346mm)	2
59121493PAI63DT	Fascia (59x12x1493mm)	4
RPET590	Window	6
OSB178614548	OSB Sheet - Roof	4
FIN20010512DT	Finial	1
85008	Felt	4

(The parts do not have codes on them. They are listed above should you need to order one.)

# PRESSURE TREATED APEX SHEDS

SELECT YOUR CHOSEN SHED & CHECK YOU HAVE ALL YOUR PARTS.

Overlap Apex 8' x 10' - 4 Windows (OPA810DDM)		
Part Code	Description	No.
OPM590PP	Section C - 2ft Panel (590 x 1603mm)	4
OPM1180WP	Section E - 4ft Window Panel (1180x1603mm)	2
OPM1180PP	Section E - 4ft Panel (1180x1603mm)	4
OPAMPEA8	Apex Section - Back	1
OPAMDDDEA8	Apex Section - Door	1
MWSBFL258	Floor	4
MSPDR	Door	2
28160550PT	Window Cover Strip (28x16x550mm)	6
28280548PT	Interior Sill (28x28x548mm)	4
28281180PT	Door Batten (28x28x1180mm)	1
28281491	Roof Support Strip (28x28x1491mm)	4
38121710PPT	Weather Strip (38x12x1710mm)	2
44161583PT	Cover Strip (44x16x1583mm)	9
45281421P	Beam - Truss (45x28x1421mm)	12
45281630PT	Slamming Strip (45x28x1630mm)	1
45450700P	Truss Support Batten (45x45x700mm)	2
45451346PAI63	Central Beam - Truss (45x45x1346mm)	2
59121493PAI63PT	Fascia (59x12x1493mm)	4
OSB149114548	OSB Sheet - Roof	4
FIN20010512PT	Finial	1
RPET590	Window	4
OSB149114548	OSB Sheet - Roof	4
FIN20010512PT	Finial	1
85052	Felt	4

Overlap Apex 8' x 10' - No Windows (OPA810DDNWM)		
Part Code	Description	No.
OPM885PP	Section D - 3ft Panel (885 x 1603mm)	4
OPM590PP	Section C - 2ft Panel (590 x 1603mm)	2
OPM1180PP	Section E - 4ft Panel (1180x1603mm)	4
OPAMPEA8	Apex Section - Back	1
OPAMDDDEA8	Apex Section - Door	1
MWSBFL258	Floor	4
MSPDR	Door	2
28281180PT	Door Batten (28x28x1180mm)	1
28281491	Roof Support Strip (28x28x1491mm)	4
38121710PPT	Weather Strip (38x12x1710mm)	2
44161583PT	Cover Strip (44x16x1583mm)	9
45281421P	Beam - Truss (45x28x1421mm)	12
45281630PT	Slamming Strip (45x28x1630mm)	1
45450700P	Truss Support Batten (45x45x700mm)	2
45451346PAI63	Central Beam - Truss (45x45x1346mm)	2
59121493PAI63PT	Fascia (59x12x1493mm)	4
OSB149114548	OSB Sheet - Roof	4
FIN20010512PT	Finial	1
85052	Felt	4

Overlap Apex 10' x 10' - 4 Windows (OPA1010DDM)		
Part Code	Description	No.
OPM590PP	Section C - 2ft Panel (590 x 1603mm)	2
OPM295PP	Section A - 1ft Panel (295x 1603mm)	2
OPM1180WP	Section E - 4ft Window Panel (1180x1603mm)	2
OPM1180PP	Section E - 4ft Panel (1180x1603mm)	4
OPAMPEASRH	Apex Section - Right Back	1
OPAMPEASLH	Apex Section - Left Back	1
OPAMDDDEASRH	Apex Section - Right Door	1
OPAMDDDEASMD	Apex Section - Mid Door	1
OPAMDDDEASLH	Apex Section - Left Door	1
MWSBFL55	Floor	4
MSPDR	Door	2
28160550PT	Window Cover Strip (28x16x550mm)	6
28280548PT	Interior Sill (28x28x548mm)	4
28281180PT	Door Batten (28x28x1180mm)	1
28281491	Roof Support Strip (28x28x1491mm)	4
38121710PPT	Weather Strip (38x12x1710mm)	2
44160325AI63PT	Apex Section - Front Cover Strip (44x16x325mm)	2
44160730AI63PT	Apex Section - Back Cover Strip (44x16x730mm)	1
44161583PT	Cover Strip (44x16x1583mm)	11
45281421P	Beam - Truss (45x28x1421mm)	12
45281630PT	Slamming Strip (45x28x1630mm)	1
45450895P	Truss Support Batten (45x45x895mm)	2
45451677PAI63	Central Beam - Truss (45x45x1677mm)	2
59121825PAI63PT	Fascia (59x12x1825mm)	4
RPET590	Window	4
OSB178614918	OSB Sheet - Roof	4
FIN20010512PT	Finial	1
85052	Felt	5

Overlap Apex 10' x 15' - 6 Windows (OPA1015DDM)		
Part Code	Description	No.
OPM885SWP	Section D - 3ft Window Panel (885 x 1603mm)	3
OPM885PP	Section D - 3ft Panel (885 x 1603mm)	5
OPM590PP	Section C - 2ft Panel (590 x 1603mm)	1
OPM1180PP	Section E - 4ft Panel (1180x1603mm)	5
OPAMPEASRH	Apex Section - Right Back	1
OPAMPEASLH	Apex Section - Left Back	1
OPAMDDDEASRH	Apex Section - Right Door	1
OPAMDDDEASMD	Apex Section - Mid Door	1
OPAMDDDEASLH	Apex Section - Left Door	1
MWSBFL55	Floor	6
MSPDR	Door	2
28160550PT	Window Cover Strip (28x16x550mm)	9
28280400PT	Interior Sill (28x28x400mm)	6
28281180PT	Door Batten (28x28x1180mm)	1
28281475	Roof Support Strip (28x28x1475mm)	2
28281491	Roof Support Strip (28x28x1491mm)	4
38121710PPT	Weather Strip (38x12x1710mm)	2
44160325AI63PT	Apex Section - Front Cover Strip (44x16x325mm)	2
44160730AI63PT	Apex Section - Back Cover Strip (44x16x730mm)	1
44161583PT	Cover Strip (44x16x1583mm)	13
45281421P	Beam - Truss (45x28x1421mm)	12
45281426P	Beam - Truss (45x28x1426mm)	6
45281630PT	Slamming Strip (45x28x1630mm)	1
45450895P	Truss Support Batten (45x45x895mm)	4
45451677PAI63	Central Beam - Truss (45x45x1677mm)	4
59121825PAI63PT	Fascia (59x12x1825mm)	4
RPET885	Window	6
OSB178614758	OSB Sheet - Roof	2
OSB178614918	OSB Sheet - Roof	4
FIN20010512PT	Finial	1
FELT78BL	Felt	5

Overlap Apex 10' x 20' - 8 Windows (OPA1020DDM)		
Part Code	Description	No.
OPM885PP	Section D - 3ft Panel (885 x 1603mm)	2
OPM590PP	Section C - 2ft Panel (590 x 1603mm)	3
OPM1180WP	Section E - 4ft Window Panel (1180x1603mm)	4
OPM1180PP	Section E - 4ft Panel (1180x1603mm)	7
OPAMPEASRH	Apex Section - Right Back	1
OPAMPEASLH	Apex Section - Left Back	1
OPAMDDDEASRH	Apex Section - Right Door	1
OPAMDDDEASMD	Apex Section - Mid Door	1
OPAMDDDEASLH	Apex Section - Left Door	1
MWSBFL55	Floor	8
MSPDR	Door	2
28160550PT	Window Cover Strip (28x16x550mm)	12
28280548PT	Interior Sill (28x28x548mm)	8
28281180PT	Door Batten (28x28x1180mm)	1
28281475	Roof Support Strip (28x28x1475mm)	4
28281491	Roof Support Strip (28x28x1491mm)	4
38121710PPT	Weather Strip (38x12x1710mm)	2
44160325AI63PT	Apex Section - Front Cover Strip (44x16x325mm)	2
44160730AI63PT	Apex Section - Back Cover Strip (44x16x730mm)	1
44161583PT	Cover Strip (44x16x1583mm)	15
45281421P	Beam - Truss (45x28x1421mm)	12
45281426P	Beam - Truss (45x28x1426mm)	12
45281630PT	Slamming Strip (45x28x1630mm)	1
45450895P	Truss Support Batten (45x45x895mm)	6
45451677PAI63	Central Beam - Truss (45x45x1677mm)	6
59121825PAI63PT	Fascia (59x12x1825mm)	4
RPET590	Window	8
OSB178614918	OSB Sheet - Roof	4
OSB178614758	OSB Sheet - Roof	4
FIN20010512PT	Finial	1
FELT78BL	Felt	5

Overlap Apex 8' x 12' - 6 Windows (OPA812DDM)		
Part Code	Description	No.
OPM590PP	Section C - 2ft Panel (590 x 1603mm)	2
OPM1180WP	Section E - 4ft Window Panel (1180x1603mm)	3
OPM1180PP	Section E - 4ft Panel (1180x1603mm)	5
OPAMPEA8	Apex Section - Back	1
OPAMDDDEA8	Apex Section - Door	1
MWSBFL38	Floor	4
MSPDR	Door	2
28160550PT	Window Cover Strip (28x16x550mm)	9
28280548PT	Interior Sill (28x28x548mm)	6
28281180PT	Door Batten (28x28x1180mm)	1
28281786	Roof Support Strip (28x28x1786mm)	4
38121710PPT	Weather Strip (38x12x1710mm)	2
44161583PT	Cover Strip (44x16x1583mm)	9
45281630PT	Slamming Strip (45x28x1630mm)	1
45281716P	Beam - Truss (45x28x1716mm)	12
45450700P	Truss Support Batten (45x45x700mm)	2
45451346PAI63	Central Beam - Truss (45x45x1346mm)	2
59121493PAI63PT	Fascia (59x12x1493mm)	4
RPET590	Window	6
OSB178614548	OSB Sheet - Roof	4
FIN20010512PT	Finial	1
85052	Felt	4

Overlap Apex 8' x 12' - No Windows (OPA812DDNWM)		
Part Code	Description	No.
OPM590PP	Section C - 2ft Panel (590 x 1603mm)	2
OPM1180PP	Section E - 4ft Panel (1180x1603mm)	8
OPAMPEA8	Apex Section - Back	1
OPAMDDDEA8	Apex Section - Door	1
MWSBFL38	Floor	4
MSPDR	Door	2
28281180PT	Door Batten (28x28x1180mm)	1
28281786	Roof Support Strip (28x28x1786mm)	4
38121710PPT	Weather Strip (38x12x1710mm)	2
44161583PT	Cover Strip (44x16x1583mm)	9
45281630PT	Slamming Strip (45x28x1630mm)	1
45281716P	Beam - Truss (45x28x1716mm)	12
45450700P	Truss Support Batten (45x45x700mm)	2
45451346PAI63	Central Beam - Truss (45x45x1346mm)	2
59121493PAI63PT	Fascia (59x12x1493mm)	4
OSB178614548	OSB Sheet - Roof	4
FIN20010512PT	Finial	1
85052	Felt	4

(The parts do not have codes on them. They are listed above should you need to order one.)