







ASSEMBLY INSTRUCTIONS

-K SHASTA SIDE CHAIR

Thank you for purchasing this quality product. Be sure to check all packing material carefully for small parts, which may have come loose inside the carton during shipment. Identify and count all parts and compare with the Hardware List below.

| | No. | Description | Qty |
|------------------------------|-----|-----------------|-----|
| SHASTA SIDE CHAIR | A | Chair back | 1 |
| | B | Seat with frame | 1 |
| | C | Legs | 2 |

| | No. | Picture | Description | Dimension | Qty |
|-----------------|-----|---|---------------------|-------------|-----|
| HARDWARE | 1 |  | Short machine bolt | M8 x 50 mm | 2 |
| | 2 |  | Medium machine bolt | M8 x 55 mm | 4 |
| | 3 |  | Long machine bolt | M8 x 100 mm | 4 |
| | 4 |  | Lock washer | Ø13xØ8x2 mm | 10 |
| | 5 |  | Flat washer | Ø18xØ8x2 mm | 10 |
| | 6 |  | Allen key | L6 | 1 |

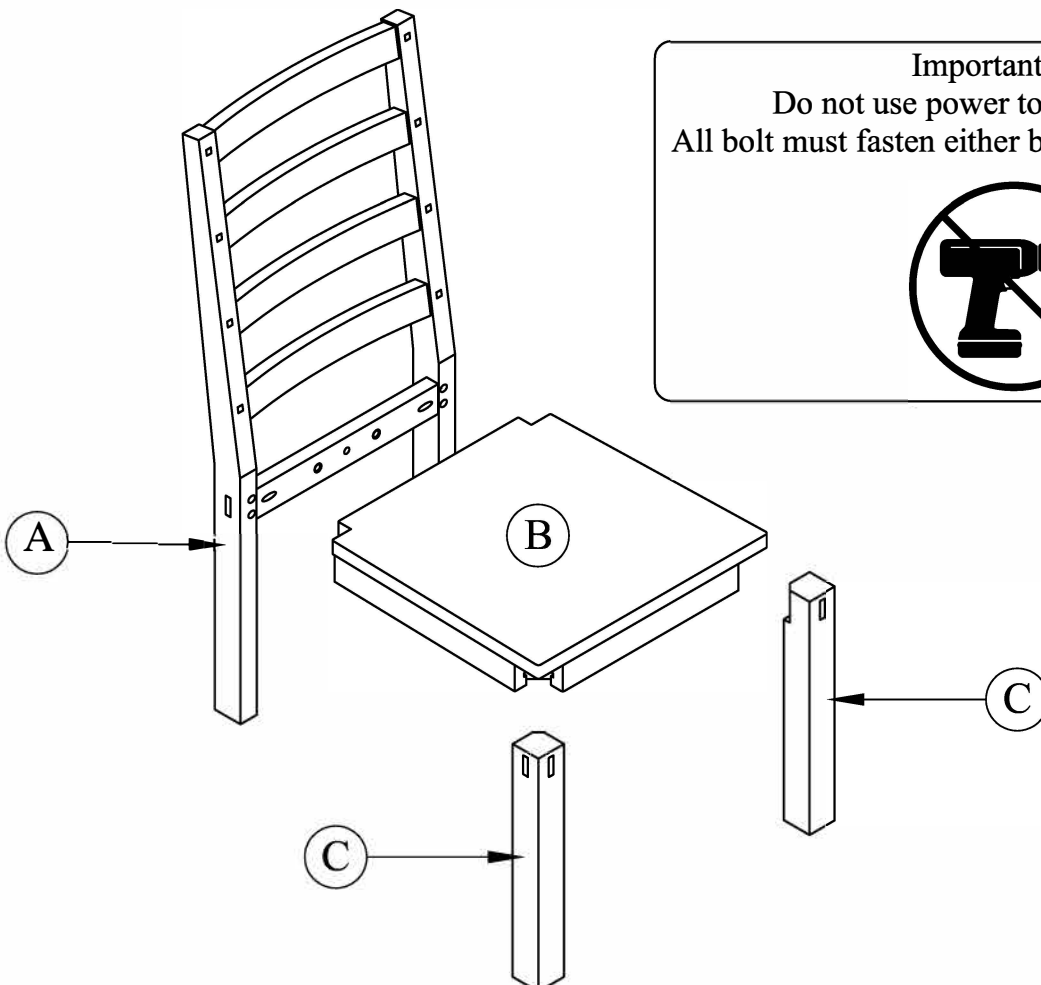

Important Note
 Do not use power tool for assembly.
 All bolt must fasten either by wrench or Allen Key.



Assembly step 1 Do not fully tighten the bolt

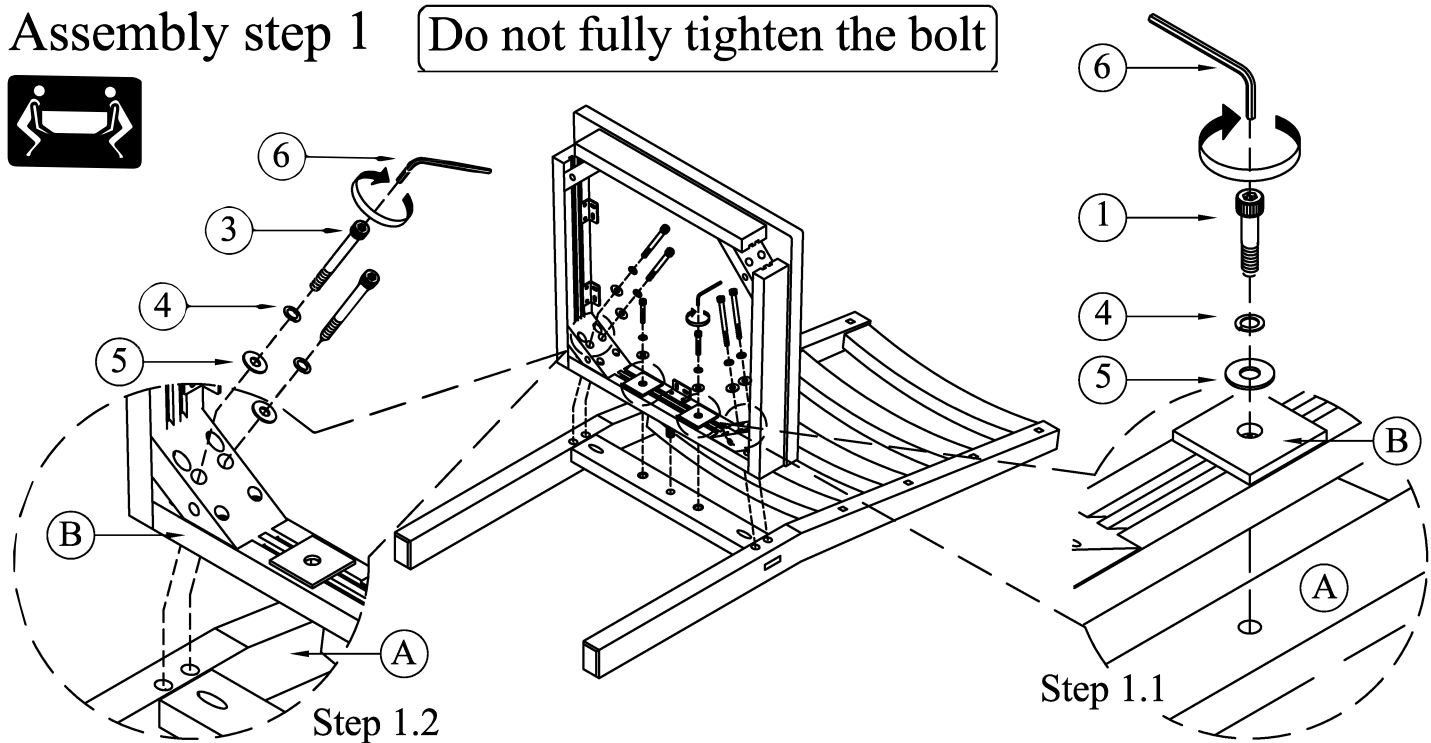

Assembly step 2 Do not fully tighten the bolt

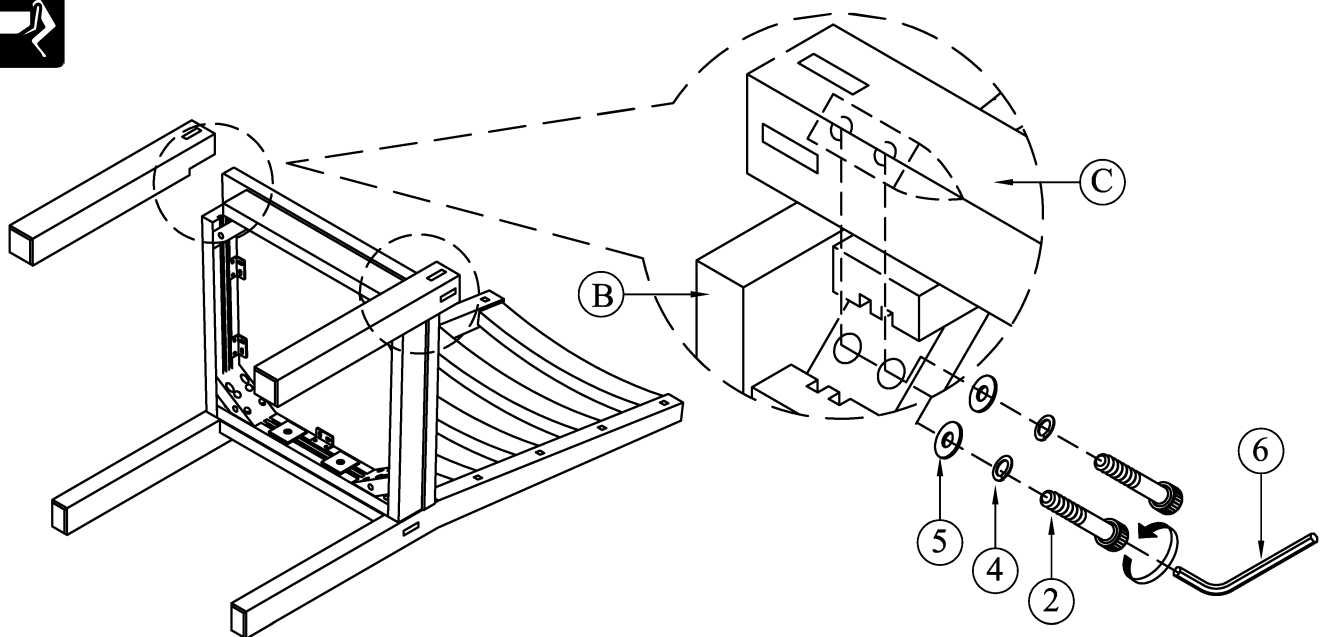

Assembly step 3 Assembly Completed

Levelling solution: Loosen each bolt in the seat box (front legs, back corner blocks and back apron) to the point where it can be turned with our fingers. Place the Chair upright on the floor and make sure Chair/Stool back and seat frame are well connected. Sit in the Chair/Stool, but do not lean against the Chair/Stool back. Gently sway back and forth, left and right. Carefully turn the Chair/Stool upside down, and tighten each bolt. The Chair/Stool will now be levelled.

