





















Item NO.:BV B12748

Hardware

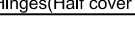
NO.	Draw	QTY	NO.	Draw	QTY
A	 Screws Ø4x14mm	72	K	 Handle(L355mm)	1
B	 Two-in-one connector	70	L	 Handle(L300mm)	2
C	 Two-in-one connector	70	M	 Screws Ø4x40mm	4
D	 Wood plug	12	N	 Screws Ø4x25mm	2
E	 Plastic anchor(Ø10mm)	2	O	 U-Shaped plastic	1
F	 Screws for fix on the wall	2	P	 Screws Ø4x20mm	4
G	 Bracket (53x70x44mm)	2	Q	 Screws Ø4x10mm	7
H	 Bracket (19x19x35mm)	2	R	 Screws M4x20mm	6
I	 Hinges(Half cover)	4	S	 Adjustable feet	6
J	 Track	2	T	 Anti-collision gasket	12
			U	 Screwdriver	1

Recommended tools

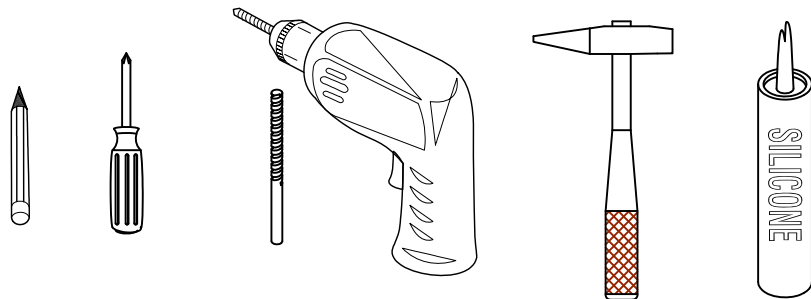

Dimensions

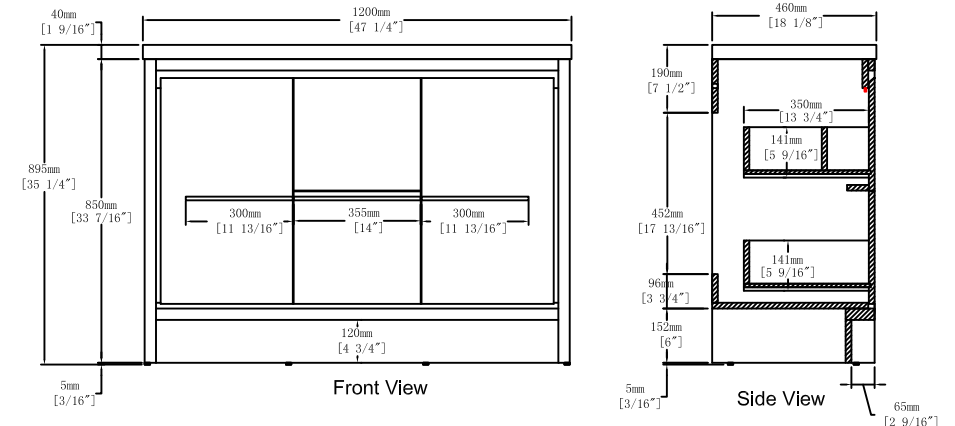

CARE CLEANING AND MAINTENANCE

1. Dust regularly with a soft , dry cloth.
2. Avoid the use of all chemicals household cleaners, abrasives, or cleaners that contain lemon, vinegar, or other acids that may damage the finish.
3. Excessive exposure to sunlight and extreme changes in temperature and moisture can damage wood furniture.
4. The sink is fragile, please pay attention to maintaining its appearance.
5. Do not place hot appliances, such as curling irons and hot hair dryers directly on the countertop. Wipe spills immediately.

Step 22

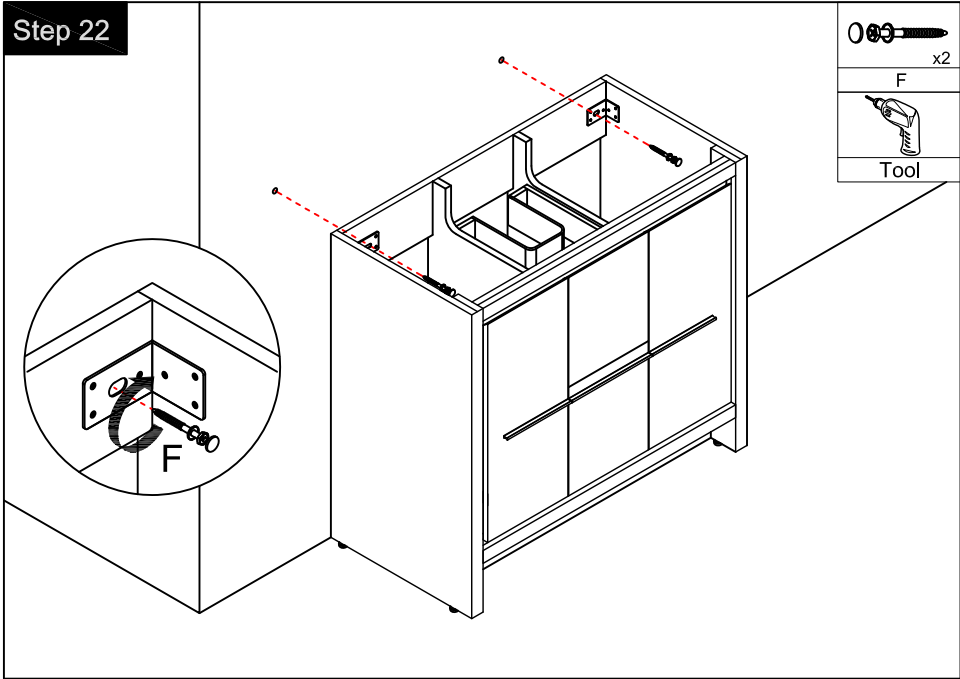

Finished

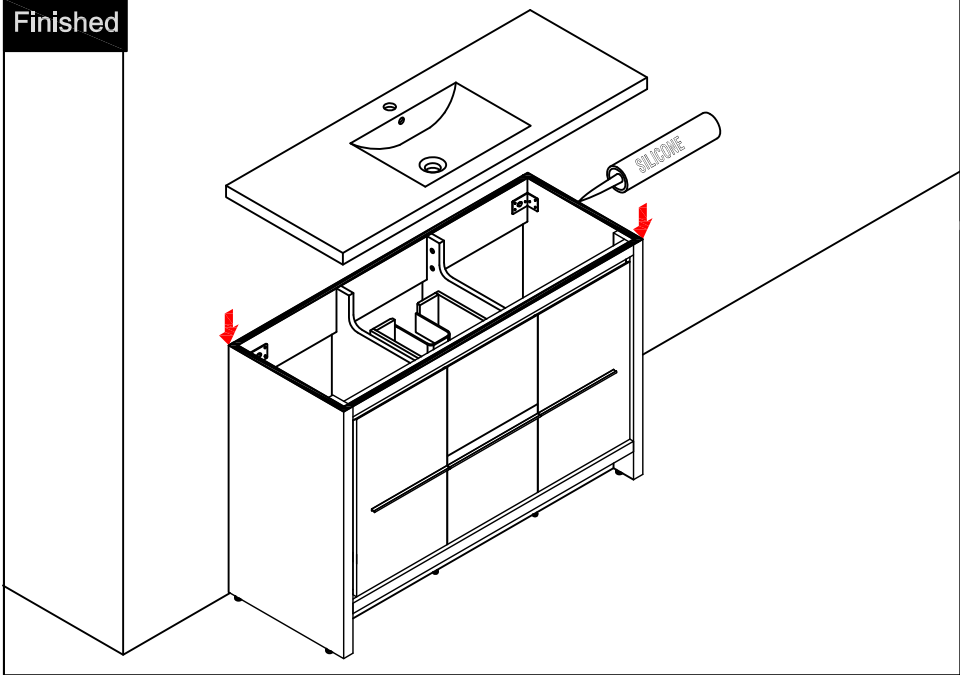

Components

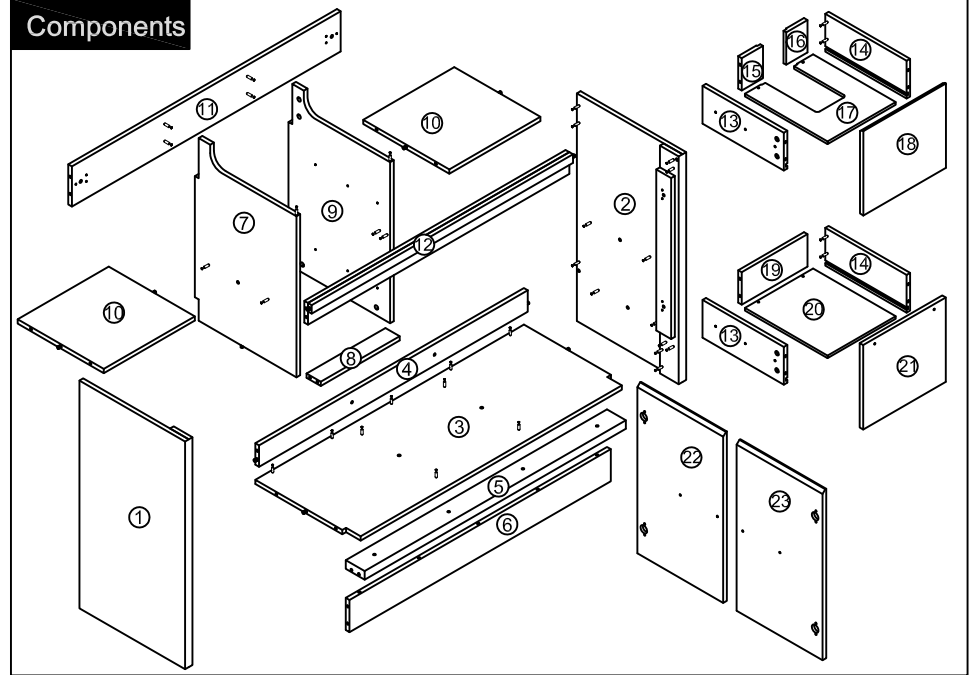

Step 1

x5
 B
 x5
 C
 U

Notes: Screw installation depth as shown

Attention: Cam lock arrow point to the steel rod.

Step 2

x5
 B
 x5
 C
 U

first step second step third step

Step 19

(L300mm)
 x2
 L
 (M4 x 20mm)
 x4
 R
 x4
 T
 Tool
 Tool

Step 20

Tool
 Tool

x2
 E
 Tool

Step 17

Notes: Pull out the tracks on the cabinet body and push them into the upper and lower drawers as shown in the diagram. The drawer tracks are interlocked with the cabinet body tracks.

Step 18

You can adjust the doors by tightening or loosening the screws on the hinge.

Step 3

Note: The D parts are used for these two holes

Step 4

Step 5

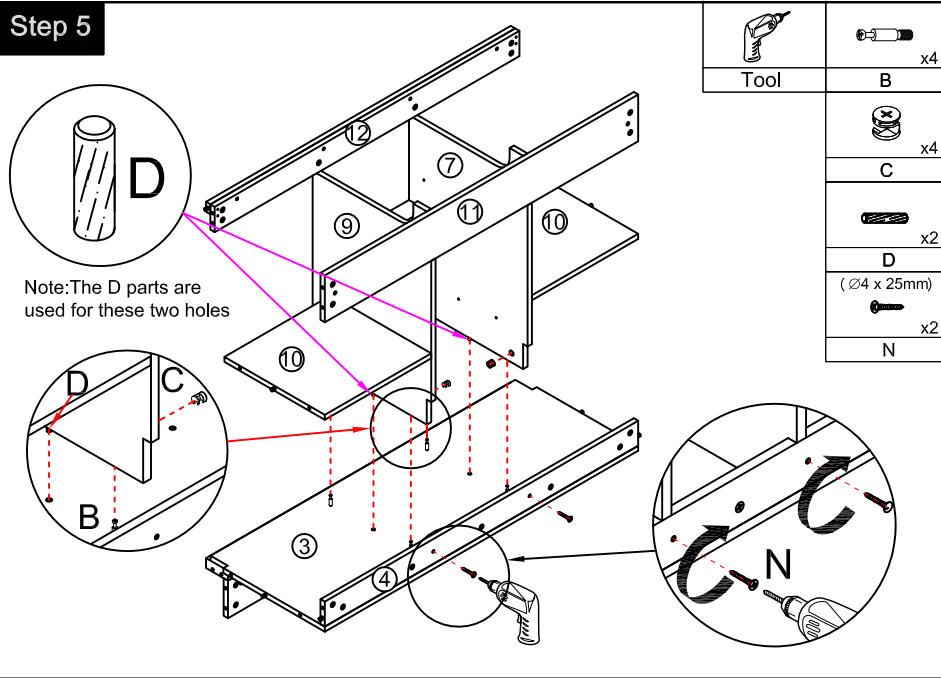

Step 15

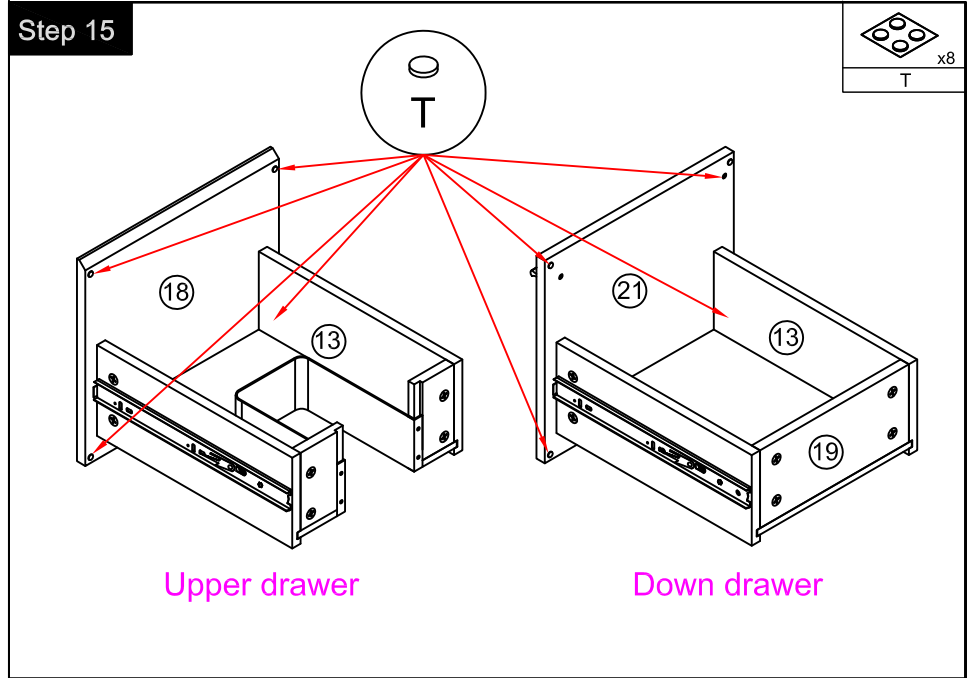

Step 6

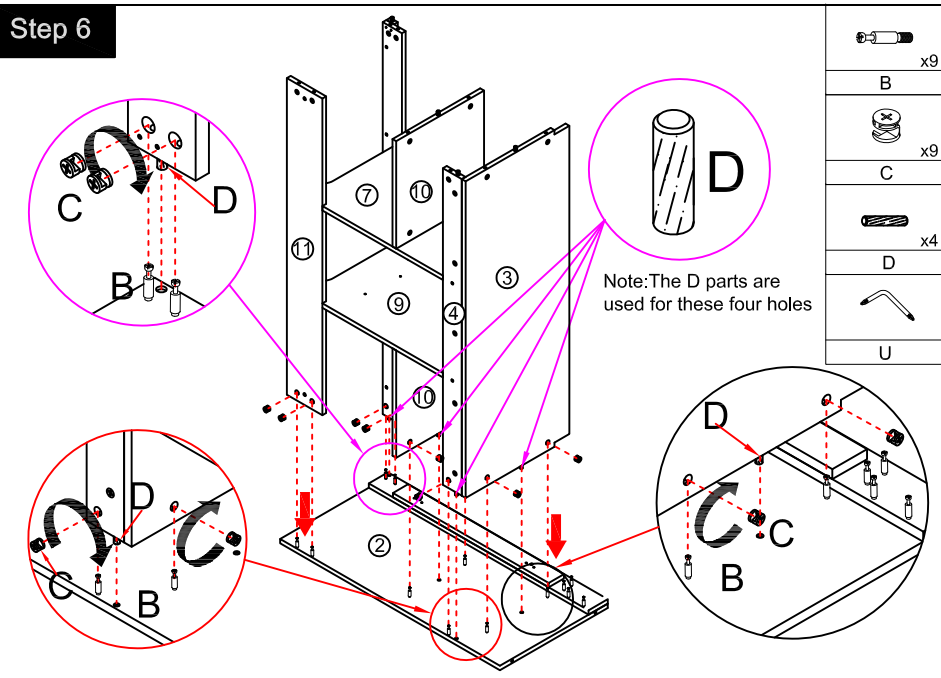

Step 16

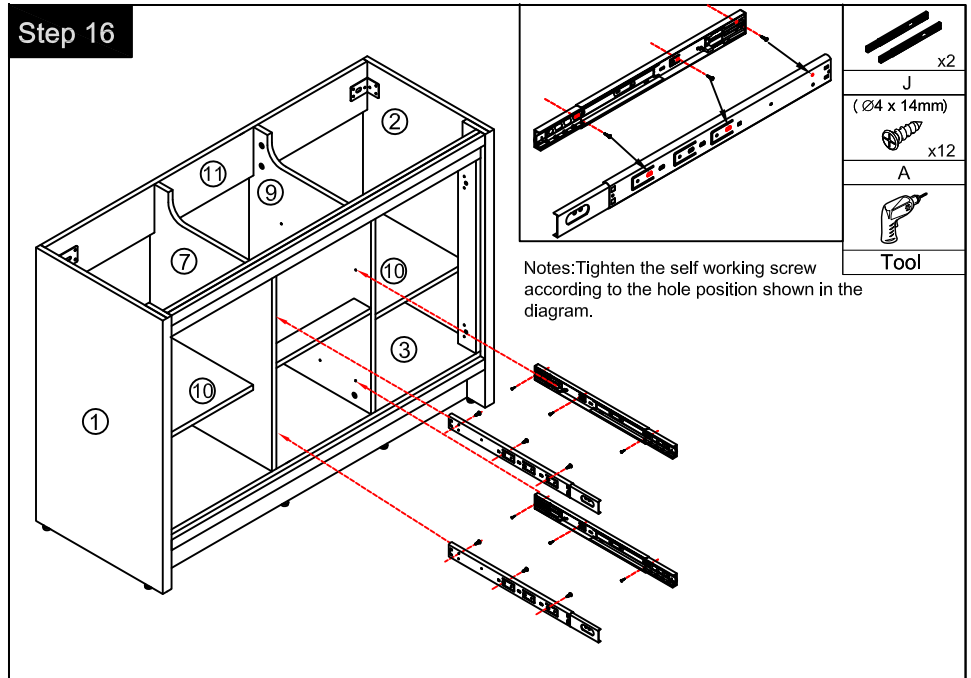

Step 13

Notes: Disassemble the three fold side mounted buffer rail as shown in the following diagram.

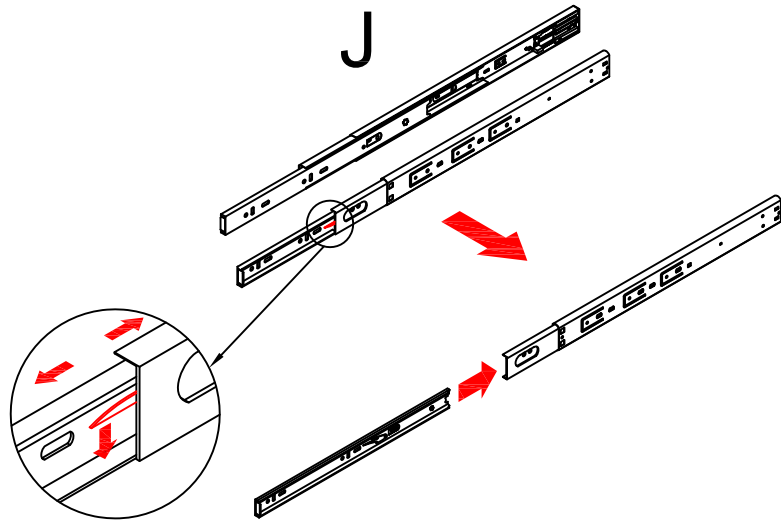

Step 14

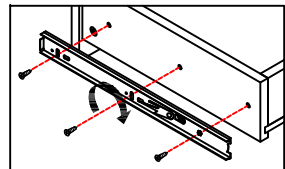

Notes: Install the dismantled side mounted rail as shown in the diagram.

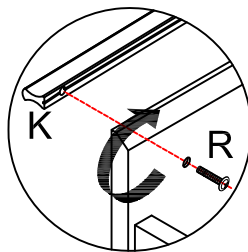

(M4 x 20mm)		x2		x2
	R		J	
			(Ø4 x 14mm)	
		x12		
			A	
			(L355mm)	
		x1		
			K	
			Tool	

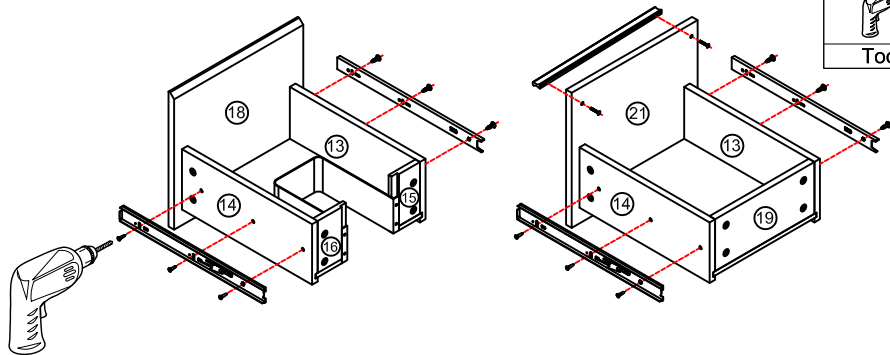

Step 7

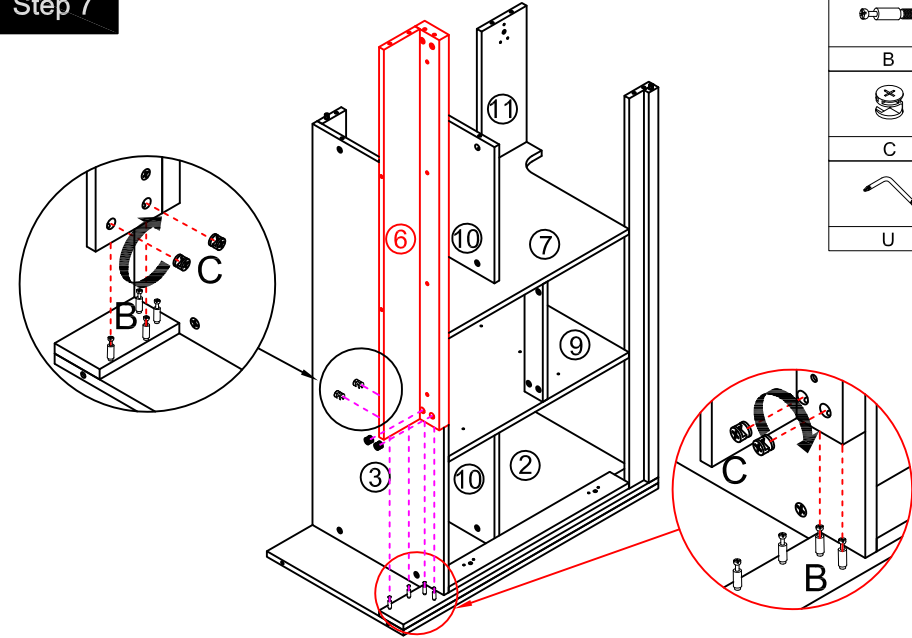

	x4
B	
	x4
C	
U	

Step 8

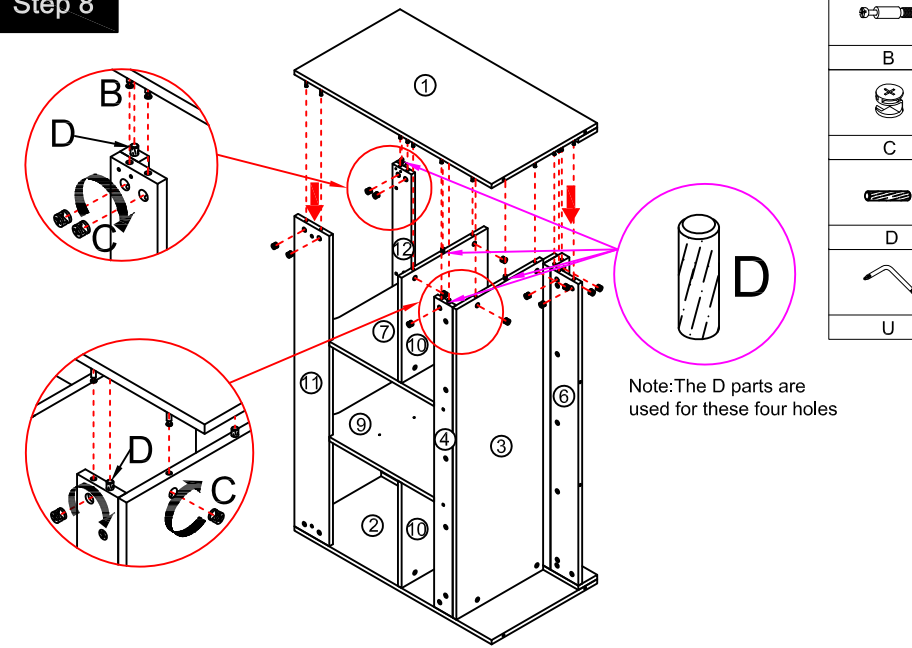

	x13
B	
	x13
C	
	x4
D	
U	

Note: The D parts are used for these four holes

