

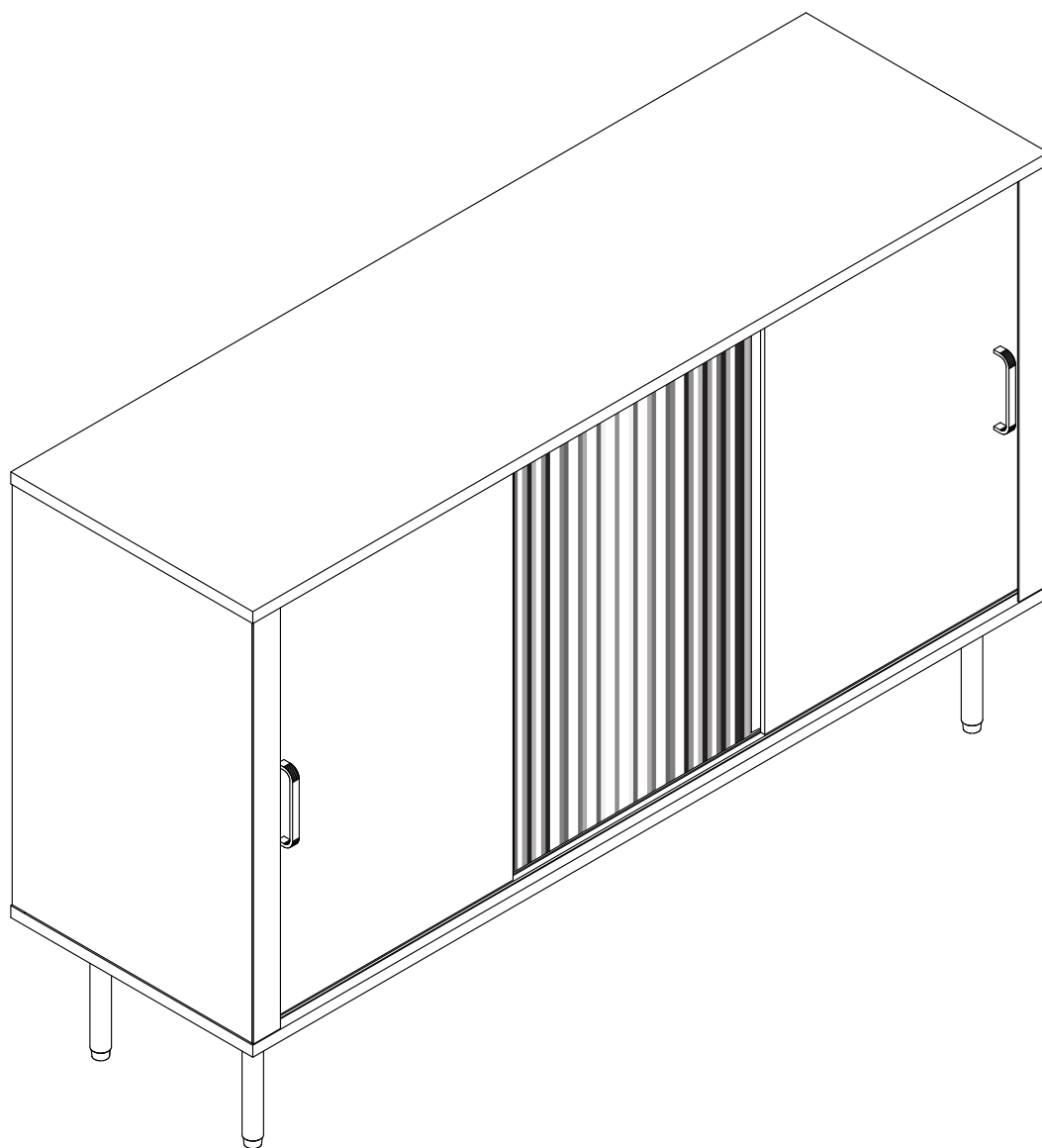





**ASSEMBLY INSTRUCTIONS / INSTRUCTIONS
D'ASSEMBLAGE / INSTRUCTIVO DE ARMADO**



NOTES ON ASSEMBLY / NOTES POUR L'ASSEMBLAGE / NOTAS SOBRE EL ENSAMBLE

- To ensure ease of assembly read all instructions before assembly and follow step by step illustrations.
- Keep instructions for future use.
- Adult assembly required.  2 person required. 
- Due to the presence of small parts during assembly, keep out of reach of children until assembly is complete.

- Pour assurer l'assemblage facile veuillez lire toutes les instructions avant l'assemblage et veuillez suivre les illustrations pour chaque étapes.
- Veuillez garder ces instructions pour l'usage ulterieur.
- Assemblage requis pas un adulte.  2 personnes requises. 
- Due a la presence de petite pieces durant l'assemblage, veuillez garder hors de porter des enfants jusqu'a ce que l'assemblage soit completer.

- Para garantizar la facilidad de ensamble lea las instrucciones antes de iniciar y siga paso a paso las ilustraciones.
- Guarde las instrucciones para futuras referencias.
- El ensamble requiere de un adulto.  2 personas requeridas. 
- Debido a que hay piezas pequeñas, mantenga fuera del alcance a los niños durante el ensamble, hasta que haya terminado.

MAINTENANCE TIPS / CONSEILS D'ENTRETIEN / CONSEJOS DE MANUTENIMIENTO

- Never let liquids or damp cloths sit on this furniture.
- Never use chemical cleaning products. They can damage the finish. For cleaning, use only a slightly damp cloth and wipe dry.
- To avoid dulling of the finish, do not place furniture in direct sunlight.
- Do not put plastic or rubber rings under appliances. Use cloth of felt protectors.
- To clean, use a soft or slightly damp cloth, then wipe with a clean, dry cloth.

- Ne jamais laisser de liquide ou linge humide sur le meuble.
- Ne jamais utiliser de nettoyeurs à base de produits chimiques, cela va endommager le fini. Utiliser seulement un linge légèrement humide.
- Ne pas placer le meuble directement au soleil pour prévenir le ternissement.
- Évitez de déposer des appareils avec des rondelles de plastique ou de caoutchouc. Utilisez un protecteur en tissu ou en feutre.
- Pour nettoyer, utilisez un linge doux ou légèrement humecté. Essuyez par la suite avec un linge propre et sec.

- Nunca deje un líquido o un trapo húmedo sobre el mueble.
- Nunca utilice limpiadores a base de químicos, estos dañaran le acabado. Use sólo un paño húmedo.
- No esponga el mueble directamente al sol para prevenir empañamiento.
- Evite apoyar aparatos con redondeles de plástico o de goma. Utilizar un protector de tela o de fieltro.
- Para limpiar, utilice un trapo suave o ligeramente humedecido. Seque luego con un trapo limpio y seco.

WARNING AVERTISSEMENT / ADVERTENCIA

Serious or fatal crushing injuries can occur from furniture tip-over.

To help prevent tip-over:

- Place heaviest items in the lowest drawers.
- Do not set TVs or other heavy objects on the top of this product. Never allow children to climb or hang on drawers, doors, or shelves.
- Never open more than one drawer at a time.
- Always monitor your child's activity when in the nursery.
- Do not allow standing in drawers.
- Do not allow standing on top of this product.
- Accessory Items must be securely fastened to this product according to the instructions provided with those items.
- To avoid head injury, do not allow children to play underneath open drawers.
- Do not leave drawers open when not in use.

Use of tip-over restraints reduce, but does not eliminate, the risk of tip-over.

Des blessures graves ou fatales peuvent résulter du basculement du meuble.

Afin d'éviter le basculement :

- Placer les items les plus lourds dans les tiroirs du bas.
- Ne pas placer de TV ou d'autres objets lourds sur ce produit. Ne jamais laisser un enfant grimper sur les tiroirs, les portes et les tablettes ou s'accrocher à ceux-ci.
- Ne jamais ouvrir plus d'un tiroir à la fois.
- Toujours surveiller votre activité de l'enfant lorsqu'à la pépinière.
- Ne pas laisser debout dans des tiroirs.
- Ne pas laisser debout sur ce produit.
- Les accessoires doivent être solidement fixés sur ce produit selon les instructions fournies avec ces éléments.
- Pour éviter toute blessure à la tête, ne pas laisser les enfants jouer sous les tiroirs ouverts.
- Ne pas laisser ouvrir les tiroirs lorsqu'il n'est pas utilisé.

L'utilisation de dispositif antibasculement ne peut que réduire les risques de basculement, sans les éliminer totalement.

El vuelco del mueble puede ser causa de lesiones graves o de un aplastamiento fatal.

Para evitar el vuelco:

- Ponga las cosas pesadas en los cajones más bajos.
- No ponga televisores u otros objetos pesados encima de este producto. Nunca permita que un niño se trepe o se cuelgue en cajones, puertas o estantes.
- Nunca abra más de un cajón a la vez.
- Siempre supervisa la actividad de su hijo cuando en el vivero.
- No dejar reposar en los cajones. .
- No permiten de pie en la parte superior de este producto.
- Los elementos accesorios deben sujetarse firmemente a este producto de acuerdo a las instrucciones provistas con esos elementos.
- Para evitar lesiones en la cabeza, no permita que los niños jueguen debajo abrir cajones.
- No deje los cajones abiertos cuando no está en uso.



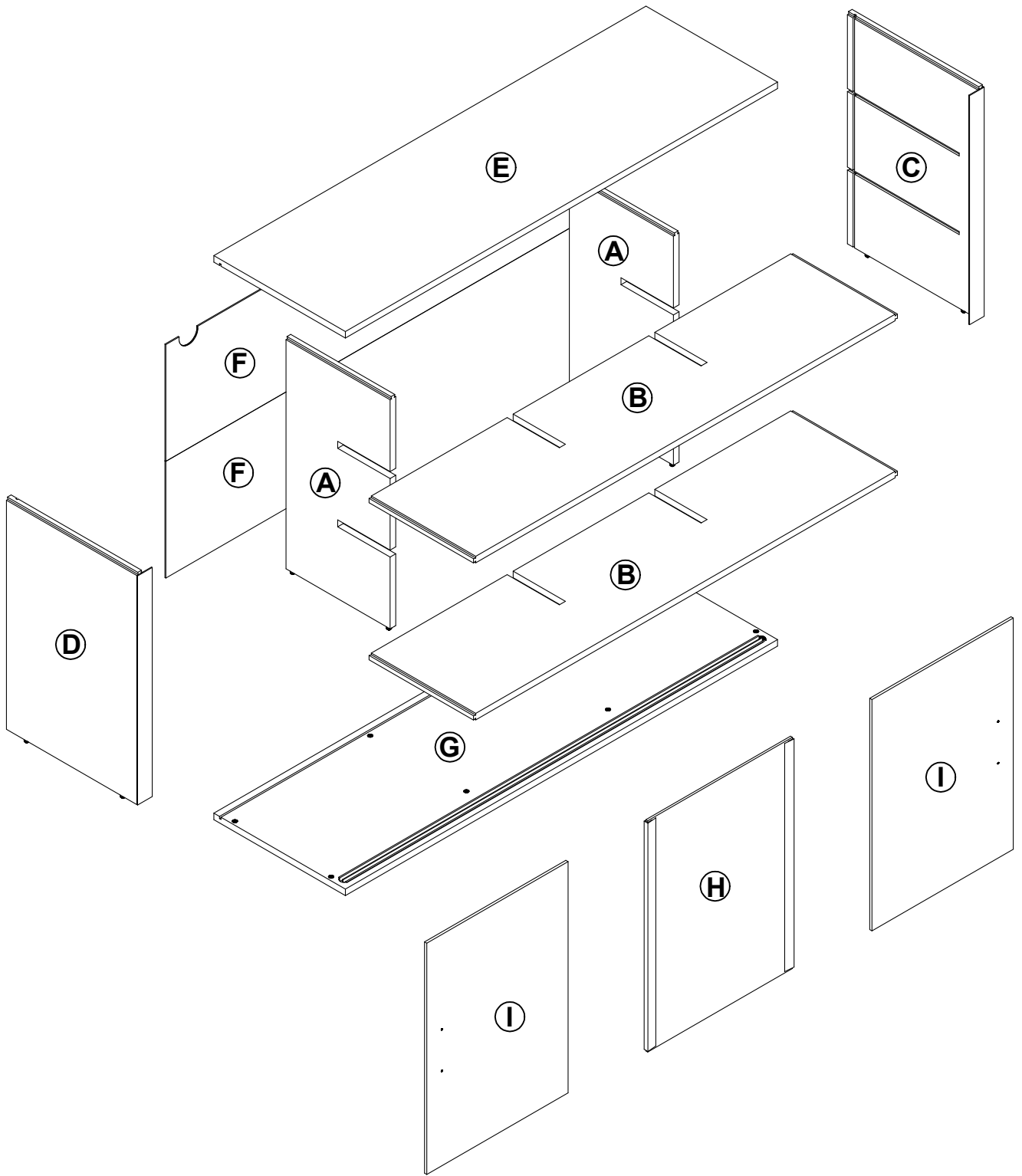

El uso de sujetadores para evitar el vuelco sólo puede disminuir el riesgo de un vuelco, pero no lo elimina.

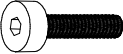
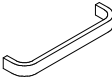
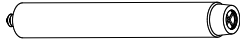

HARDWARE QUINCAILLERIE / HERRAJE

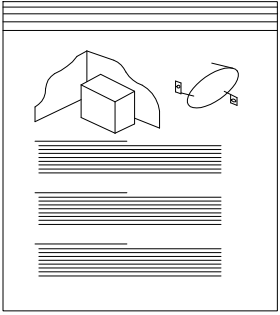
(A)	Screw 12mm	(B)	Handle	(C)	Leg
					
	4 units		2 units		5 units

FURNITURE TIPPING RESTRAINT SEGURO CONTRA VOLCADO DE MUEBLES DISPOSITIF DE SÉCURITÉ POUR MEUBLES

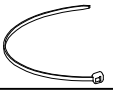
	➔	(E)	Screw 2"	(F)	Screw 5/8"
					
			2 units		2 units
		(G)	Bracket	(H)	Restraint Strap
					
			4 units		2 units

TOOLS NOT INCLUDED OUTILS PAS INCLUS / HERRAMIENTAS NO INCLUIDAS

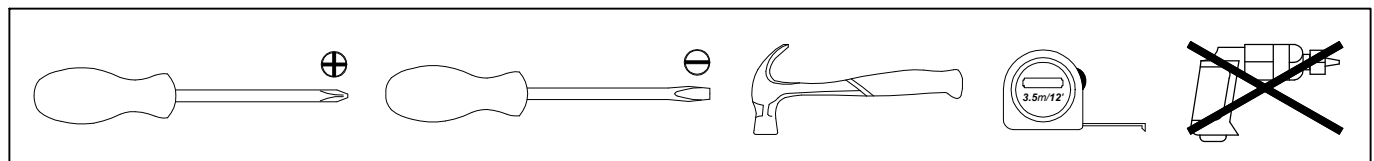

STEP 1

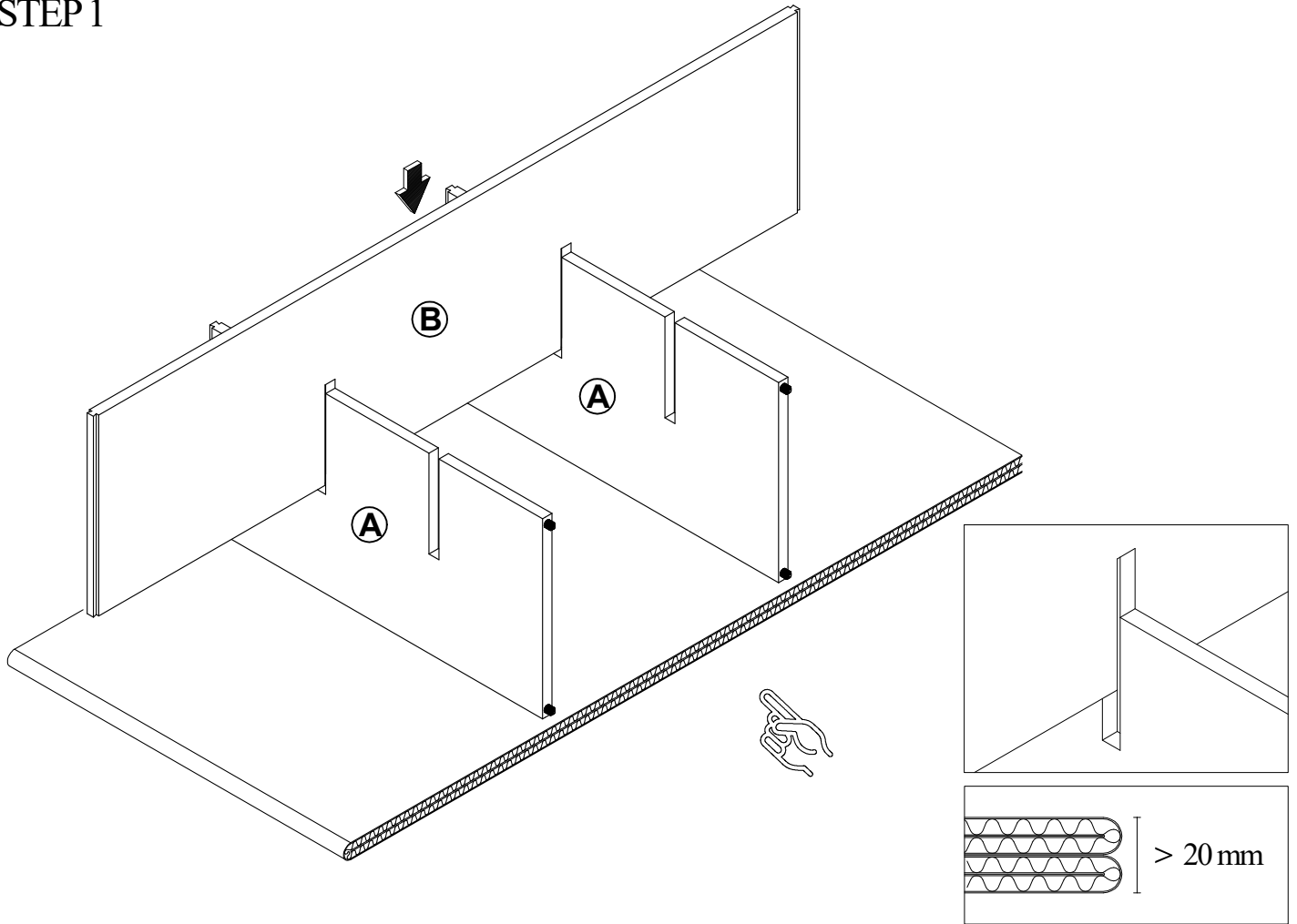

STEP 2

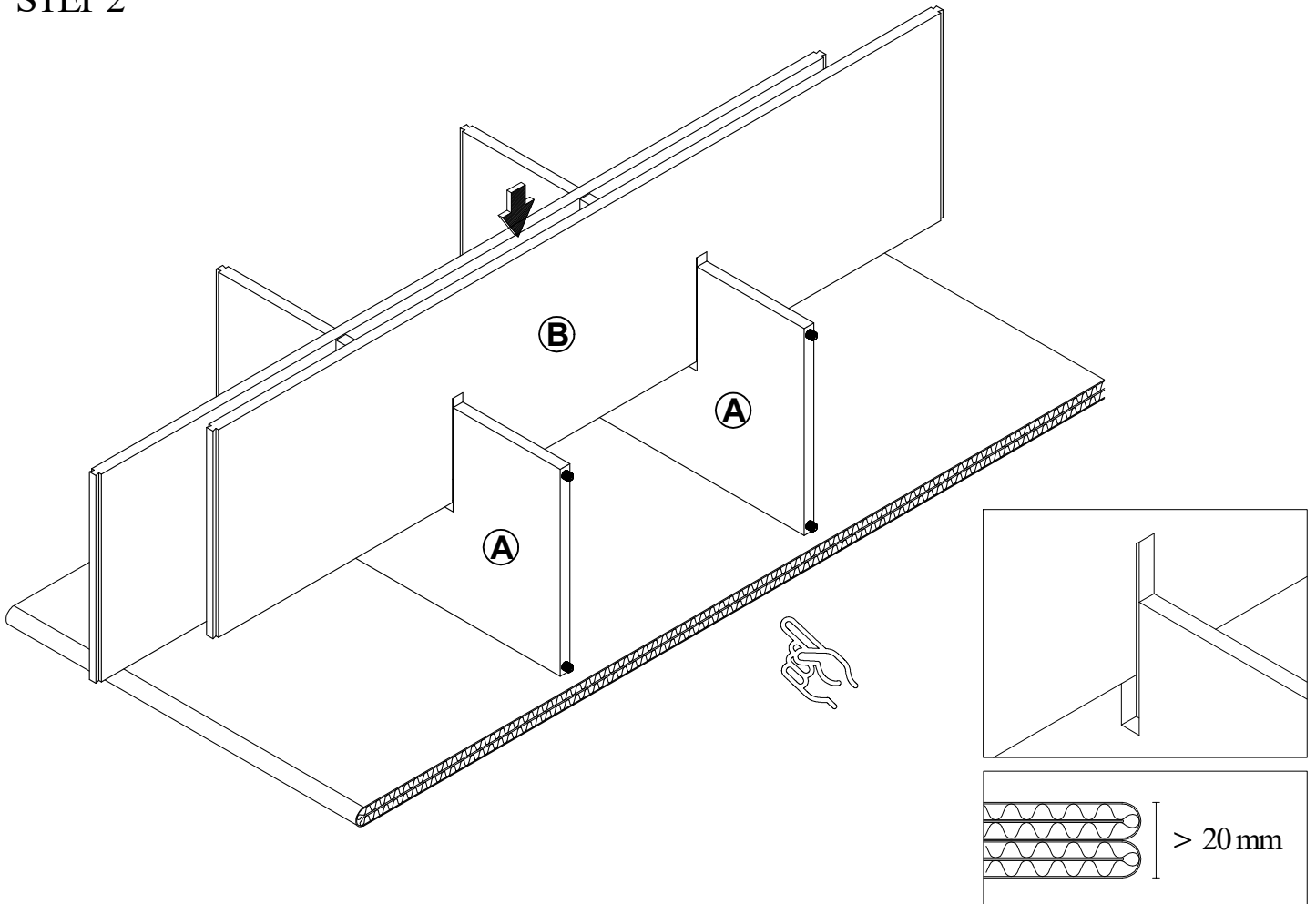

STEP 3

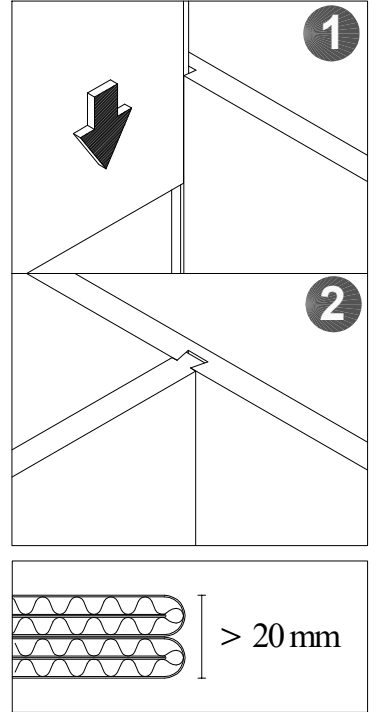
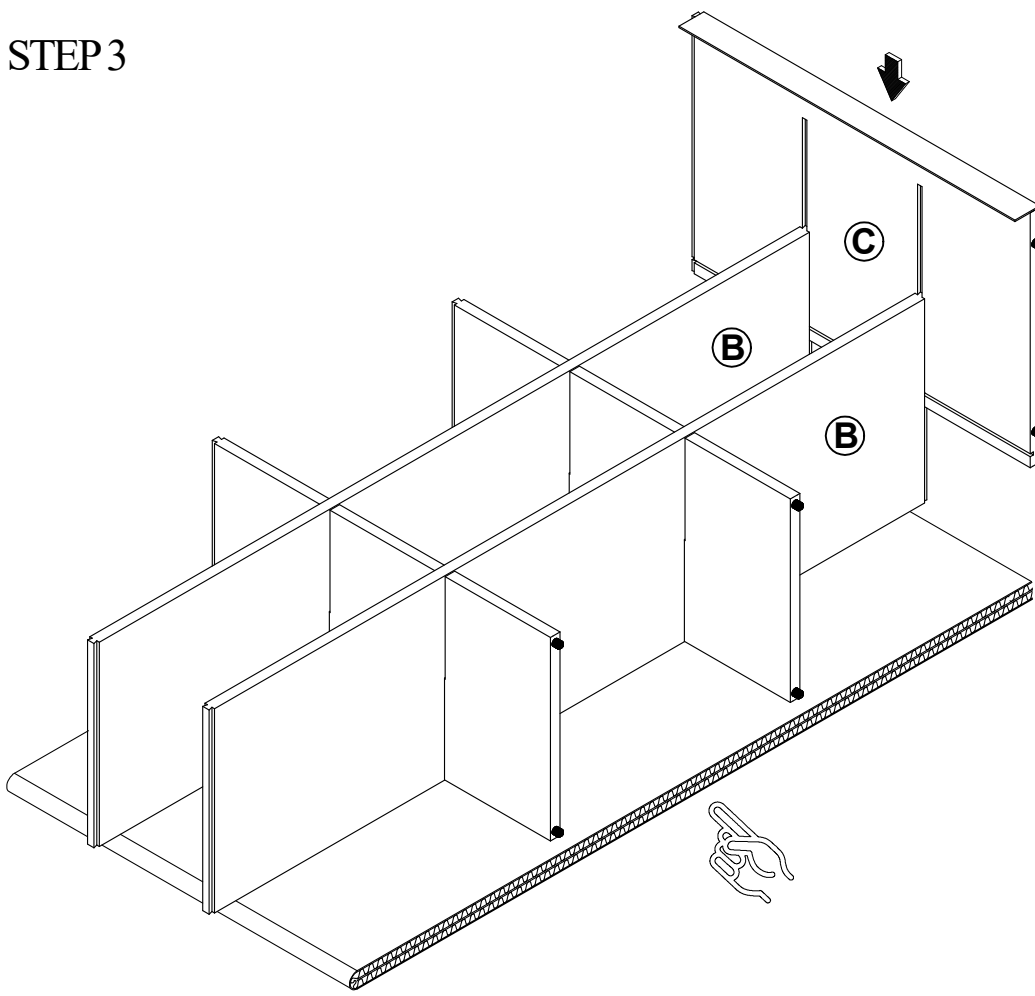

STEP 4

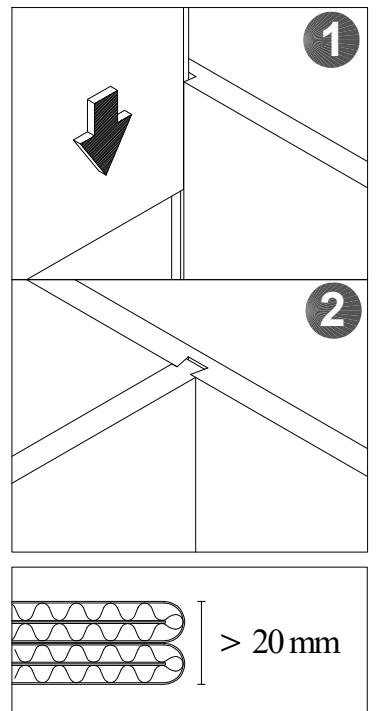
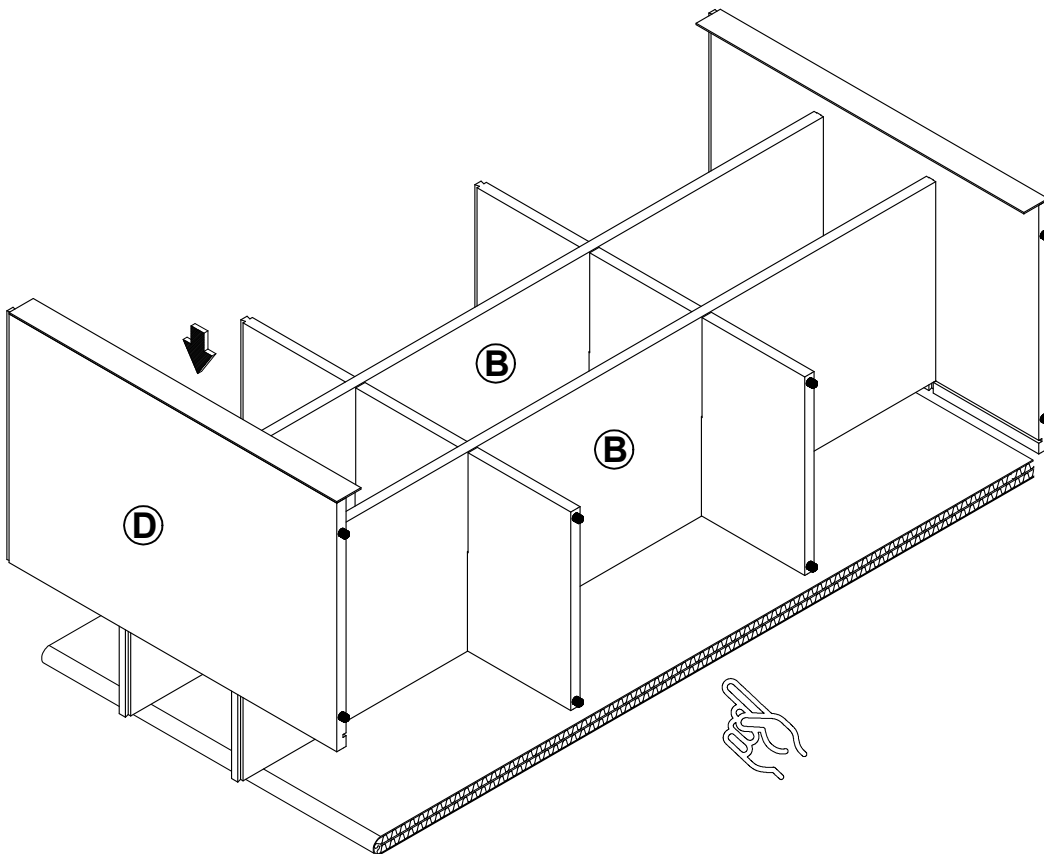

STEP 5

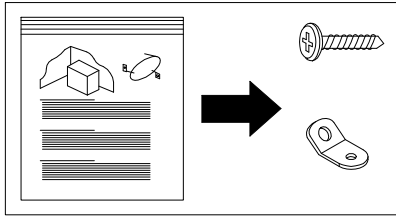

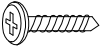
	
G x 2	F x 2

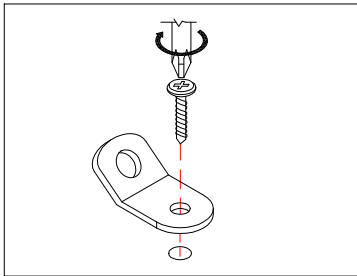
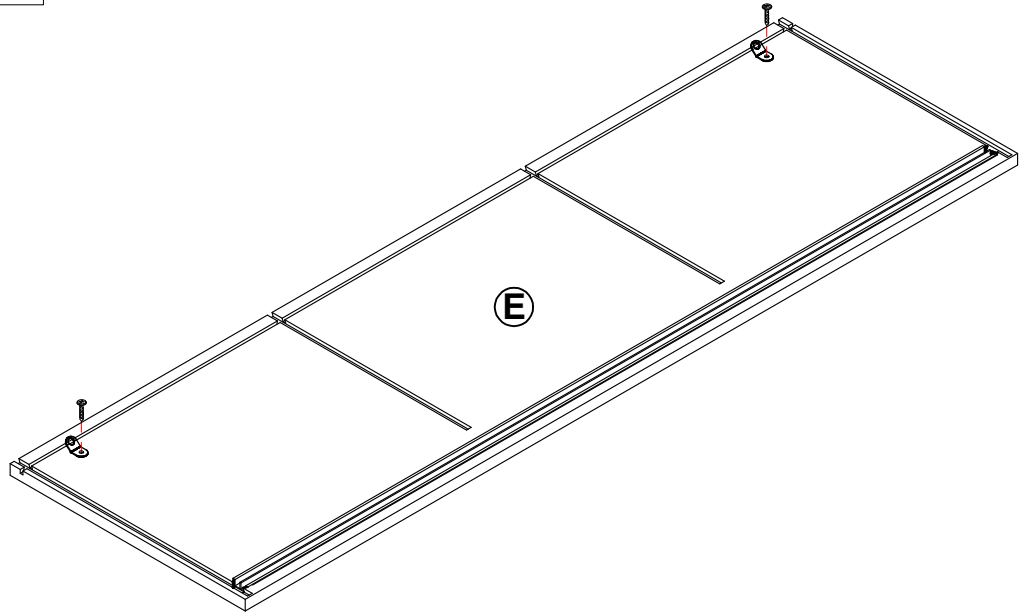

STEP 6

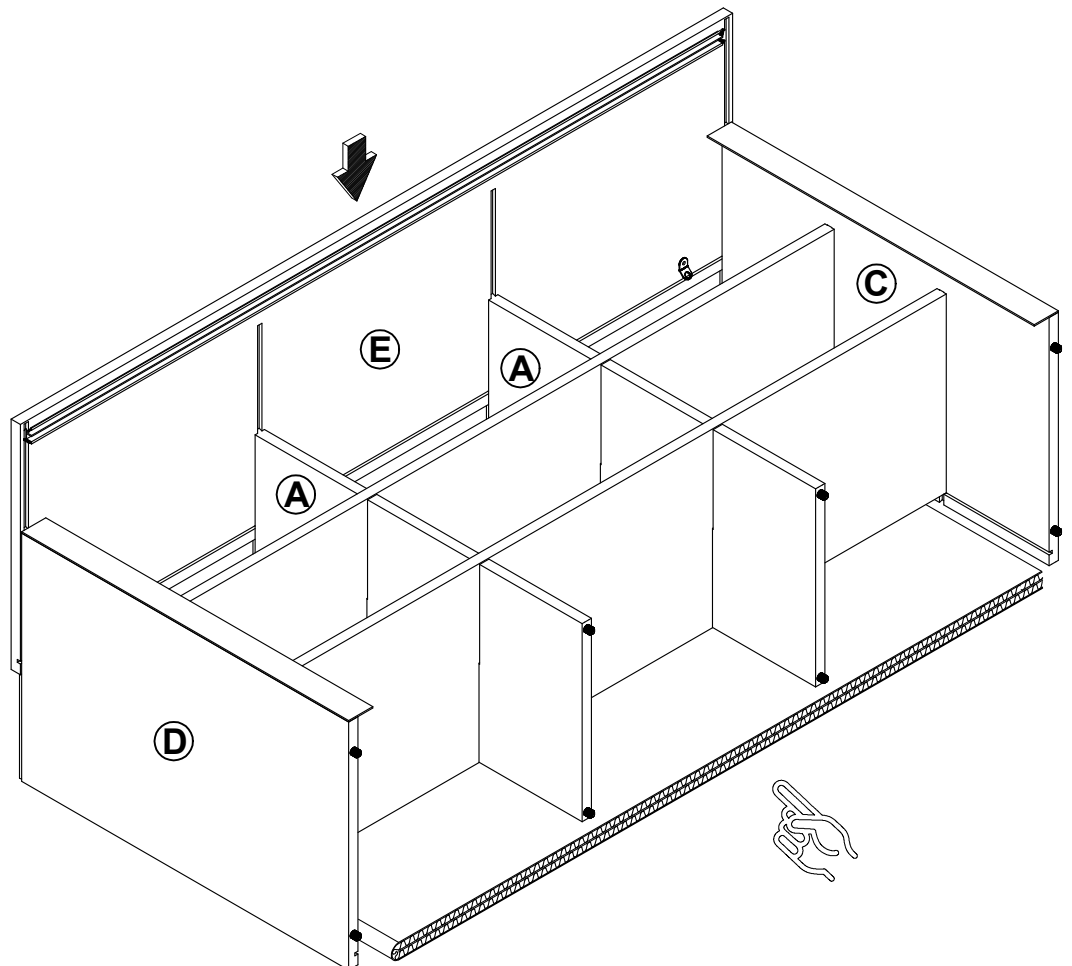
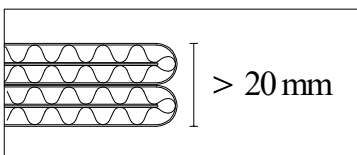
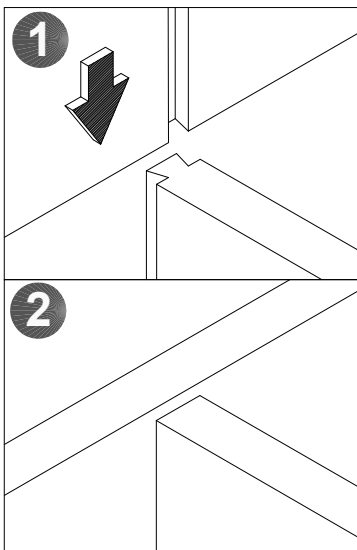

STEP 7

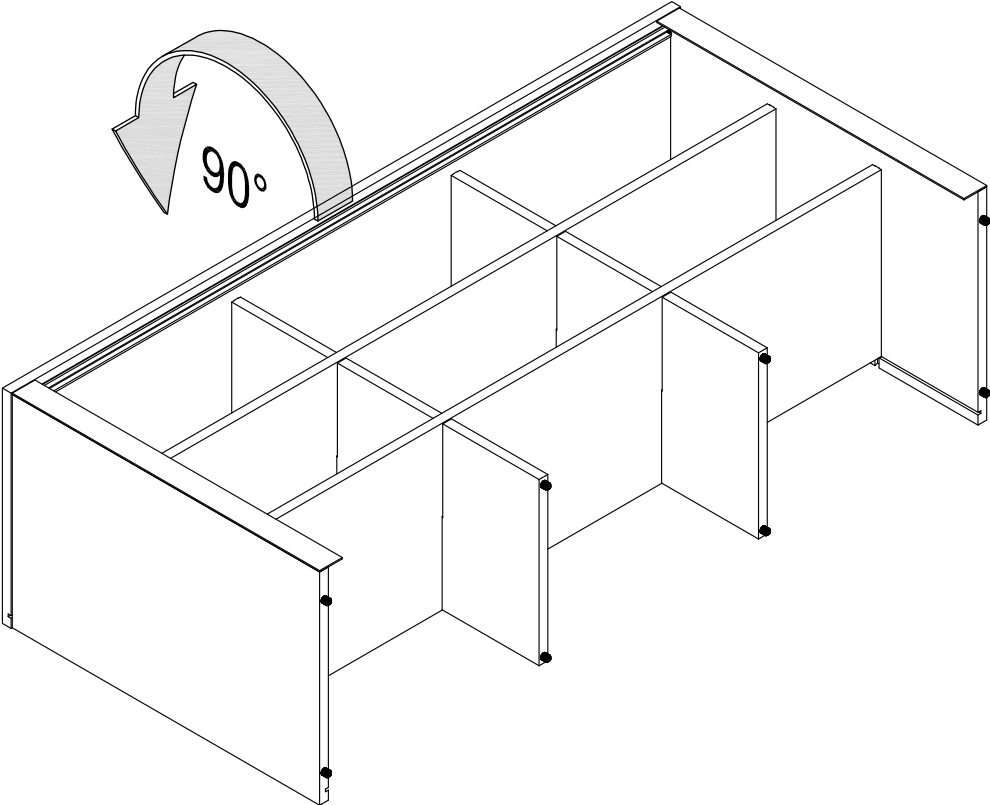

STEP 8

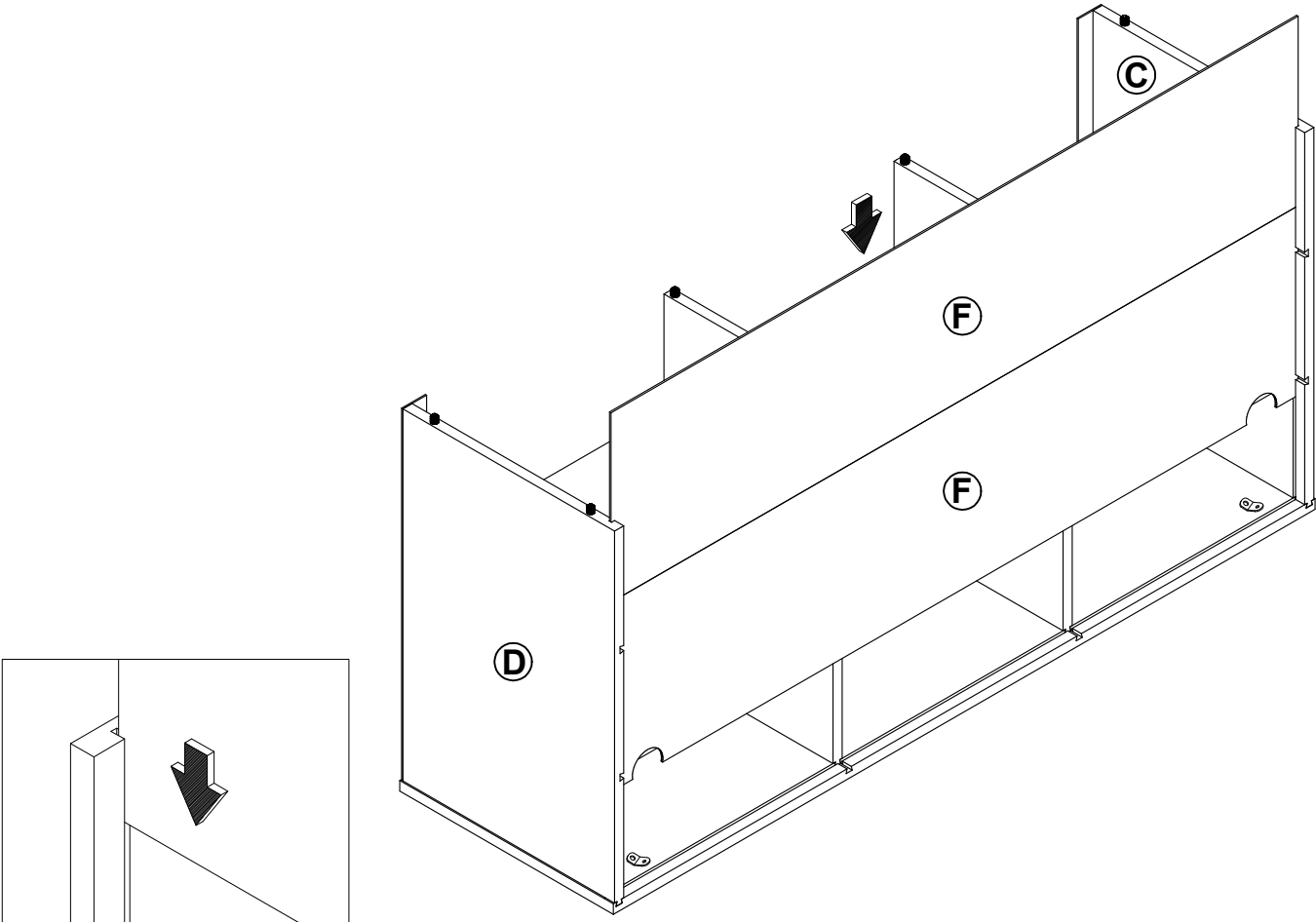

STEP 9

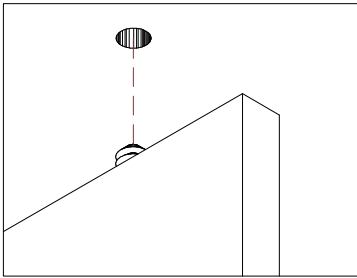
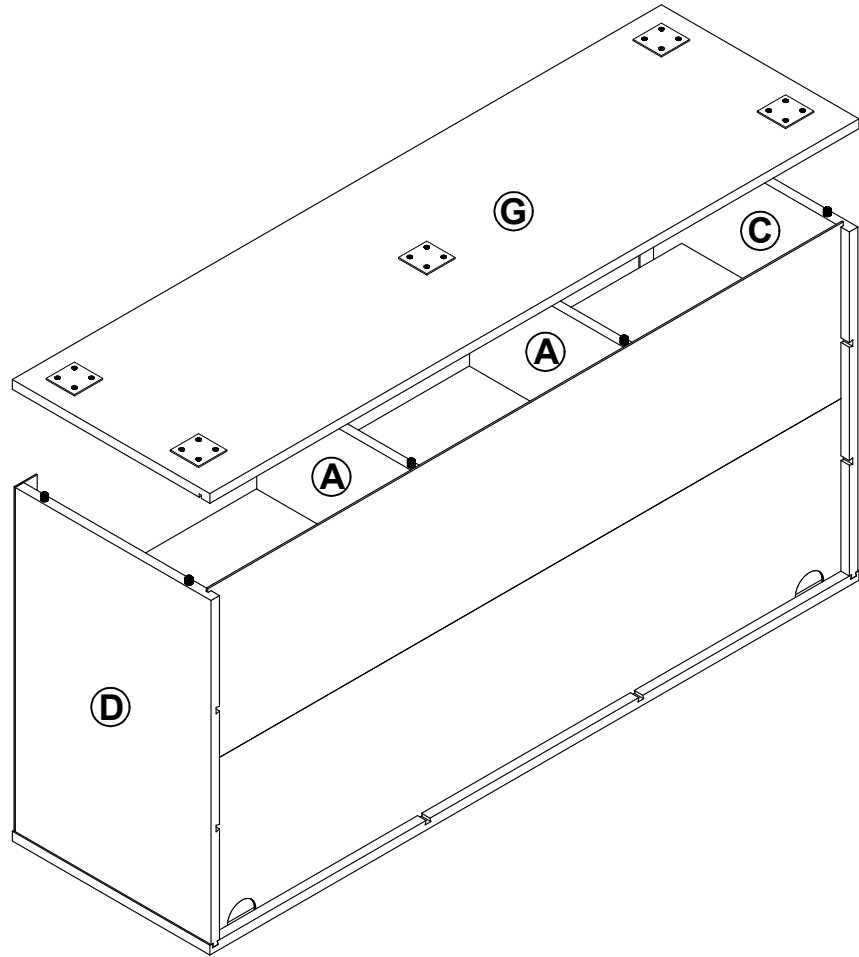

STEP 10

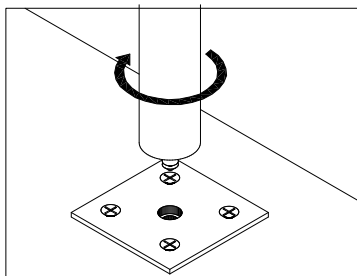
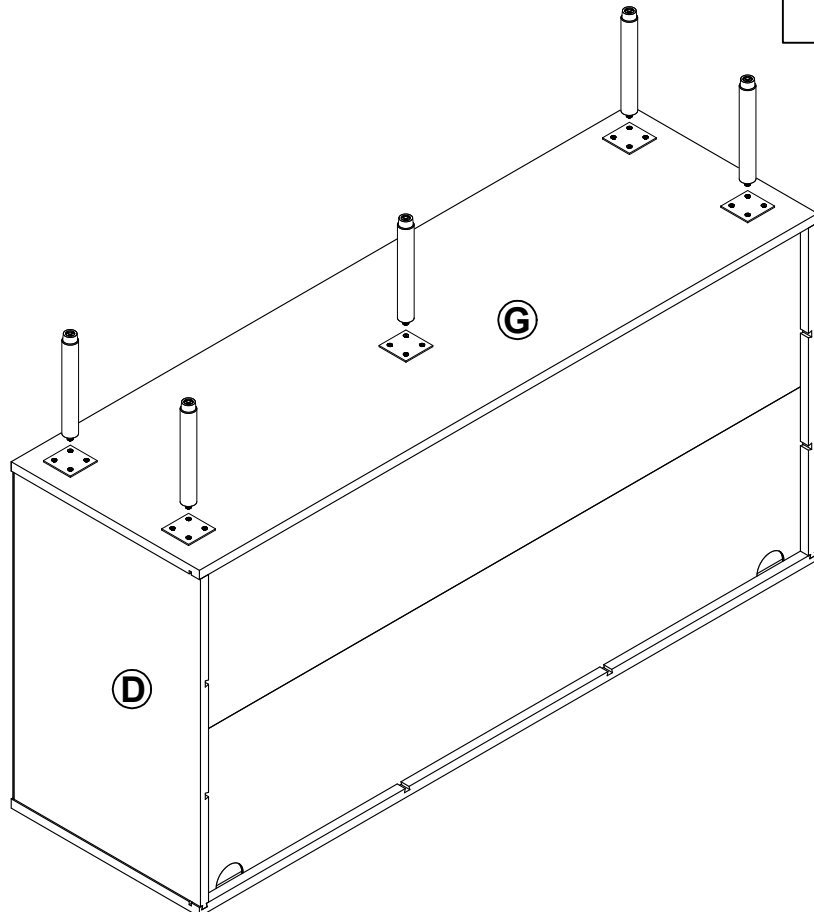
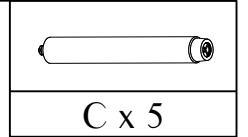

STEP 11

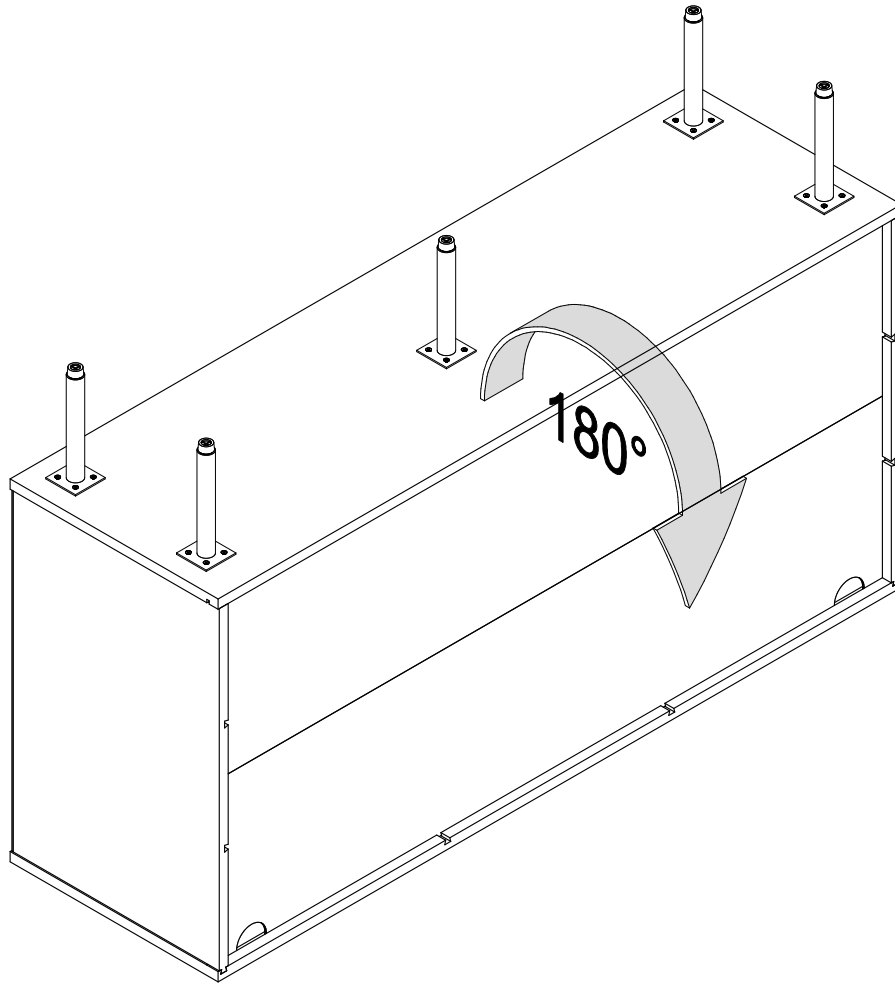

STEP 12

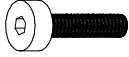
	
B x 2	A x 4

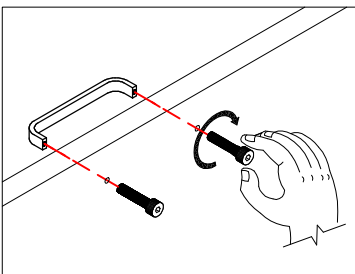
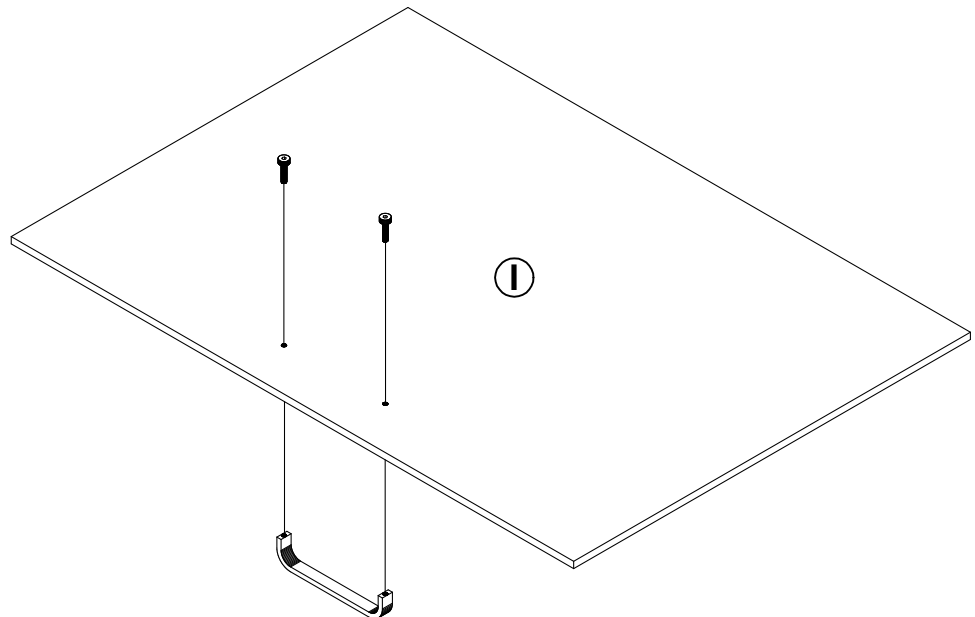

(2x)

STEP 13

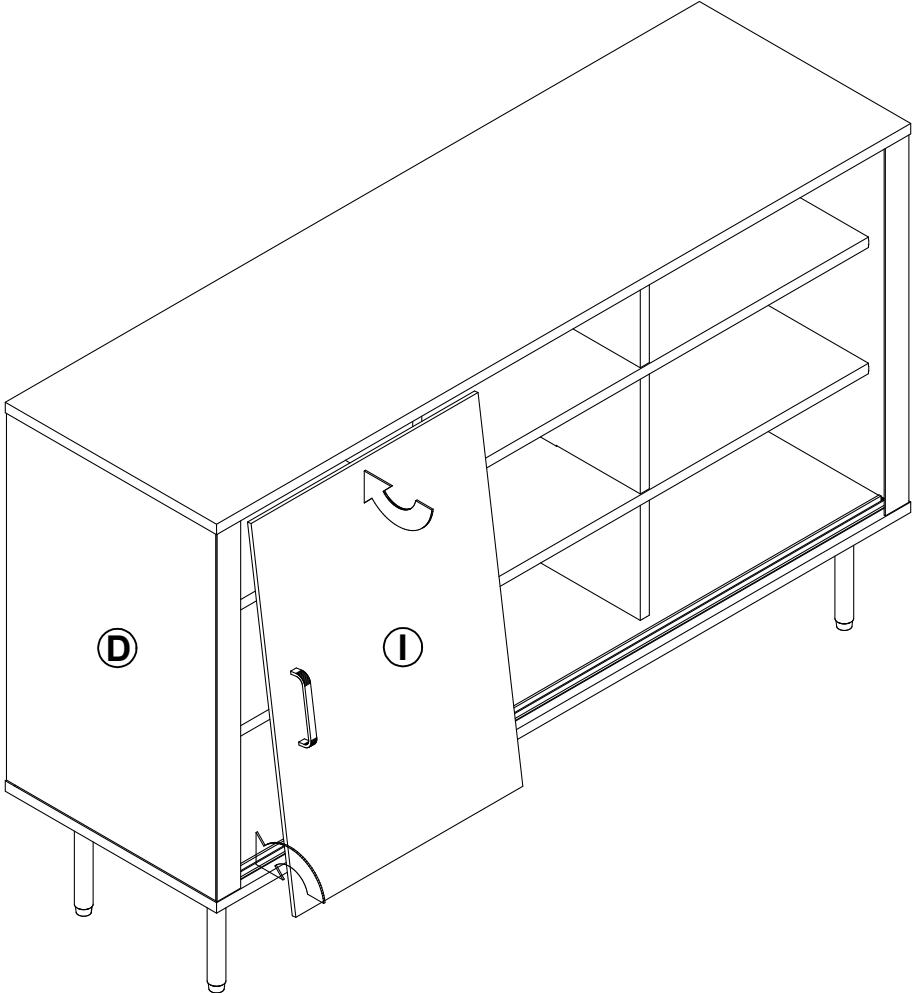

STEP 14

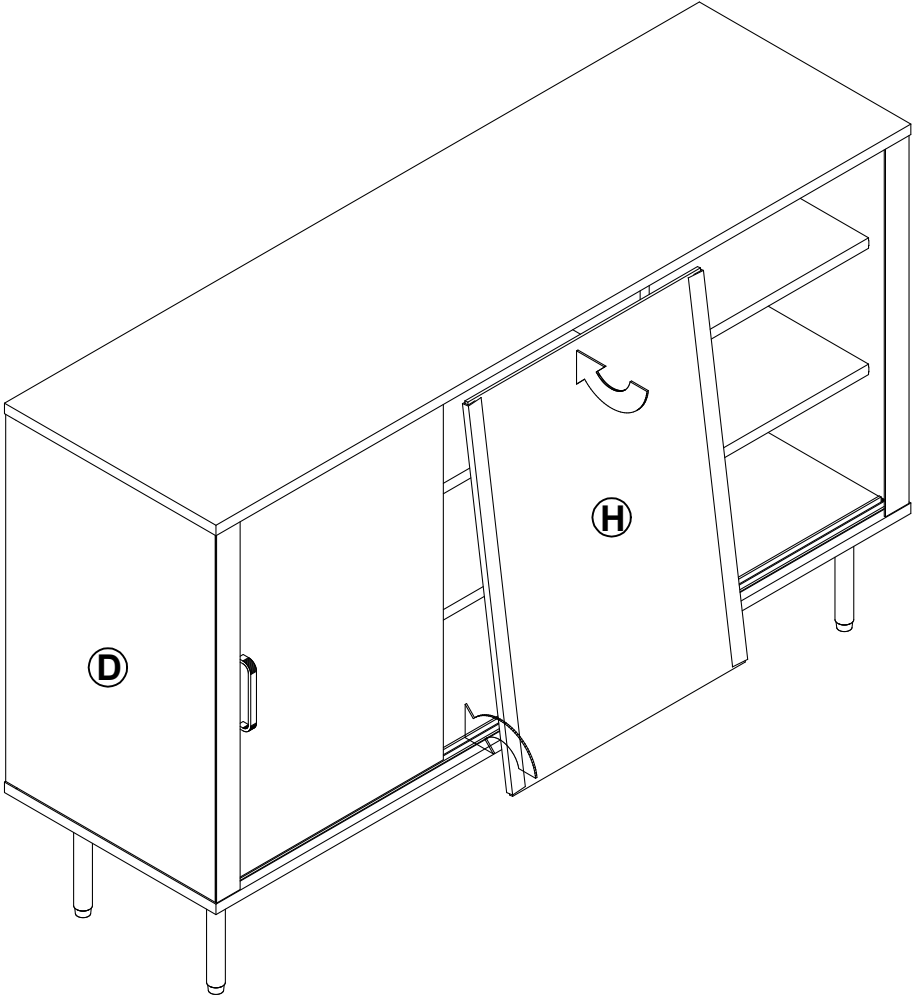

STEP 15

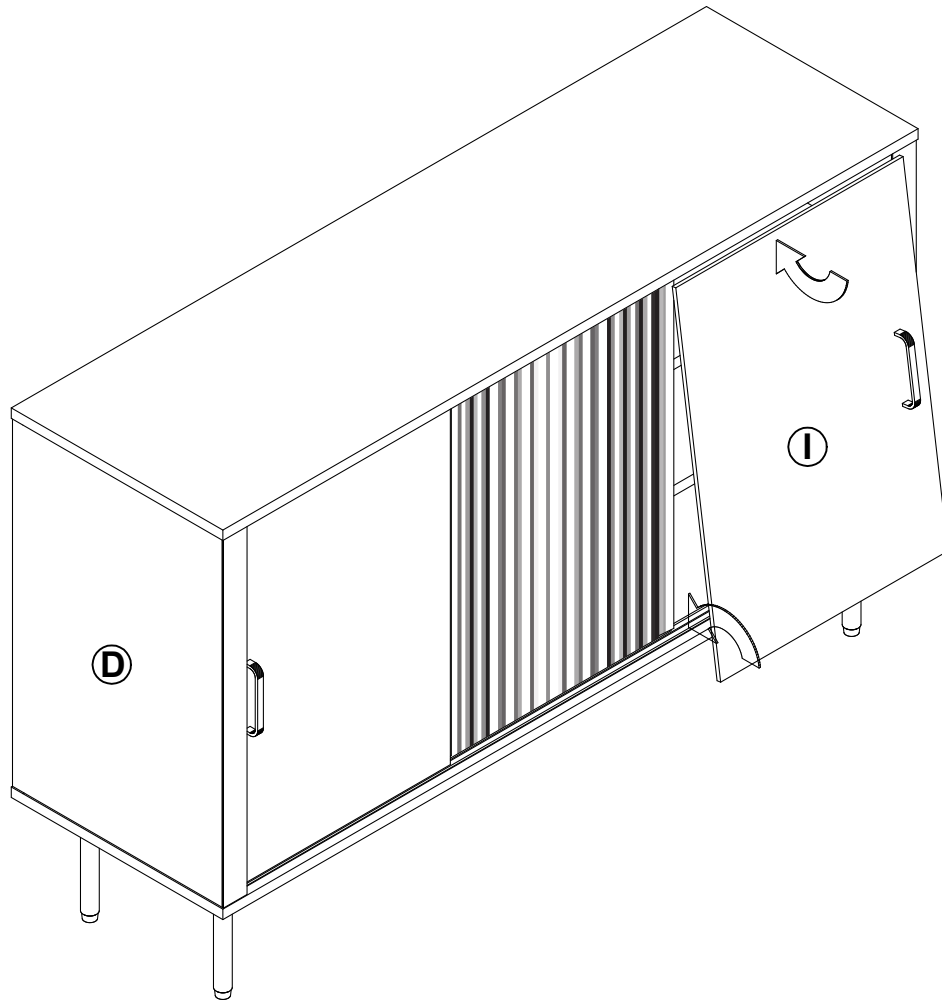

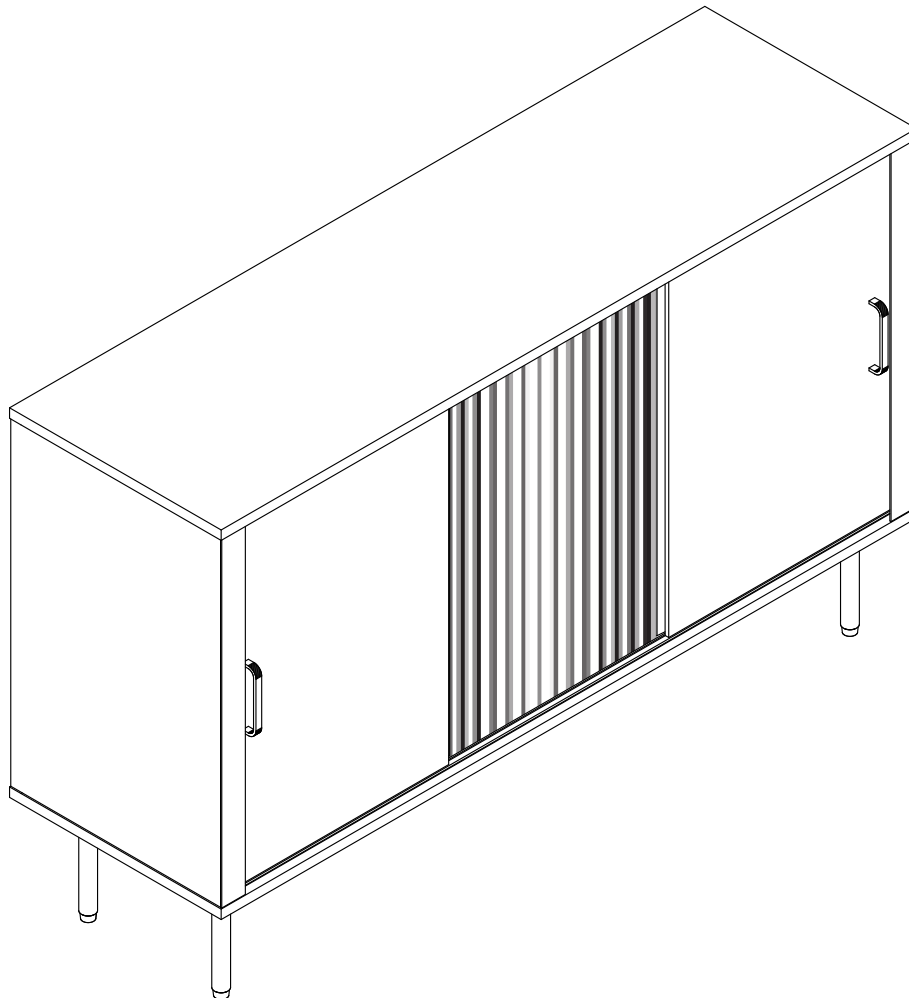

STEP 16

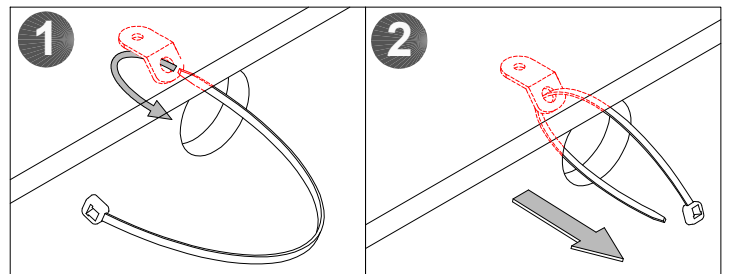
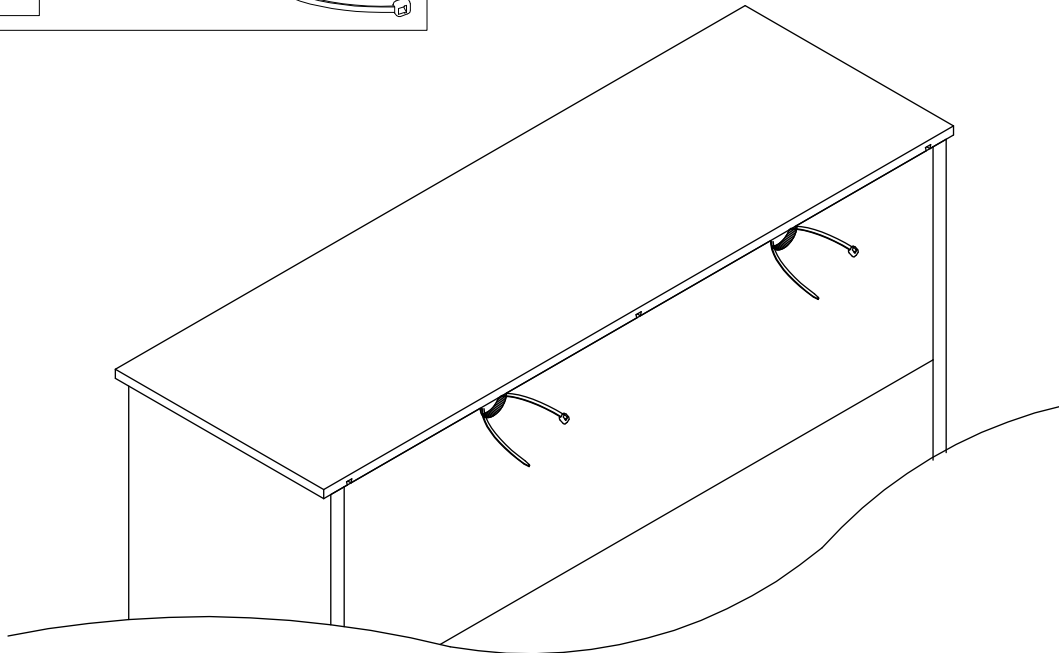
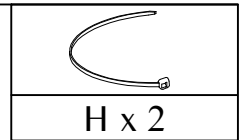
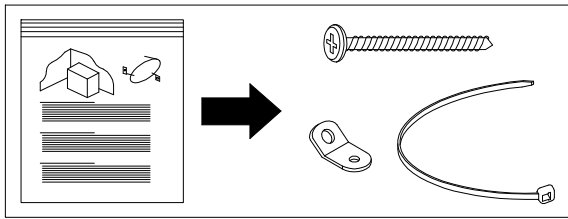
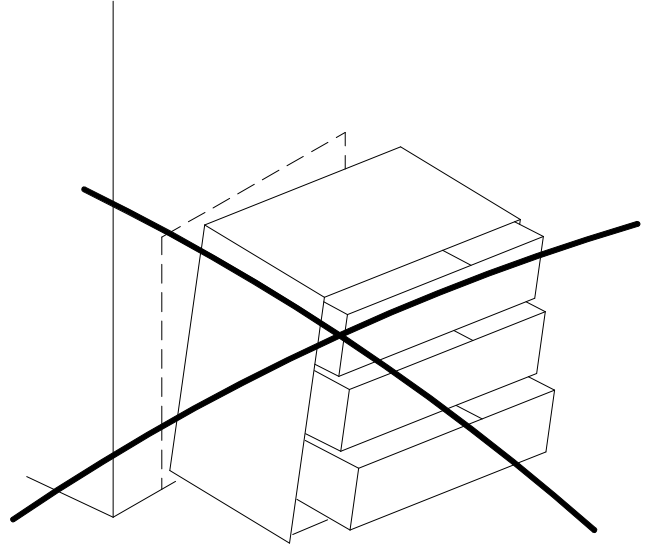
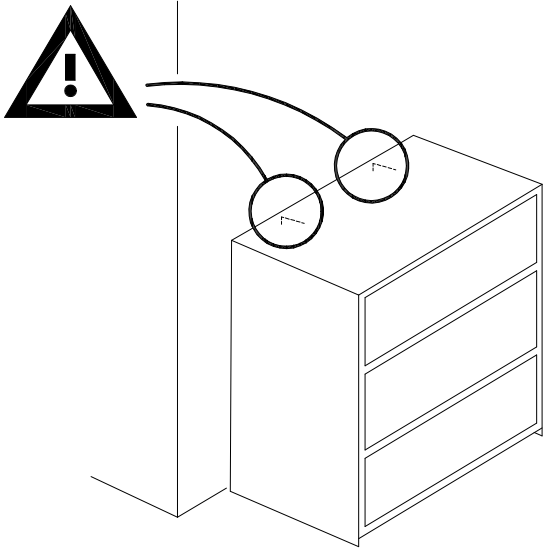

⚠ WARNING ⚠
AVERTISSEMENT / ADVERTENCIA



Move the furniture unit to its final position to the wall. Locate a stud in the wall behind the unit. Does not have to be centered.

	
G x 2	E x 2

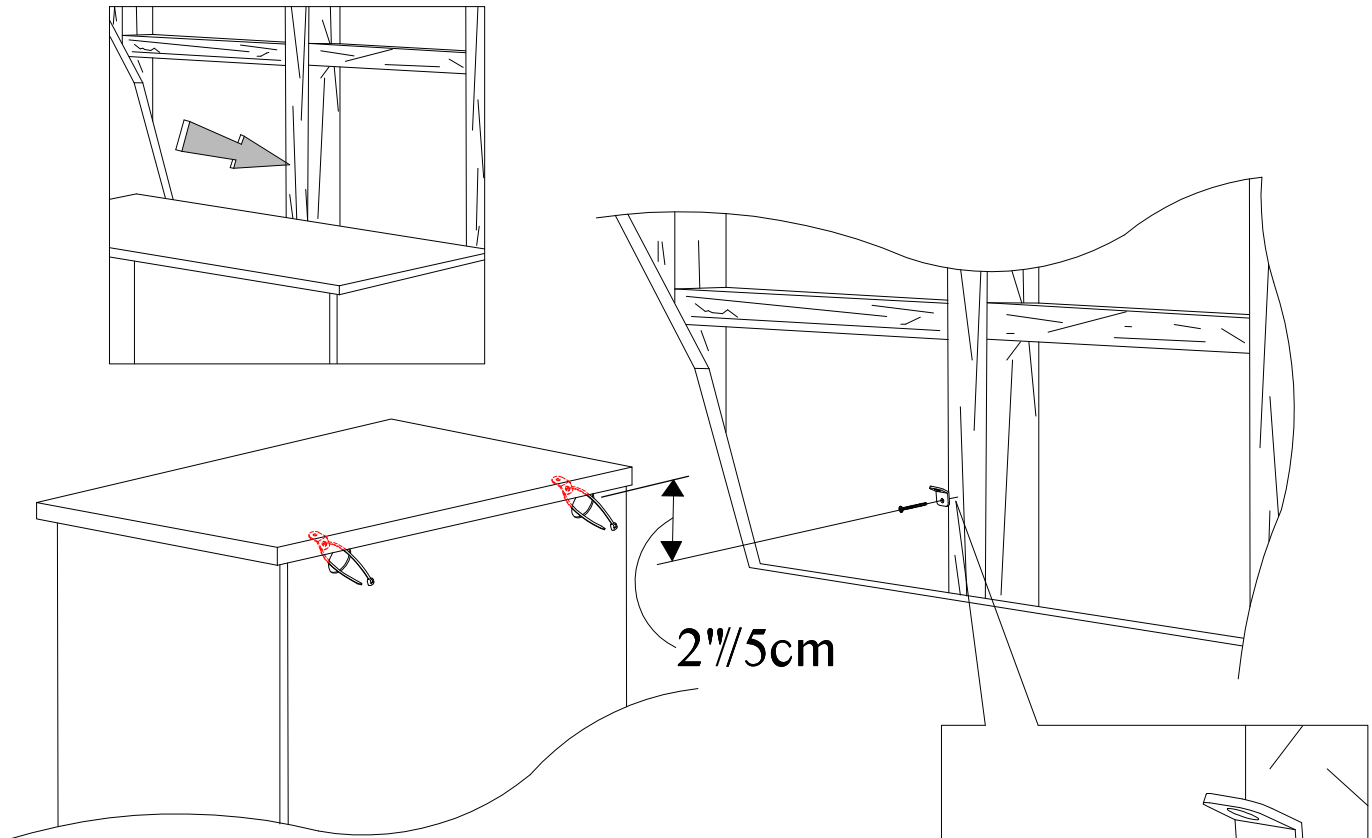

Locate the other bracket on the wall in the wall stud, 2 inches below the mounting bracket secured to the back of your unit. Attach to the wall stud using 2" screw through the smaller hole of bracket.

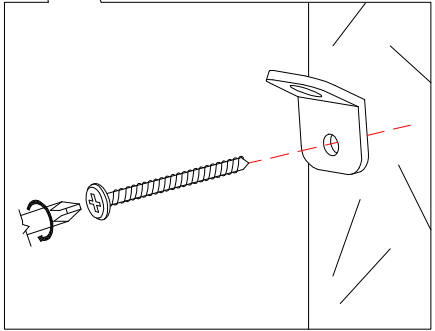

Place the furniture into position so both mounting brackets are vertically in line. Lace the end of the restraint strap through the larger hole in each mounting bracket. Confirm that the strap is securely laced and locked.

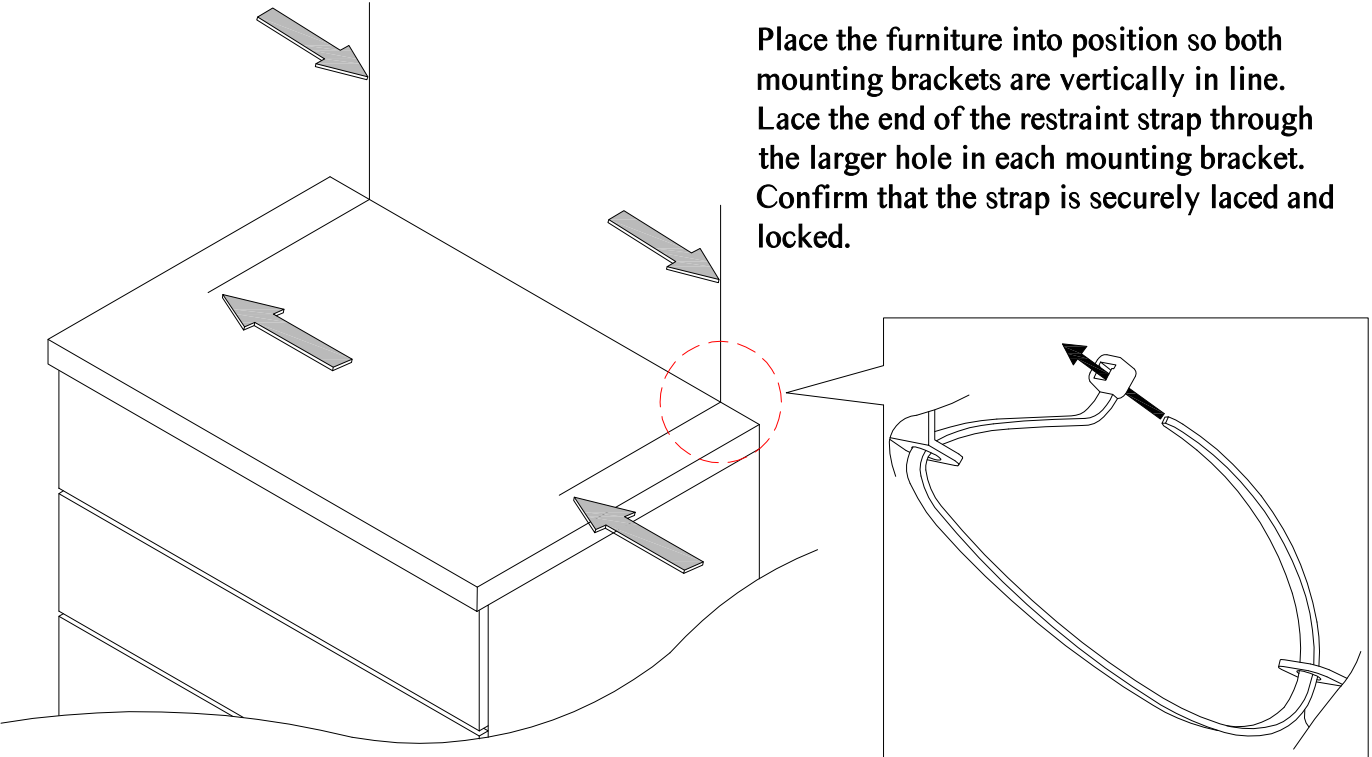

MAXIMUM LOADS CHARGES MAXIMALES / CARGA MAXIMA

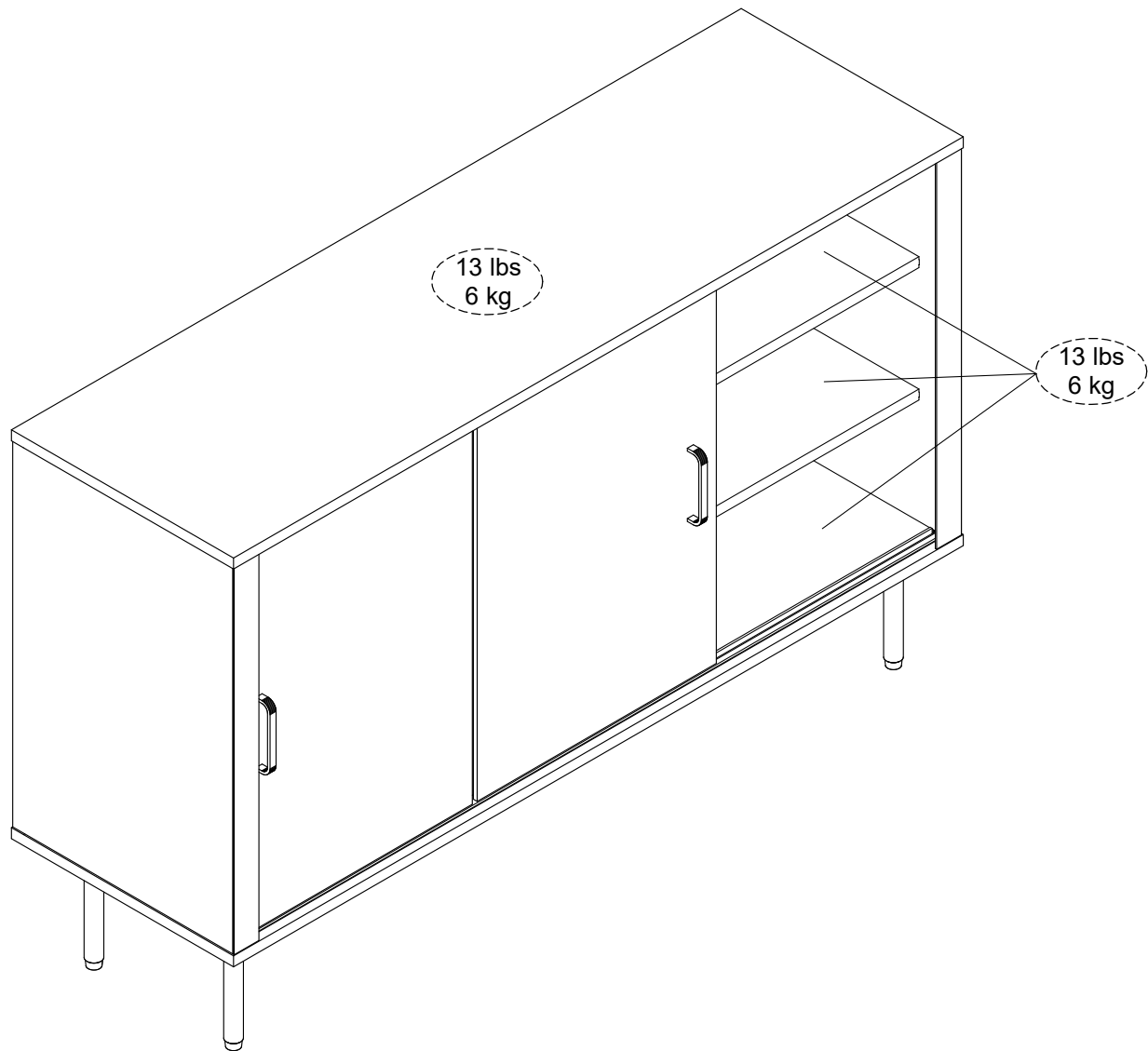

This unit has been designed to support the maximum loads shown. Exceeding these load limits could cause sagging, instability, product collapse, and/or serious injury.

Ce meuble a été conçu pour supporter les charges maximales indiquées. En excédant ces limites de charge, le meuble pourrait devenir instable, s'effondrer, et/ou causer des blessures graves.

Esta unidad ha sido diseñada para soportar la carga máxima anotada. El exceder estos límites puede causar inestabilidad, colapsarse y/o causar serias lesiones.