

TV Stand

WARNING

Serious or fatal injury may occur from unexpected assembly or use.

1. During the assembly process, keep all parts away from babies or children.
2. Always securely fix this product to the wall. Make sure the wall area to be drilled is free from hidden electrical wires, water and gas pipes.
3. Use of tip-over restraints may only reduce, but not eliminate the risk of tip-over.
4. Unless specially designed to accommodate, do not set heavy objects on top of this product.
5. Place the heaviest items on the lowest shelf.
6. Never allow children to climb or bang on drawers, doors or shelves.

WARNING



Children have died from furniture tipover. To reduce the risk of furniture tipover:

- **ALWAYS** install tipover restraint provided.
- **NEVER** allow children to stand, climb or hang on drawers, doors, or shelves.
- **NEVER** open more than one drawer at a time.
- **Place heaviest items in the lowest drawers.**

Parts List (EN) / Teile Liste (DE)

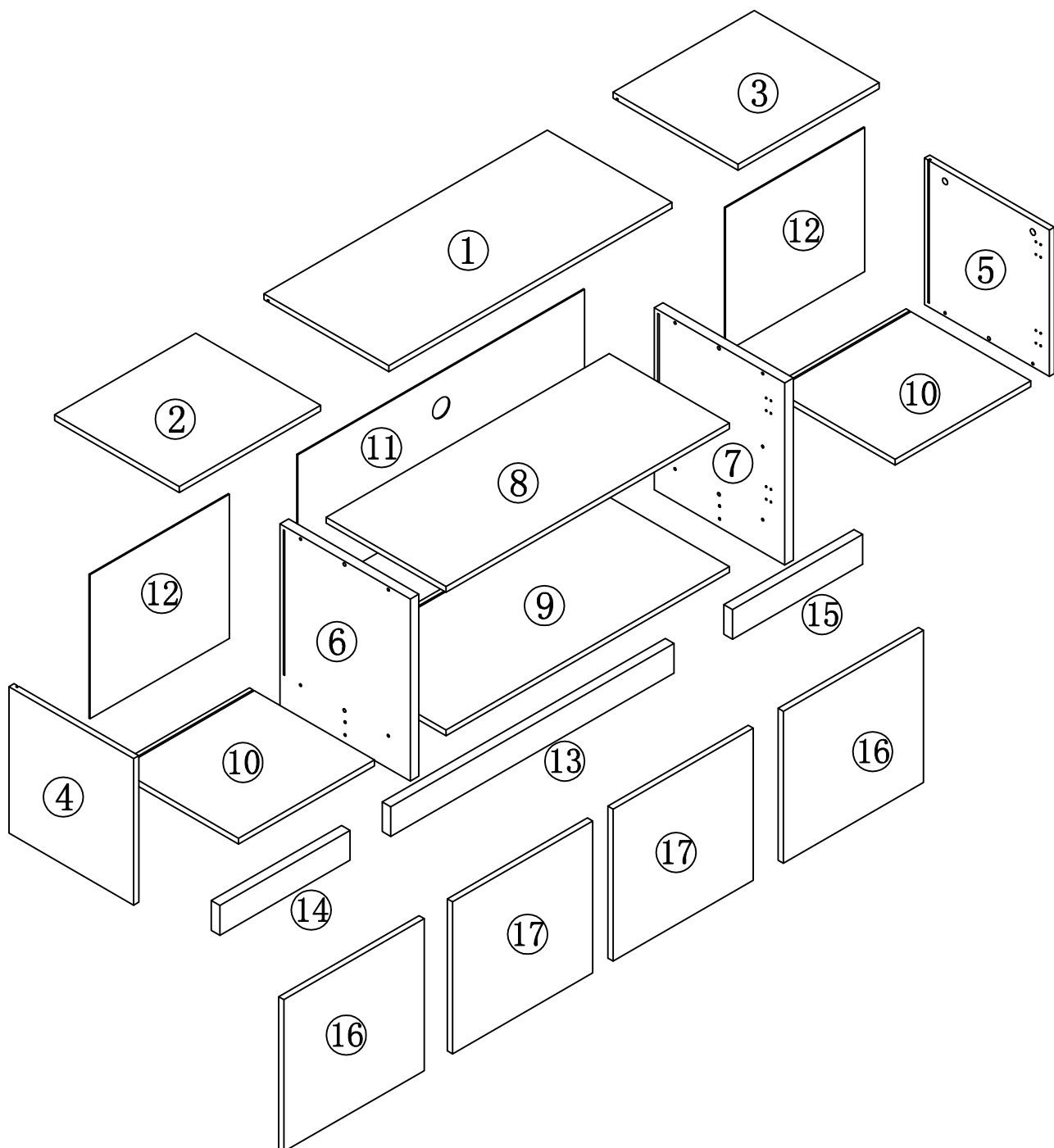

Parts List (EN) / Teile Liste (DE)

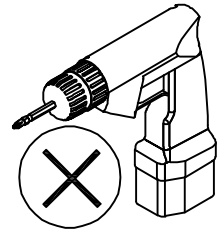
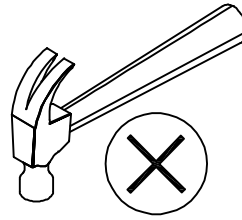
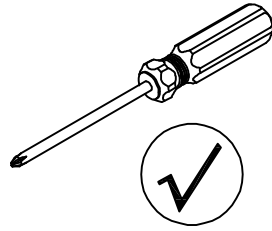
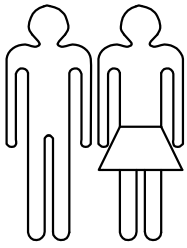

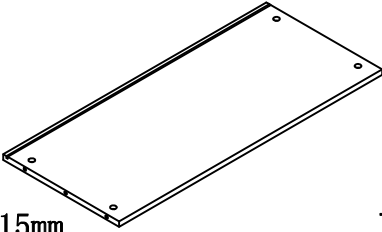
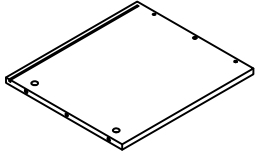
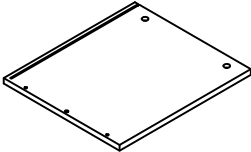
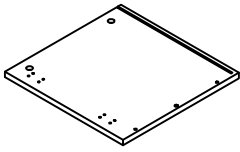
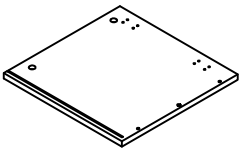
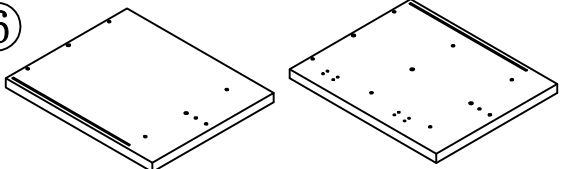
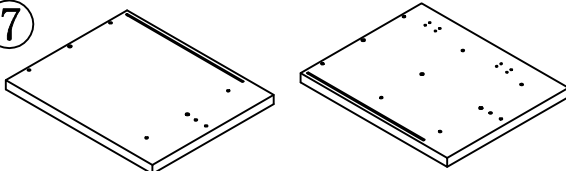
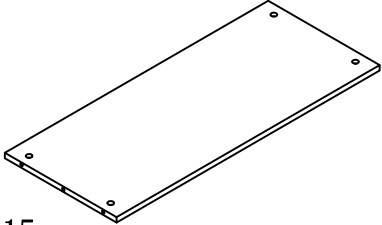
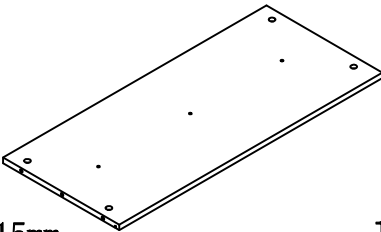
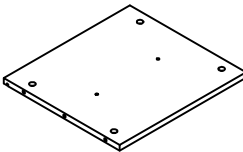
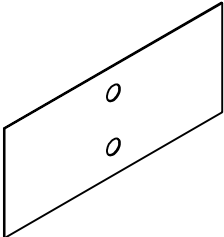
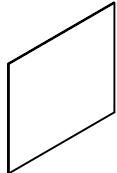
<p>①</p>  <p>826*364*15mm</p> <p>1PC</p>	<p>②</p>  <p>412*364*15mm</p> <p>1PC</p>
<p>③</p>  <p>412*364*15mm</p> <p>1PC</p>	<p>④</p>  <p>370*364*15mm</p> <p>1PC</p>
<p>⑤</p>  <p>370*364*15mm</p> <p>1PC</p>	<p>⑥</p>  <p>one side the other side</p> <p>460*380*25mm</p> <p>1PC</p>
<p>⑦</p>  <p>one side the other side</p> <p>460*380*25mm</p> <p>1PC</p>	<p>⑧</p>  <p>826*346*15mm</p> <p>1PC</p>
<p>⑨</p>  <p>826*364*15mm</p> <p>1PC</p>	<p>⑩</p>  <p>396*364*15mm</p> <p>2PCS</p>
<p>⑪</p>  <p>836*364*3mm</p> <p>1PC</p>	<p>⑫</p>  <p>406*364*3mm</p> <p>2PCS</p>



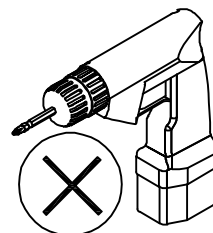
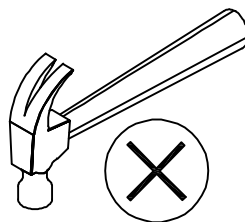
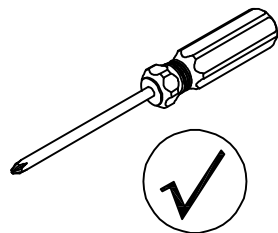
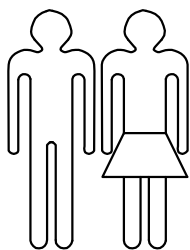

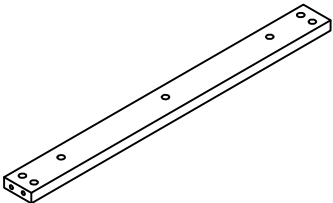
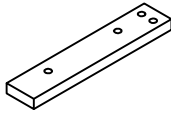
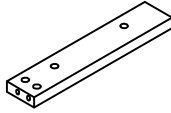
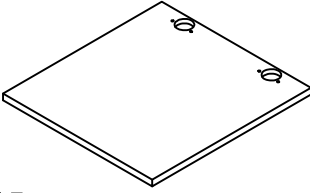
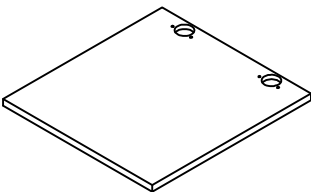

Parts List (EN) / Teile Liste (DE)

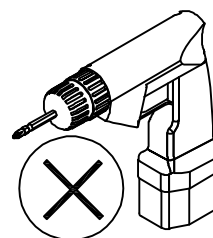
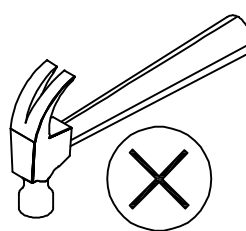
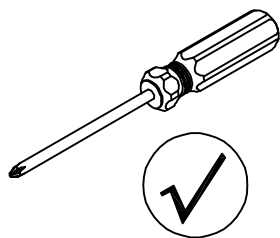
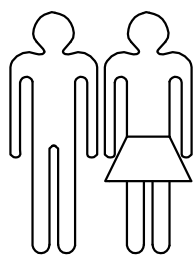

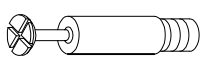
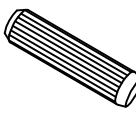
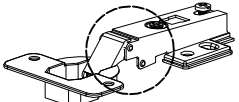
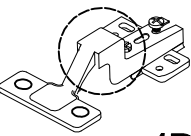
<p>⑬</p>  <p>826*75*25mm</p> <p>1PC</p>	<p>⑭</p>  <p>380*75*25mm</p> <p>1PC</p>
<p>⑮</p>  <p>380*75*25mm</p> <p>1PC</p>	<p>⑯</p>  <p>409*384*15mm</p> <p>2PCS</p>
<p>⑰</p>  <p>409*384*15mm</p> <p>2PCS</p>	

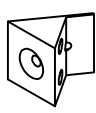
Hardware List (EN) / Teile Liste (DE)

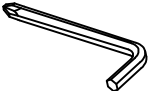

A  Ø15*9mm 43PCS	B  Ø6*35mm 43PCS	C  Ø8*30mm 14PCS	D Full overlay  Ø35 4PCS
E Insert  Ø35 4PCS	F  Ø3*15mm 64PCS	G  14*13*9mm 16PCS	H  Ø20mm 43PCS
I  M4 1PC	J  Ø10*9mm 8PCS		

Assembly (EN) / Montageschritte (DE)

CAM BOLT INSTALLATION AS BELOW:

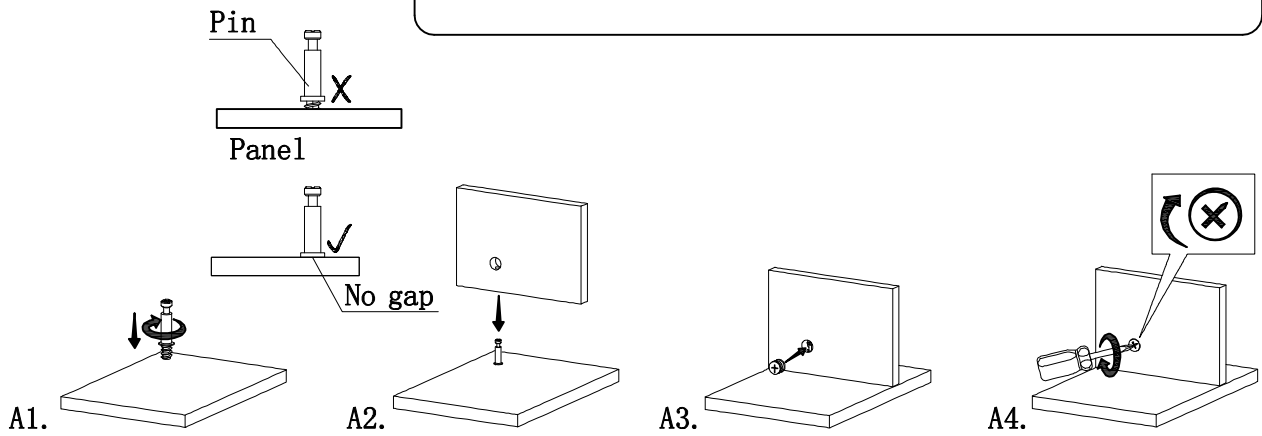
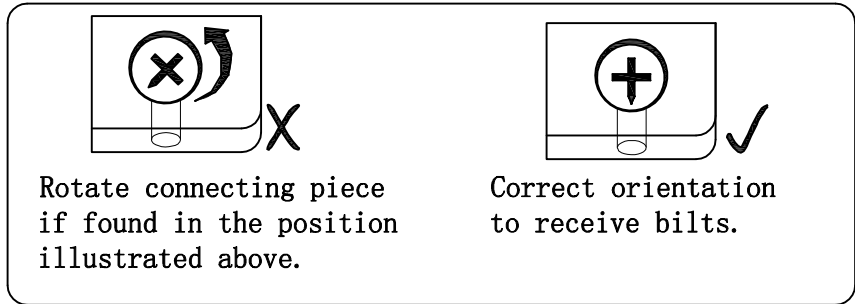
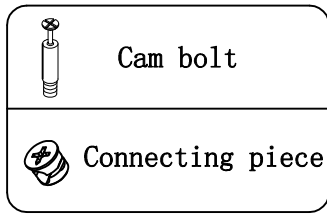

STEP 1

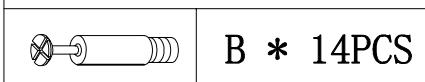
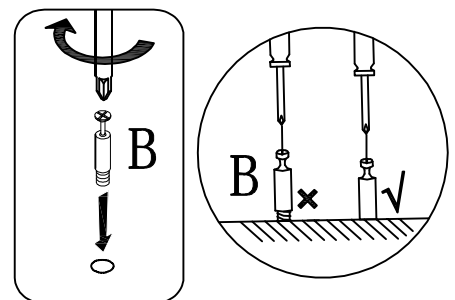
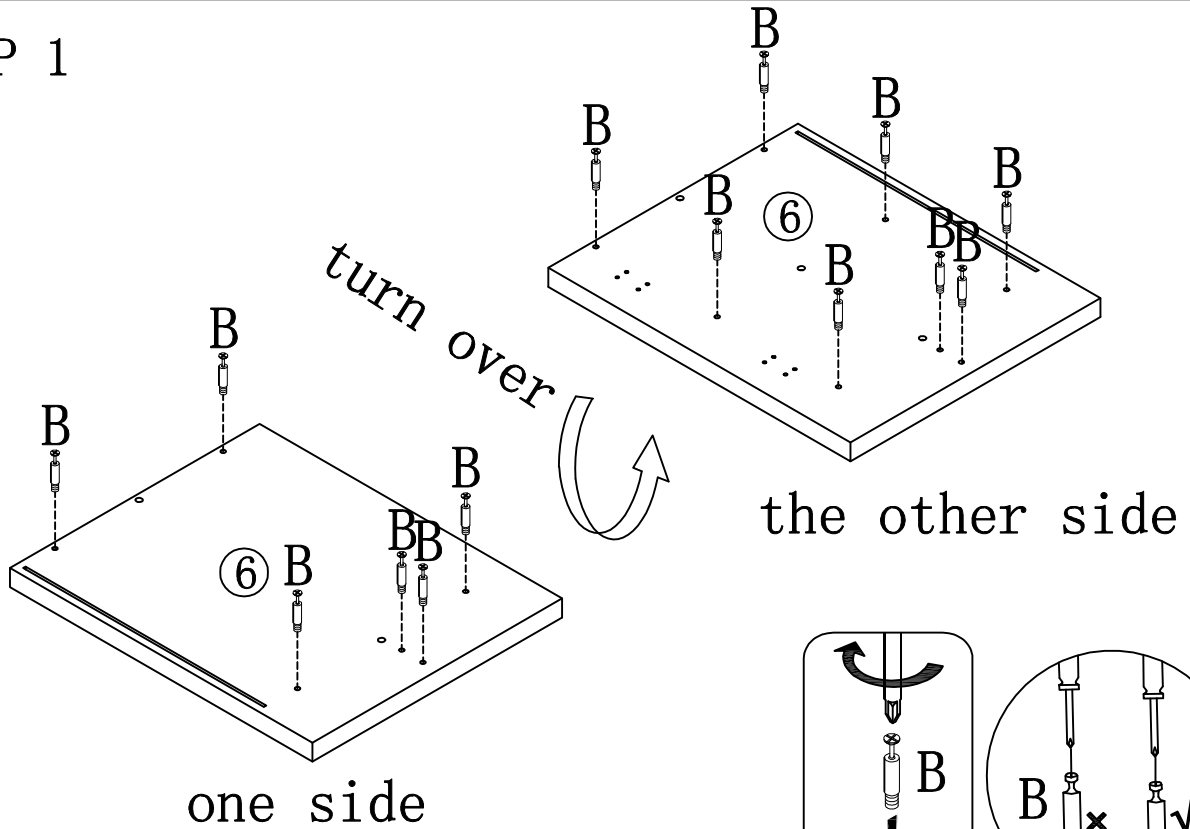

Assembly (EN) /Montageschritte (DE)

STEP 2

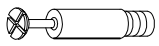
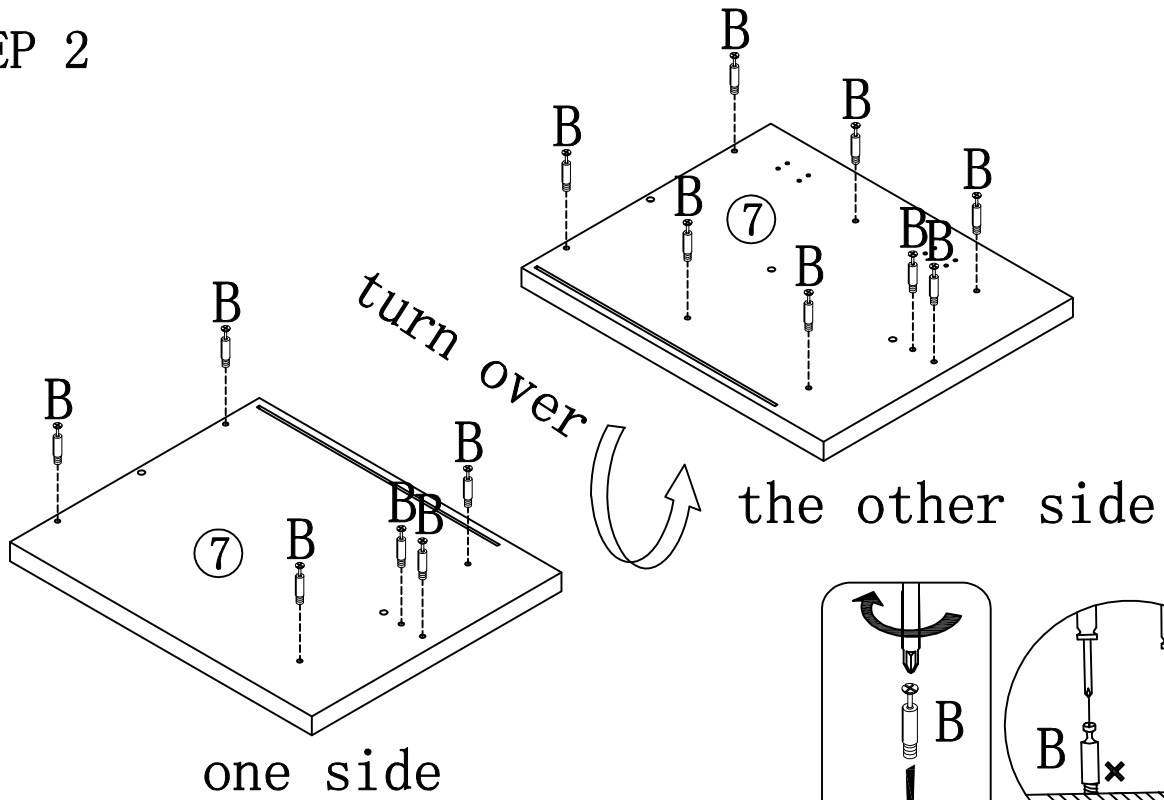

B * 14PCS

STEP 3

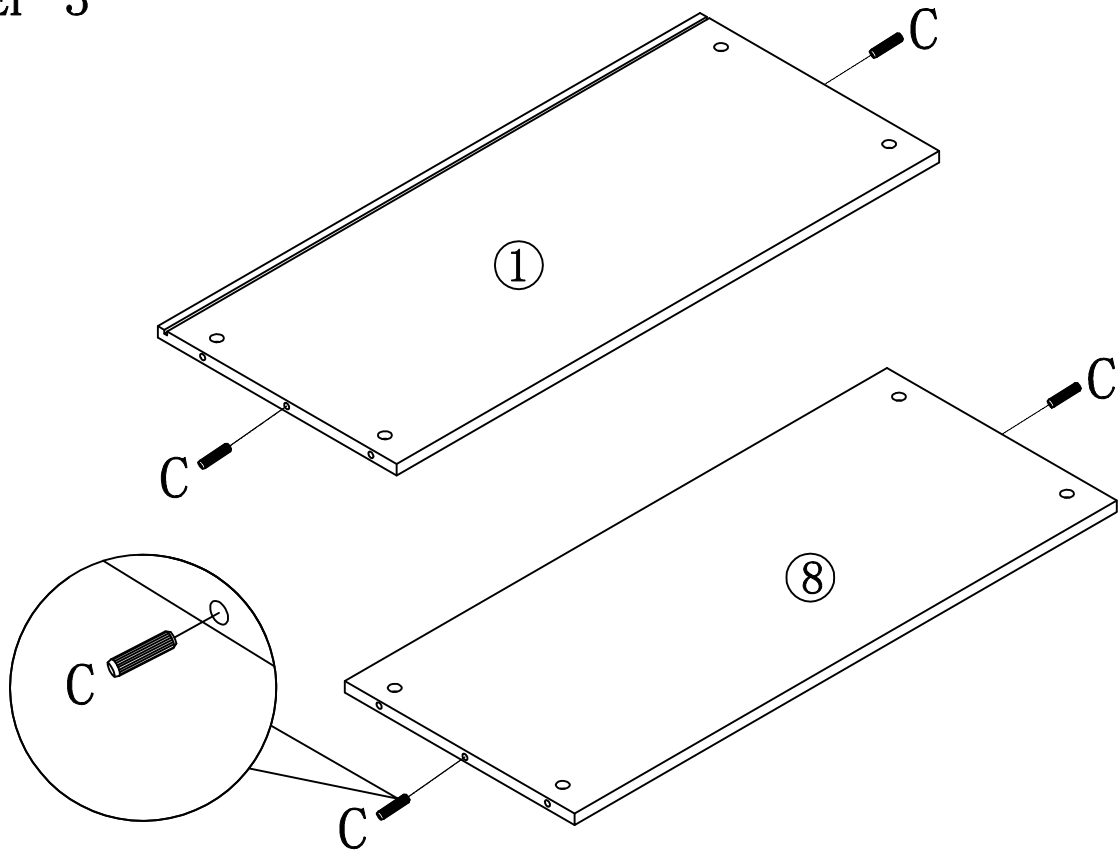



C * 4PCS

Assembly (EN) /Montageschritte (DE)

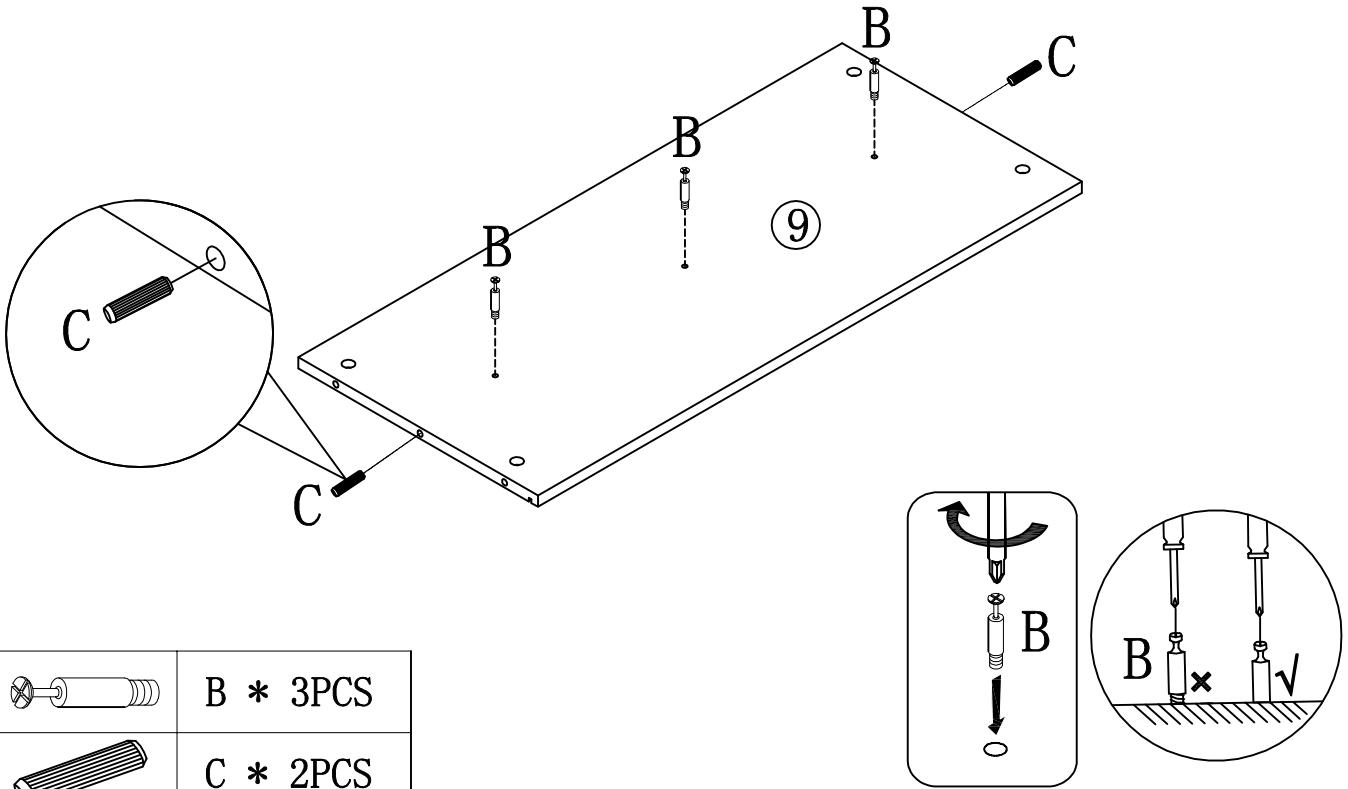
STEP 4

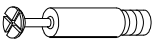

	B * 3PCS
	C * 2PCS

STEP 5

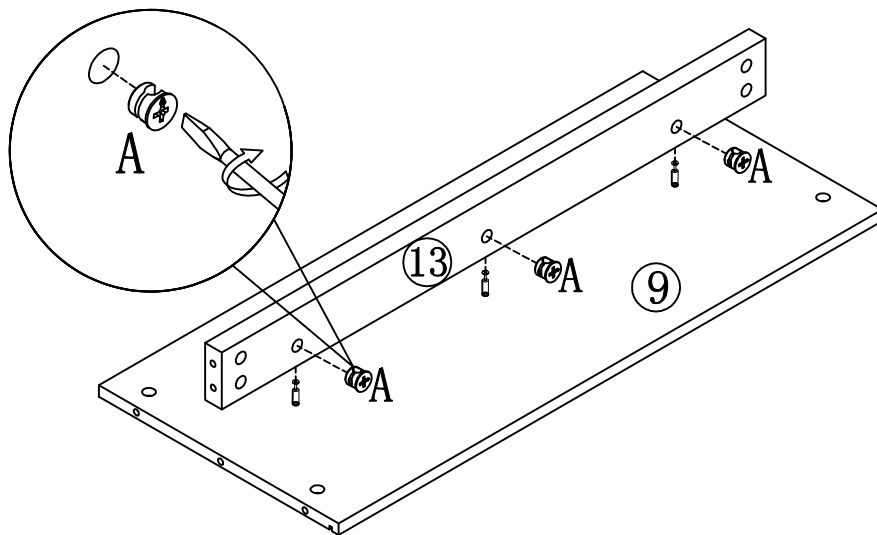

	A * 3PCS
---	----------

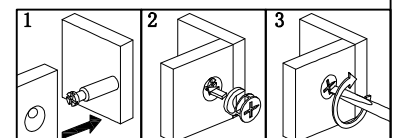

Assembly (EN) /Montageschritte (DE)

STEP 6

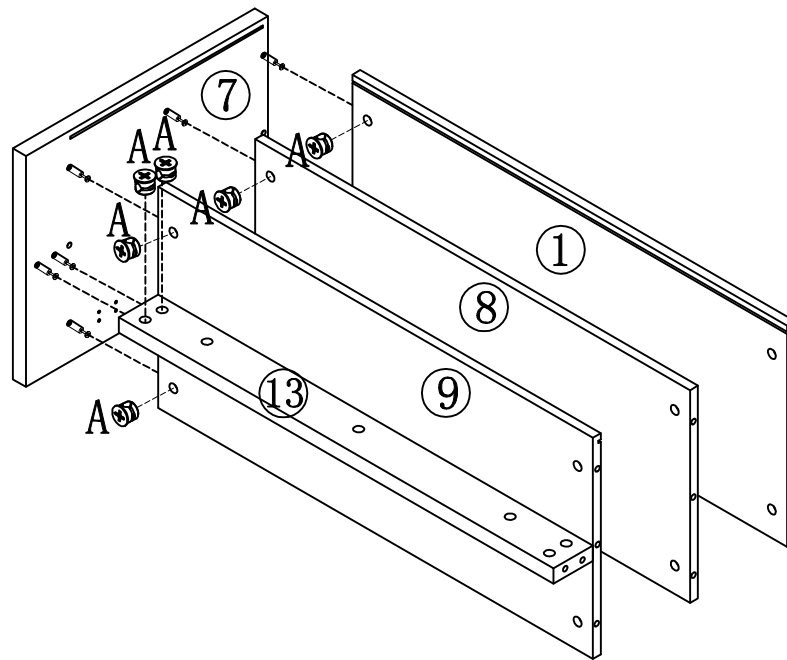

A * 8PCS

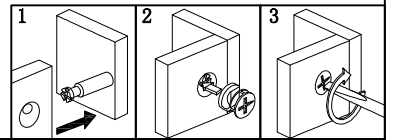

STEP 7

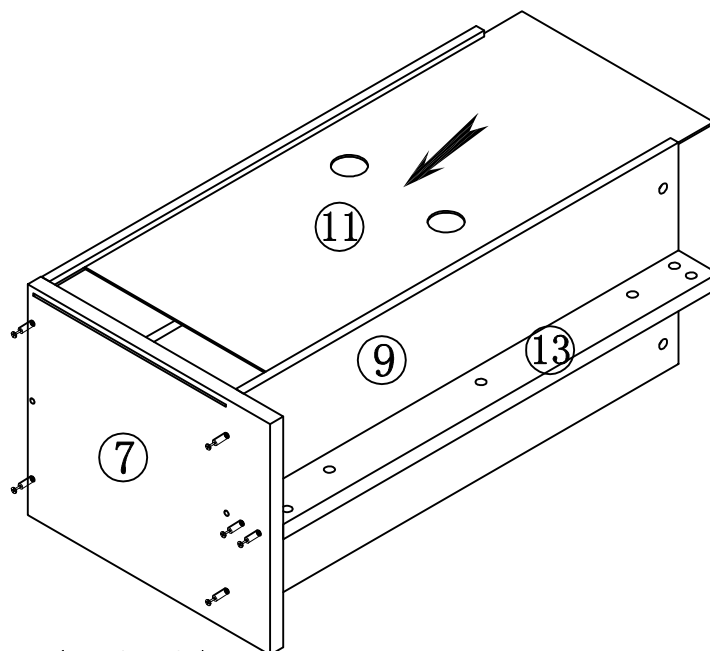
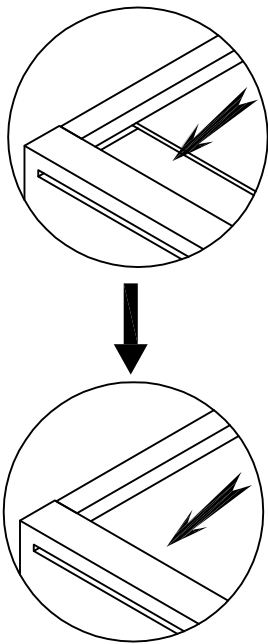

Thin back board needs to be inside the slot, otherwise blocks the opposite plate montage.

Assembly (EN) / Montageschritte (DE)

STEP 8

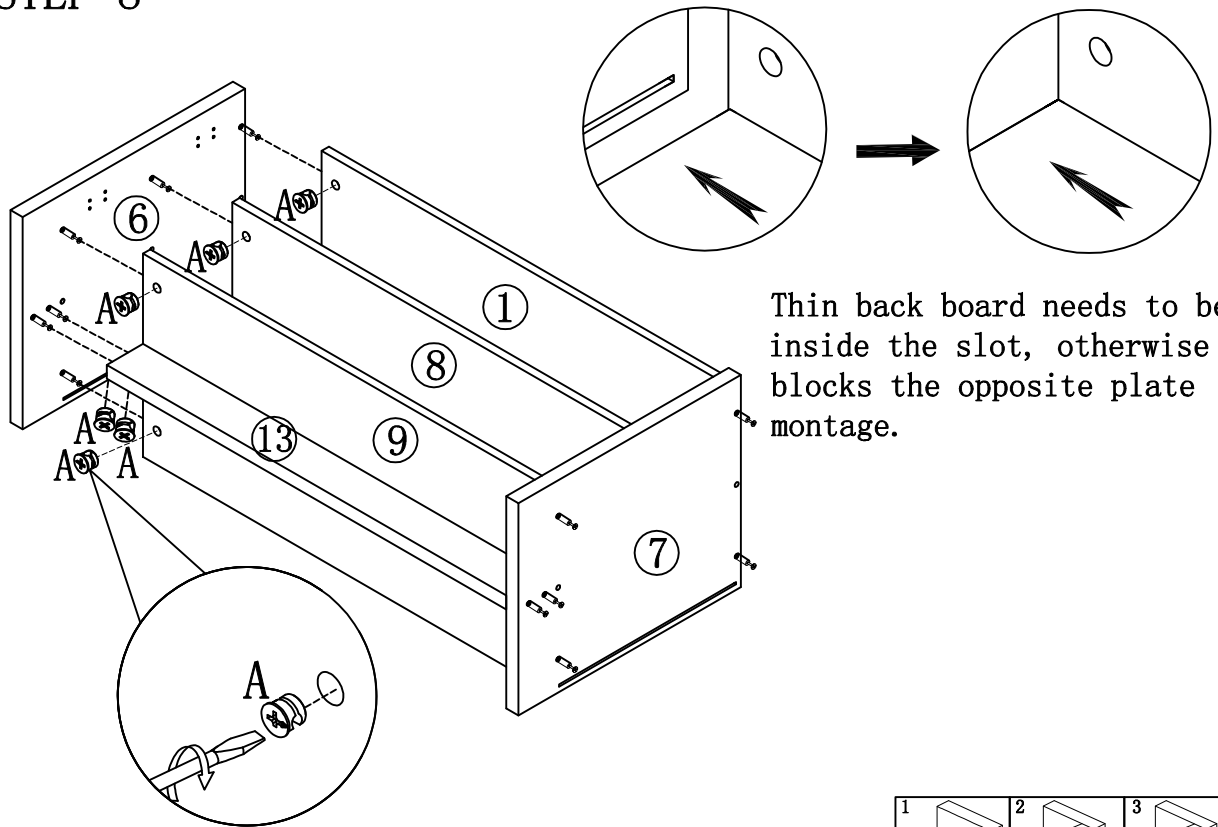

A * 8PCS

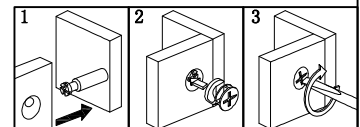

STEP 9

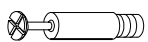
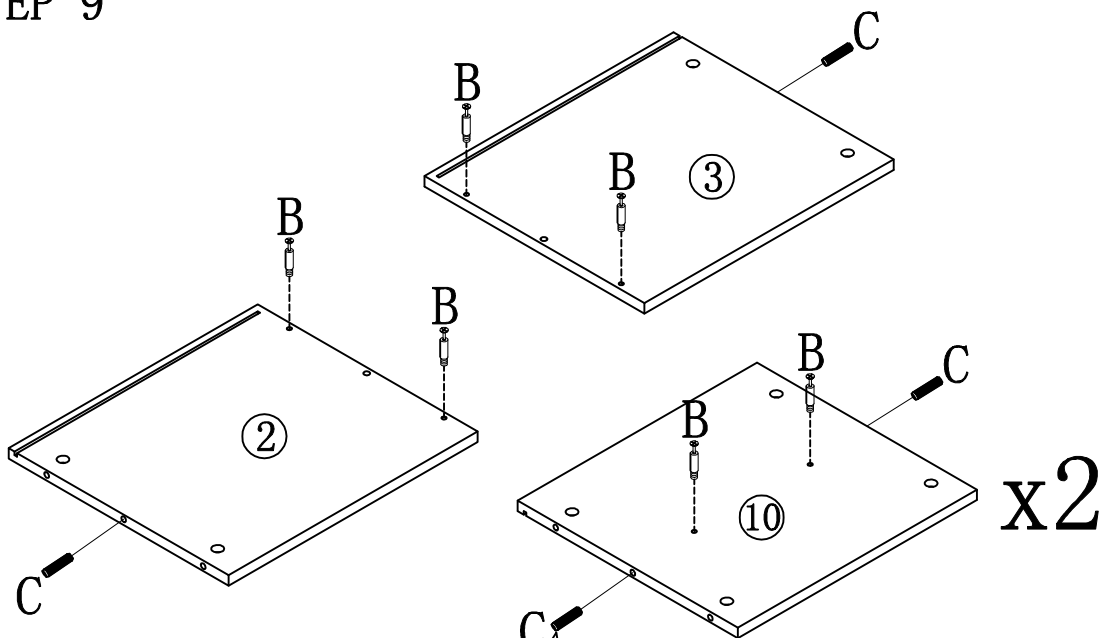

B * 8PCS



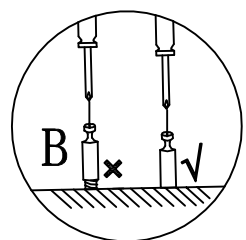
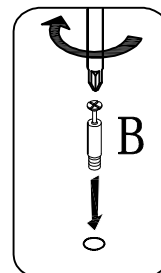
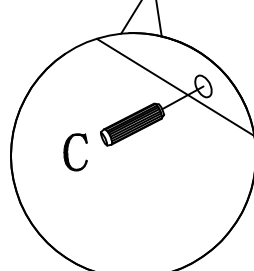

C * 6PCS

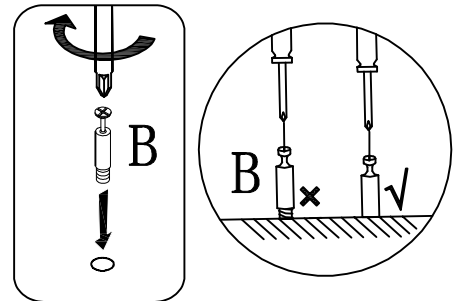
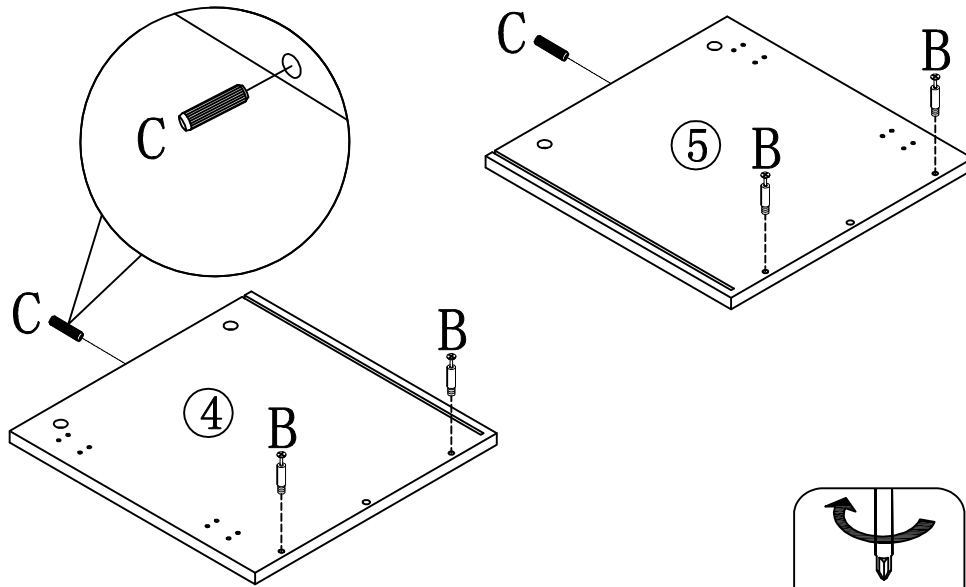

Assembly (EN) / Montageschritte (DE)

STEP 10

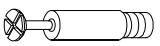

	B * 4PCS
	C * 2PCS

STEP 11

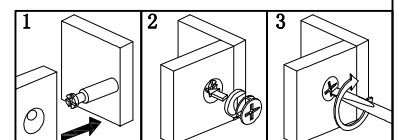
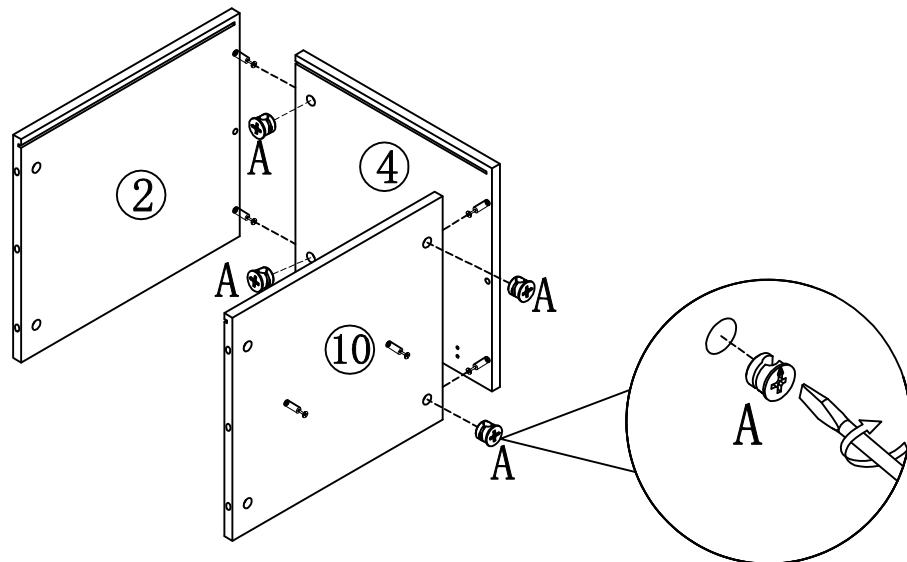

	A * 4PCS
---	----------

Assembly (EN) /Montageschritte (DE)

STEP 12

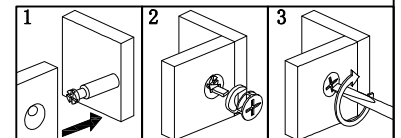
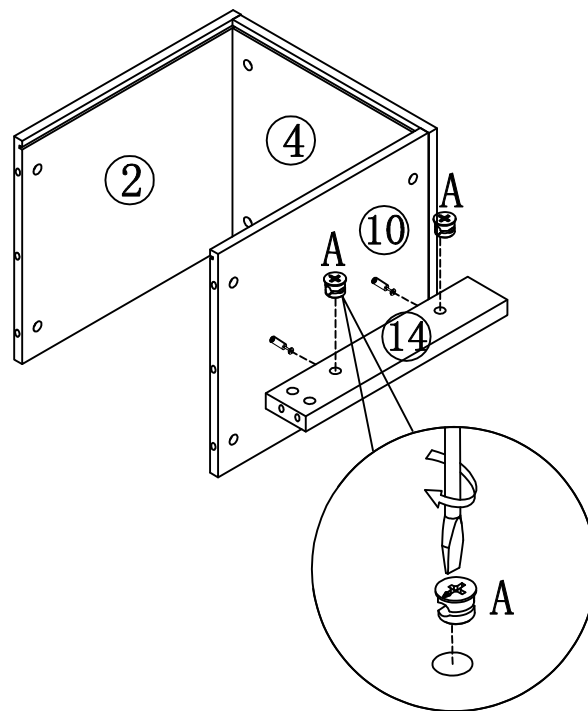

A * 2PCS

STEP 13

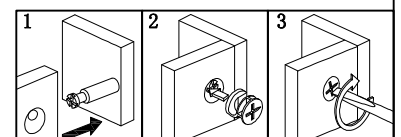
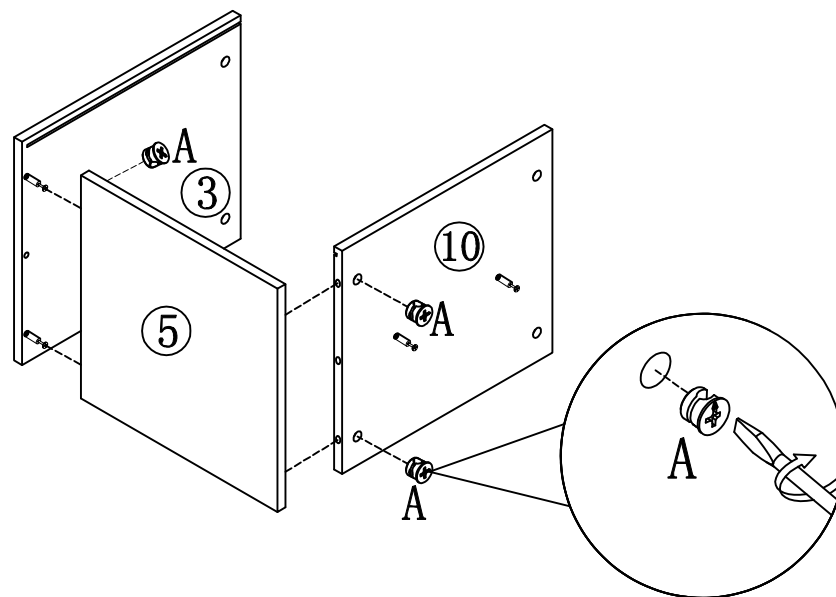

A * 4PCS

Assembly (EN) /Montageschritte (DE)

STEP 14

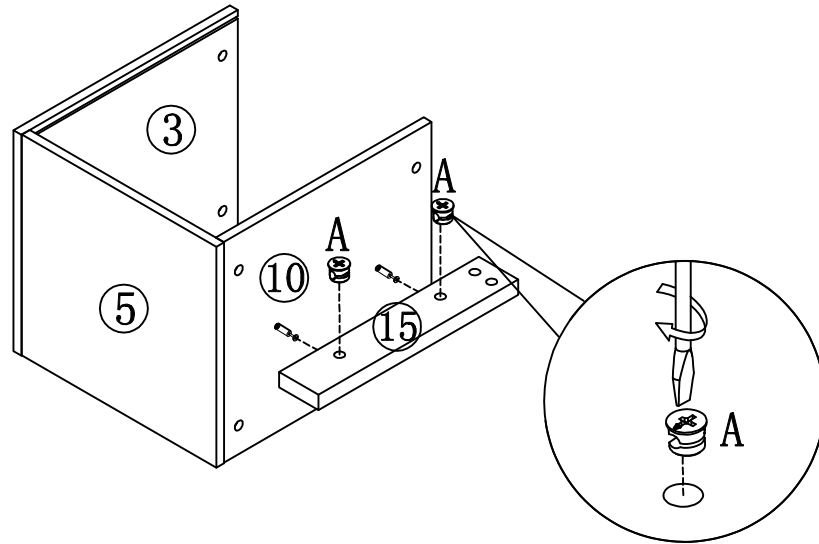

A * 2PCS

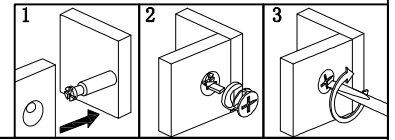

STEP 15

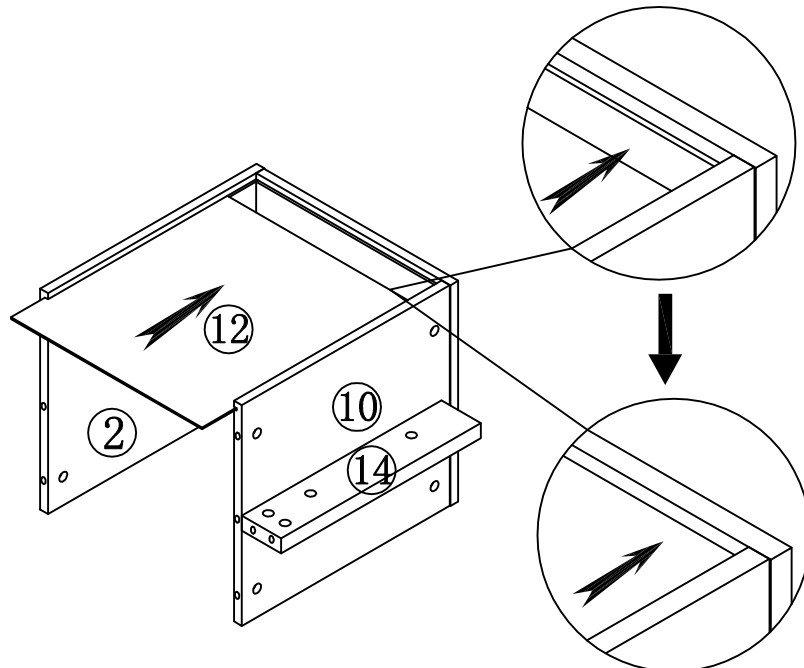

Thin back board needs to be inside the slot, otherwise blocks the opposite plate montage.

Assembly (EN) /Montageschritte (DE)

STEP 16

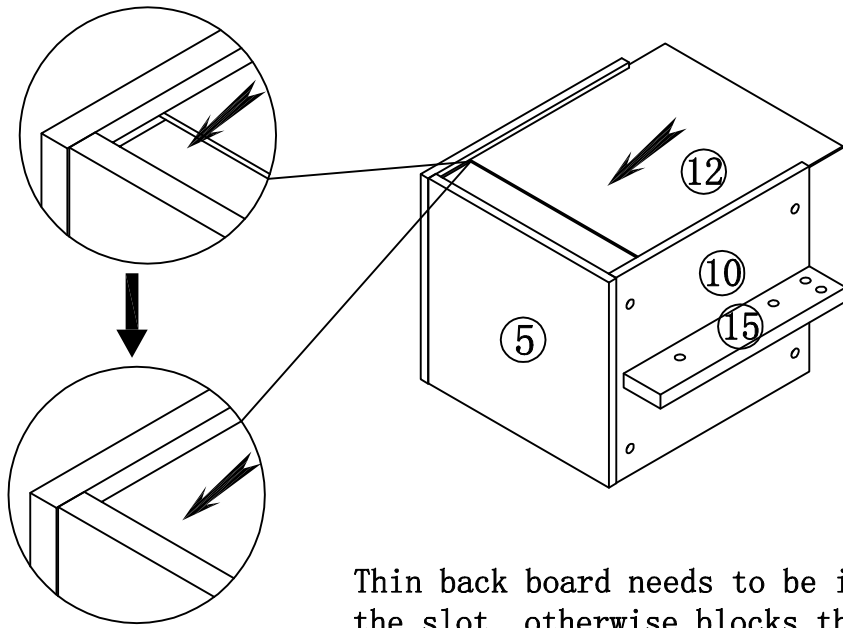

Thin back board needs to be inside the slot, otherwise blocks the opposite plate montage.

STEP 17

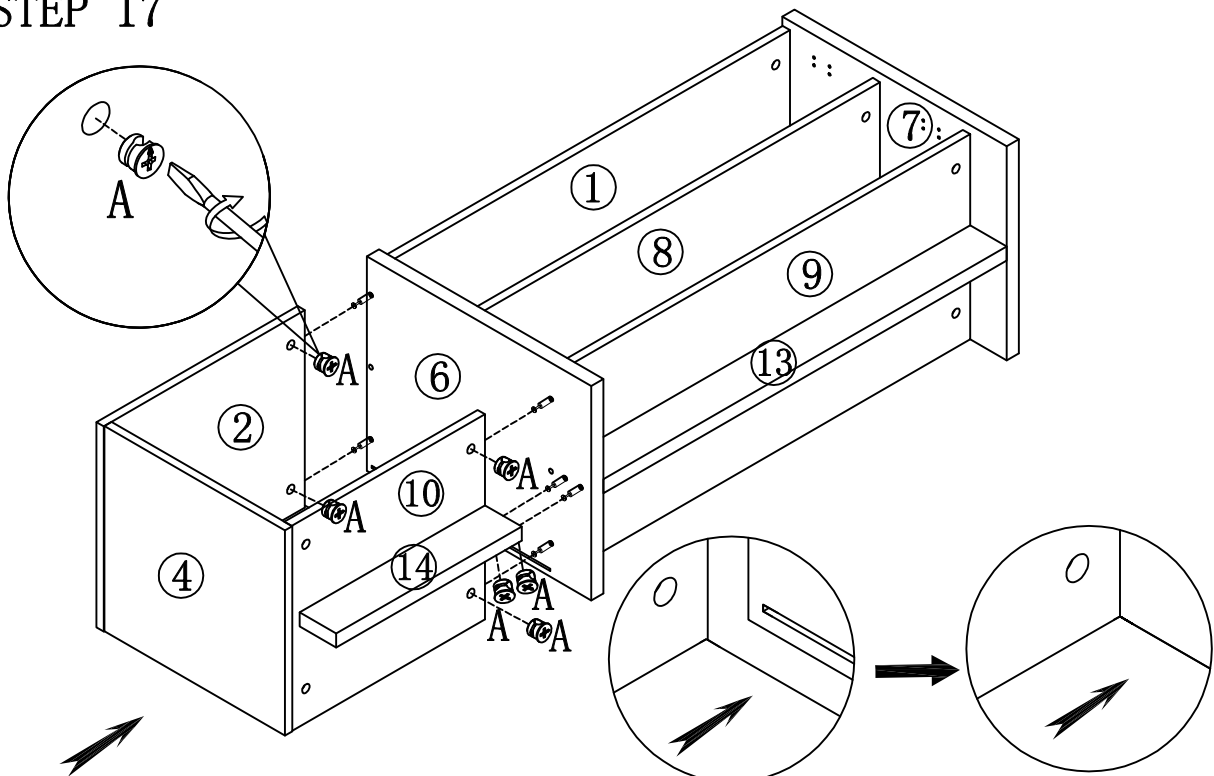

Thin back board needs to be inside the slot, otherwise blocks the opposite plate montage.



A * 6PCS

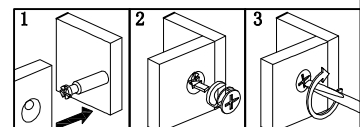

STEP 18

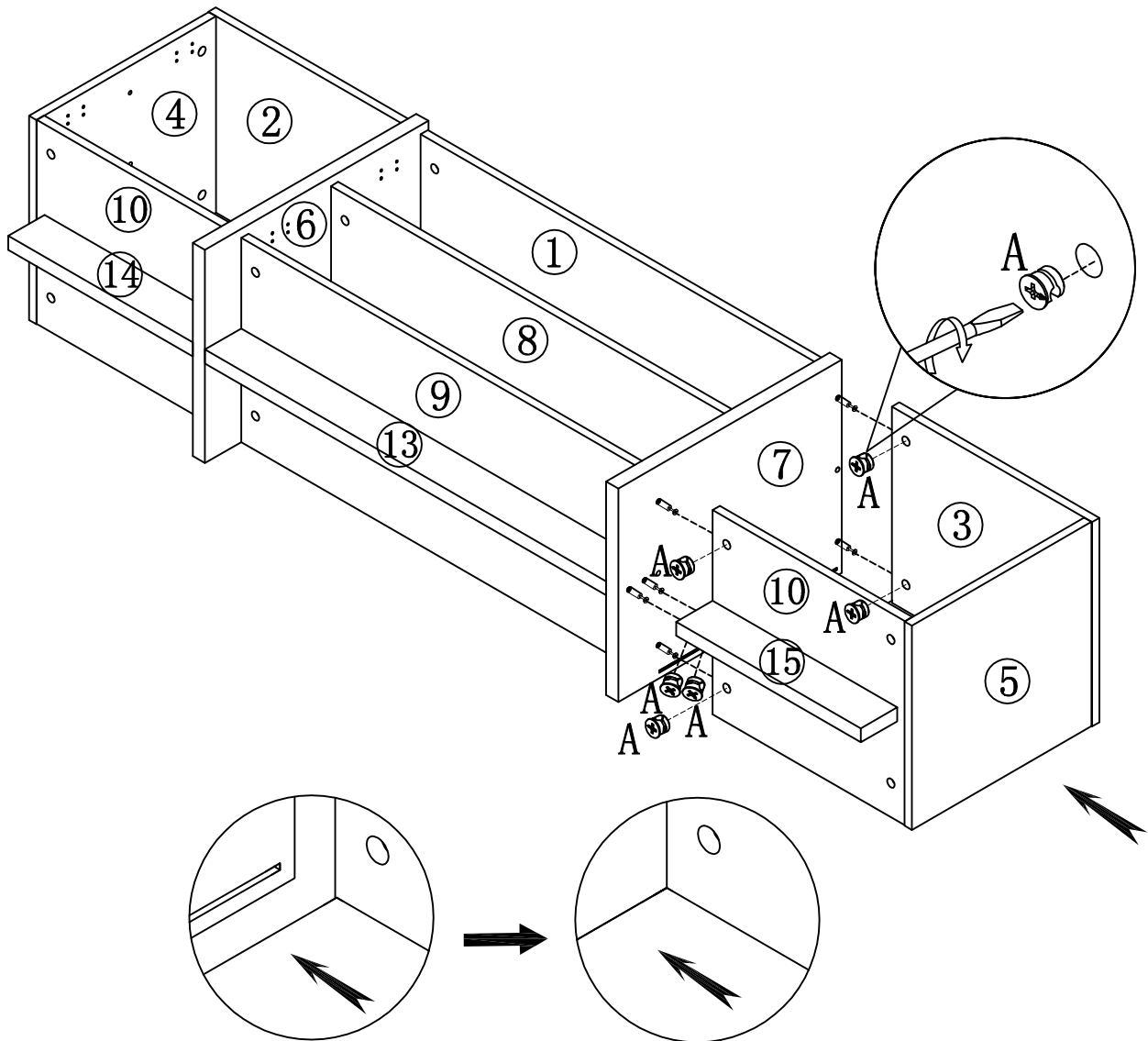

Thin back board needs to be inside the slot, otherwise blocks the opposite plate montage.



A * 6PCS

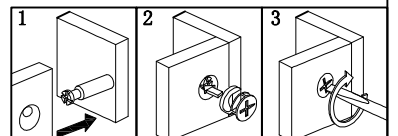

STEP 19

Full overlay

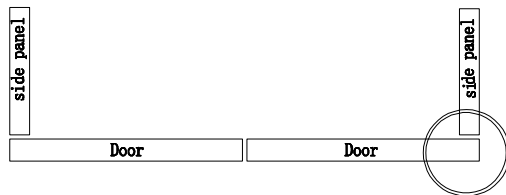
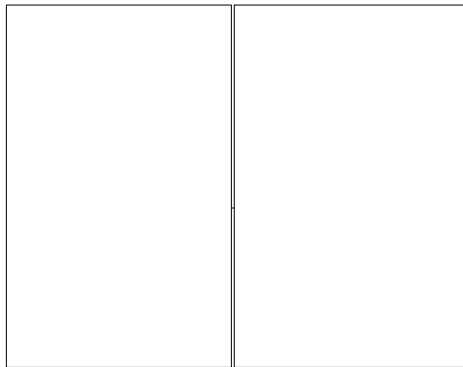

Door fully covers the panel

D

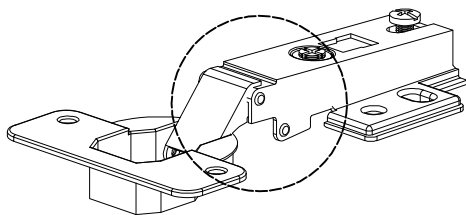

Full overlay
(For L/R Door #16)

Insert

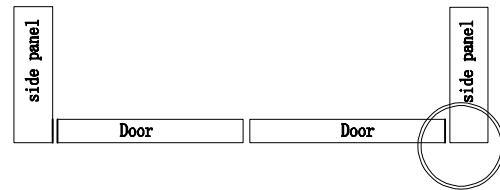
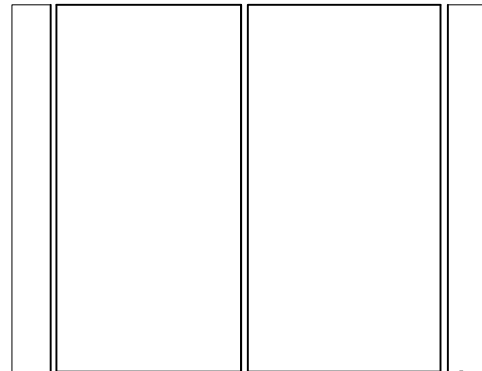

Doors was into the panel

E

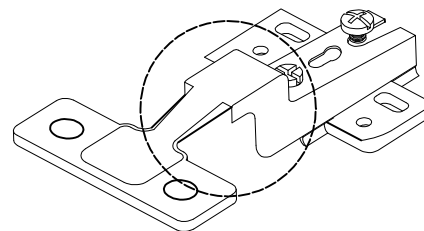

Insert
(For Middle Door #17)

Assembly (EN) /Montageschritte (DE)

STEP 20

D hinge ONLY for
L/R Door #16.

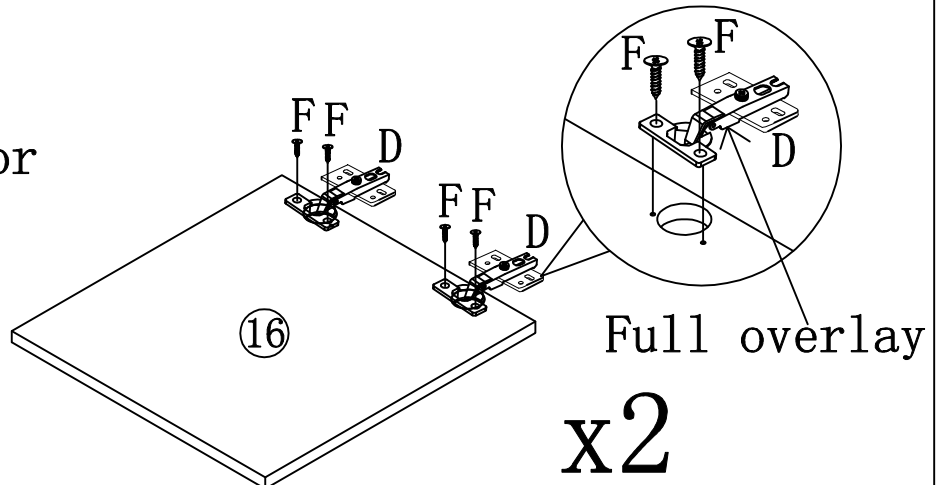

D * 4PCS



F * 8PCS

STEP 21

D hinge ONLY for
L/R Door #16.

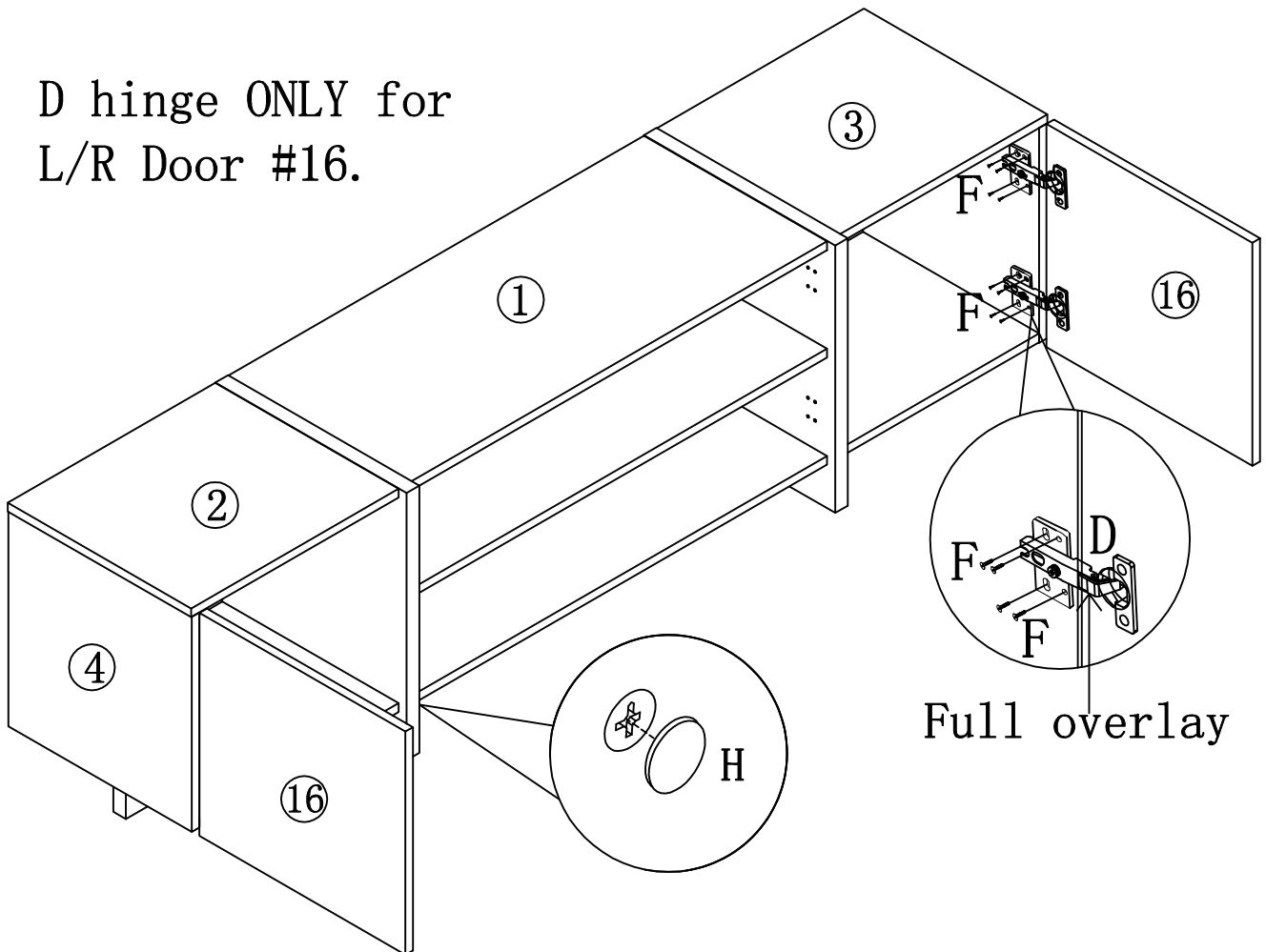

F * 16PCS





H * 43PCS

STEP 22

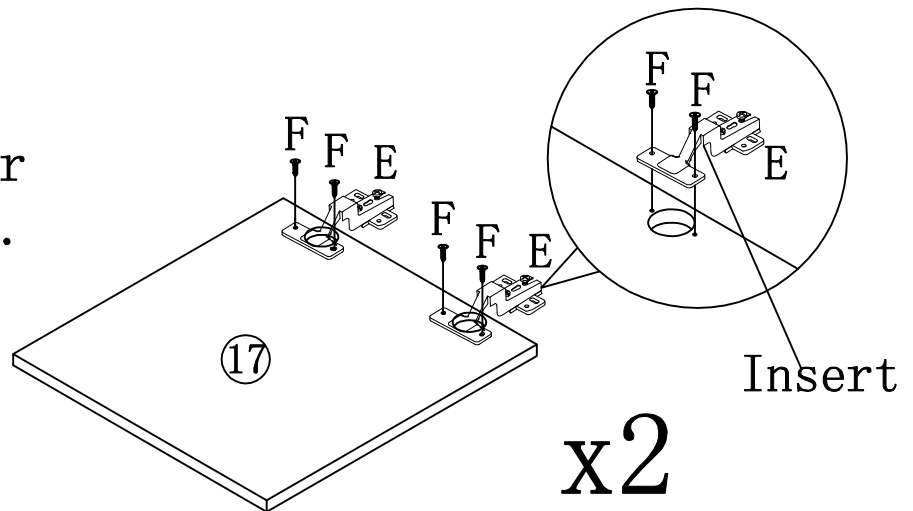
E hinge ONLY for
Middle Door #17.

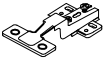

	E * 4PCS
	F * 8PCS

STEP 23

E hinge ONLY for
Middle Door #17.

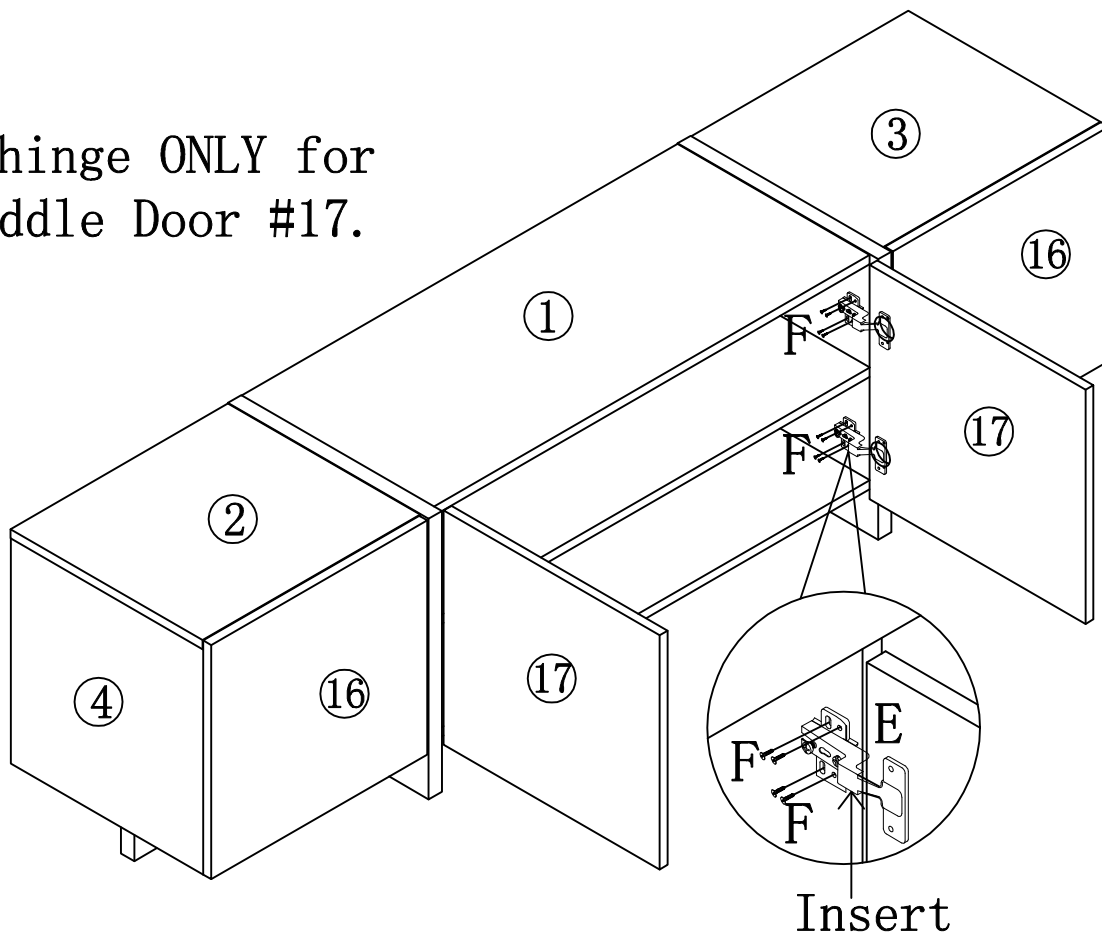

	F * 16PCS
---	-----------

Assembly (EN) /Montageschritte (DE)

STEP 24



NOTE : If you notice that the cabinet doors are not properly aligned, such as significant gaps or vertical or horizontal misalignment, please adhere to the following adjustment instructions.

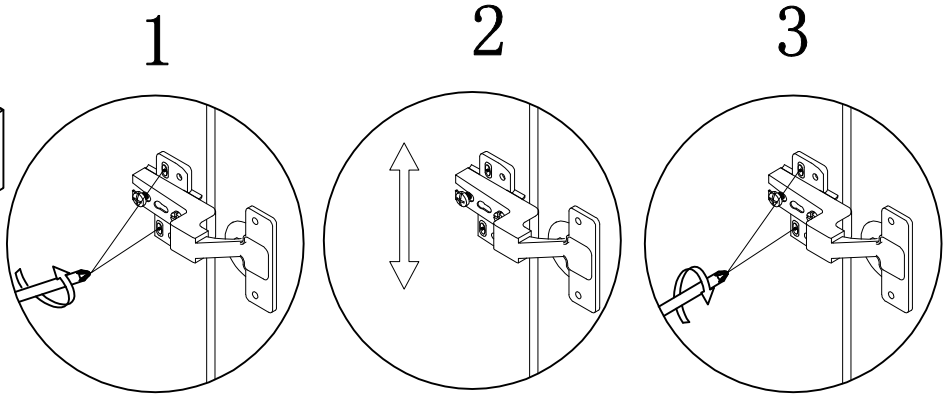
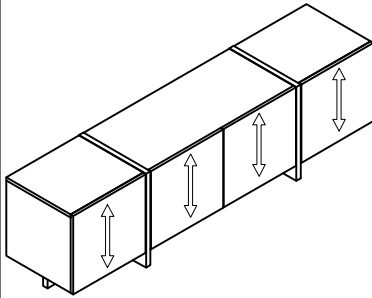

lose these 2 screws move hinge up/down tighten these 2 screws again

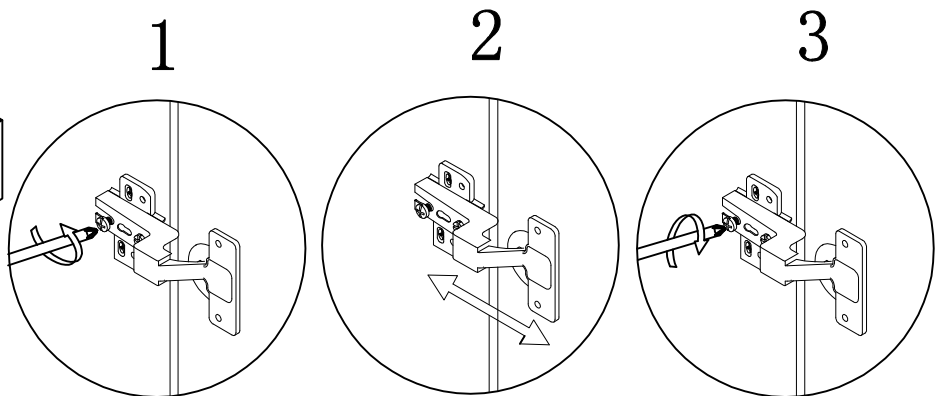
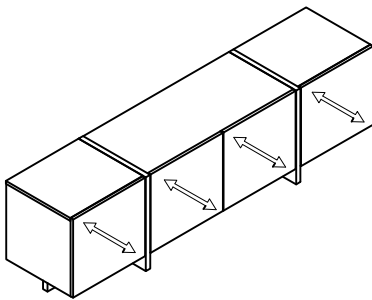

lose this screw shift hinge in/out tighten this screw again

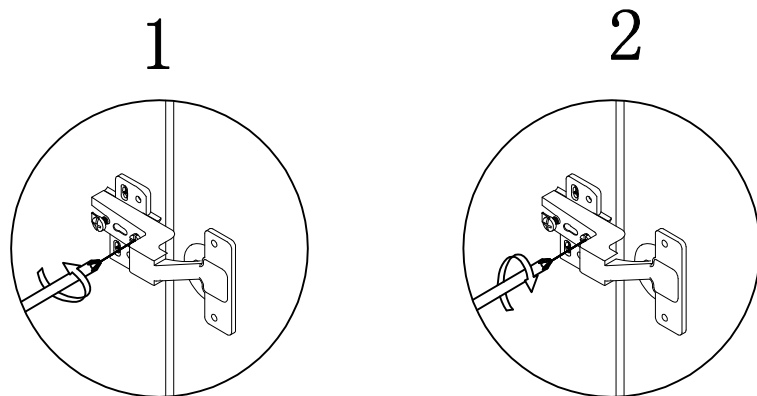
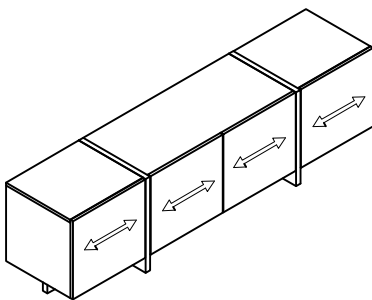



lose this screw would get hinge/door closer to side board

tighten this screw would get hinge/door away from side board

Assembly (EN) /Montageschritte (DE)

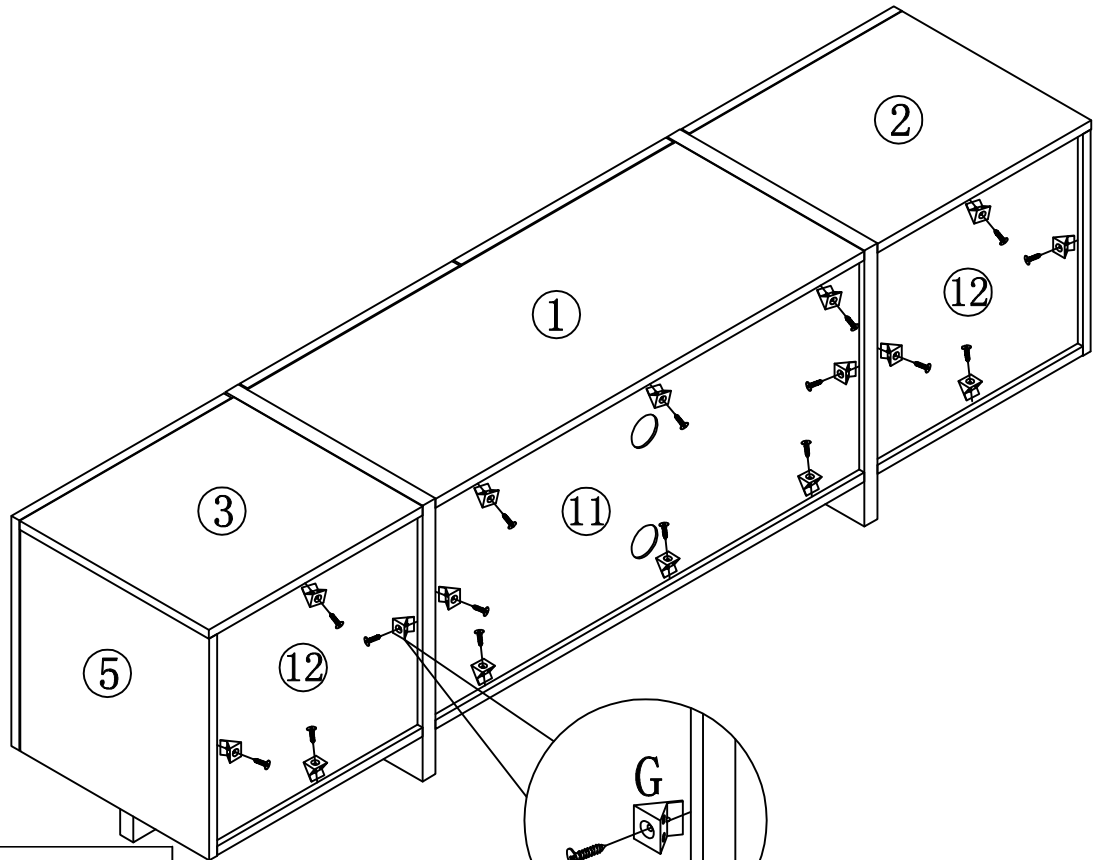
STEP 25



	F * 16PCS
	G * 16PCS

STEP 26

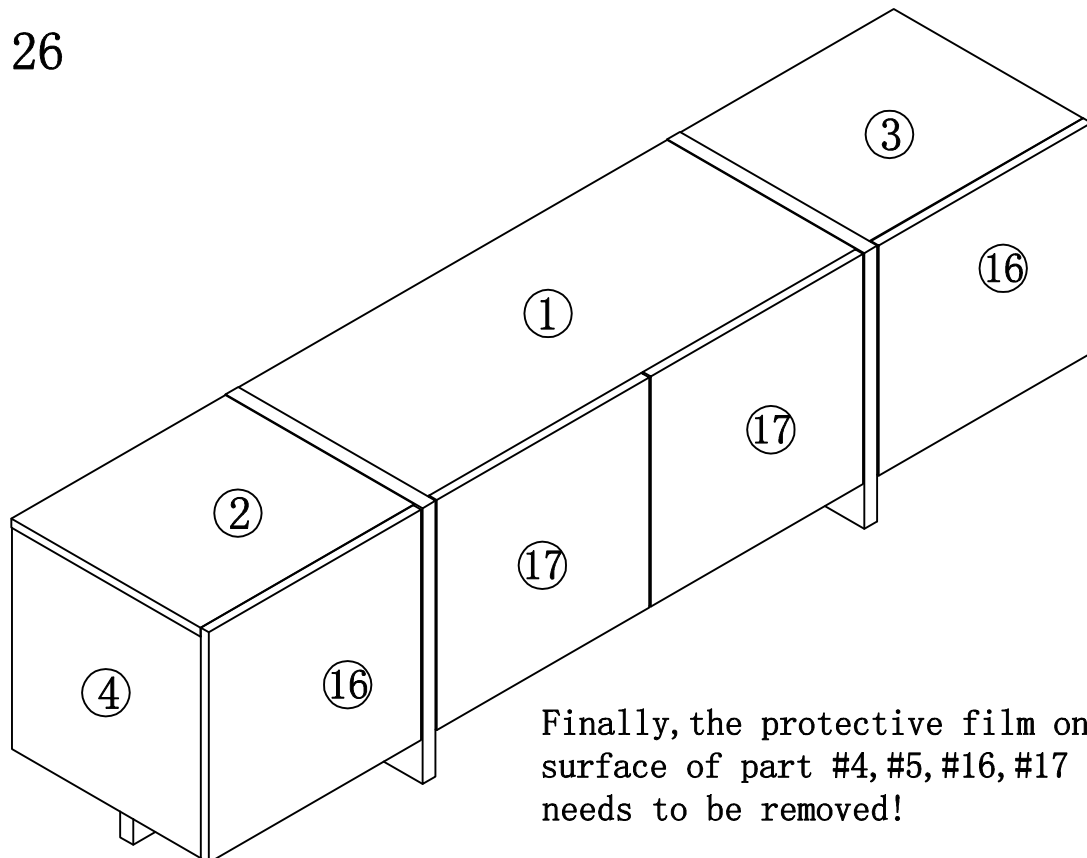

Finally, the protective film on the surface of part #4, #5, #16, #17 needs to be removed!