

ASSEMBLY INSTRUCTIONS

Read this instruction carefully. See hardware and furniture part list for guidance. Be sure all parts are complete, before you assemble. Place all wooden furniture parts on a clean and flat soft surface to prevent from being scratched. Follow the figure to start assembling.

CAUTIONS : 1. Do not FULLY - TIGHTEN the nut or nut bolt until all nut or bolt is ready assembled.
2. Do not OVER - TIGHTEN the nut or bolt to avoid causing damages to the thread.
3. Keep all hardware parts out of reach of children.

NOTE : THE LIST AND QUANTITY SHOWN ARE FOR 1 UNIT ASSEMBLY.
Tool needed : Screwdriver (not provided).

PART LIST		
ITEM	DESCRIPTION	QTY
A	HEADBOARD	1 PC
B	FOOTBOARD	1 PC
C	SIDE RAIL	2 PCS
D	CENTER RAIL	1 PC
E	CENTER SUPPORT LEG	3 PCS
F	CENTER SUPPORT	2 PCS
G	BED SLAT	26 PCS
H	BED LEG	4 PCS

HARDWARE LIST			
ITEM	DESCRIPTION		QTY
1	WOOD SCREW M4 x 20mm		2 PCS
2	WOOD SCREW M3.5 x 16mm		8 PCS
3	PVC BLACK WASHER		4 PCS
4	BED SLAT SIDE FITTER		26 PCS
5	BED SLAT CENTRE FITTER		13 PCS
6	M5 ALLEN KEY (BALL SHAPE)		1 PC

STEP 1

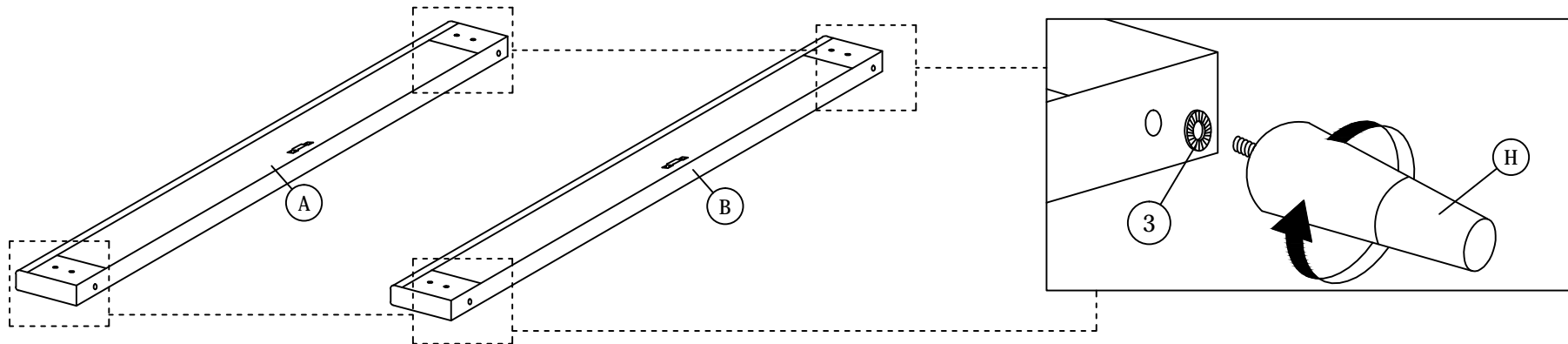

STEP 2

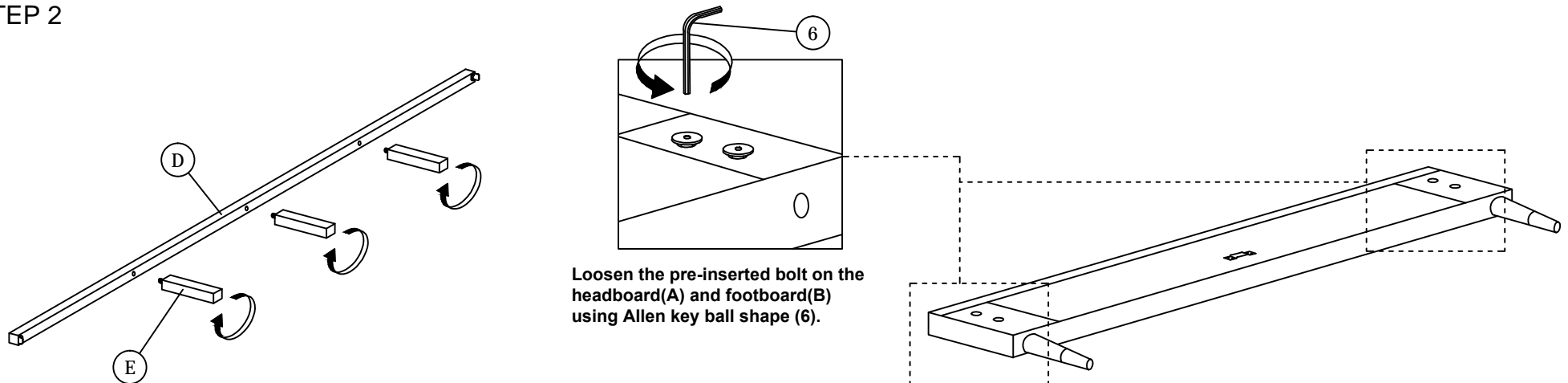

ASSEMBLY INSTRUCTIONS

STEP 3

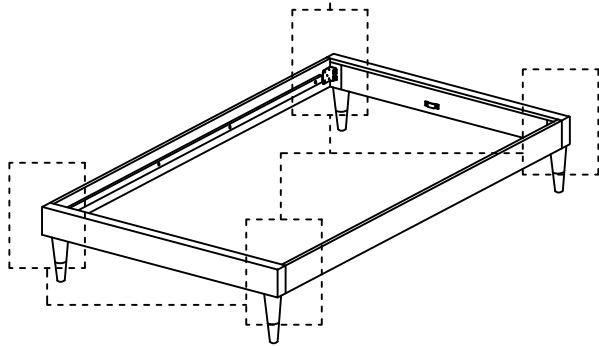
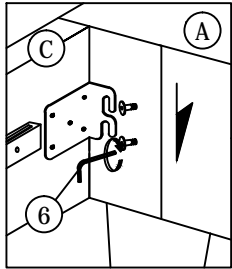

STEP 4

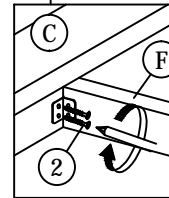
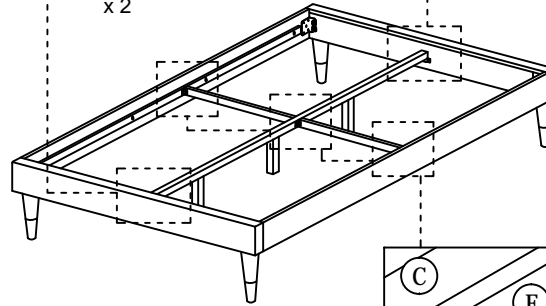
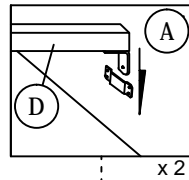

STEP 5

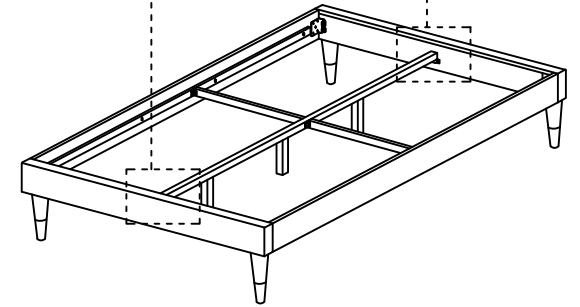
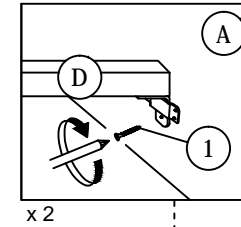

STEP 6

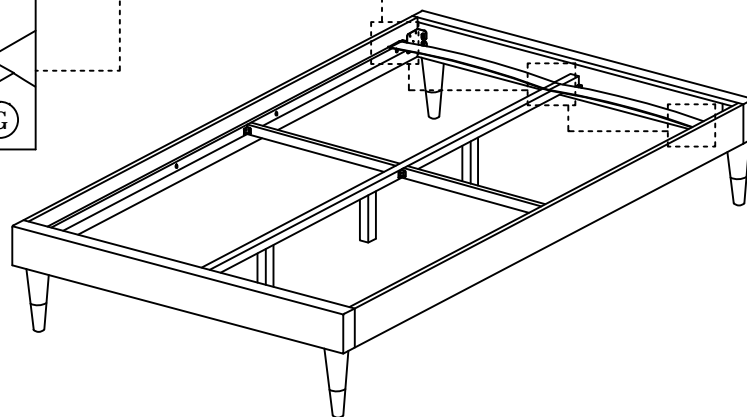
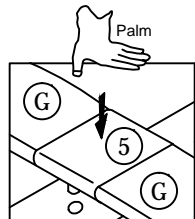
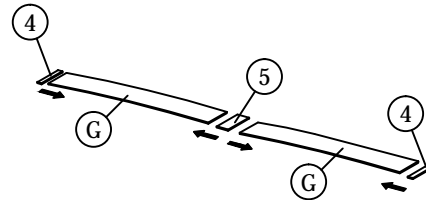
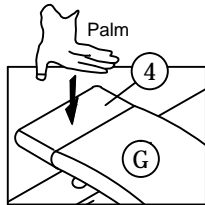

STEP 7

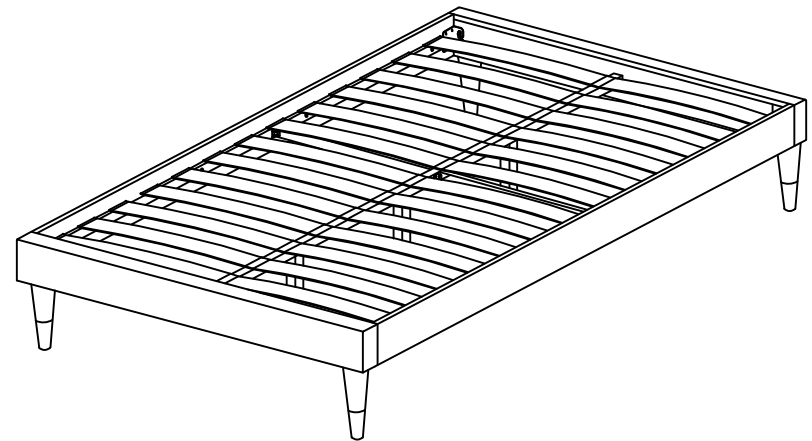

* When moving the bed position, the center support legs must be adjust to be straight to avoid any broken problem.