

# L-Shaped Desk with Shelves

Bureau en L avec étagères

L-förmiger Tisch mit Fächern

Scrivania a Forma di L con Ripiani

Escritorio en L con estantes

L字型デスク（棚付き）

L型带隔板办公桌

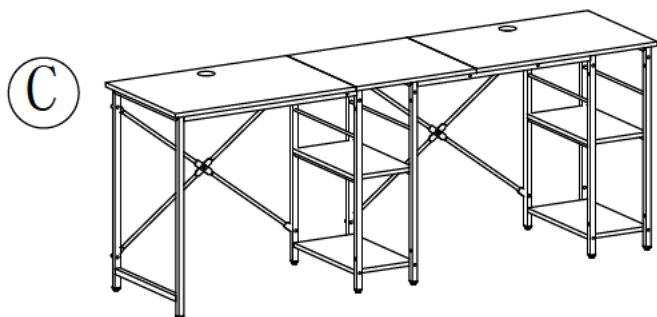
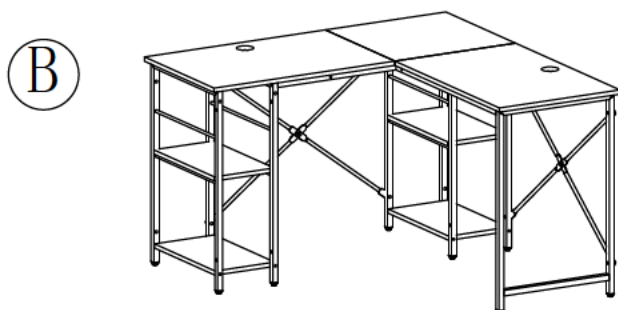
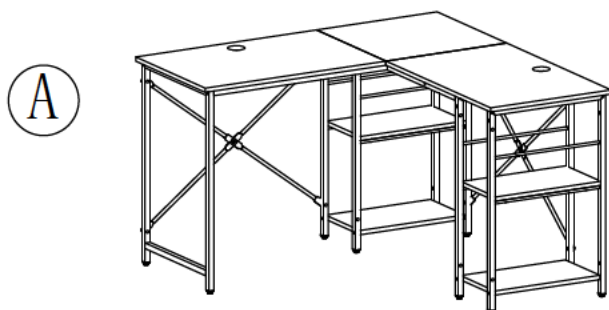

## ASSEMBLY INSTRUCTION

Montageanleitung  
Instructions De Montage  
Istruzioni Per L'assemblaggio  
Instrucciones De Montaje  
組立説明書  
安装说明书



## HELPFUL HINTS

### BEFORE YOU START

- Inspect product packaging to ensure the appearance is good.
- Read the assembly instruction carefully and follow it step by step.
- To avoid any scratching, putting a soft blanket on the floor is suggested.
- Identify, sort and count all the parts with tags.
- Find out installation position according to the drawing and install it in correct steps.

### OTHER

- People needed for assembly: 1-2.
- Estimated assembly time: 0.5-1h.

### CAUTION

- Be cautious when using a power drill or power screwdriver.
- Please be aware to slow down and stop when screw is nearly tight.
- Do Not use any harsh chemicals or abrasive cleaners for this item.
- Push, pull or drag this item carefully.

## ASTUCES UTILES

### AVANT DE COMMENCER

- Inspectez l'emballage du produit pour vous assurer que l'apparence est bonne.
- Lisez attentivement les instructions de montage et suivez-les étape par étape.
- Pour éviter toute rayure, posez une couverture douce sur le sol est suggéré.
- Identifiez, trie et comptez toutes les pièces avec des étiquettes.
- Trouver la position d'installation selon le dessin et l'installer dans les étapes correctes.

### AUTRE

- Personnes nécessaires pour l'assemblage : 1-2.
- Temps de montage estimé : 0.5-1 h.

### AVERTIR

- Soyez prudent lorsque vous utilisez une perceuse électrique ou un tournevis électrique.
- Veuillez être conscient de ralentir et d'arrêter lorsque la vis est presque serrée.
- N'utilisez pas de produits chimiques corrosifs ou de nettoyants abrasifs pour cet article.
- Poussez, tirez ou tirez cet article avec précaution.

## CONSEJOS ÚTILES

### ANTES DE EMPEZAR

- Inspeccione el paquete del producto para asegurarse de que la apariencia es buena.
- Lea atentamente las instrucciones de montaje y sígala paso a paso.
- Para evitar rayas, se sugiere poner una manta suave en el suelo.
- Identifique, clasifique y enumere todas las piezas con etiquetas.
- Averigüe la posición de instalación según el dibujo e instálela en los pasos correctos.

### OTROS

- Personas necesarias para el montaje: 1-2.
- Tiempo de montaje estimado: 0.5-1 h.

### PRECAUCIÓN

- Tenga cuidado al utilizar un taladro eléctrico o un destornillador eléctrico.
- Tenga en cuenta que debe hacerlo más despacio y detenerse cuando el tornillo esté casi apretado.
- No utilice productos químicos agresivos ni limpiadores abrasivos para este artículo.
- Empuje, tire o arrastre este elemento con cuidado.

## SUGGERIMENTI UTILI

### PRIMA DI INIZIARE

- Controllare la confezione del prodotto per assicurarsi che sia in buono stato.
- Leggere con attenzione le istruzioni per l'assemblaggio e seguirle passo dopo passo.
- Per evitare graffi al pavimento, suggeriamo di stendervi una coperta morbida.
- Identificare, suddividere e contare tutte le parti con etichetta.
- Trovare la posizione adatta per il montaggio in base al disegno e montare lo scaffale seguendo correttamente i vari passaggi.

### ALTRO

- Persone necessarie per l'assemblaggio: 1-2.
- Tempo di assemblaggio stimato: 0.5-1 ora.

### ATTENZIONE

- Prestare molta attenzione quando si utilizza un trapano elettrico o un cacciavite elettrico.
- Rallentare con accortezza e fermarsi quando una vite è già sufficientemente serrata.
- Non utilizzare prodotti chimici aggressivi o detergenti abrasivi su questo articolo.
- Spingere, tirare o trascinare questo articolo con cautela.

## NÜTZLICHE HINWEISE

### ⚠ BEVOR SIE BEGINNEN

- Überprüfen Sie die Produktverpackung auf Schäden.
- Lesen Sie sich die Montageanleitung sorgfältig durch und befolgen Sie sie Schritt für Schritt.
- Um etwaiges Zerkratzen zu vermeiden, wird das Auslegen einer weichen Decke auf dem Boden empfohlen.
- Identifizieren, sortieren und zählen Sie alle Teile mit Tags nach.
- Identifizieren Sie die Montageposition gemäß der Zeichnung und bauen Sie das Regal den richtigen Schritten entsprechend auf.



### SONSTIGES

- Für den Zusammenbau erforderliche Anzahl an Menschen: 1-2.
- Ungefähre Montagedauer: 0.5-1 h.

### ⚠ VORSICHT

- Seien Sie bei der Verwendung einer Bohrmaschine oder eines Akkuschraubers vorsichtig.
- Bitte vergessen Sie nicht darauf, langsamer zu werden und zu stoppen, sobald die Schraube fast festgezogen ist.
- Verwenden Sie keinerlei aggressive Chemikalien oder scheuernden Reinigungsmittel für dieses Produkt.
- Schieben oder ziehen Sie dieses Produkt vorsichtig.

## 温馨提示

### ⚠ 安装前注意事项

- 检查产品包装，确保外观良好。
- 仔细阅读安装说明，按步骤操作。
- 为了避免刮伤，建议在地板上放一条柔软的毯子。
- 标识、分类和清点所有部件。
- 根据图形找到安装孔位，按正确步骤安装。



### 其他:

- 组装所需人员: 1-2人。
- 预计组装时间: 0.5-1小时。

### ⚠ 注意:

- 小心使用电钻或电动螺丝刀。
- 当螺丝快要拧紧时，请注意减速。
- 不要使用任何刺激性化学物质或清洗剂。
- 当推、拉或拖动产品时，注意小心谨慎，防止损坏。

## 役に立つヒント

### ⚠ 組立の場所を確保し、順番通りに組み立てる

- 組立場所（充分広くて平たい場 所）を確保してください。
- 床や壁、商品を傷つけないように、商品の下に厚めの布や段ボールなどを敷いてください。
- 組立の順番を守らないと、組立できなくなったり、商品を傷つけたりします。



### その他

- 組み立てに必要な人: 1-2。
- 組立時間: 約0.5~1時間。

### ⚠ 部品を確認する

- ネジ類などの部品番号、形状を説明書の部品一覧で確認してください。
- 部品をなくさないように纏めて置いてください。
- 部品を取り出すときに使う分だけ取り出してください。

# DETAILS

DETAILS  
DÉTAILS/POINTS DE MONTAGE  
NOTE PARTICOLARI

DETALLES  
組み立てのポイント  
詳細情報

UNIT:INCH/CM/厘米

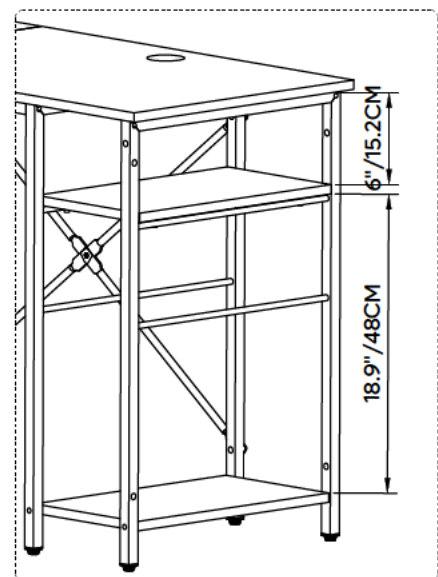
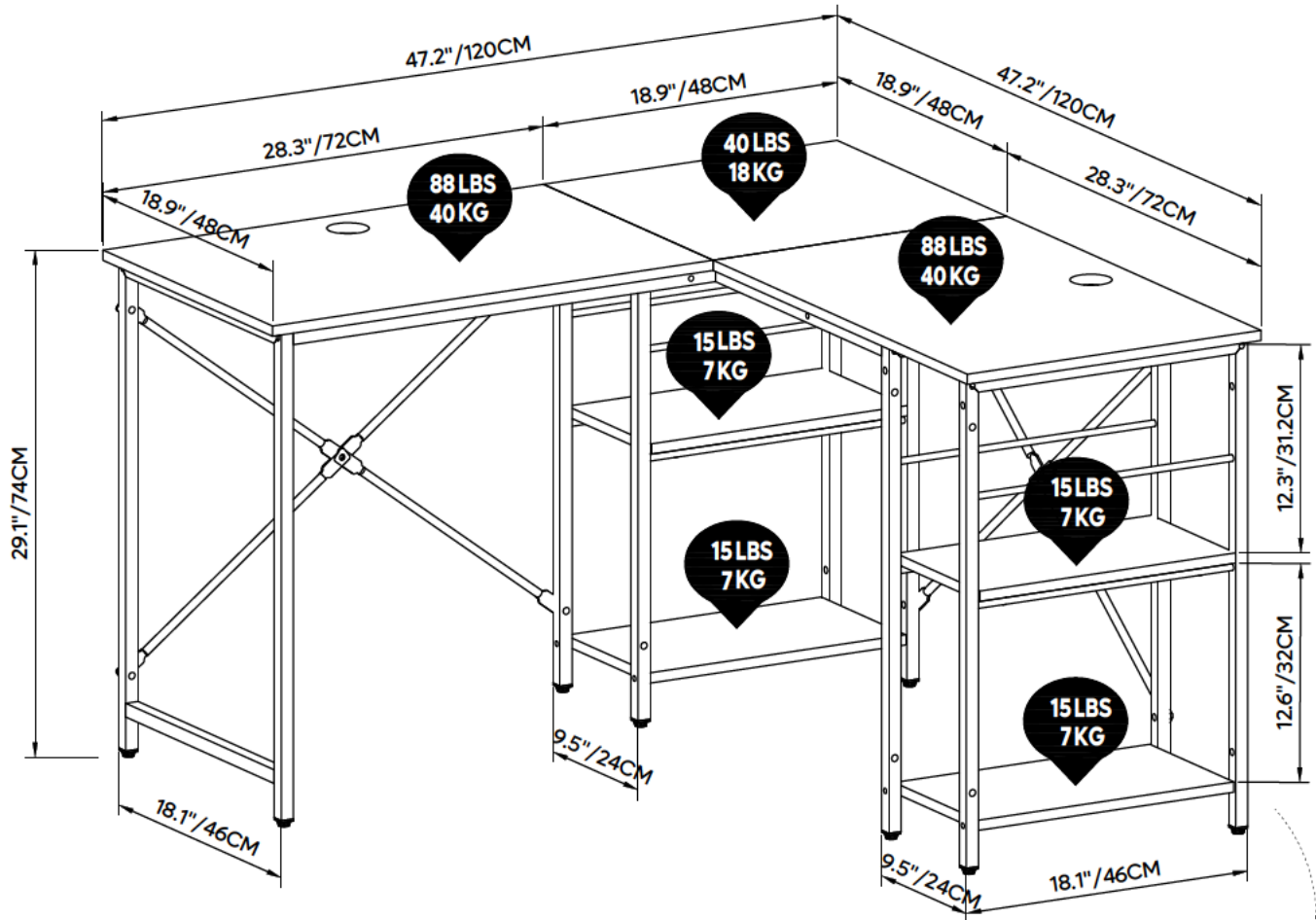

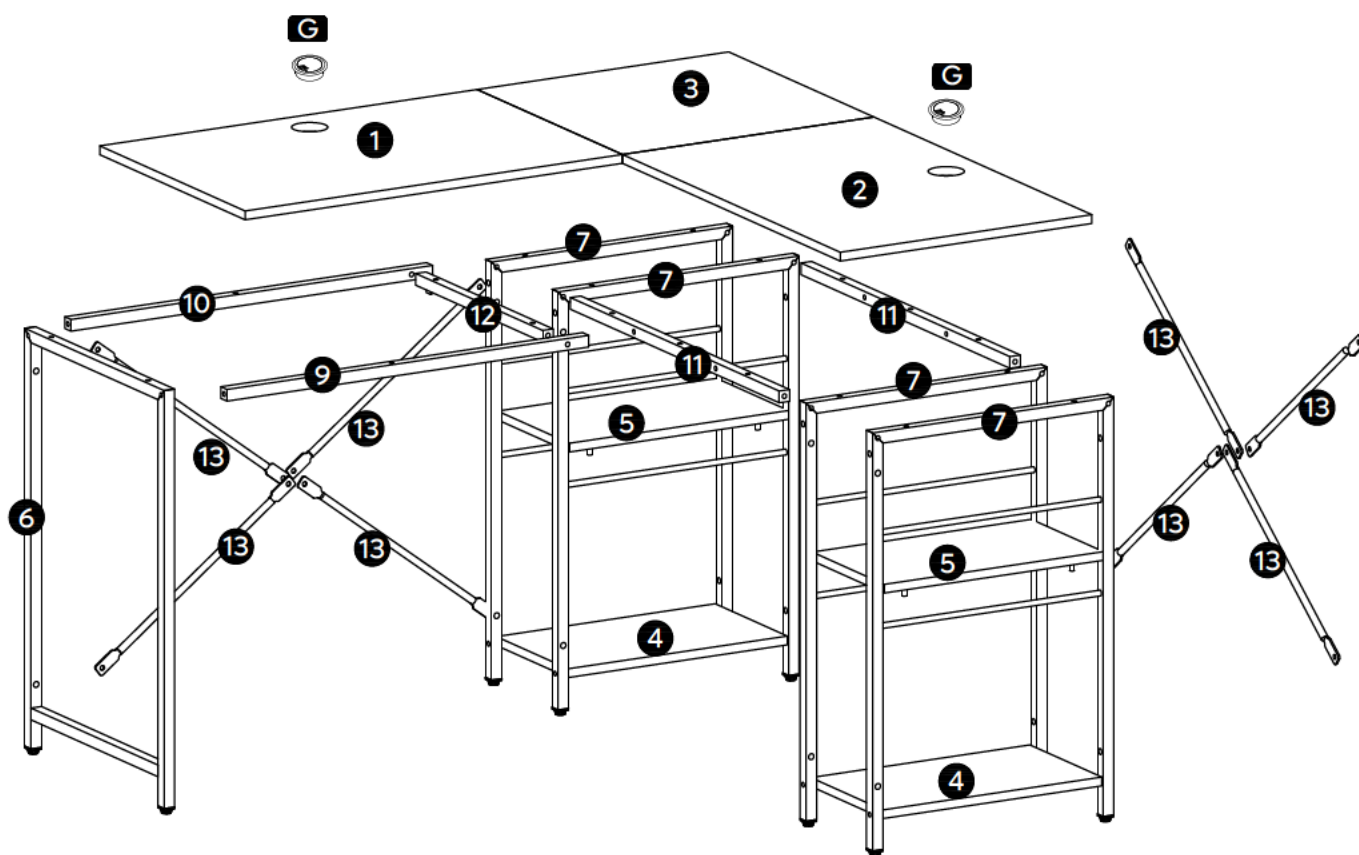

# PART LIST

STÜCKLISTE  
LISTE DES PIÈCES  
ELENCO DEI PEZZI

LISTA DE PIEZAS  
部品の確認  
部件清单

1



X1

2

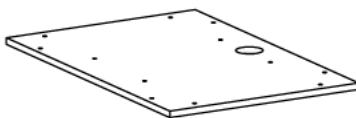

X1

3

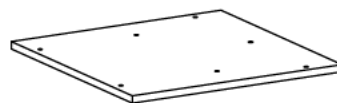

X1

4



X2

5



X2

6

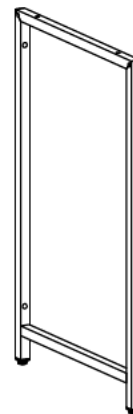

X1

7

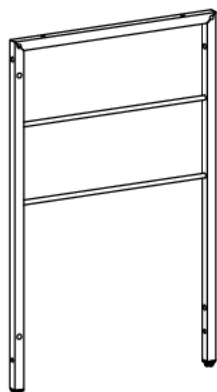

X4

8

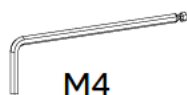

M4

X1

9



X1

10



X1

11



X2

12



X1

13







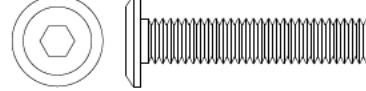

X8

# ACCESSORY LIST

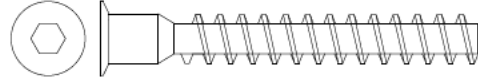
ZUBEHÖRLISTE  
LISTE DES ACCESSOIRES  
ELENCO DEGLI ACCESSORI

LISTA DE ACCESORIOS  
付属品部品の確認  
配件清单

<b>A</b>	M6x12mm	2	
<b>B</b>	M6x30mm	36+2	
<b>C</b>	M6	11+1	
<b>D</b>	ST7x50mm	8+1	
<b>E</b>	M6-Ø8x13mm	8+1	
<b>F</b>	Ø8mm	8+1	
<b>G</b>	Ø60mm	2	



1

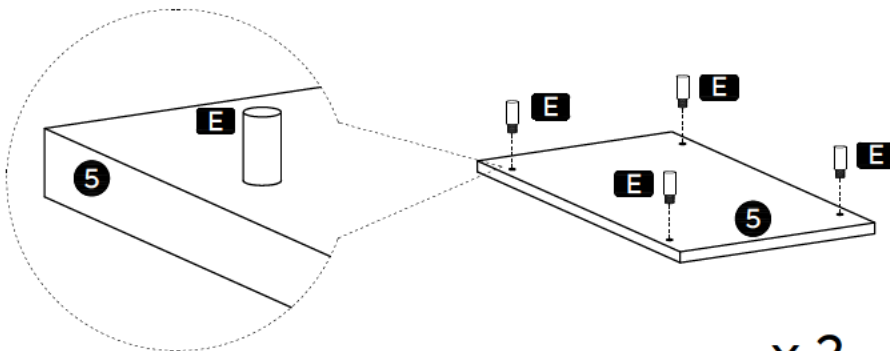

x 2

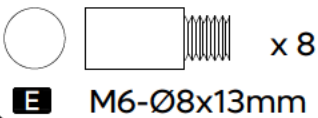

## 2

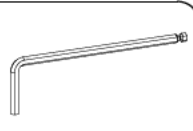
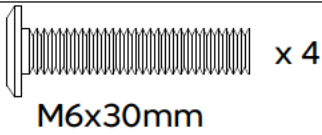
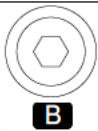
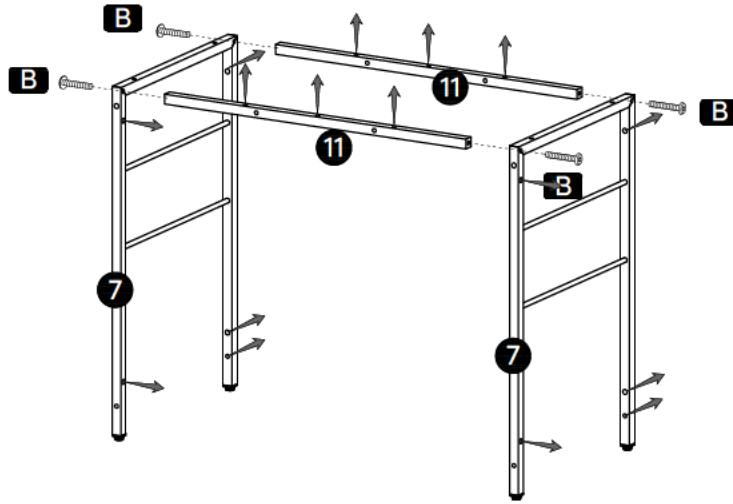

## 3

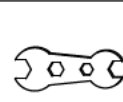
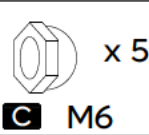
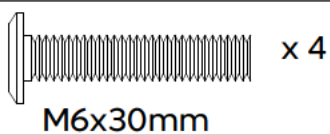
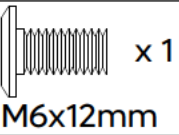
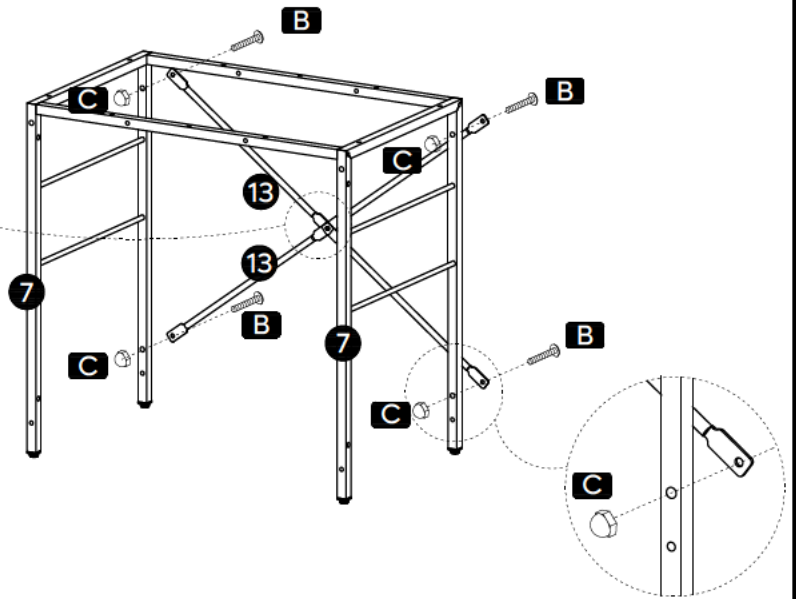
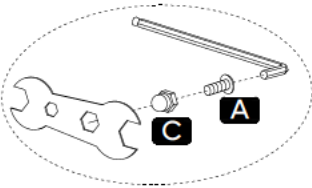
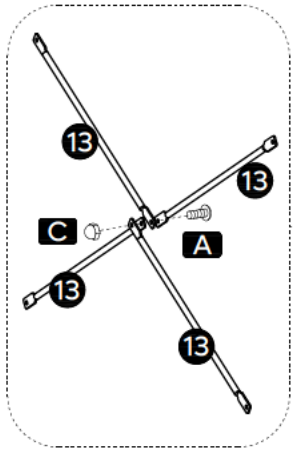

# 4

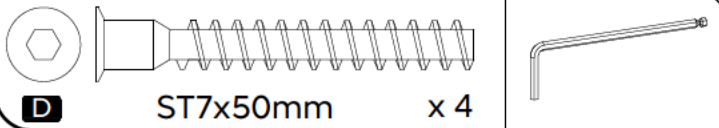
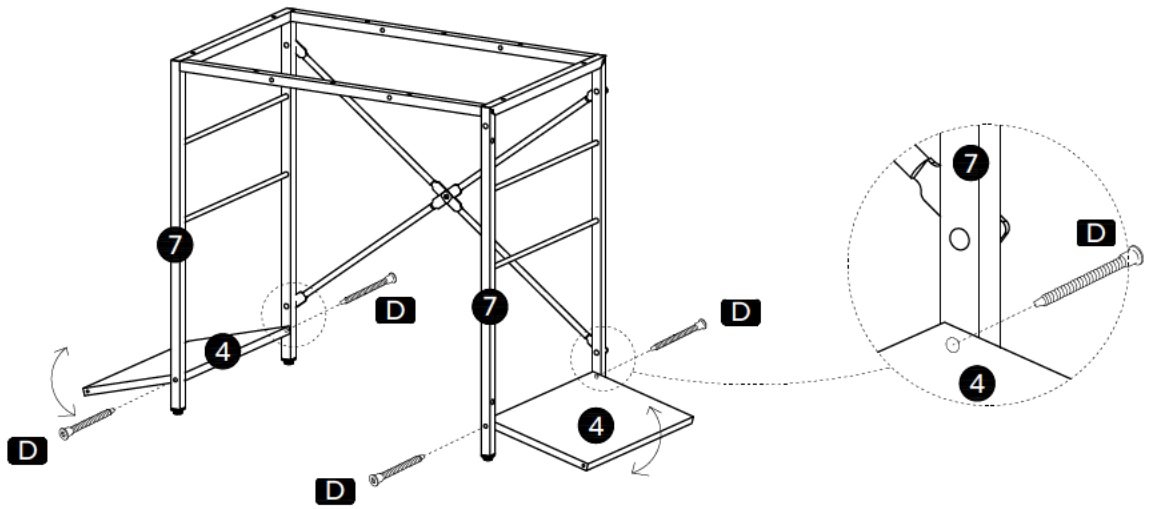

# 5

- ※ Two persons are needed.
- ※ Deux personnes sont nécessaires.
- ※ Zwei Personen sind erforderlich.
- ※ Sono necessarie due persone.
- ※ Se necesitan dos personas.
- ※ 必ず2人で作業してください。
- ※ 需要另1个人协助。

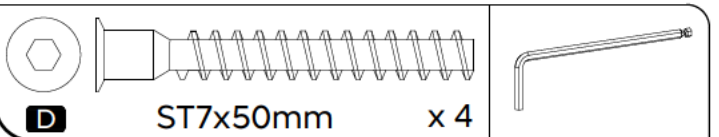
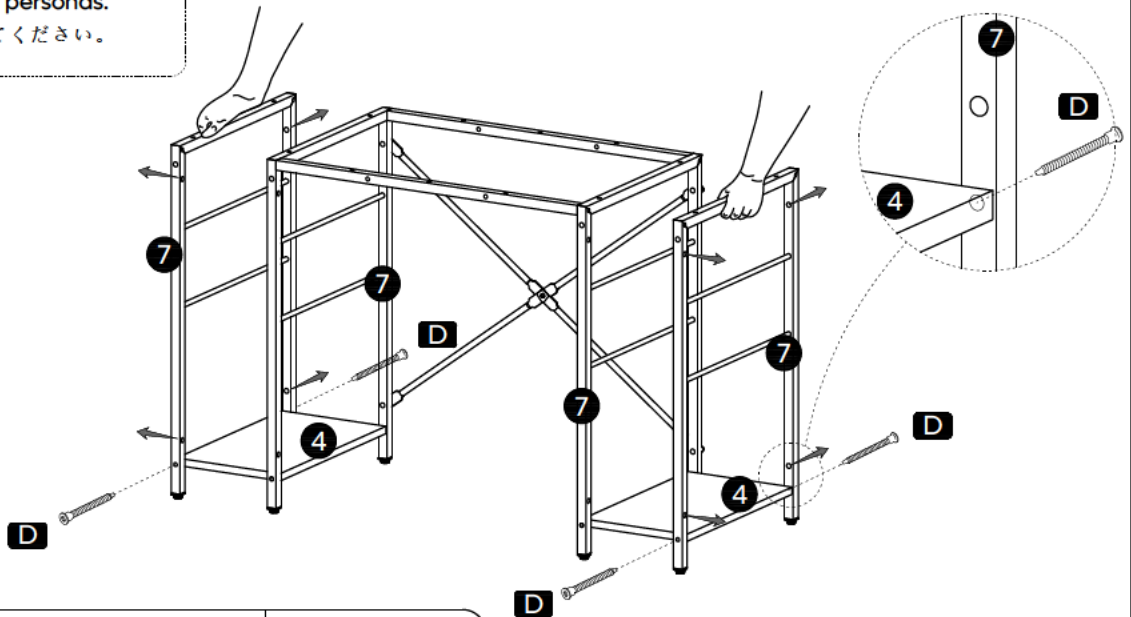

A

Style A: Step 6-12  
Style A : Étape 6-12  
Ausführung A: Schritt 6-12  
Stile A: Step 6-12  
Estilo A: paso 6-12  
スタイルA: ステップ 6-12  
安裝方式A: 步驟 6-12

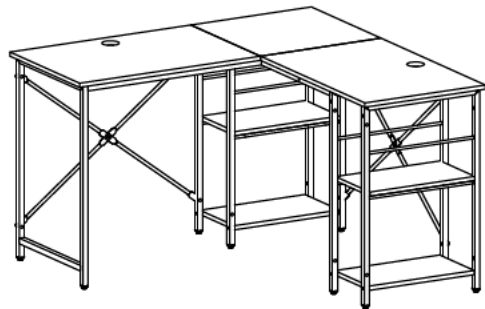

B

Style B: Step 13-19  
Style B : Étape 13-19  
Ausführung B: Schritt 13-19  
Stile B: Step 13-19  
Estilo B: paso 13-19  
スタイルB: ステップ 13-19  
安裝方式B: 步驟 13-19

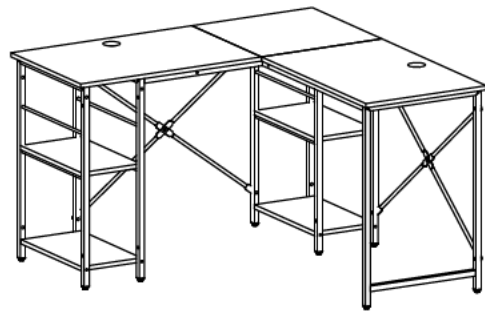

C

Style C: Step 6,20-25  
Style C : Étape 6,20-25  
Ausführung C: Schritt 6,20-25  
Stile C: Step 6,20-25  
Estilo C: paso 6,20-25  
スタイルC: ステップ 6,20-25  
安裝方式C: 步驟 6,20-25

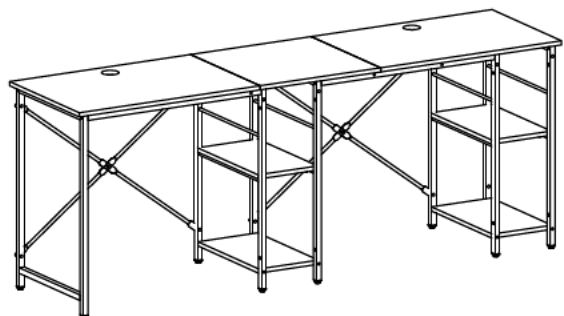

# 6

(A) (C)

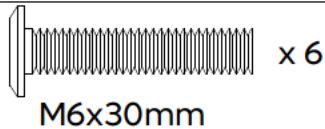
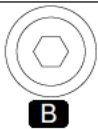
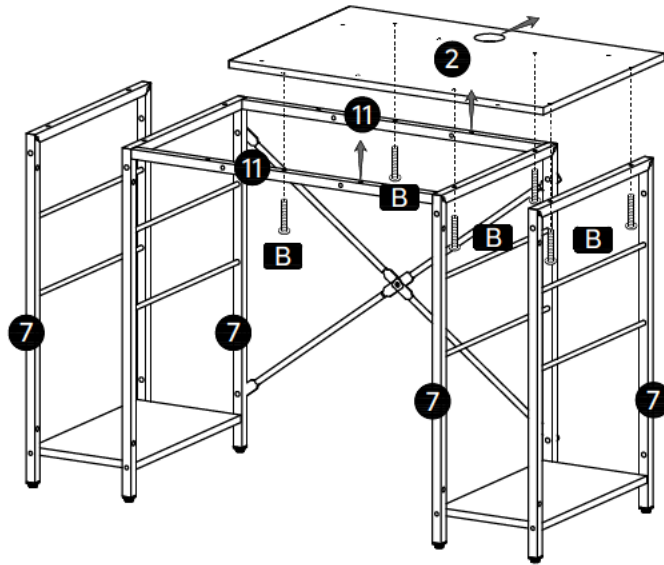

x 6

M6x30mm



# 7

(A)

80%  
 80% tighten  
 80% serré  
 80% festziehen  
 Serraggio al 80%  
 80% reforzado  
 80%締め付け  
 80%锁紧

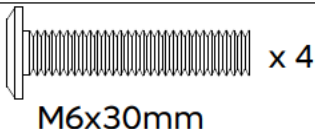
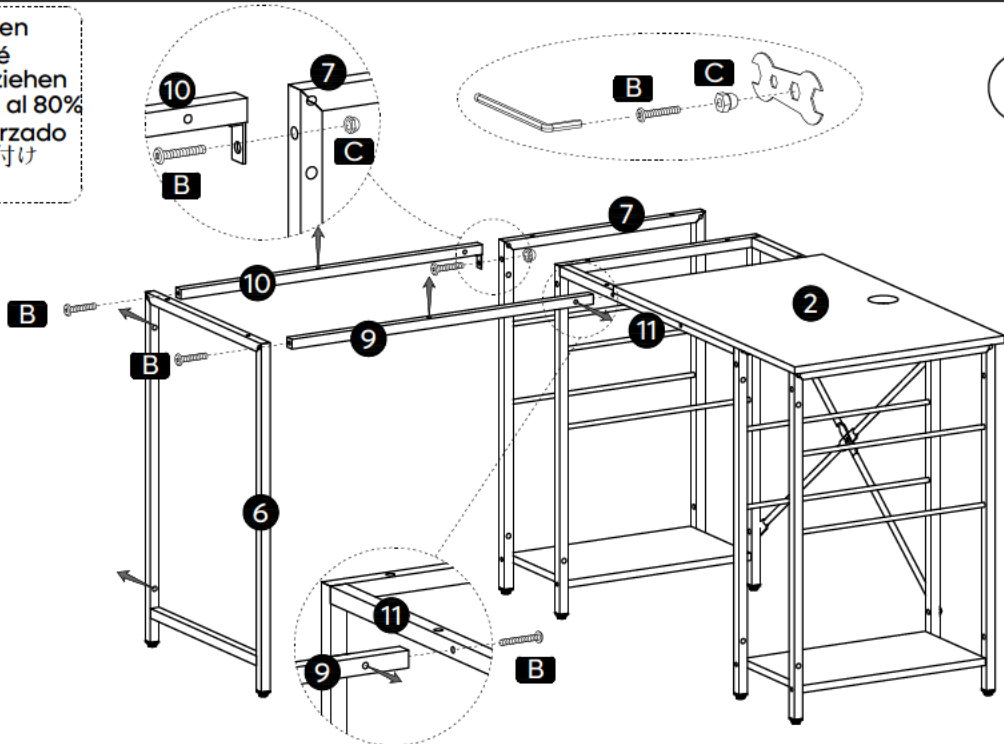

x 4

M6x30mm



x 1

M6

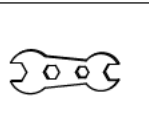



# 8

 100% tighten  
 100 % serré  
 100% festziehen  
 Serraggio al 100%  
 100 % reforzado  
 100%締め付け  
 100%锁紧

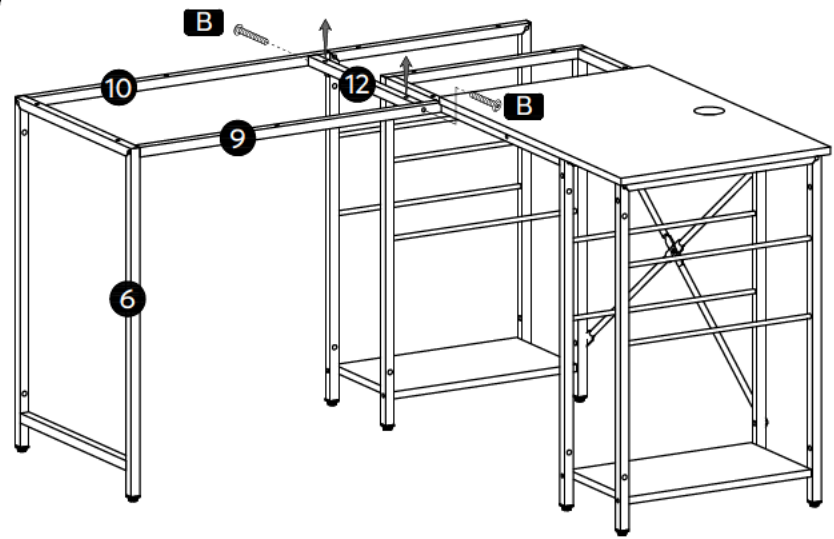
(A)







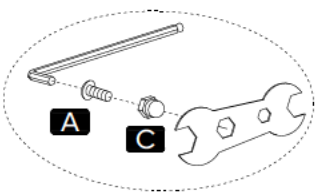
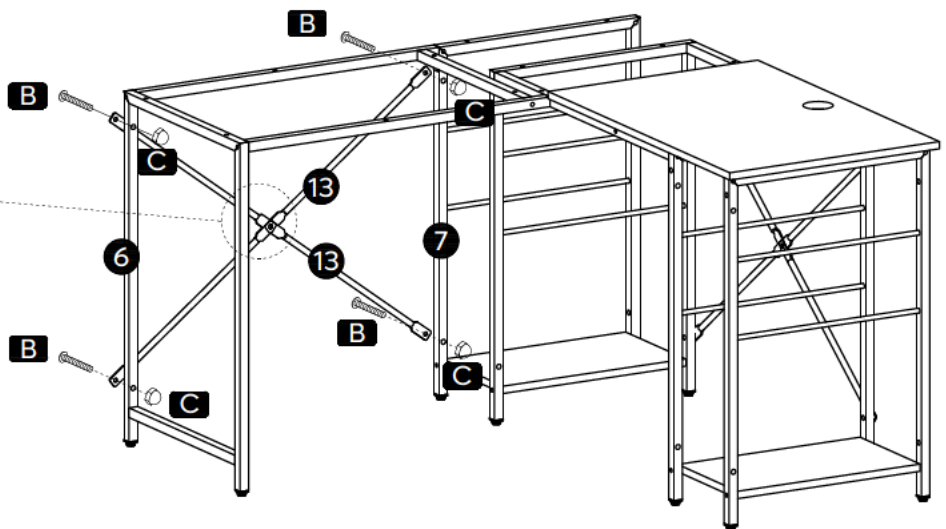
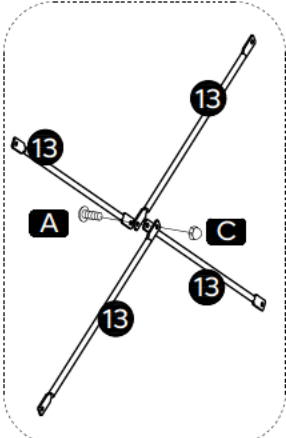

		x 2	
<b>B</b>	M6x30mm		

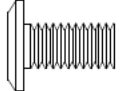
# 9

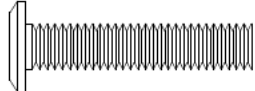
(A)

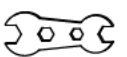

		x 1			x 4		x 5		
<b>A</b>	M6x12mm		<b>B</b>	M6x30mm		<b>C</b>	M6		

# 10

※This hole does not assemble screws, but only indicates the installation direction.  
 ※Ce trou n'est pas équipé de vis, mais indique seulement la direction d'installation.  
 ※Dieses Loch montiert keine Schrauben, sondern zeigt nur die Einbaurichtung an.  
 ※Questo foro non assembla viti, ma indica solo la direzione di installazione.  
 ※Este agujero no está equipado con tornillos, pero sólo indica la dirección de instalación.  
 ※この穴はネジを組み立てるのではなく、取り付け方向を示すだけです。  
 ※此孔不组装螺丝，仅指示安装方向。

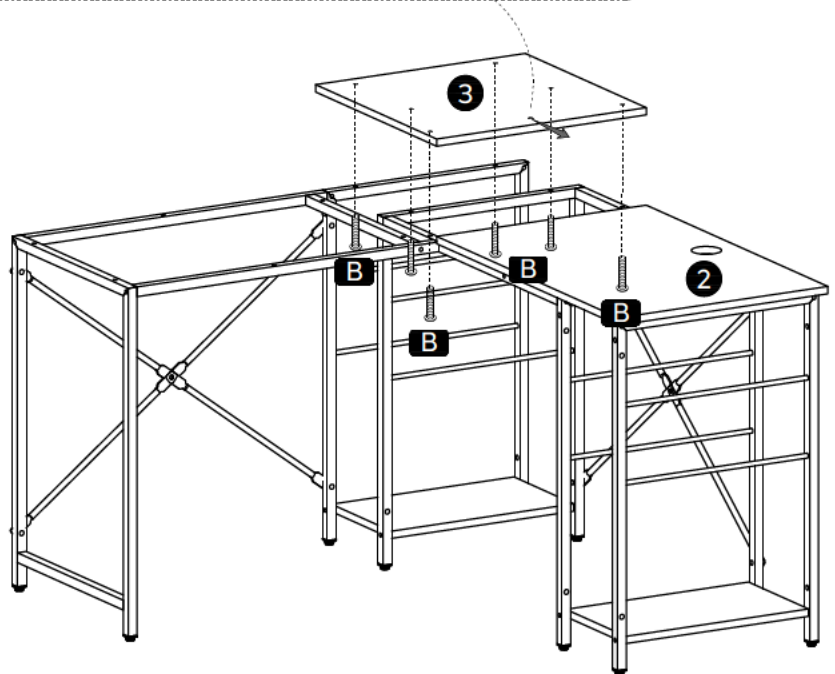

**B** M6x30mm x 6

# 11

100% tighten  
 100 % serré  
 100% festziehen  
 Serraggio al 100%  
 100 % reforzado  
 100%締め付け  
 100%锁紧

**A**

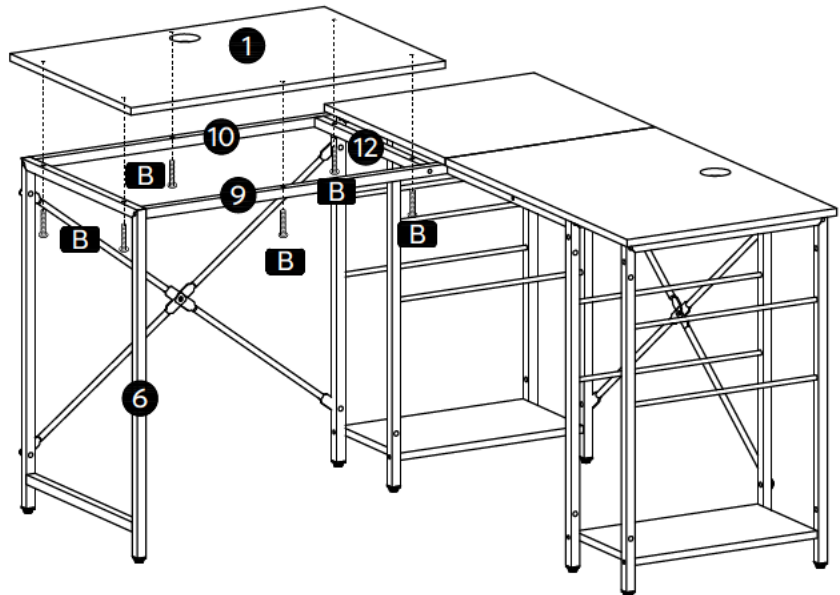

**B** M6x30mm x 6



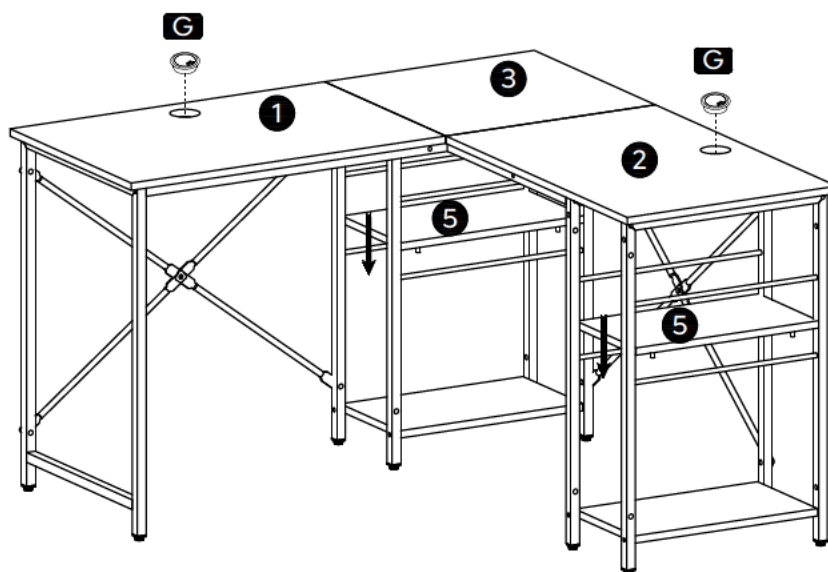
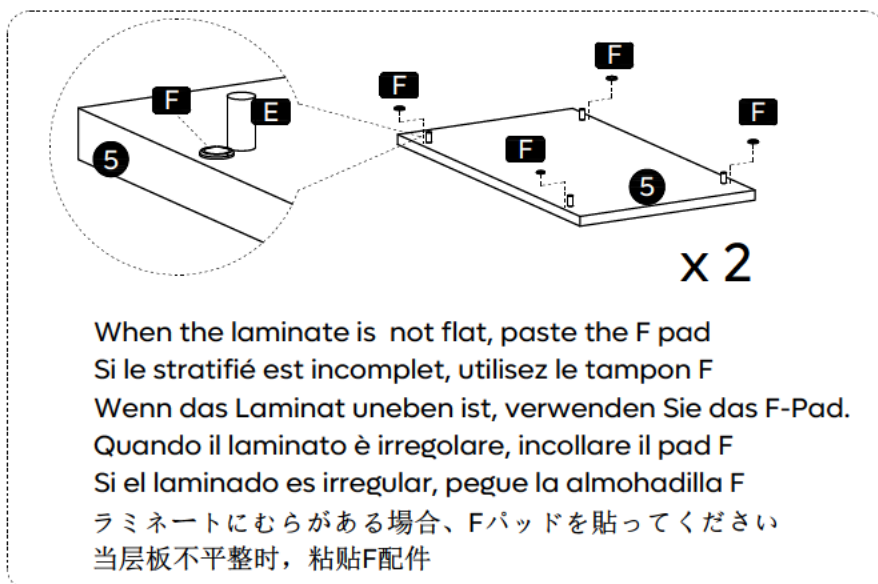

x 2

G Ø60mm



x 8

F Ø8mm

13

(B)

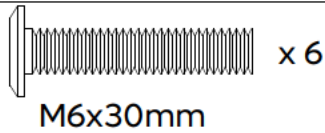
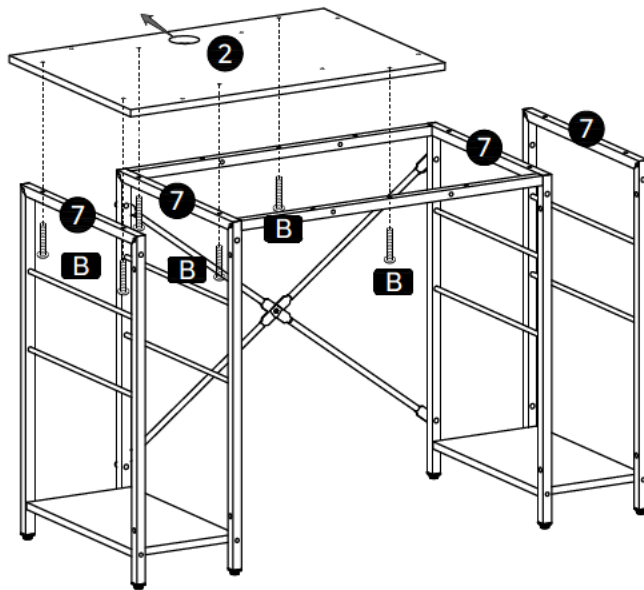

14

(B)

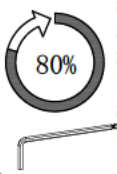

80% tighten  
80% serré  
80% festziehen  
Serraggio al 80%  
80% reforzado  
80%締め付け  
80%锁紧

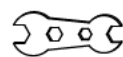
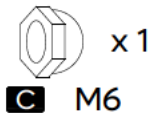
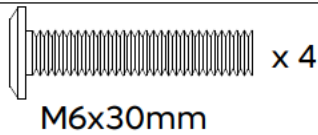
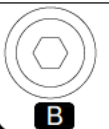
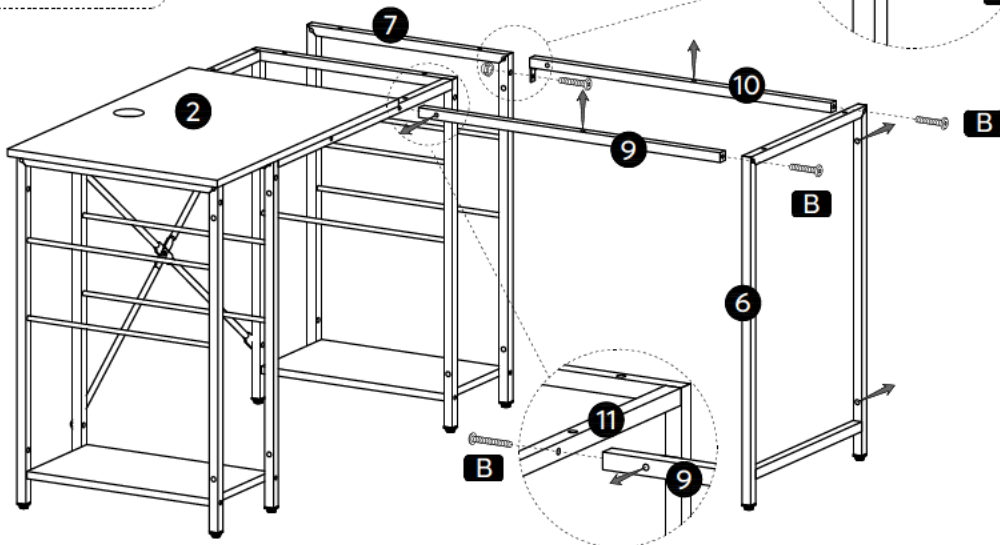
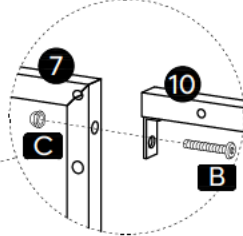
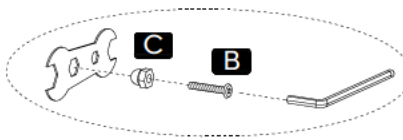

# 15

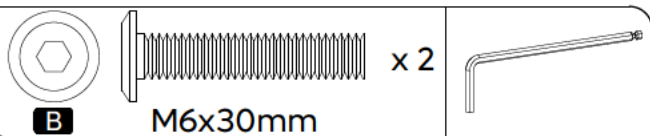
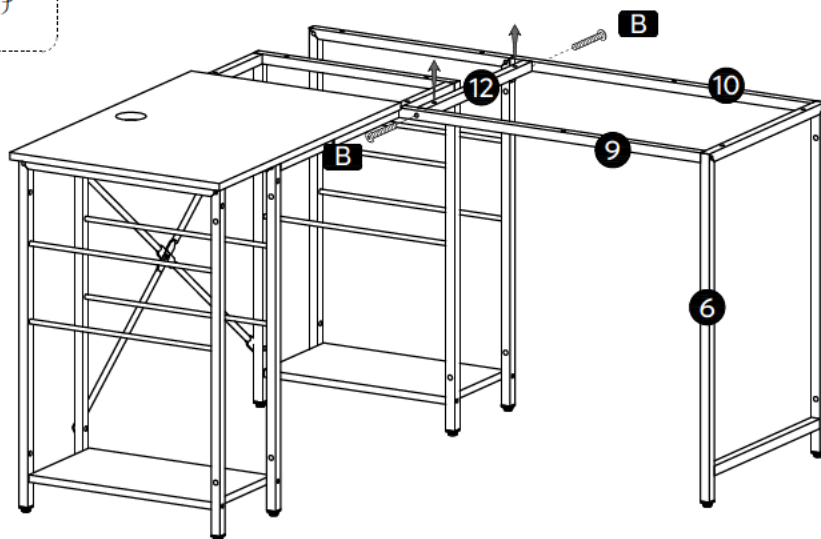

 100% tighten  
 100 % serré  
 100% festziehen  
 Serraggio al 100%  
 100 % reforzado  
 100%締め付け  
 100%锁紧

(B)

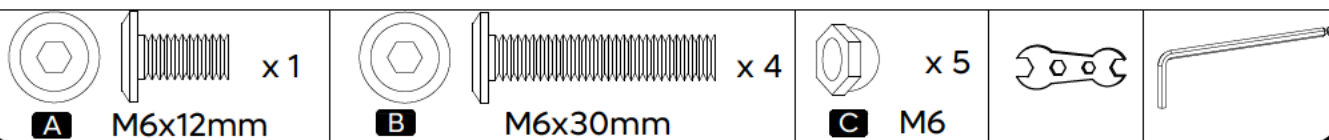
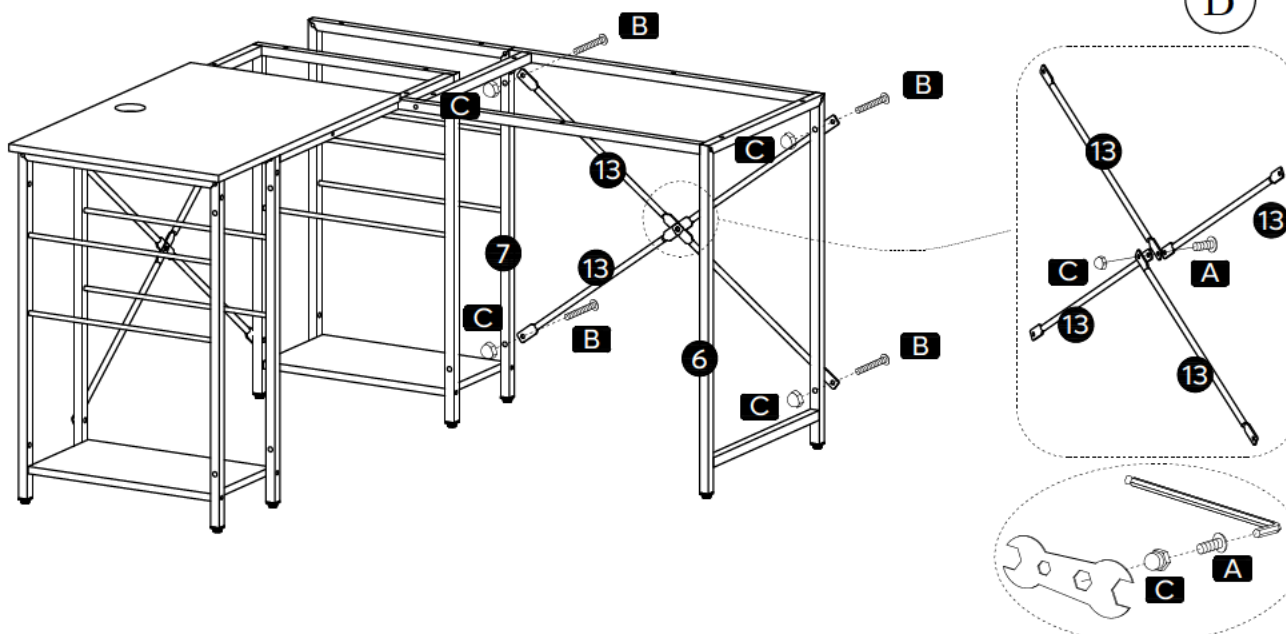

# 16

(B)



# 17

※This hole does not assemble screws, but only indicates the installation direction.  
 ※Ce trou n'est pas équipé de vis, mais indique seulement la direction d'installation.  
 ※Dieses Loch montiert keine Schrauben, sondern zeigt nur die Einbaurichtung an.  
 ※Questo foro non assembla viti, ma indica solo la direzione di installazione.  
 ※Este agujero no está equipado con tornillos, pero sólo indica la dirección de instalación.  
 ※この穴はネジを組み立てるのではなく、取り付け方向を示すだけです。  
 ※此孔不组装螺丝，仅指示安装方向。

(B)

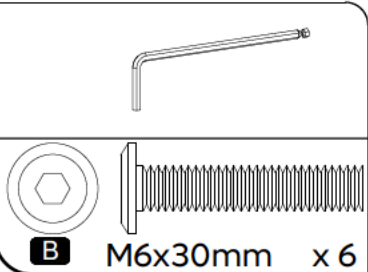
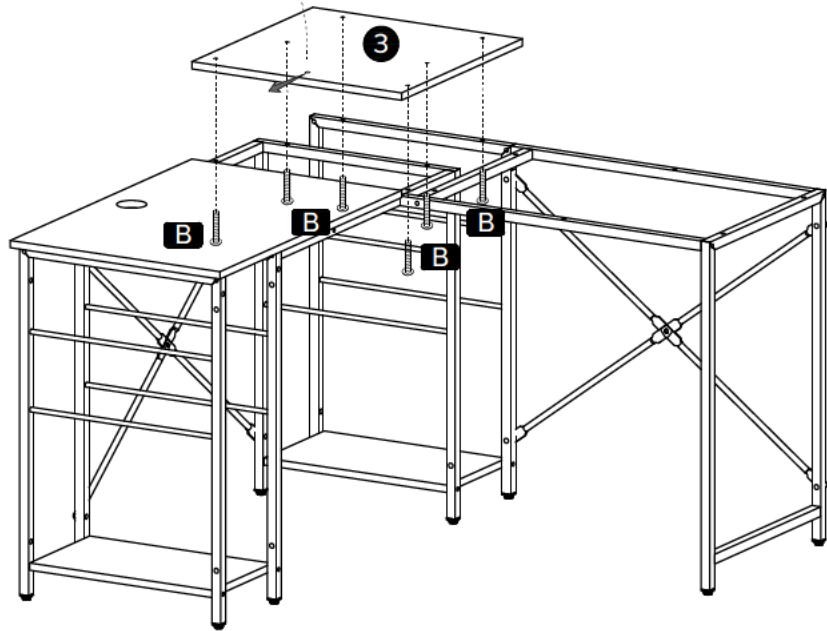

# 18

100% tighten  
 100 % serré  
 100% festziehen  
 Serraggio al 100%  
 100 % reforzado  
 100%締め付け  
 100%锁紧

(B)

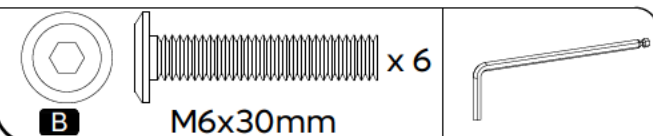
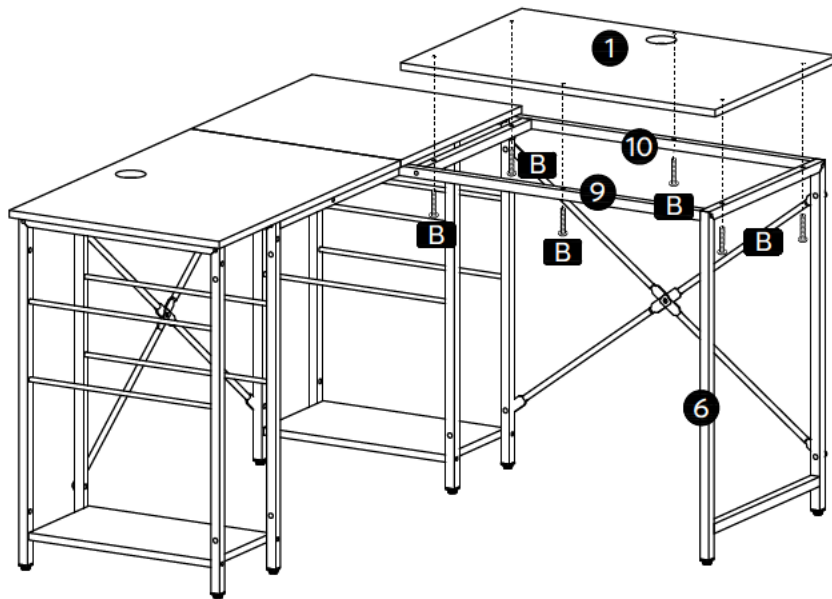

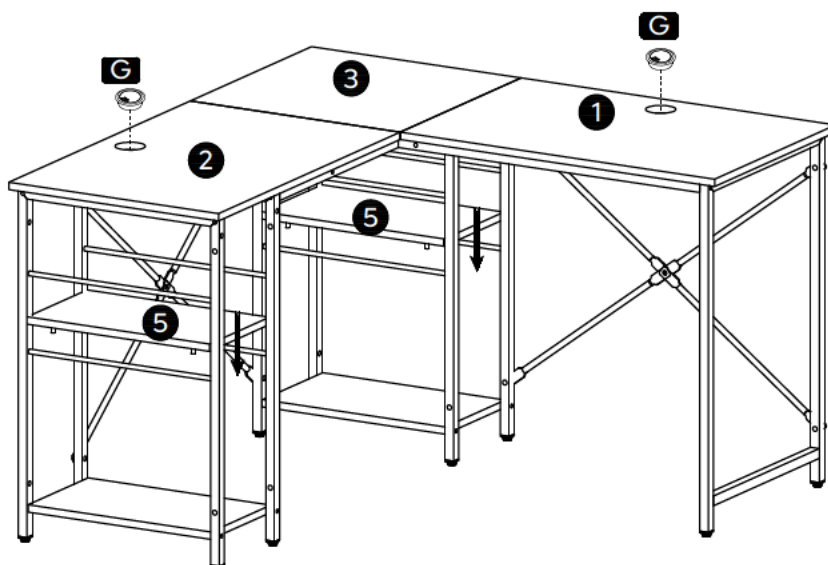
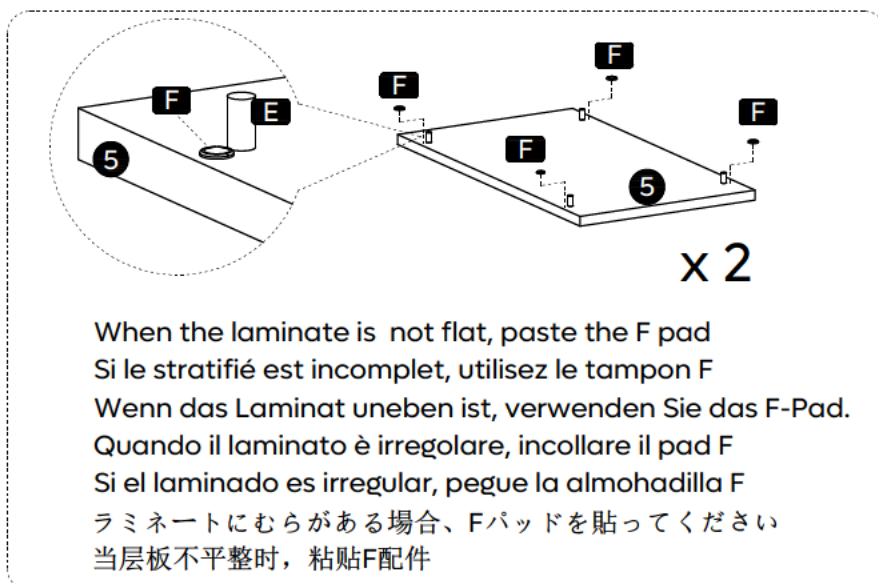

x 2

G Ø60mm



x 8

F Ø8mm

# 20

 80% tighten  
 80% serré  
 80% festziehen  
 Serraggio al 80%  
 80% reforzado  
 80%締め付け  
 80%锁紧

(C)

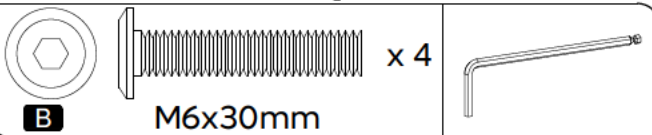
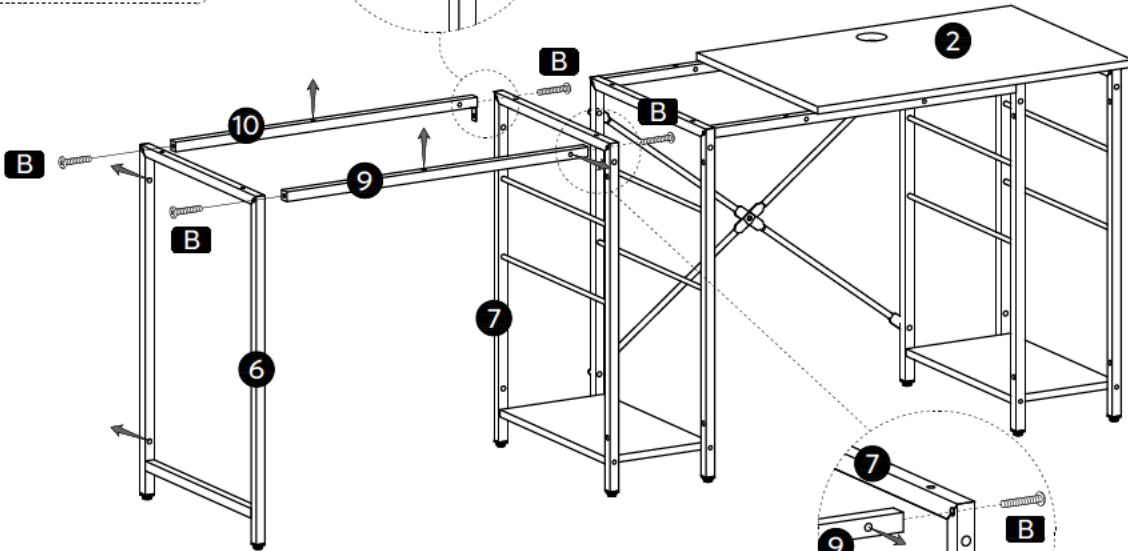

# 21

 100% tighten  
 100% serré  
 100% festziehen  
 Serraggio al 100%  
 100% reforzado  
 100%締め付け  
 100%锁紧

(C)

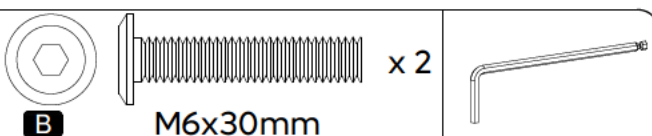
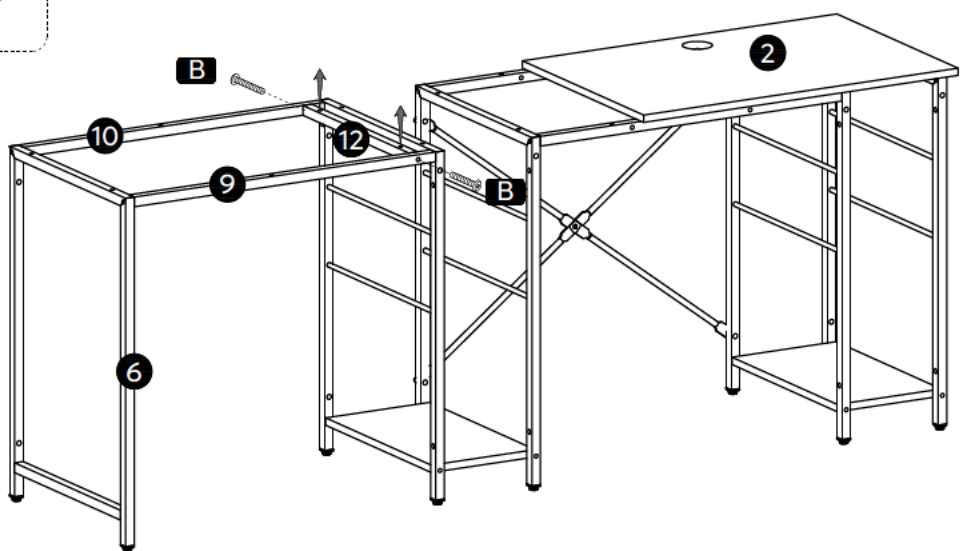

(C)

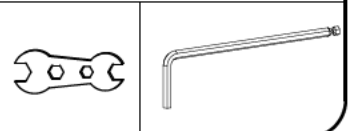
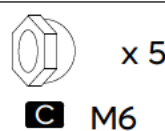
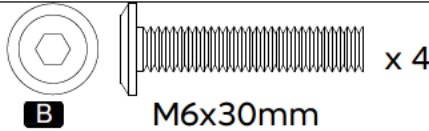
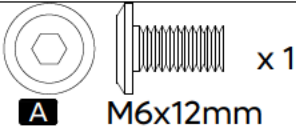
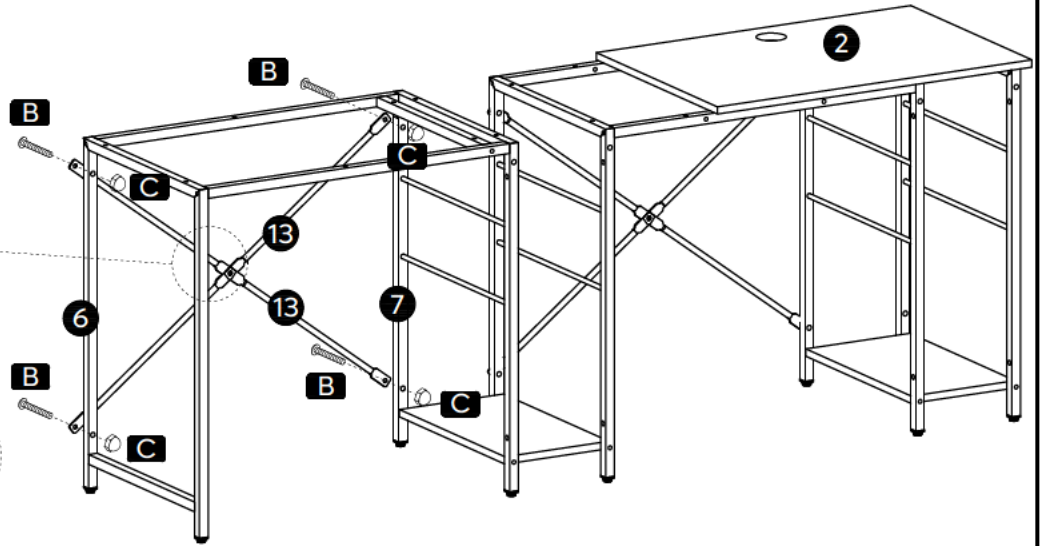
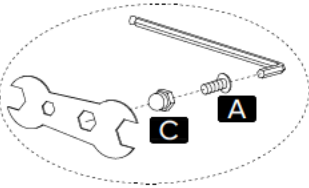
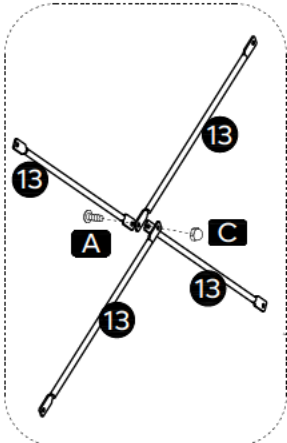

(C)

※This hole does not assemble screws, but only indicates the installation direction.  
 ※Ce trou n'est pas équipé de vis, mais indique seulement la direction d'installation.  
 ※Dieses Loch montiert keine Schrauben, sondern zeigt nur die Einbaurichtung an.  
 ※Questo foro non assembla viti, ma indica solo la direzione di installazione.  
 ※Este agujero no está equipado con tornillos, pero sólo indica la dirección de instalación.  
 ※この穴はネジを組み立てるのではなく、取り付け方向を示すだけです。  
 ※此孔不组装螺丝，仅指示安装方向。

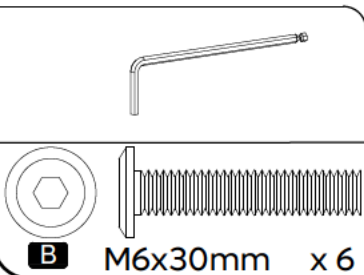
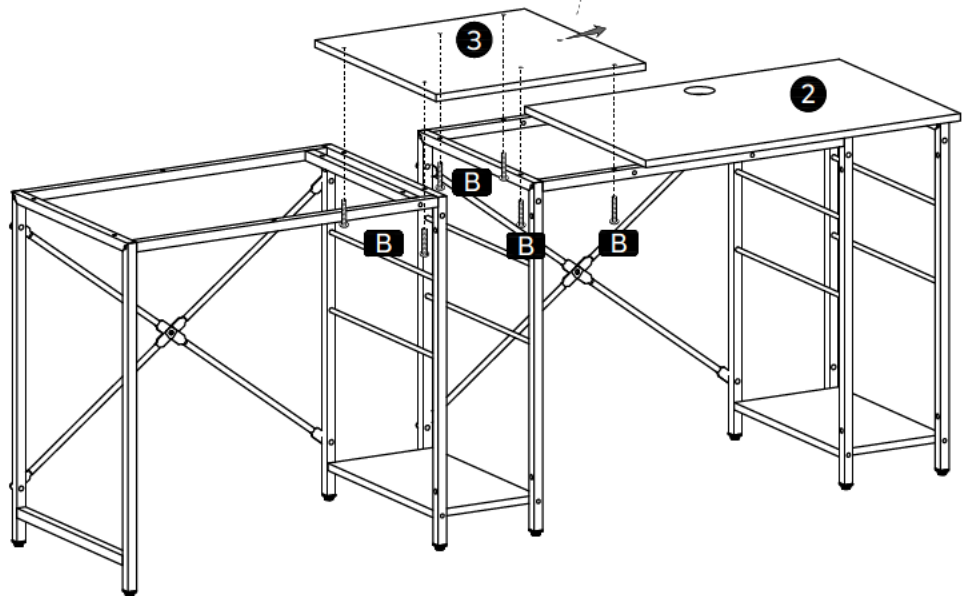

# 24

100% tighten  
 100 % serré  
 100% festziehen  
 Serraggio al 100%  
 100 % reforzado  
 100%締め付け  
 100%锁紧

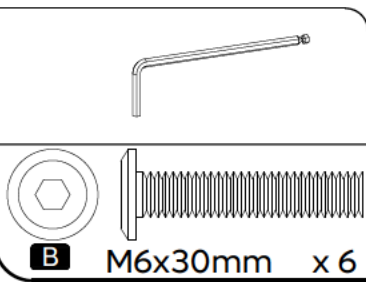
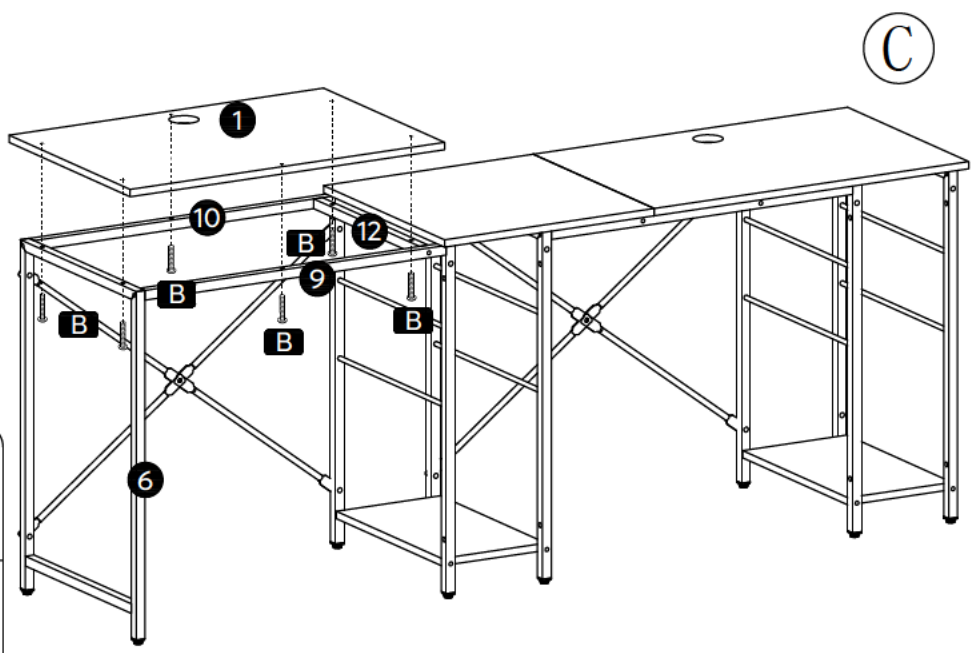

**B** M6x30mm x 6

(C)

# 25

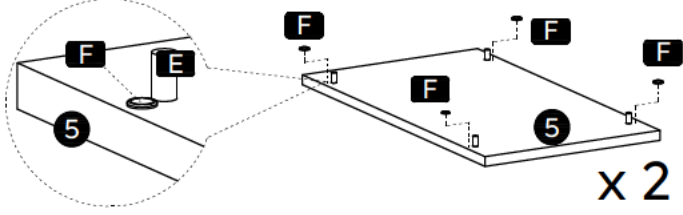

When the laminate is not flat, paste the F pad  
 Si le stratifié est incomplet, utilisez le tampon F  
 Wenn das Laminat uneben ist, verwenden Sie das F-Pad.  
 Quando il laminato è irregolare, incollare il pad F  
 Si el laminado es irregular, pegue la almohadilla F  
 ラミネートにむらがある場合、Fパッドを貼ってください  
 当层板不平整时，粘帖F配件

(C)

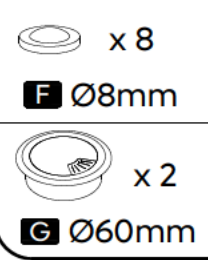
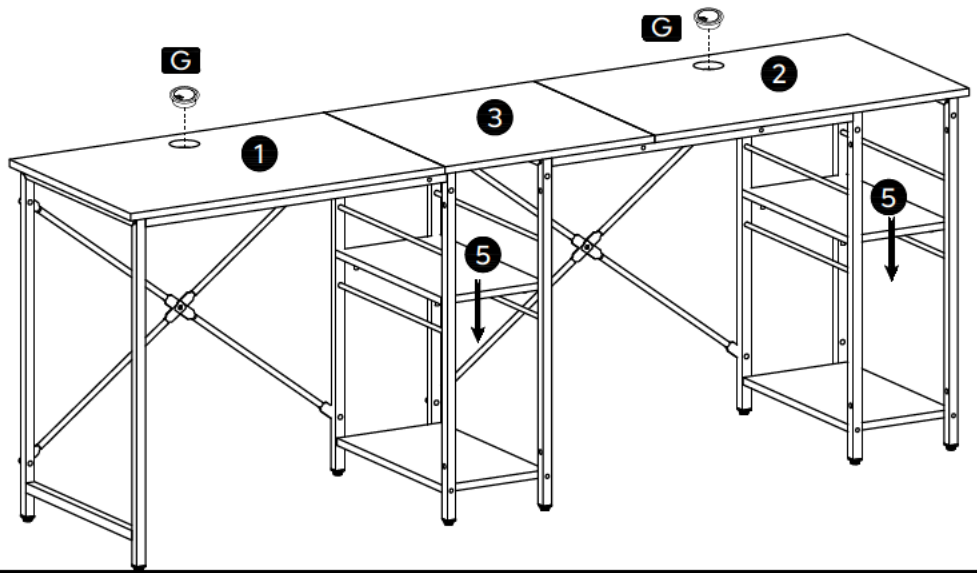

○ x 8  
**F** Ø8mm  
 ○ x 2  
**G** Ø60mm