

Assembly Instructions

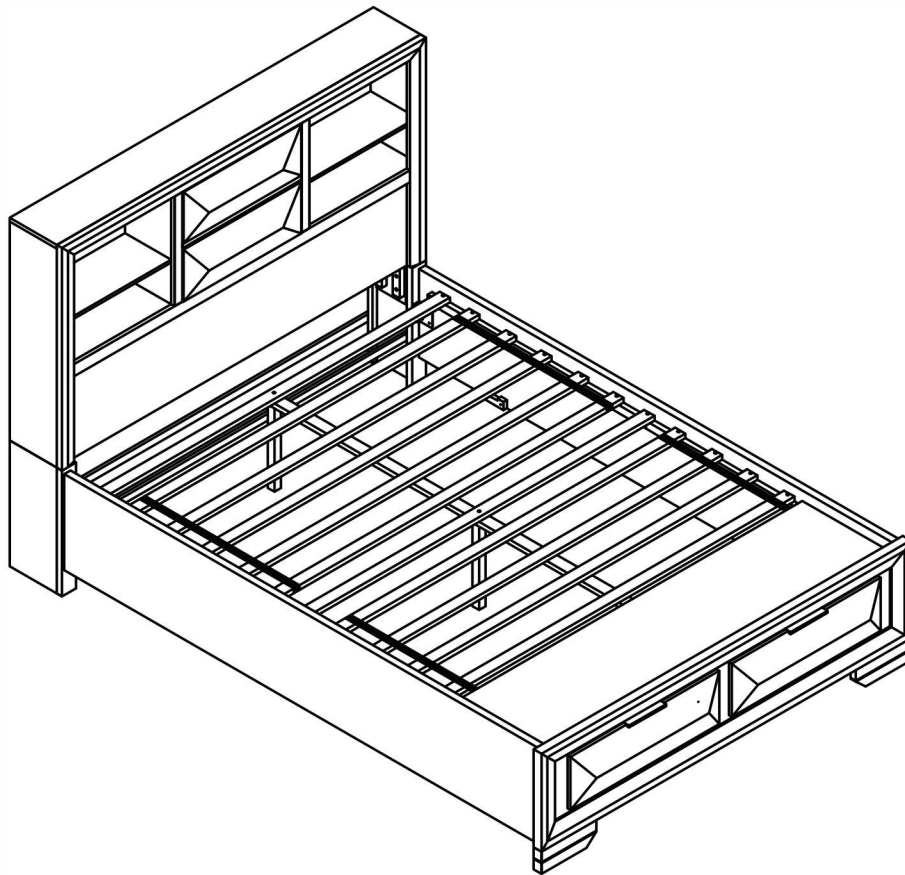

ASSEMBLY RATING

The Assembly Rating is a 5-point system that shows the degree of effort needed in assembling a specific product (with 1 being easy and 5 being difficult). For some products, two persons are recommended.

EASY  DIFFICULT

Tools Required For Assembly:

Allen Wrench

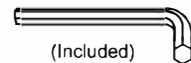

(Included)

Phillips Screwdriver



(Not Included)



2 PERSONS RECOMMENDED

ASSEMBLY & CARE ADVICE

FOR YOUR FURNITURE TO LAST, CORRECT ASSEMBLY AND PROPER MAINTENANCE ARE NECESSARY. PLEASE FOLLOW THE INFORMATION PROVIDED BELOW TO FULLY ENJOY YOUR FURNITURE.

BASIC ASSEMBLY TECHNIQUES

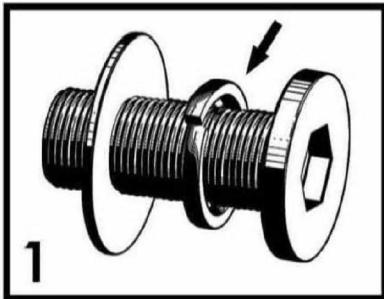

When lock or spring washer is used in an assembly, please make sure the lock or spring washer is placed between the larger flat washer and the head of the screw or bolt.



Position each part correctly and insert screws or bolts into their respective holes by hand tighten or using the proper hand tool. Only tighten when step is completed or when instructed to do so.

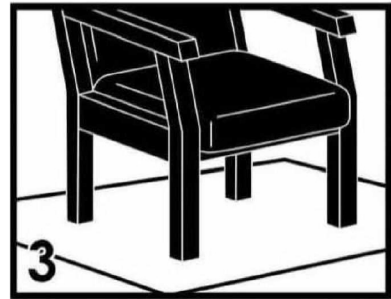

Use cardboard or carpet area when assembling furniture to prevent scratches. Make sure the furniture rests on a flat and level surface with each leg evenly touching the floor.

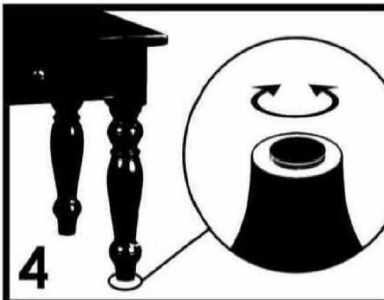

Some furniture comes with height adjustment knobs underneath each leg. To lower or to raise each leg, you need to turn clockwise or counterclockwise, respectively.

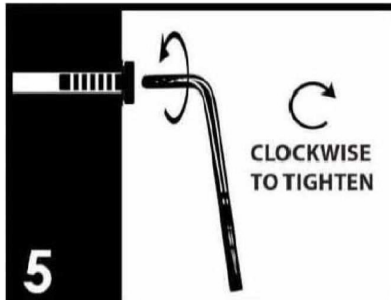

Make sure all parts are properly aligned, then use the appropriate hand tool to completely tighten the bolts or screws. Do not use power tools and do not over-tighten.

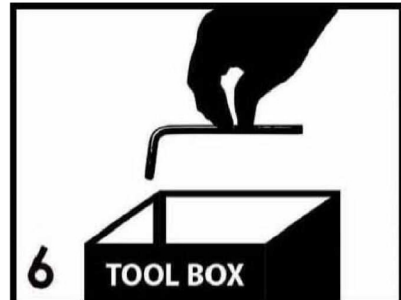

Save the instructions and store the Allen wrench or any supplied tool for later maintenance. After two weeks, check and tighten any loose hardware and repeat again every six months thereafter.

IT IS THE USER'S RESPONSIBILITY TO MAINTAIN THE FURNITURE. THE HARDWARE MAY LOOSEN OVER TIME AND MAY CAUSE THE FURNITURE TO BE WOBBLY AND UNABLE TO SUPPORT ITS INTENDED WEIGHT CAPACITY. THIS MAY LEAD TO COLLAPSE AND MAY CAUSE SERIOUS INJURY.



FAILURE TO FOLLOW THE GUIDELINES ABOVE MAY RESULT IN INJURY AND/OR PROPERTY DAMAGE.

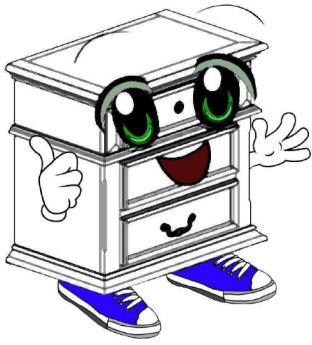

Before you begin, please read Page 2 of "Assembly and Care Advice".

And remember, do not tighten until each step is completed or instructed.

Parts List

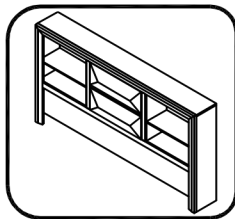

#1 x 1unit
Headboard Panel

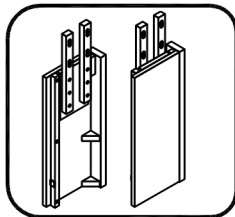

#2 x 2 units
Headboard Leg

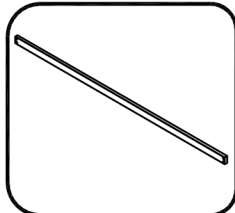

#3 x 2 units
Headboard Support Rail
Front / Back

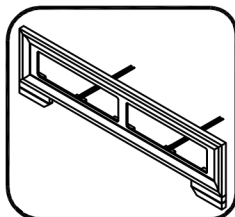

#4 x 1unit
Footboard

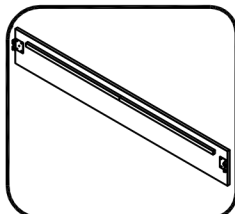

#5 x 2 units
Bed Rail

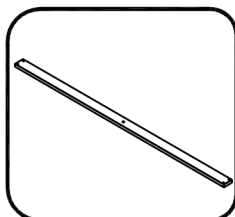

#6 x 1 unit
Drawer Slat

Hardware List

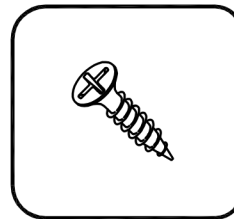

#A x 6 units
CSK M4 x 16mm

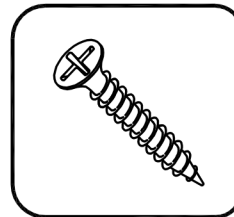

#B x 38 units
CSK M4 x 32mm

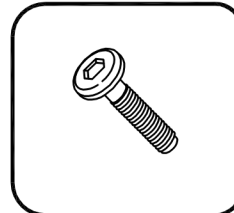

#C x 8 units
JCBC Screw M6 x 35mm



#D x 3 units
JCBC Screw M6 x 60mm

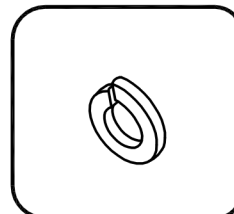

#E x 8 units
Spring Washer Ø1/4"

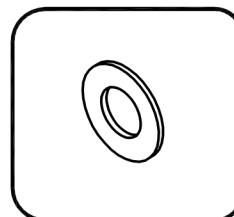

#F x 8 units
Flat Washer Ø1/4" x 20mm

Parts List

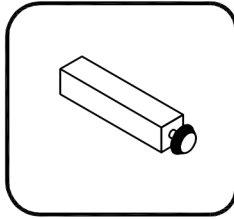

#7 x 1 unit
Drawer Slat Support

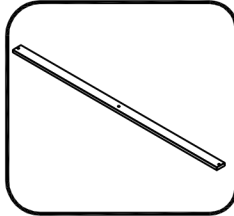

#8 x 3 units
Bed Slat 3 Holes

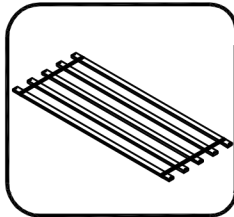

#9 x 10 units
Bed Slat 2 Holes

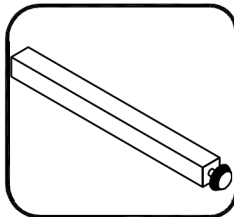

#10 x 3 units
Bed Slat Support

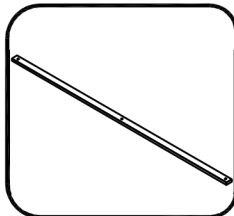

#11 x 1 unit
Center Slat With 3 Holes

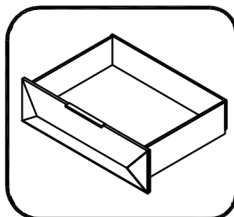

#12 x 2 units
Drawer

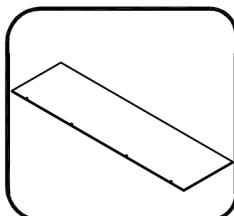

#13 x 1 unit
Slat Cover

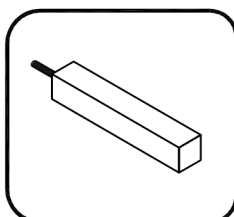

#14 x 1 unit
Drawer Slat Support
Stopper

Hardware List

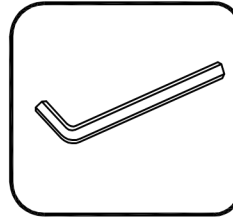

#G x 1 unit
L Key M4

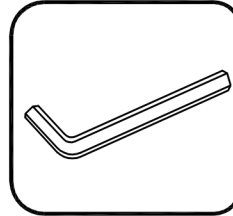

#H x 1 unit
L Key M5



1) Prepare 8 bolts assembly by inserting lock washer (#E), then flat washer (#F) onto bolts (#C). Align HB legs (#2) to the holes of the HB panel (#1). Secure with bolts (#C).

2) Align HB support rail (#3) to the HB legs (#2). Make sure it is rested on the wood cleat. Secure with screws (#B). There are no pre-drilled holes.

#B x 8 pcs
#C x 8 pcs
#E x 8 pcs
#F x 8 pcs

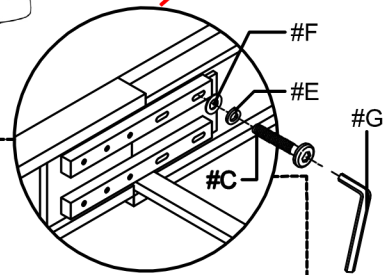

STEP 1.1

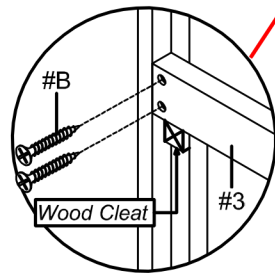

STEP 1.2

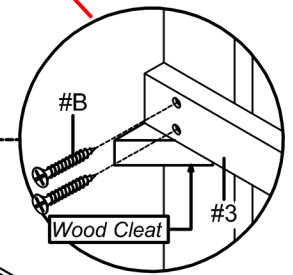

STEP 1.3

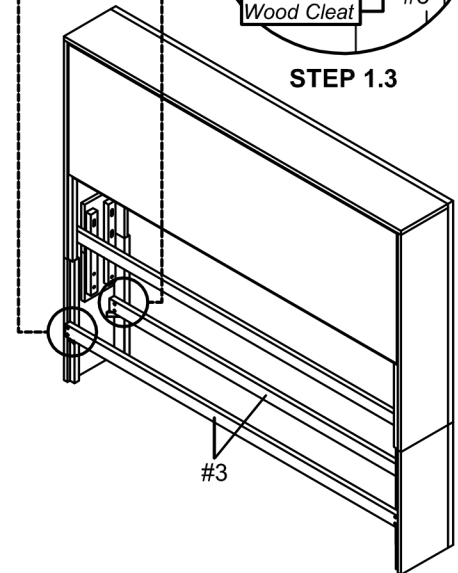
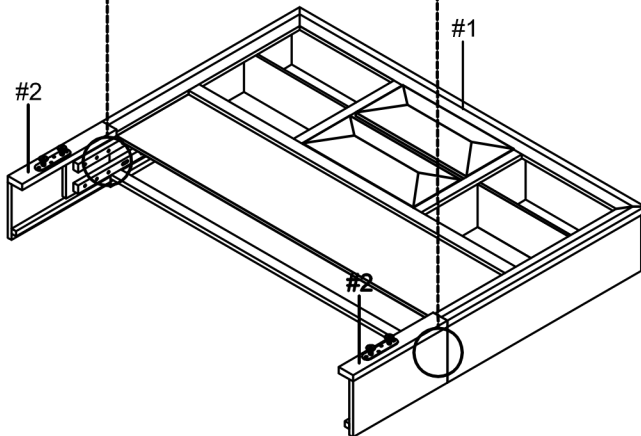

1) Hook the bed rails (#5) to the bolts of the HB legs. Secure the bolts by using an Allen wrench (#H).

#B x 4 pcs

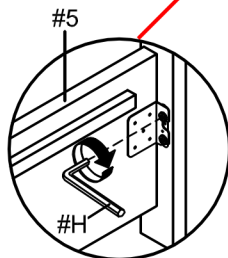

STEP 2.2

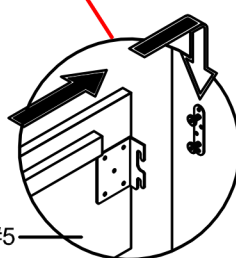

STEP 2.1

2) Insert slat support stopper (#14) bolt through the hole of drawer slat (#6). Secure by attaching drawer slat support (#7) to the slat support stopper (#14).

4) Turn FB (#4) T Runner so that it rests on drawer slat (#6).

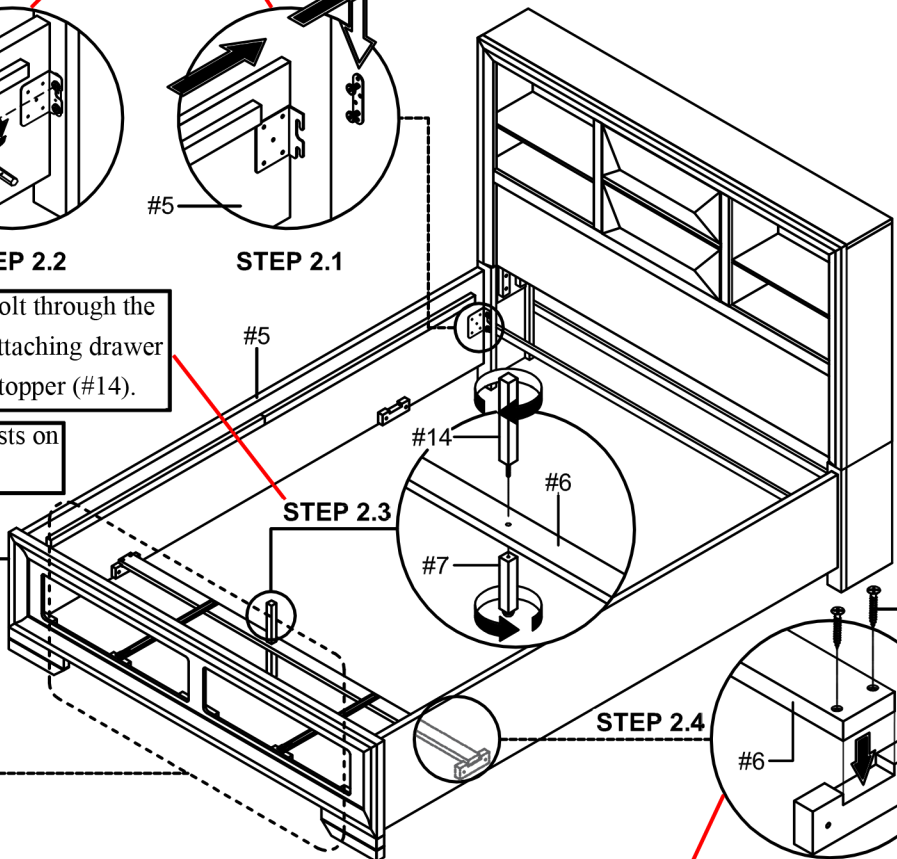

STEP 2.3

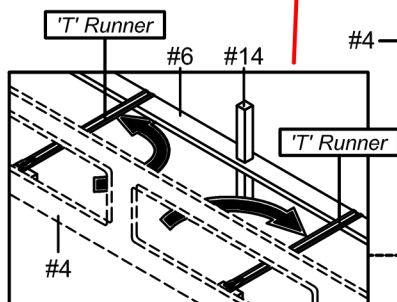

STEP 2.5

STEP 2.4

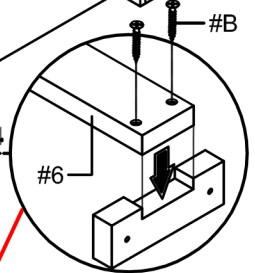

3) Align drawer slat (#6) to the side rails (#5), then secure with screws (#B).



#3

#A x 2 pcs

Secure the T Runner with screws (#A) onto drawer slat (#6), then insert drawers (#12) through the T Runner. Make sure adjust the leveler of the drawer slat support (#7) according to ground level.

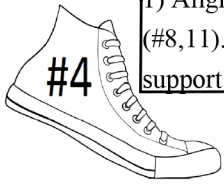
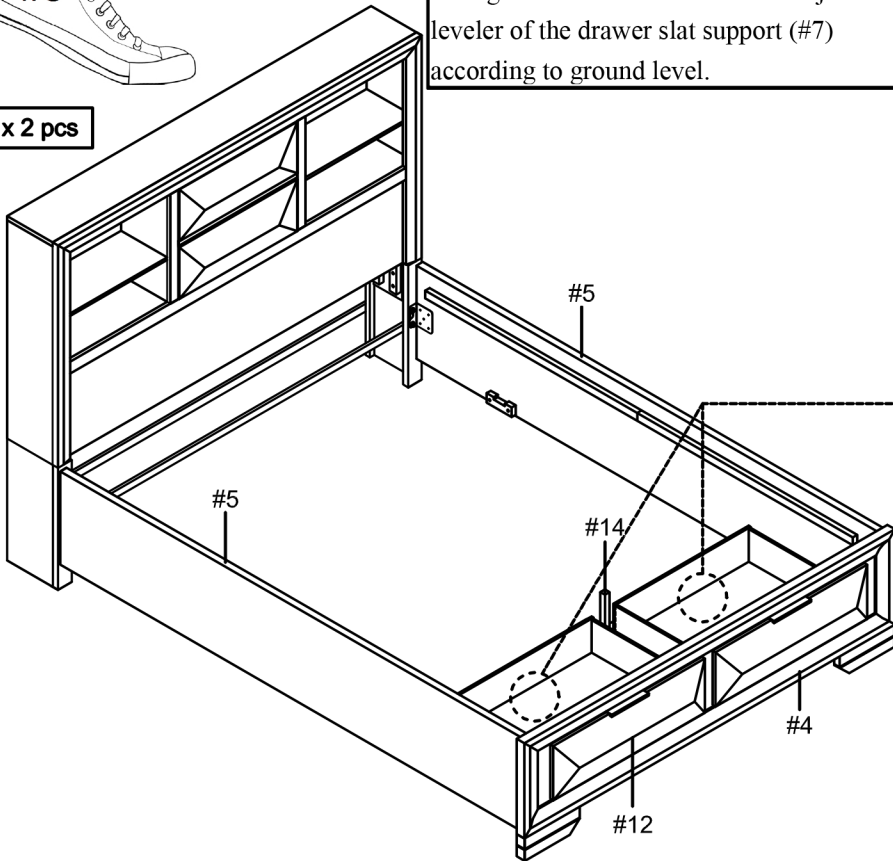
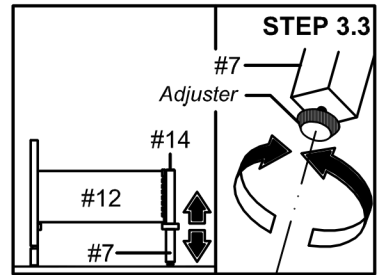
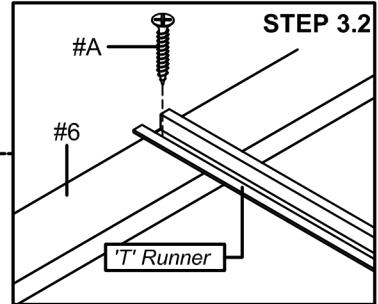
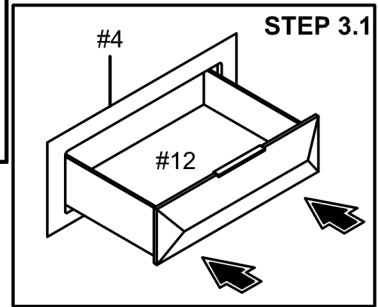

#4

#B x 26 pcs
#D x 3 pcs

1) Align slats (#8) to the holes of the center slats (#11), then align slat support (#10) to the holes of the slats (#8,11). Secure with bolts (#D). Make sure slats (#8,11) are 90 degrees from each other and adjust leveler on slat support (#10) according to ground level.

2) Align bed slats (#9) in-between slats (#8), then secure all slats (#8,9) with screws (#B).

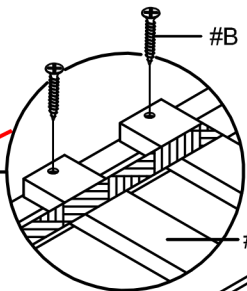

STEP 4.2

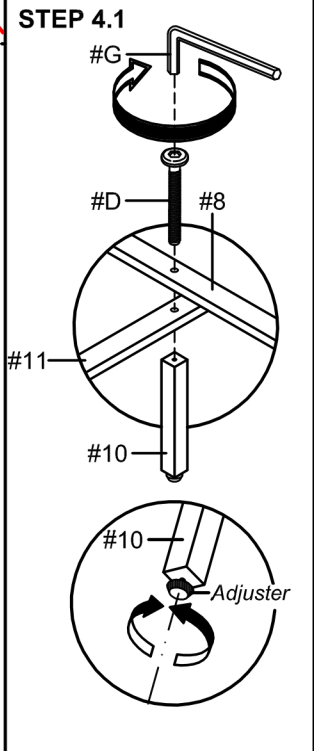
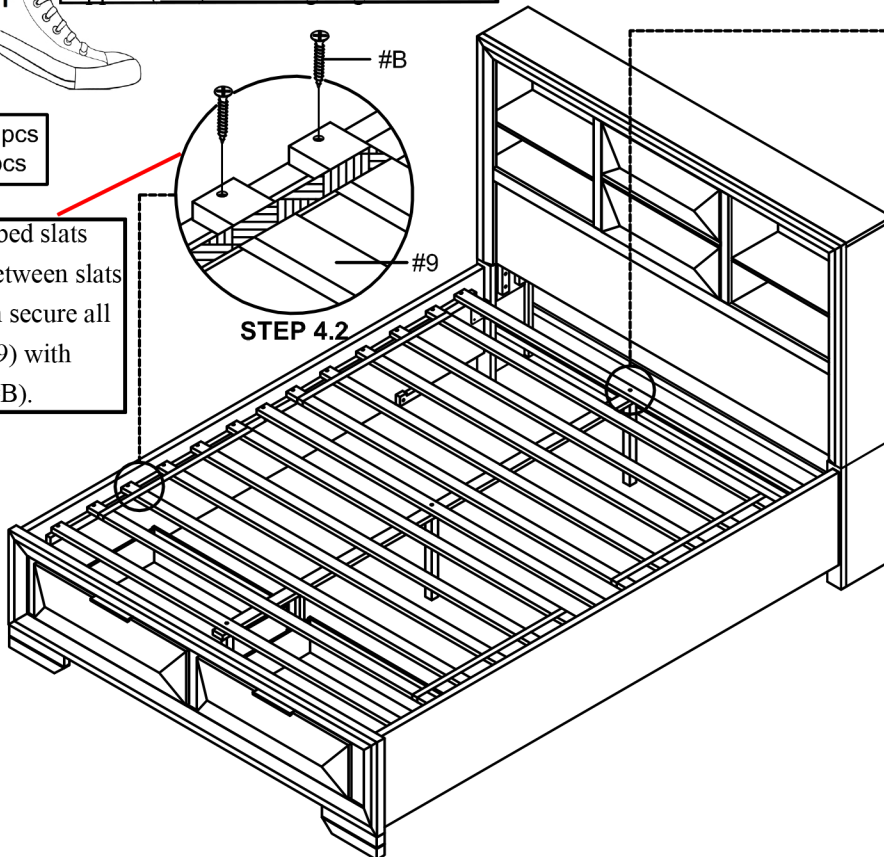

Align slat cover (#13) to the footboard, then secure with screws (#A).



#A x 4 pcs

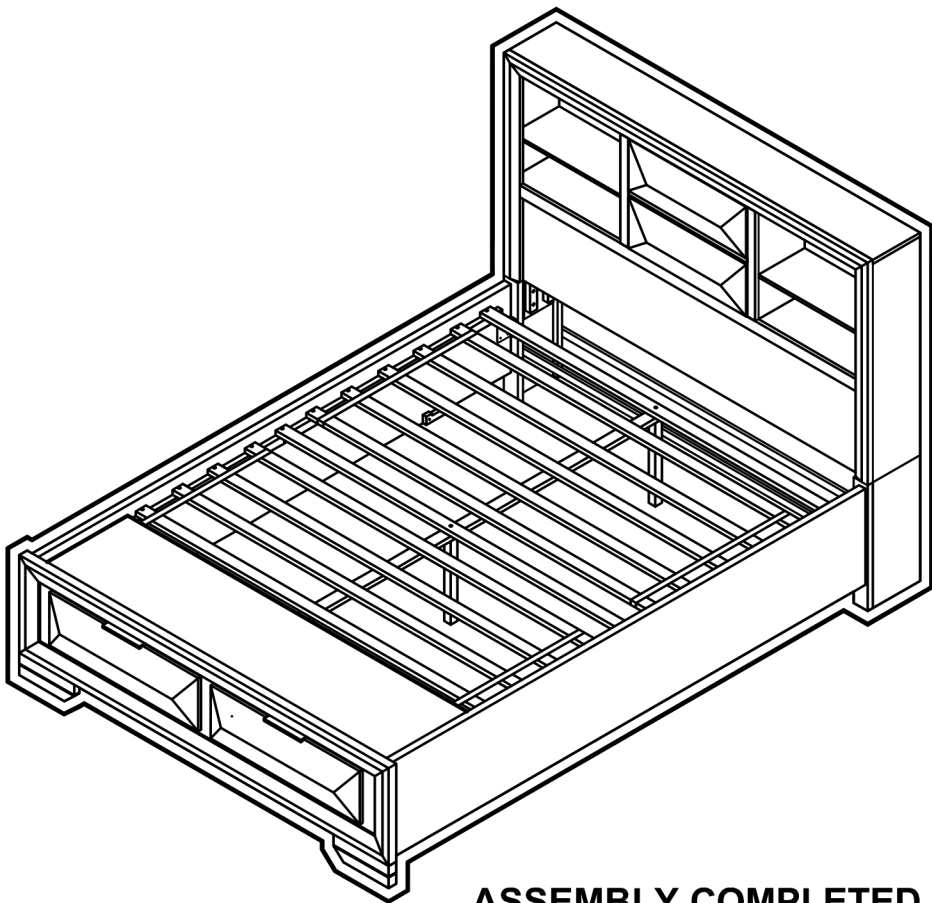
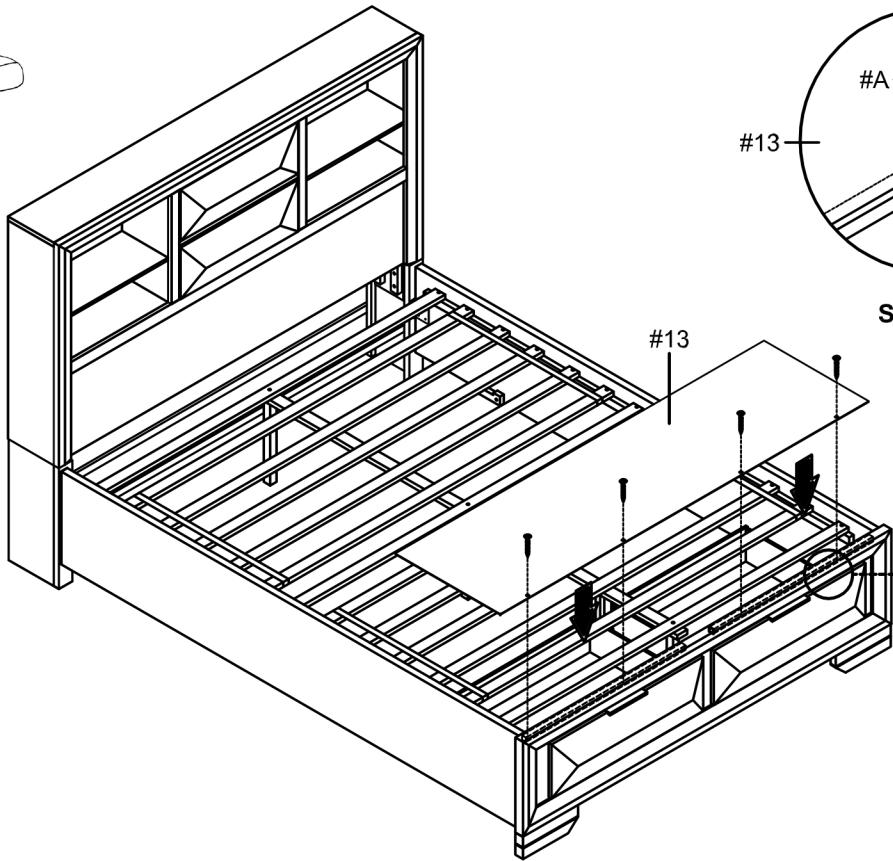

ASSEMBLY COMPLETED