

## ASSEMBLING & INSTALLATION INSTRUCTIONS

The drawing shown may not exactly match the product enclosed. However, the installation instructions do apply to this product.

- ◆ **WARNING! SHUT POWER OFF AT FUSE OR CIRCUIT BREAKER.**
- ◆ **ATTENTION! COUPER LE COURANT AU FUSIBLE OU UN DISJONCTEUR.**

### ASSEMBLING THE FIXTURE (Fig.1)

1. Shut off the power at the circuit breaker box. Remove old fixture and all hardware from Junction Box.
2. Carefully unpack your new fixture and lay out all the parts on a clear area. Take care not to lose any small parts necessary for installation.
3. Thread the two mounting screws into the pre-drilled holes in the Mounting plate spaced the same distance apart as the holes in the lamp body's canopy.
4. Attach the Mounting plate to the Junction Box with the two Junction Box Screws as shown. The side of the Mounting plate marked "GND" must face out. **The junction box is not included.**
5. While holding the lamp body(A) towards the ceiling, connect the electrical wires as Shown in Fig.2, making sure that all wire nuts are secured. You may have to wrap the connections with electrical tape. If your outlet has a ground wire (green or bare copper), connect the fixture ground wire to it. Otherwise connect fixture's ground wire directly to the Mounting strap with the green screw provided. After wires are connected, tuck them carefully inside the Junction Box.
6. Attach the canopy to the junction box, aligning screws on mounting plate with mounting holes in canopy and lock it securely with the ball nuts(B).
7. Install the light bulb(Not included) in accordance with the fixture's specifications. **NOTE: DO NOT EXCEED THE SPECIFIED WATTAGE!**

**Your installation is now complete. Return power to the junction box and test the fixture.**

FIG.1

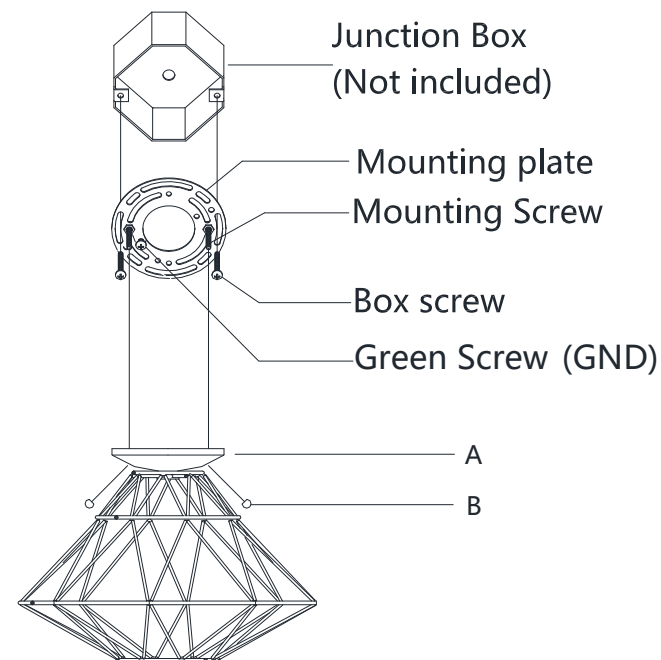

FIG.2

