

NOTICE BEFORE ASSEMBLY

Please choose the CHAISE to be on the LEFT or RIGHT hand side

Assembly Instruction I :CHAISE ON THE LEFT
ITEM NO. F6414,F6415,F6416

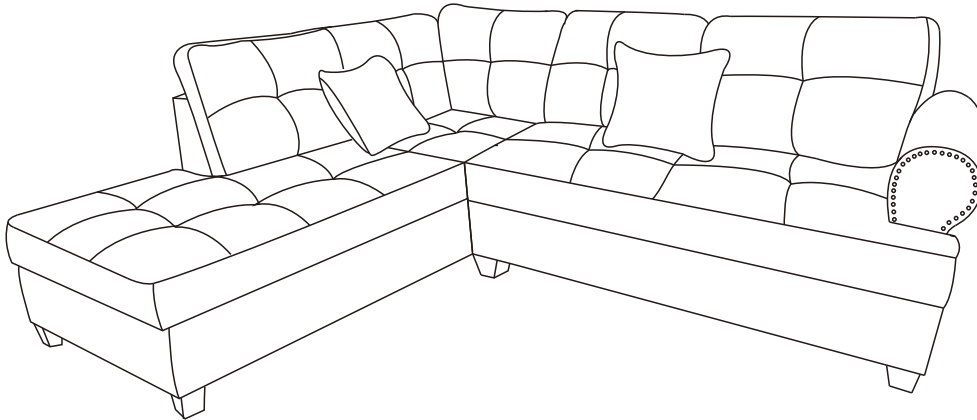

PARTS LIST

BOX 1		BOX 2	
*Cushions, pillow and legs included		*Cushions, pillow and legs included	
1. x11	2. x11	3. x11	
4. x11	5. x2	6. x8	

BEFORE ASSEMBLY

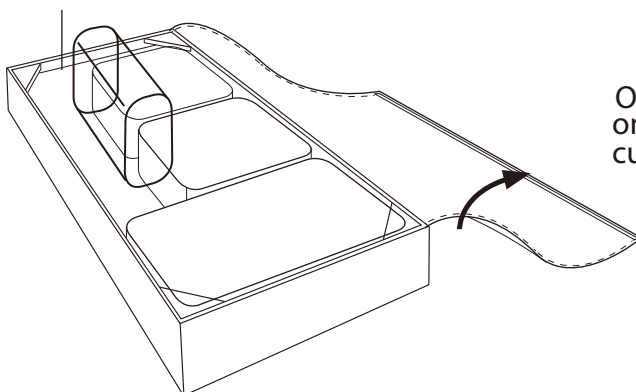

Open up the Velcro of Non-Woven Fabric cover on the bottom of the seat frame to remove seat cushions, back cushions and pillow

*****PLEASE REMOVE ALL PARTS FROM SEAT FRAMES AND SEAT BACKS BEFORE ASSEMBLY*****

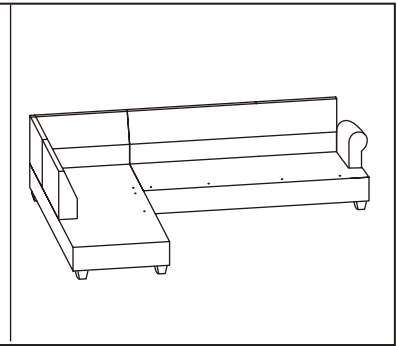
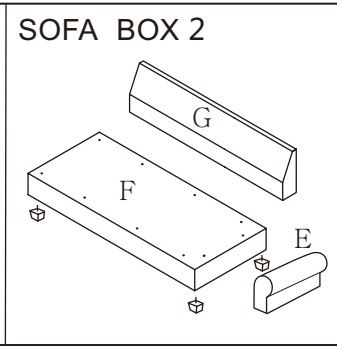
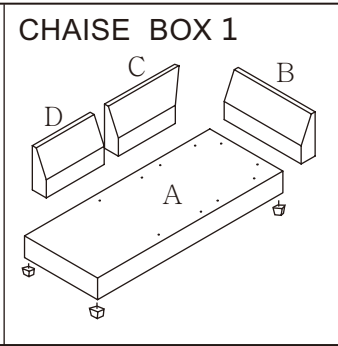
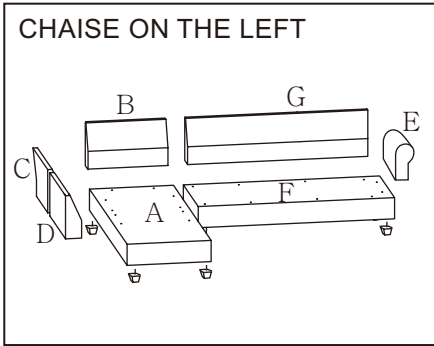

CHAISE ASSEMBLY INSTRUCTION BOX 1

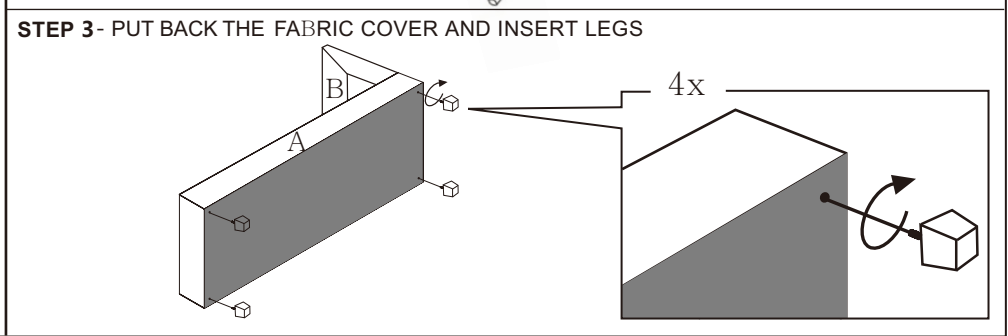
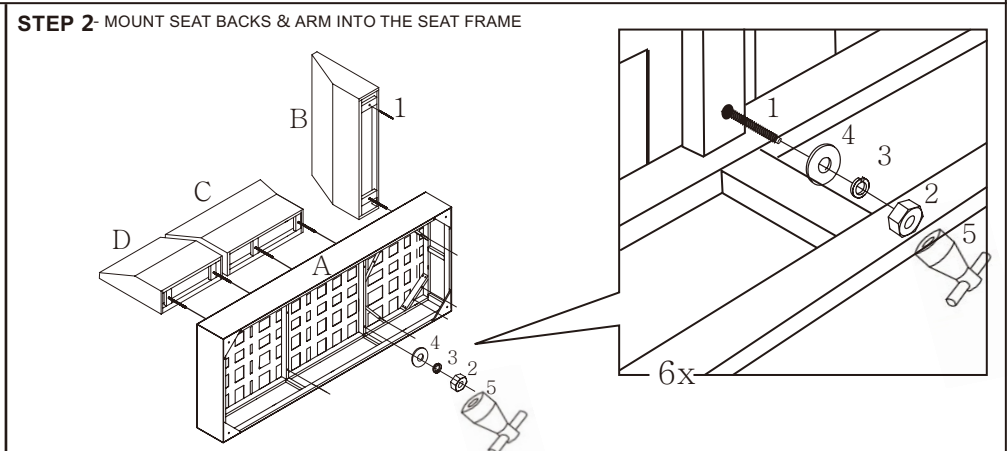
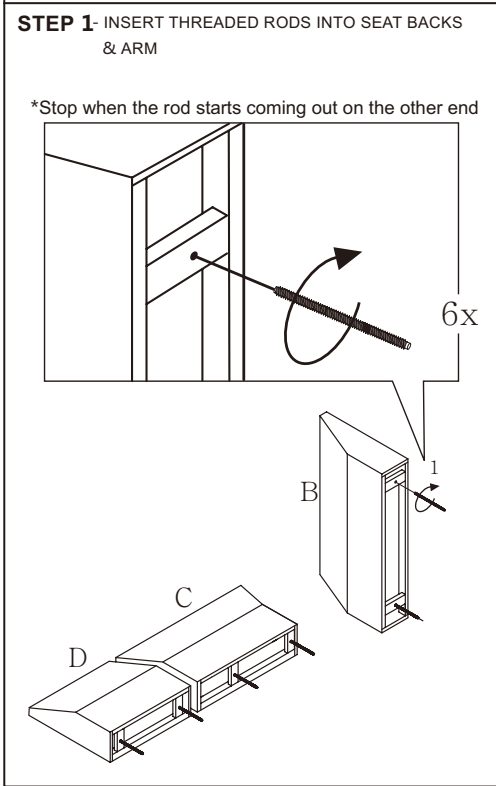

SOFA ASSEMBLY INSTRUCTION BOX 2

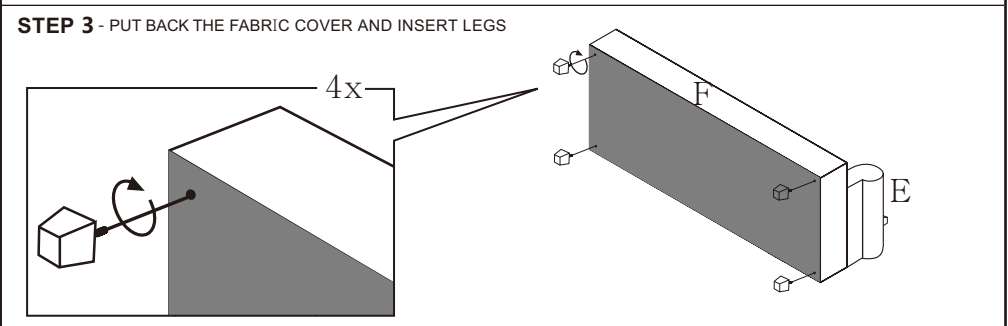
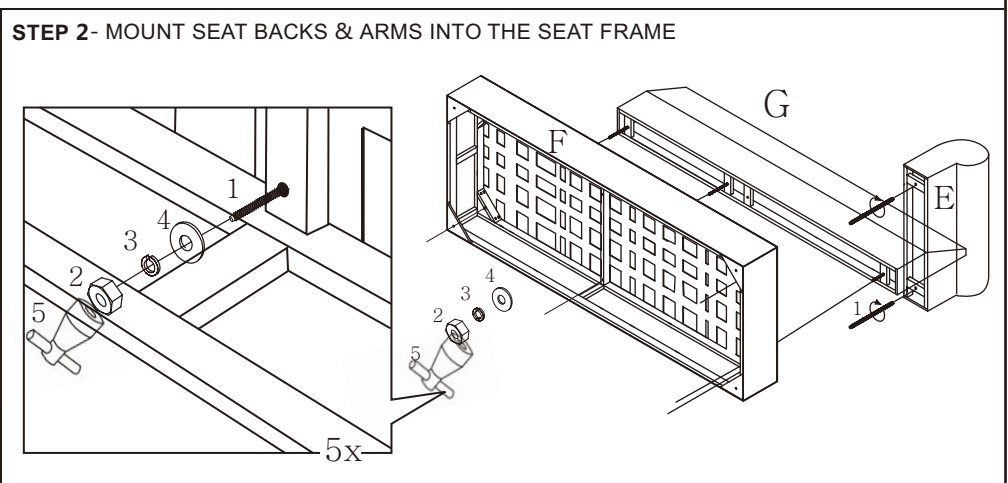
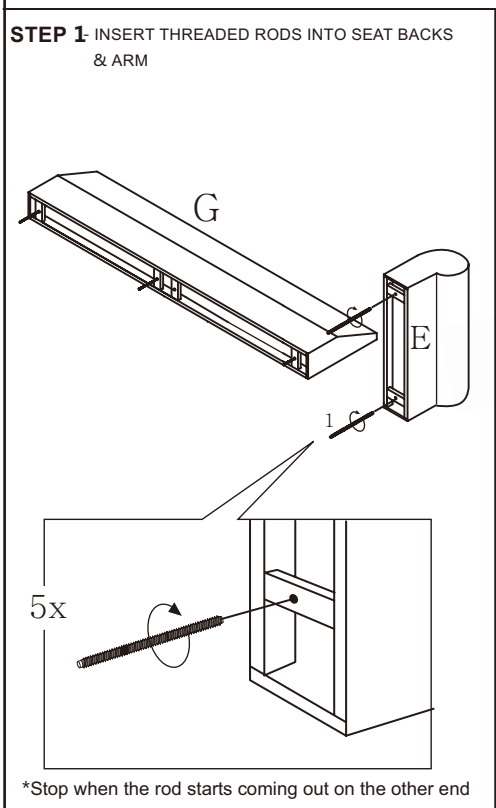

NOTICE BEFORE ASSEMBLY

Please choose the CHAISE to be on the LEFT or RIGHT hand side

Assembly Instruction II:CHAISE ON THE RIGHT

ITEM NO. F6414,F6415,F6416

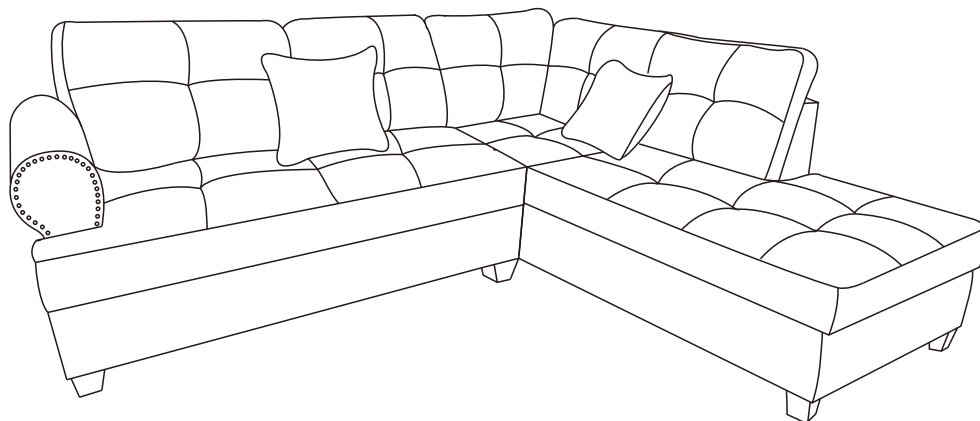

PARTS LIST

BOX1

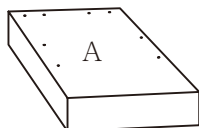

*Cushions, pillow and legs included

BOX2



*Cushions, pillow and legs included

1.  x11

2.  x11

3.  x11

4.  x11

5.  x2

6.  x8

BEFORE ASSEMBLY

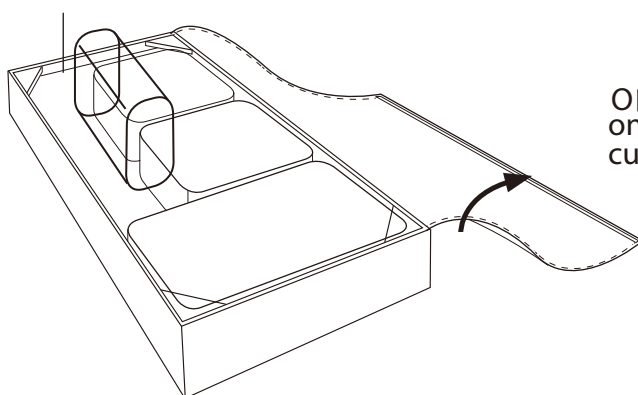

Open up the Velcro of Non-Woven Fabric cover on the bottom of the seat frame to remove seat cushions, back cushions and pillow

*****PLEASE REMOVE ALL PARTS FROM SEAT FRAMES AND SEAT BACKS BEFORE ASSEMBLY*****

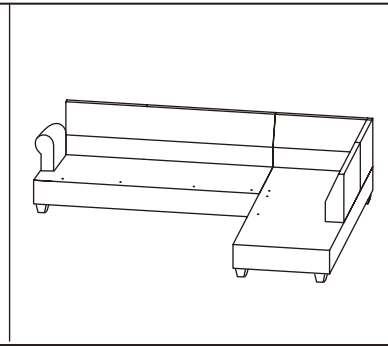
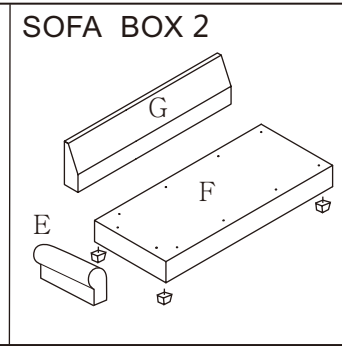
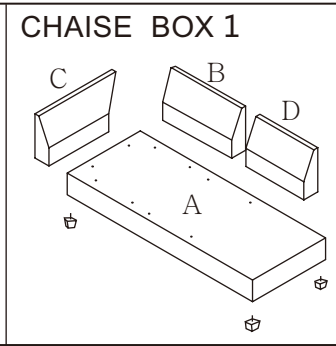
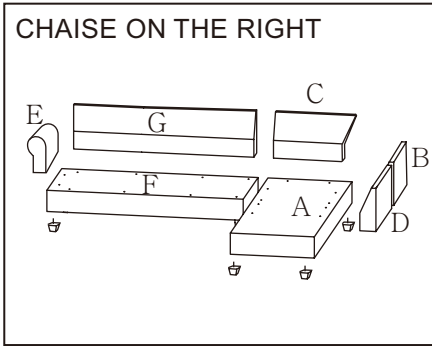

CHAISE ASSEMBLY INSTRUCTION BOX 1

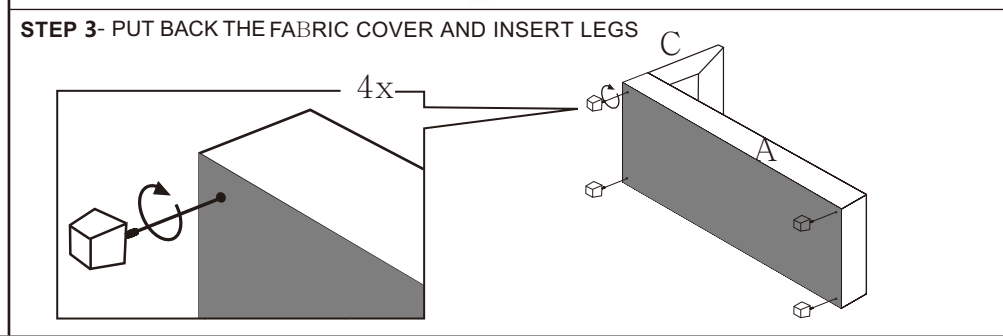
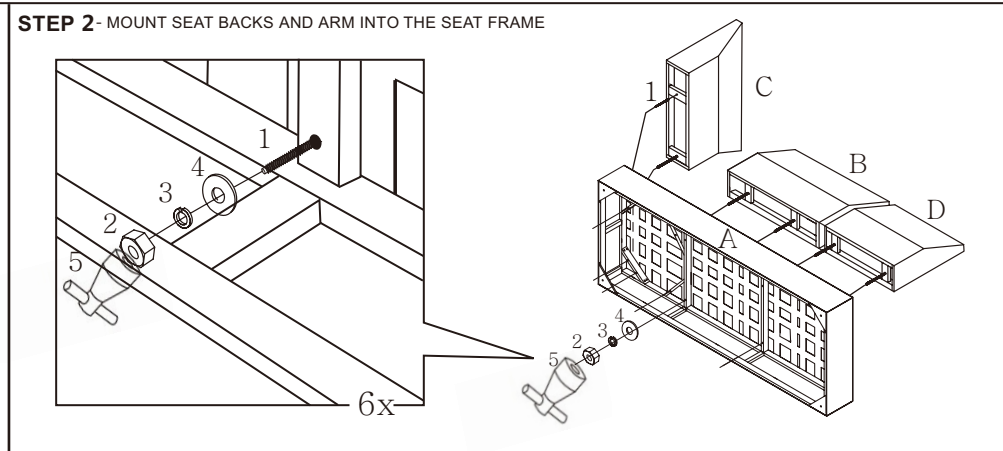
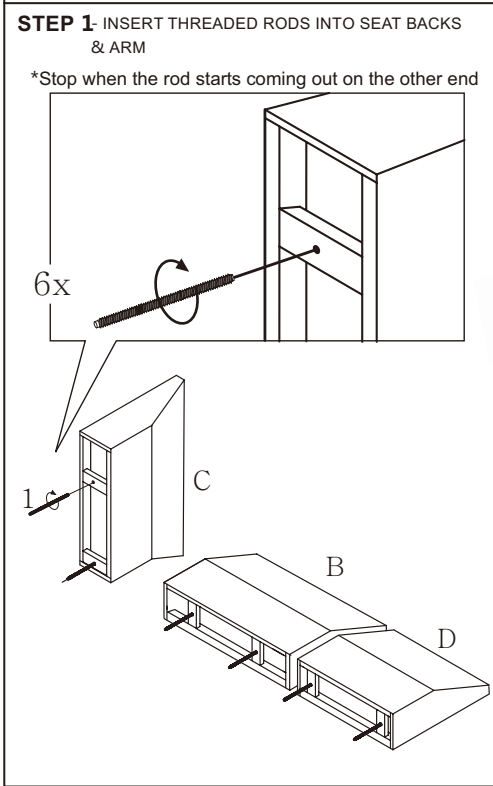

SOFA ASSEMBLY INSTRUCTION BOX 2

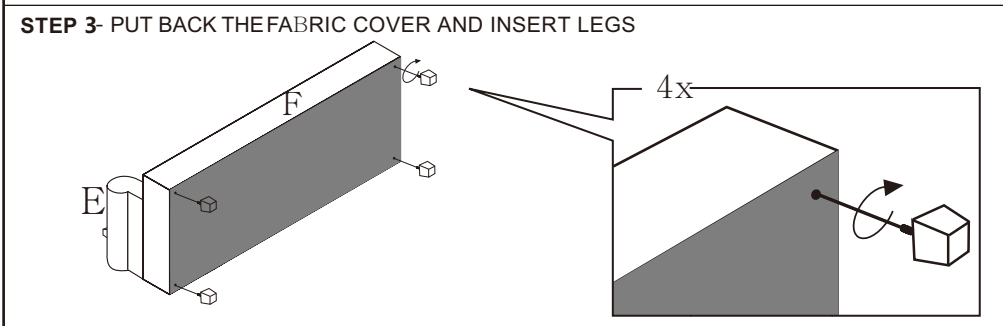
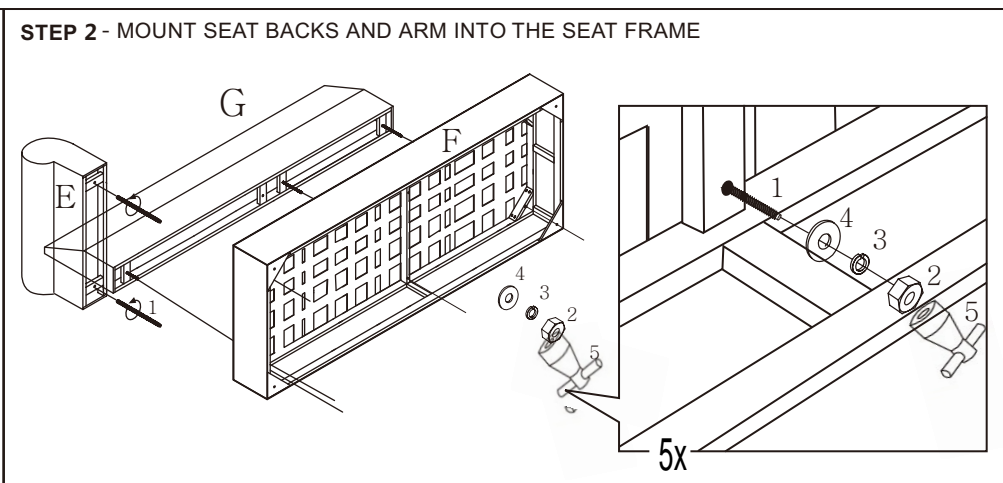
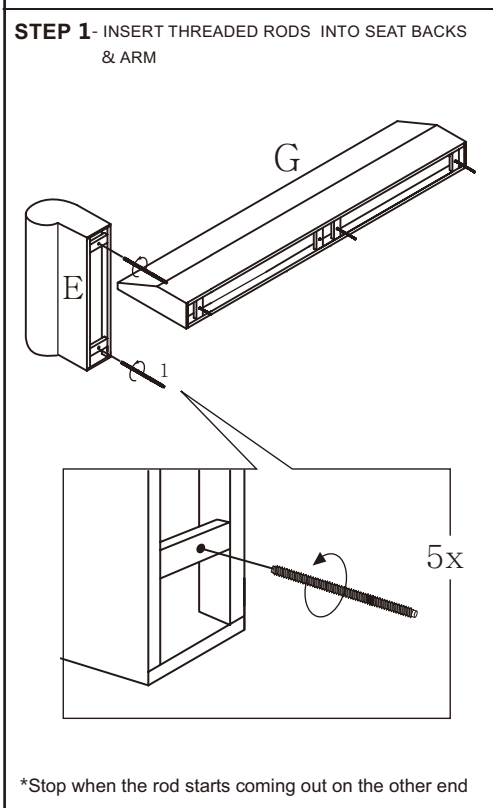

Assembly Instructions

ITEM NO.: F6414,F6415,F6416

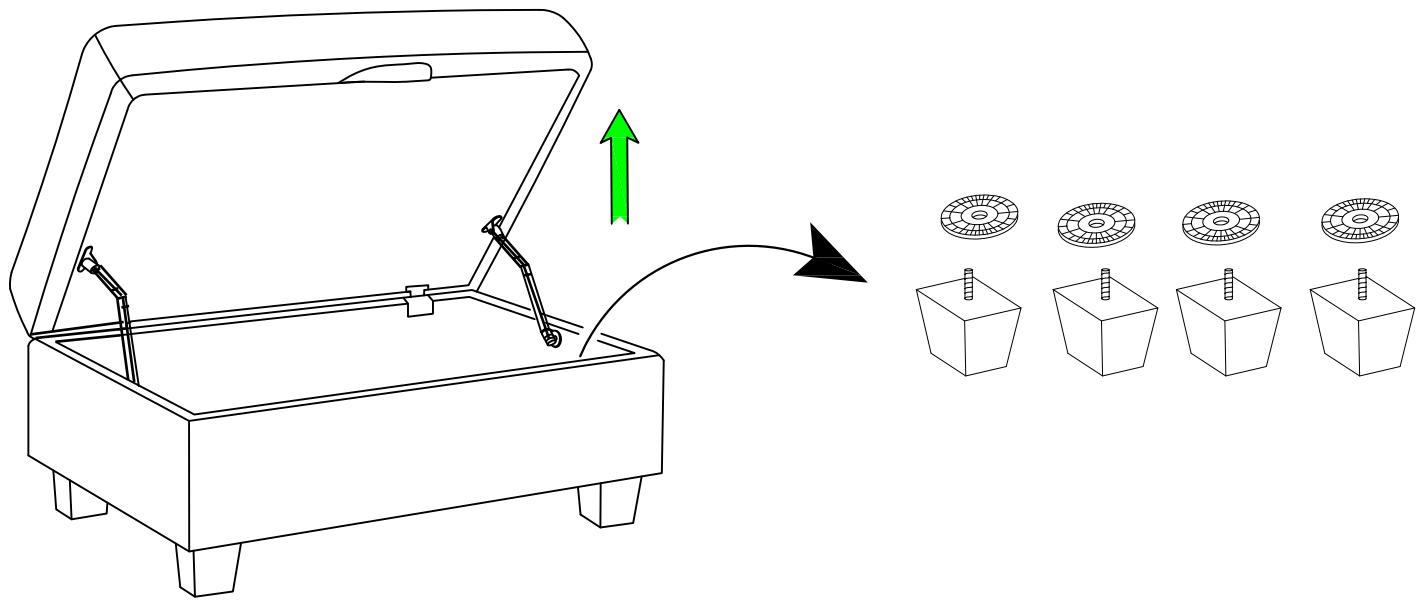

1

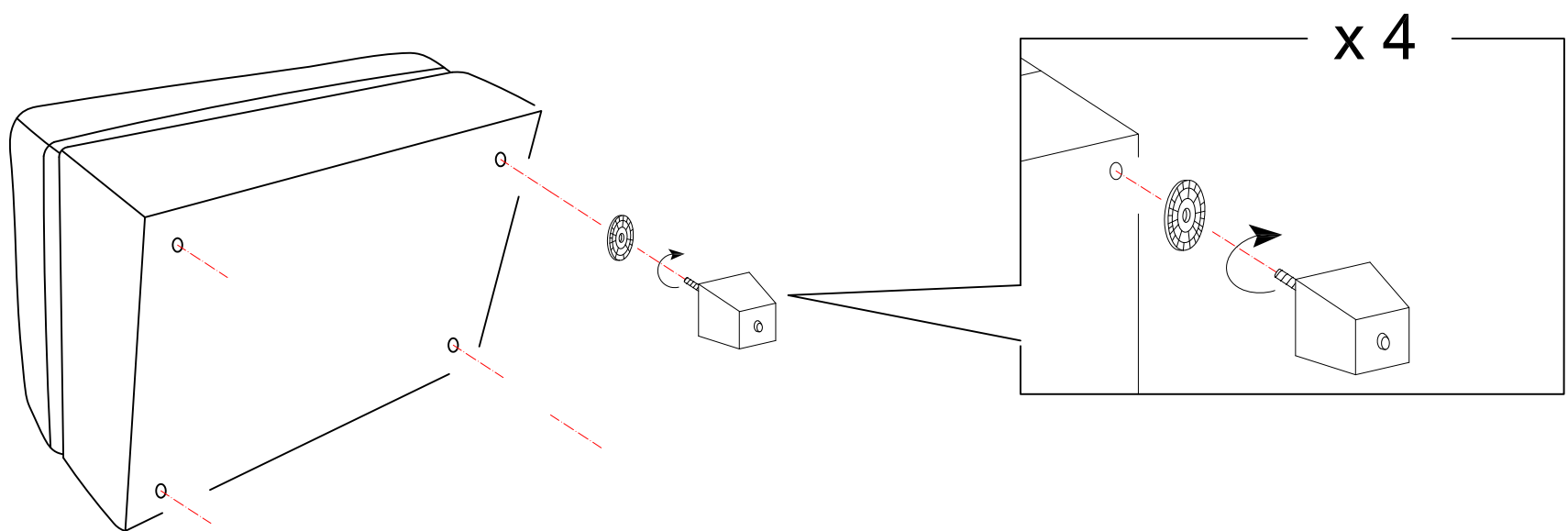

2

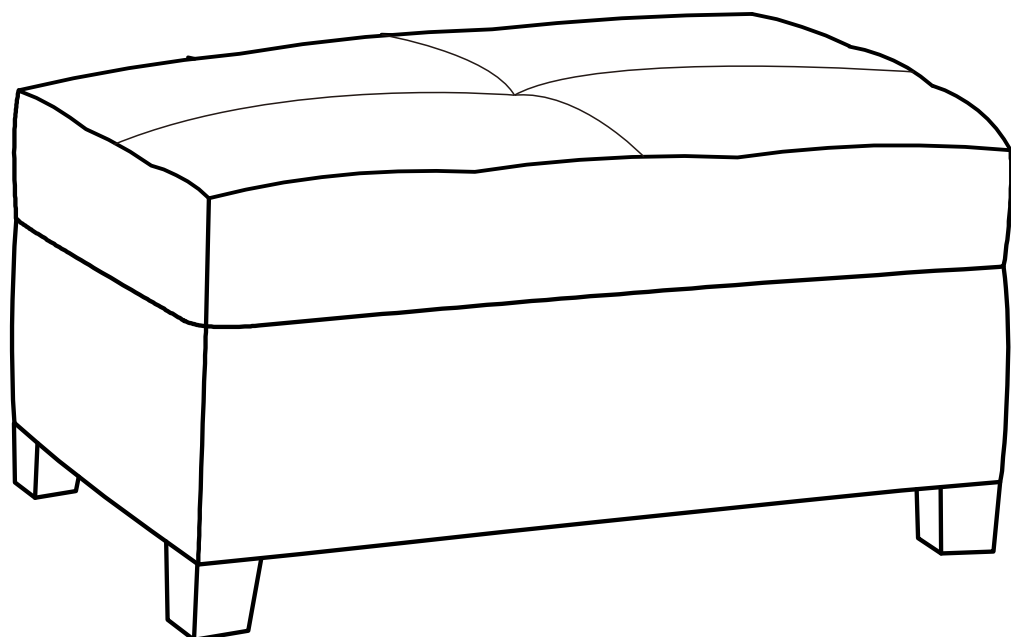

3

INSERT THE “n” SHAPE HANGER INTO THE SEAT FRAME TO ATTACH THE SECTIONAL TOGETHER.

