

# Parts List For Dexter

## BED CARTON

- (10) HEADBOARD PANEL
- (11) FOOTBOARD PANEL

PART #351501 HARDWARE BAG FOR BED ATTACHMENT TO FRAME

- (1) 1/4-20 2 1/4" COUNTER SUNK ALLEN HEAD SCREW-4
- (2) 1/4-20 1" FLAT ALLEN HEAD SCREW-4
- (3) 1/4-20 HEX NUT-4
- (4) 5/8" OD FLAT WASHER-8
- (5) ALLEN WRENCH
- (6) PLASTIC GLIDE-4
- (7) FINIAL-4
- (8) FOOT CASTING-2
- (9) LEG EXTENSION-2

## HEADBOARD CARTON

- (10) HEADBOARD PANEL

PART #351502 HARDWARE BAG FOR HEADBOARD ATTACHMENT TO FRAME

- (1) 1/4-20 2 1/4" COUNTER SUNK ALLEN HEAD SCREW-4
- (3) 1/4-20 HEX NUT-4
- (4) 5/8" OD FLAT WASHER-4
- (5) ALLEN WRENCH
- (6) PLASTIC GLIDE-2
- (7) FINIAL-4
- (9) LEG EXTENSION-2

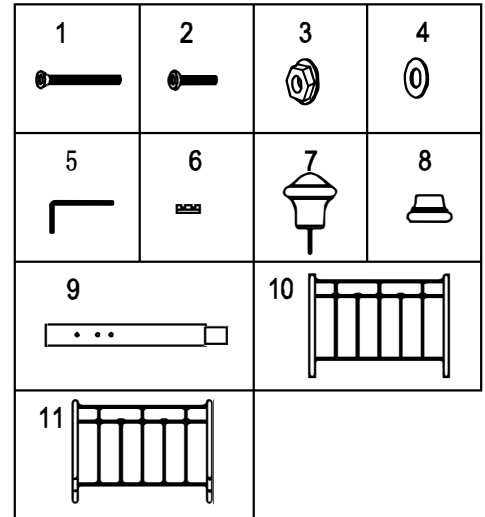

## PRODUCT FULLY ASSEMBLED

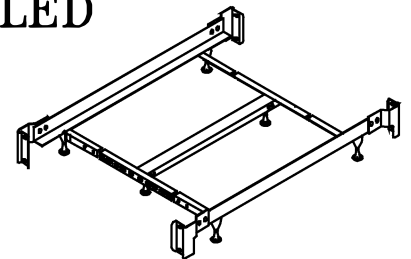
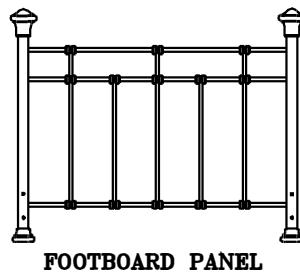
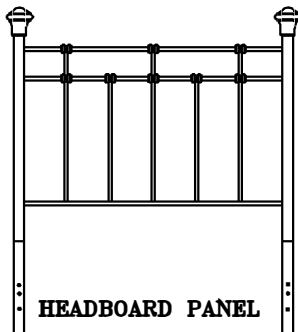

QUEEN - KING BED FRAME FULLY ASSEMBLED  
NOTE: SEE INSTRUCTIONS INCLUDED IN FRAME CARTON FOR FRAME ASSEMBLY

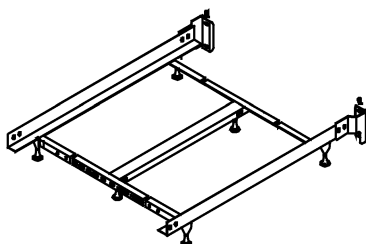

QUEEN - KING HEADBOARD ONLY FRAME FULLY ASSEMBLED  
NOTE: SEE INSTRUCTIONS INCLUDED IN FRAME CARTON FOR FRAME ASSEMBLY

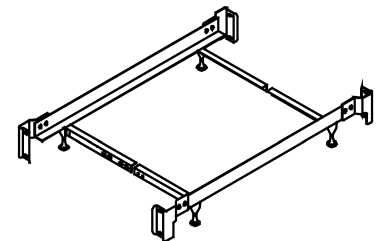

TWIN - FULL BED FRAME FULLY ASSEMBLED  
NOTE: SEE INSTRUCTIONS INCLUDED IN FRAME CARTON FOR FRAME ASSEMBLY

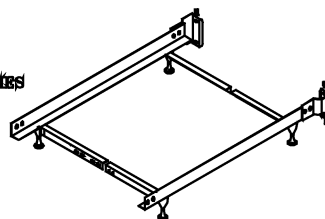

TWIN - FULL HEADBOARD ONLY FRAME FULLY ASSEMBLED  
NOTE: SEE INSTRUCTIONS INCLUDED IN FRAME CARTON FOR FRAME ASSEMBLY

# Instruction Sheet

SAVE ALL PACKAGING MATERIALS UNTIL PRODUCT IS FULLY ASSEMBLED. HARDWARE AND SMALL PIECES MAY NOT BE SEEN AND BE ACCIDENTALLY DISCARDED WITH PACKAGING MATERIALS.

FIGURE 1

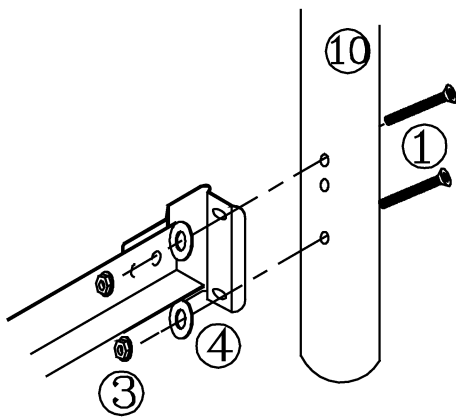
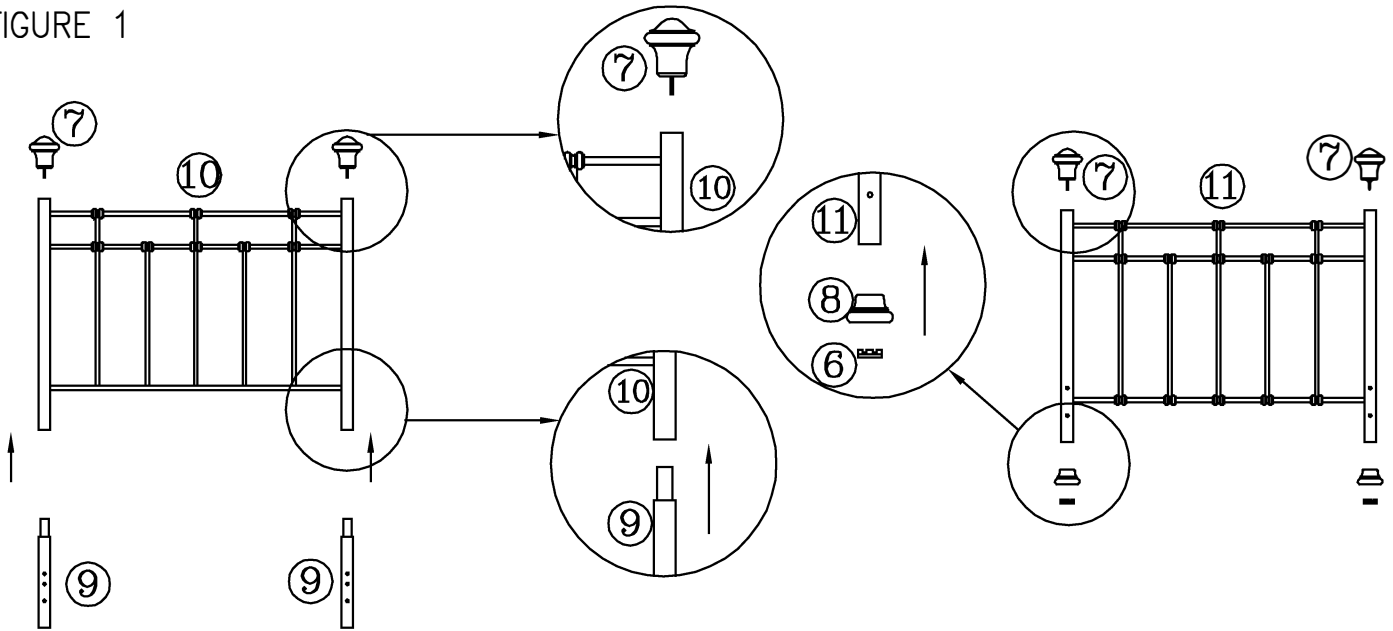

FIGURE 2

## Step 1

- Align top reduction of extension legs (9) with bottom of headboard posts. (See Figure 1) Make sure the 3 holes on extension legs are perpendicular to headboard panel.
- Now carefully insert extension legs (9) into bottom of headboard (10) posts.
- Screw in finials (7) on top of headboard (10) and footboard (11) posts. (See Figure 1)
- Slide foot castings (8) onto bottom of footboard (11) posts. Insert plastic glide (6) into bottom of foot casting.

## Step 2

- Place headboard and frame in desired location in room.
- Place 2 screws (1) through holes located in leg (9). (See Figure 2)
- Align bed frame bracket over screws.
- Place a flat washer (4) and a nut (3) on each screw. Hand-tighten, DO NOT TIGHTEN screws all the way.
- Repeat on other side of headboard.
- Tighten all screws securely using the Allen wrench (5).

## Step 3

- Position footboard panel (11) and align holes in the post with holes in the frame bracket. (See figure 3)
- Place flat washer (4) on each screw (2). Insert through bracket and into post. Hand-tighten, DO NOT TIGHTEN screws all the way.
- Repeat on other side of footboard panel.
- Tighten all screws securely using the Allen wrench (5).

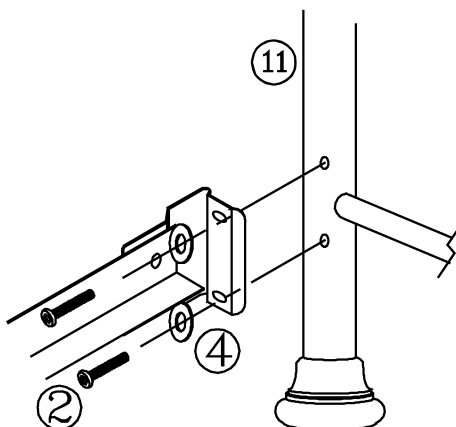









# Parts List For Twin Bed

## BED CARTON

- (10) HEADBOARD PANEL
- (11) FOOTBOARD PANEL

### PART #351501 HARDWARE BAG FOR BED ATTACHMENT TO FRAME

- (1) 1/4-20 2 1/4" COUNTER SUNK ALLEN HEAD SCREW-4
- (2) 1/4-20 1" FLAT ALLEN HEAD SCREW-4
- (3) 5/8" OD FLAT WASHER-8
- (4) 1/4-20 HEX NUT-4
- (5) ALLEN WRENCH
- (6) PLASTIC GLIDE-4
- (7) FINIAL-4
- (8) FOOT CASTING-2
- (9) LEG EXTENSION-2

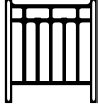
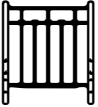
1 	2 	3 	4 	5 	6 	7 
8 	9 		10 		11 	

## PRODUCT FULLY ASSEMBLED

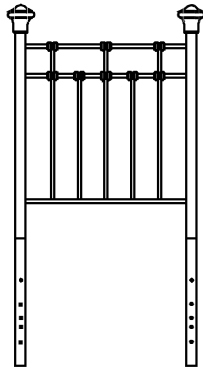

HEADBOARD PANEL

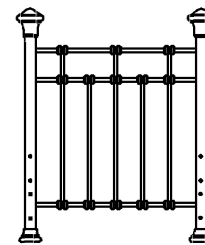

FOOTBOARD PANEL

## Twin Size Options

- 1st. USE LINK SPRING (UPPER CONNECTION) FOR TRUNDLE APPLICATION (ONLY A MATTRESS).
- 2nd. USE FRAME (LOWER CONNECTION) W/BOX SPRING AND MATTRESS.

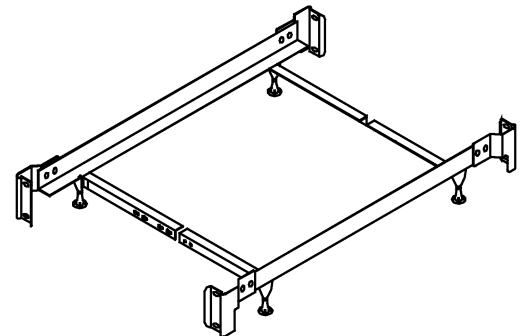
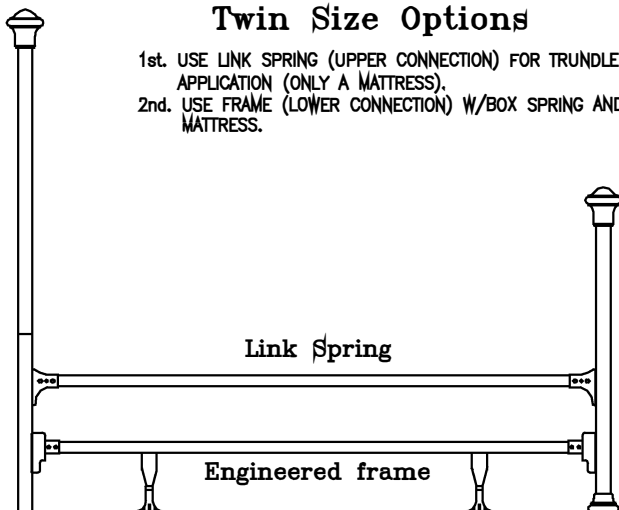

TWIN - FULL FRAME FULLY ASSEMBLED  
NOTE: SEE INSTRUCTIONS INCLUDED IN FRAME CARTON FOR FRAME ASSEMBLY

### OPTIONAL

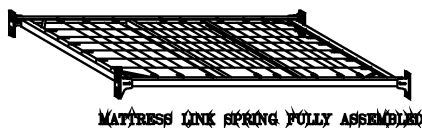

MATTRESS LINK SPRING FULLY ASSEMBLED

### OPTIONAL

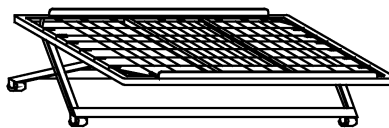

POP-UP TRUNDLE

# Instruction Sheet

SAVE ALL PACKAGING MATERIALS UNTIL PRODUCT IS FULLY ASSEMBLED. HARDWARE AND SMALL PIECES MAY NOT BE SEEN AND BE ACCIDENTALLY DISCARDED WITH PACKAGING MATERIALS.

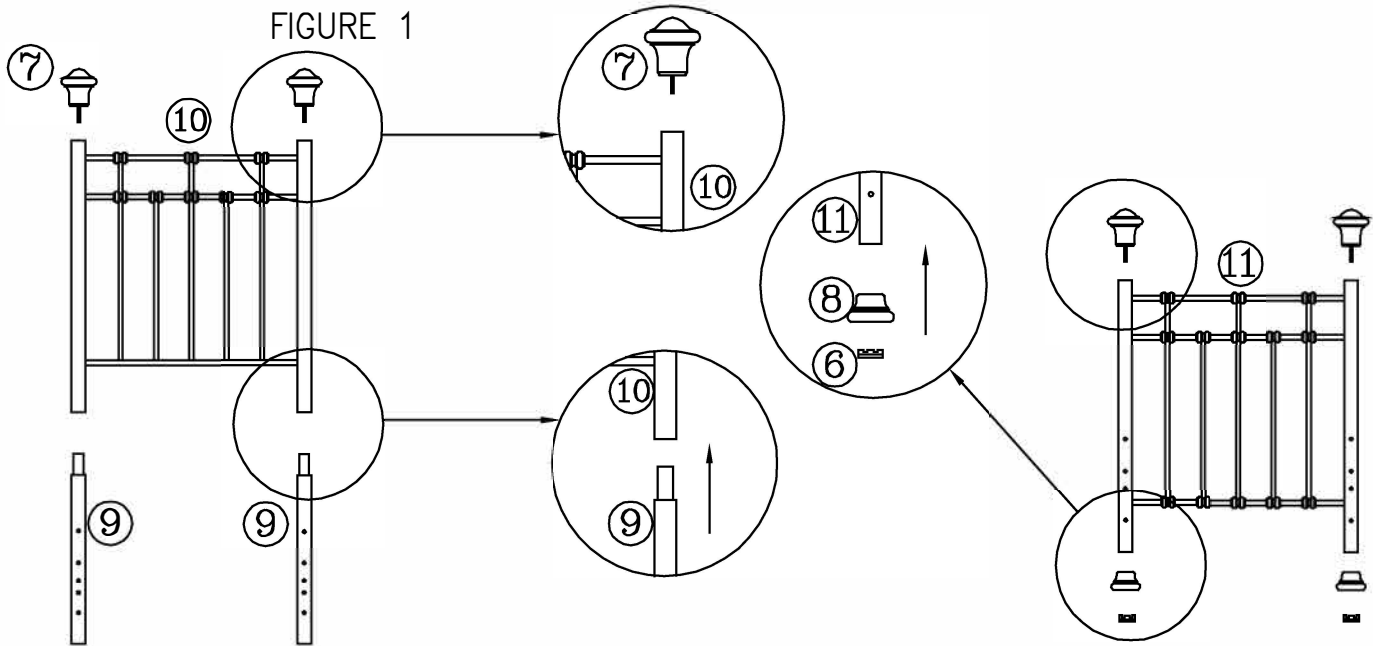
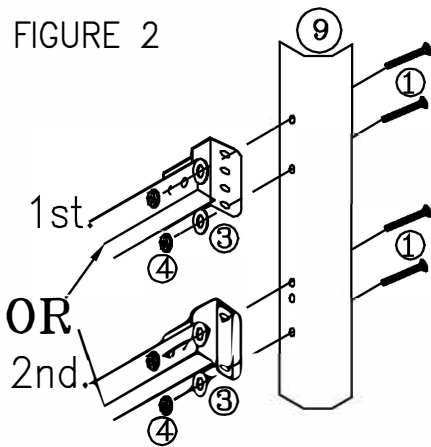

FIGURE 2



## Step 1

- Align top reduction of extension legs (9) with bottom of headboard posts. (See Figure 1) Make sure the 3 holes on extension legs are perpendicular to headboard panel.
- Now carefully insert extension legs (9) into bottom of headboard (10) posts.
- Screw in finials (7) on top of headboard (10) and footboard (11) posts. (See Figure 1)
- Slide foot castings (8) onto bottom of footboard (11) posts. Insert plastic glide (6) into bottom of foot casting.

## Step 2

- Note: YOU HAVE TWO ASSEMBLY OPTIONS WITH A TWIN SIZE:  
1st. USE UPPER ASSEMBLY IF USING AS A TRUNDLE UNIT WITH MATTRESS ONLY.  
2nd. USE LOWER FRAME ASSEMBLY IF USING BOX SPRING & MATTRESS.

FIGURE 3

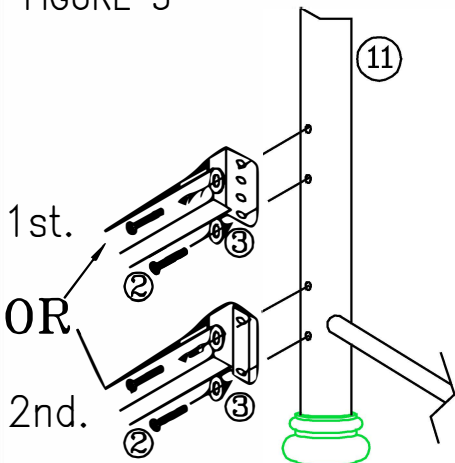

## Step 3

- Place headboard and frame in desire location in room.
  - Place 2 screws (1) through holes located in extension leg (9). (See Fig. 2)
  - Align bed frame bracket over screws.
  - Place a washer (3) and then a nut (4) on each screw. Hand-tighten, DO NOT TIGHTEN screws all the way.
  - Repeat on other side of headboard.
  - Tighten all screws securely using the Allen wrench (5).
- Position footboard panel (11) and align holes in the post with holes in the frame bracket. (See Fig. 3)  
Note: Use the same hole position that you used for the headboard attachment of to the frame or link spring.
  - Place washer (3) on each screw (2). Insert through bracket and into footboard post. (See Fig. 3) Hand-tighten, DO NOT TIGHTEN screws all the way.
  - Repeat on other side of footboard panel.
  - Tighten all screws securely using the Allen wrench (5).