

Model:615582

960542 White

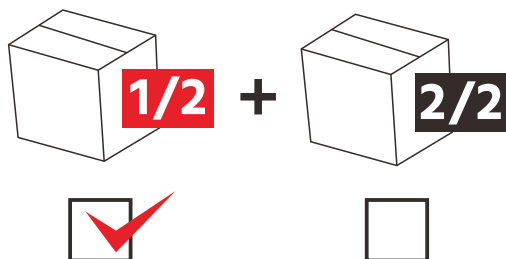

- EN** - Please confirm receipt of all boxes before starting assembly, as the product was shipped in multiple packages.
- DE** - Bitte bestätigen Sie den Erhalt aller Kartons, bevor Sie mit der Montage beginnen, da das Produkt in mehreren Paketen geliefert wurde.
- ES** - Confirme la recepción de todas las cajas antes de empezar el montaje, porque el producto se ha enviado en varios paquetes.
- FR** - Veuillez confirmer la réception de toutes les boîtes avant de commencer l'assemblage, car le produit a été expédié en plusieurs colis.
- IT** - Si prega di verificare la ricezione di tutte le scatole prima di iniziare il montaggio, poiché il prodotto è stato spedito in più pacchi.

EN- 2 boxes in total, This is 1/2 box.

DE- Insgesamt 2 Pakete, Das ist 1/2 Paket.

ES - 2 cajas en total, Esto es 1/2 caja.

FR- 2 boîtes au total, Il s'agit de 1/2 box.

IT - 2 scatole in totale, Questa è una scatola da 1/2.

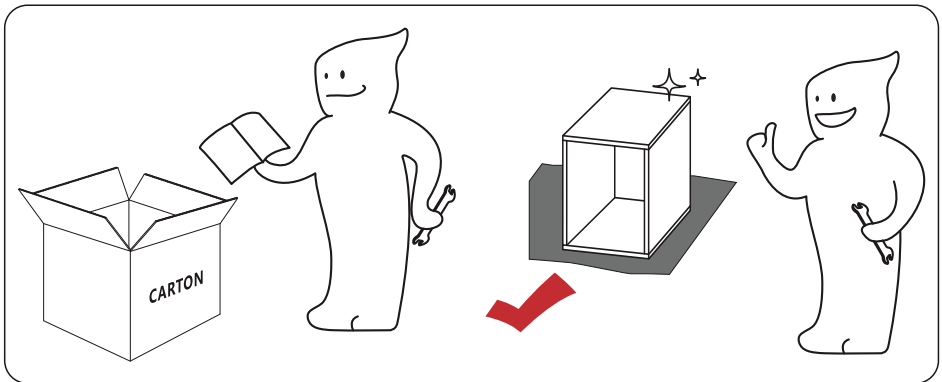
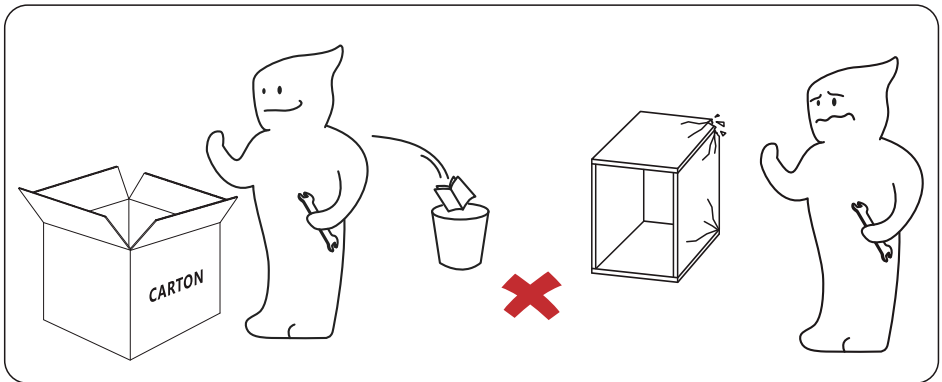
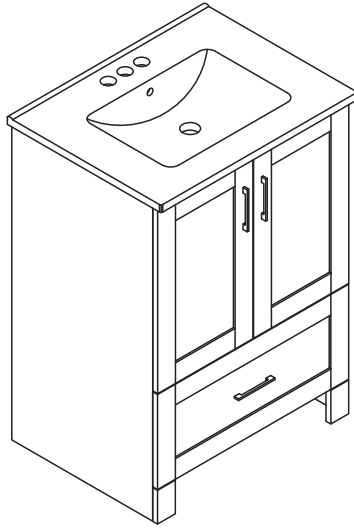

CAUTION

EN

- Keep away from fire or other heat sources.
- We recommend wearing protective gloves.
- Firmly secure all bolts, screws, and knobs before use.
- Every 90 days, check that all nuts, screws, and knobs are securely fastened.
- If any parts are missing, broken, damaged, or worn, stop using this item until repairs are made and/or factory replacement parts are installed.
- Please follow the instruction manuals and use a pad to avoid damage during assembly.

ACHTUNG

DE

- Halten Sie es von Feuer oder anderen Wärmequellen fern.
- Es wird empfohlen, Schutzhandschuhe zu tragen.
- Ziehen Sie alle Bolzen, Schrauben und Knöpfe vor dem Gebrauch fest an.
- Prüfen Sie regelmäßig alle 90 Tage, ob alle Muttern, Schrauben und Knöpfe fest angezogen sind.
- Sollten Teile fehlen, gebrochen, beschädigt oder abgenutzt sein, verwenden Sie das Gerät nicht mehr, bis es repariert und/oder durch Originalersatzteile ersetzt wird.
- Bitte folgen Sie den Anweisungen in der Anleitung und verwenden Sie eine Unterlage, um Schäden bei der Montage zu vermeiden.

PRECAUCION

ES

- Mantener alejado del fuego u otras fuentes de calor.
- Recomendamos usar guantes protectores.
- Asegure firmemente todos los pernos, tornillos y perillas antes de usar.
- Cada 90 días, compruebe que todas las tuercas, tornillos y pomos estén bien apretados.
- Si falta alguna pieza, está rota, dañada o desgastada, deje de utilizar este artículo hasta que se realicen las reparaciones y/o se instalen las piezas de repuesto de fábrica.
- Por favor, siga los manuales de instrucciones y utilice una almohadilla para evitar daños durante el montaje.

ATTENTION

FR

- Éloignez l'appareil de toute source de chaleur ou de flammes.
- Il est recommandé de porter des gants de protection.
- Assurez-vous de bien serrer tous les boulons, vis et boutons avant d'utiliser l'appareil.
- Tous les 90 jours, assurez-vous que tous les écrous, vis et boutons sont correctement serrés.
- Si vous constatez des pièces manquantes, cassées, endommagées ou usées, cessez d'utiliser l'appareil jusqu'à ce qu'il soit réparé et/ou que des pièces de rechange d'origine soient installées.
- Veuillez suivre les instructions du manuel et utilisez un coussin de protection pour éviter d'endommager l'appareil pendant l'assemblage.

ATTENZIONE

IT

- Tenere lontano dal fuoco o da altre fonti di calore.
- Si consiglia di indossare guanti protettivi.
- Prima dell'uso, fissare saldamente tutti i bulloni, le viti e le manopole.
- Ogni 90 giorni, controllare che tutti i dadi, i bulloni e le manopole siano saldamente fissati.
- Se si riscontrano parti mancanti, rotte, danneggiate o usurate, interrompere l'uso dell'apparecchio fino a quando non saranno effettuate le riparazioni e/o montate le parti di ricambio originali.
- Seguire le istruzioni per l'uso e utilizzare un cuscinetto per evitare danni durante il montaggio.

EN



2 PERSON ASSEMBLY

90

MIN ASSEMBLY

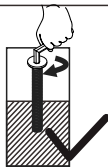

HALF TIGHTEN THE
SCREW

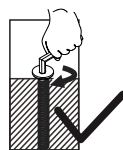

TIGHTEN ALL SCREWS
COMPLETELY

DE



2 PERSON MONTAGE

90

MIN. MONTAGE

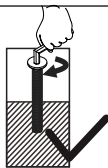

SCHRAUBE HALB
ANZIEHEN

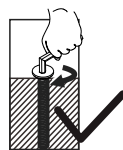

ALLE SCHRAUBEN
VOLLSTÄNDIG
FESTZIEHEN

ES



MONTAJE POR 2
PERSONA

90

MONTAJE MIN

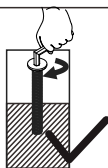

PRIETE EL TORNILLO
HASTA LA MITAD

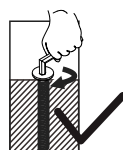

APRIETE
COMPLETAMENTE
TODOS LOS TORNILLOS

FR



ASSEMBLAGE PAR 2
PERSONNE

90

MINUTES
D'ASSEMBLAGE

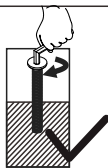

SERRER LA MOITIÉ
DE LA VIS

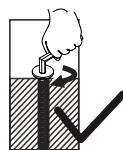

SERREZ
COMPLÈTMENT LA VIS

IT



MONTAGGIO PER 2
PERSONA

90

MONTAGGIO
MINIMO

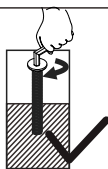



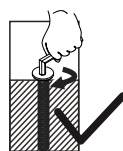

SERRARE A METÀ
LA VITE



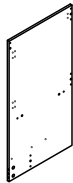

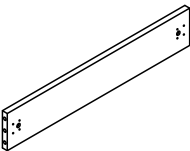
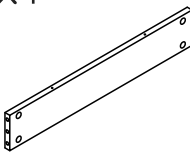
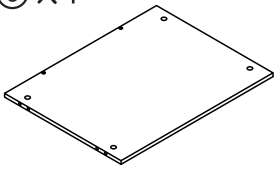
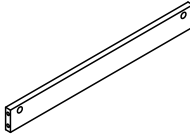
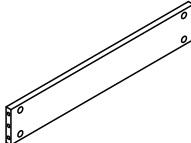

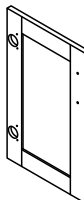
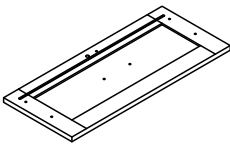
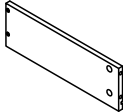
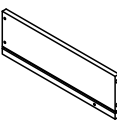
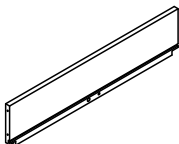
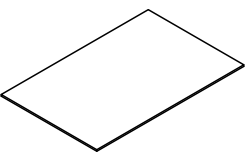
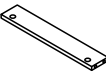
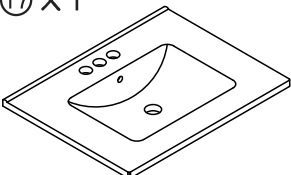
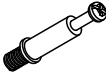



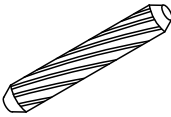

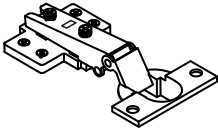
SERRARE
COMPLETAMENTE
TUTTE LE VITI

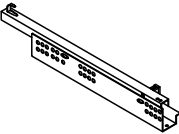
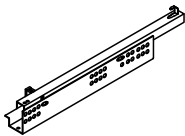
Total Parts List

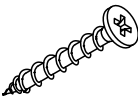
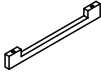
① × 1  L	② × 1  R	③ × 1 
④ × 1 	⑤ × 1 	⑥ × 1 
⑦ × 1 	⑧ × 2 	⑨ × 1  L
⑩ × 1  R	⑪ × 1 	⑫ × 1  L
⑬ × 1  R	⑭ × 1 	⑮ × 1 
⑯ × 1 	⑰ × 1 	Ⓐ × 28 

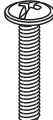
Total Parts List

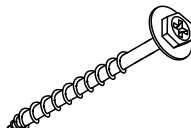
<p>Ⓑ × 14</p>  <p>11mm</p>	<p>Ⓒ × 16</p> 	<p>Ⓓ × 14</p>  <p>9mm</p>
<p>Ⓔ × 4</p> 	<p>Ⓕ × 30</p> 	<p>Ⓖ × 1 L</p> 
<p>Ⓗ × 1 R</p> 	<p>Ⓘ × 2</p> 	<p>Ⓙ × 12</p> 
<p>Ⓚ × 6</p> 	<p>Ⓛ × 3</p> 	<p>Ⓜ × 2</p> 
<p>Ⓝ × 4</p> 	<p>Ⓞ × 2</p> 	<p>Ⓟ × 2</p> 

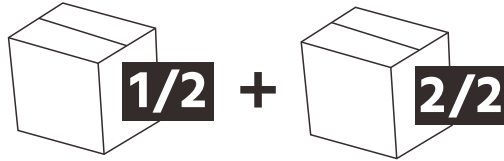

EN - Here are the parts lists for each box:

DE - Hier sind die Teilelisten für jede Box:

ES - Aquí están las listas de piezas para cada caja:





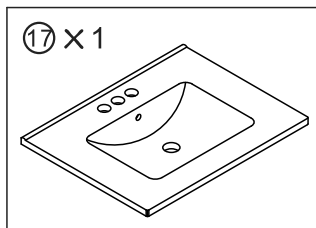

FR - Vous trouverez ci-dessous une liste de pièces pour chaque boîte :

IT - Ecco l'elenco delle parti per ciascuna scatola:



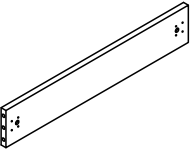
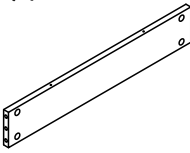
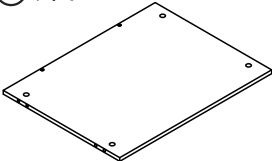
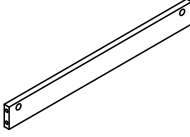
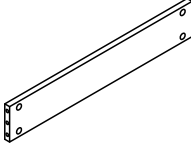

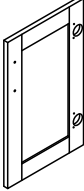
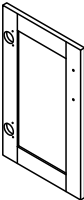
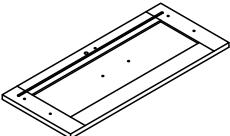
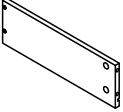
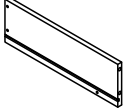
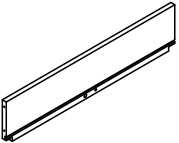
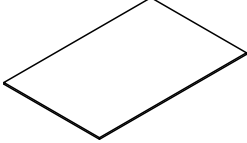
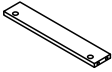

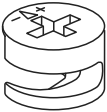

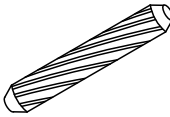

Parts List of Box 1/2

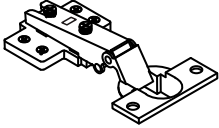

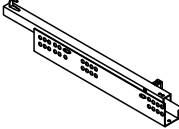
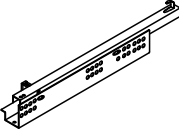
Parts List of Box 2/2

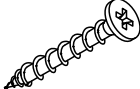
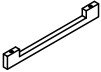
① × 1  L	② × 1  R	③ × 1 
④ × 1 	⑤ × 1 	⑥ × 1 
⑦ × 1 	⑧ × 2 	⑨ × 1  L
⑩ × 1  R	⑪ × 1 	⑫ × 1  L
⑬ × 1  R	⑭ × 1 	⑮ × 1 
⑯ × 1 	Ⓐ × 28 	Ⓑ × 14  11mm

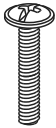
Parts List of Box 2/2

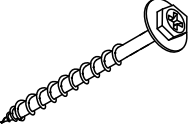
<p>Ⓒ × 16</p> 	<p>Ⓓ × 14</p>  <p>9mm</p>	<p>Ⓔ × 4</p> 
<p>Ⓕ × 30</p> 	<p>Ⓖ × 1 L</p> 	<p>Ⓕ × 1 R</p> 
<p>Ⓖ × 2</p> 	<p>Ⓙ × 12</p> 	<p>Ⓚ × 6</p> 
<p>Ⓛ × 3</p> 	<p>Ⓜ × 2</p> 	<p>Ⓝ × 4</p> 
<p>Ⓞ × 2</p> 	<p>Ⓟ × 2</p> 	

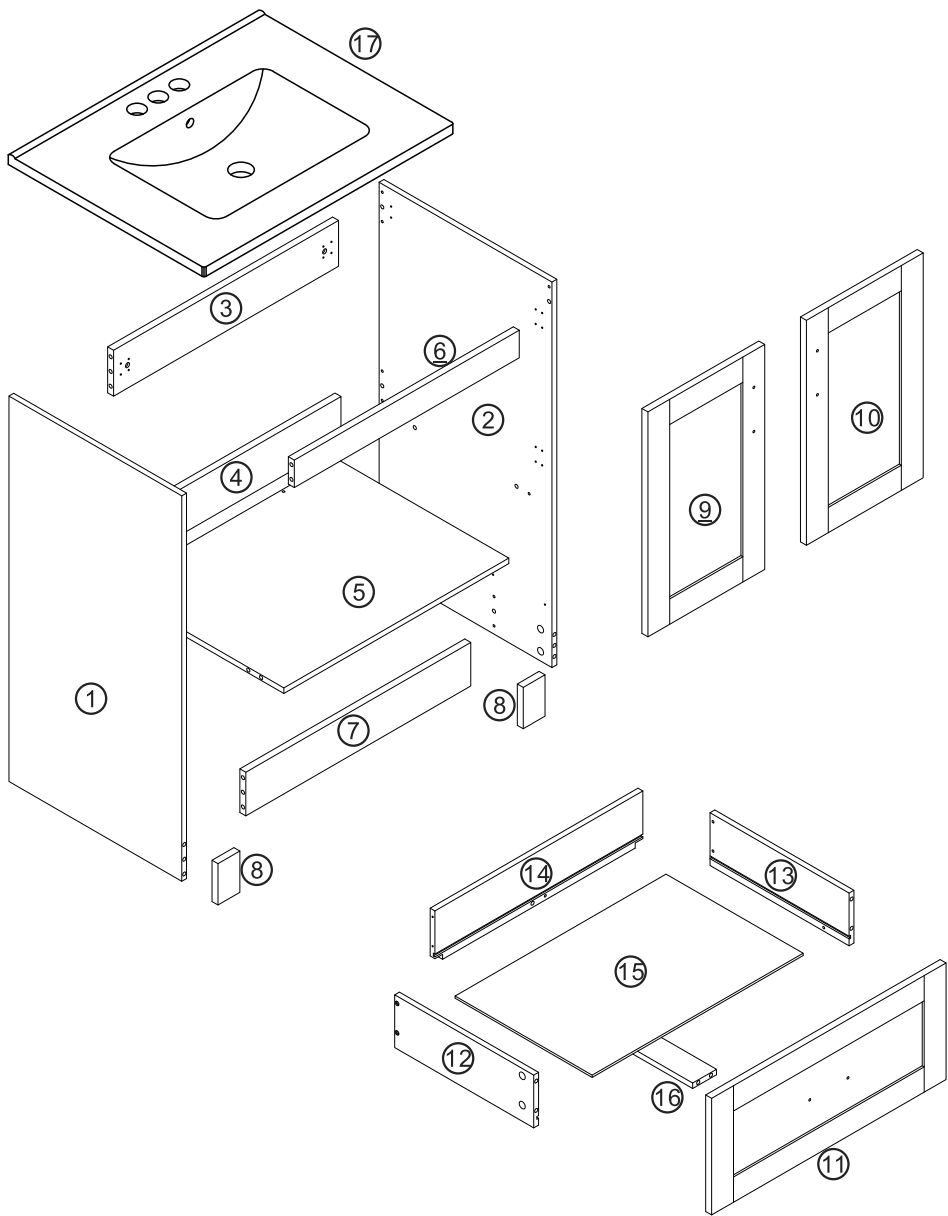



- EN** - Half tighten the screw
DE - Bitte die Schraube nur halb festziehen
ES - Apretar el tornillo a la mitad
FR - Ne serrez la vis que jusqu'à la moitié
IT - Stringere la vite a metà

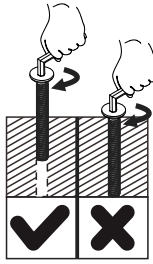

- EN** - Note: Tighten all screws completely after assembly.
DE - Hinweis: Ziehen Sie nach der Montage alle Schrauben vollständig an.
ES - Nota: Apretar completamente todos los tornillos después de montar.
FR - NB : Serrez les vis complètement après l'assemblage.
IT - Nota: Stringere completamente tutte le viti solo dopo l'assemblaggio.

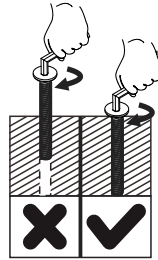





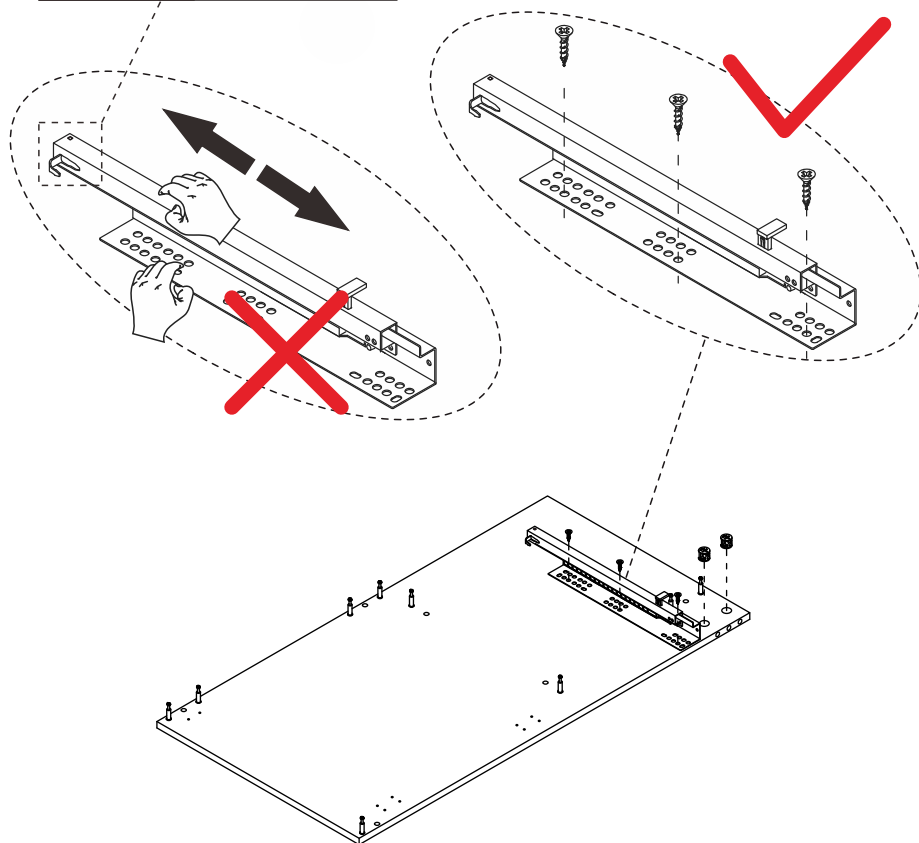

- EN** - Do not slide it to avoid injuring your hand, before the drawer slide rail is fastened with screws. It can be slid after fixing.
- DE** - Um Verletzungen an den Händen zu vermeiden, sollten Sie darauf achten, daß die Schubladenföhrung erst nach der Befestigung mit den passenden Schrauben geschoben werden darf.
- ES** - Antes de fijar la guía de deslizamiento del cajón con tornillos, no la deslice para evitar hacerse daño en la mano. Se puede deslizar después de fijarlo.
- FR** - N'étéirez pas la coulisse du tiroir avant de l'avoir fixée avec des vis, vous risquez de vous blesser la main. Vous pouvez la faire coulisser une fois fixée.
- IT** - Non allungare la guida del cassetto prima di fissarla con le viti, per evitare di ferirsi la mano. È possibile tirarlo dopo il fissaggio.







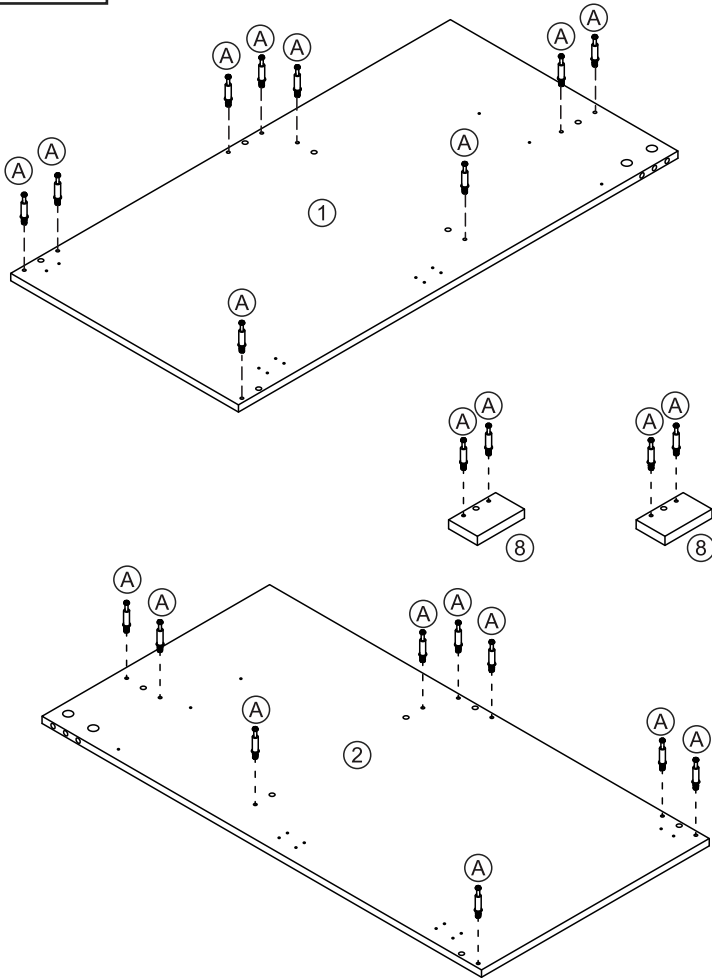



1

①		x1
②		x1
⑧		x2
Ⓐ		x22







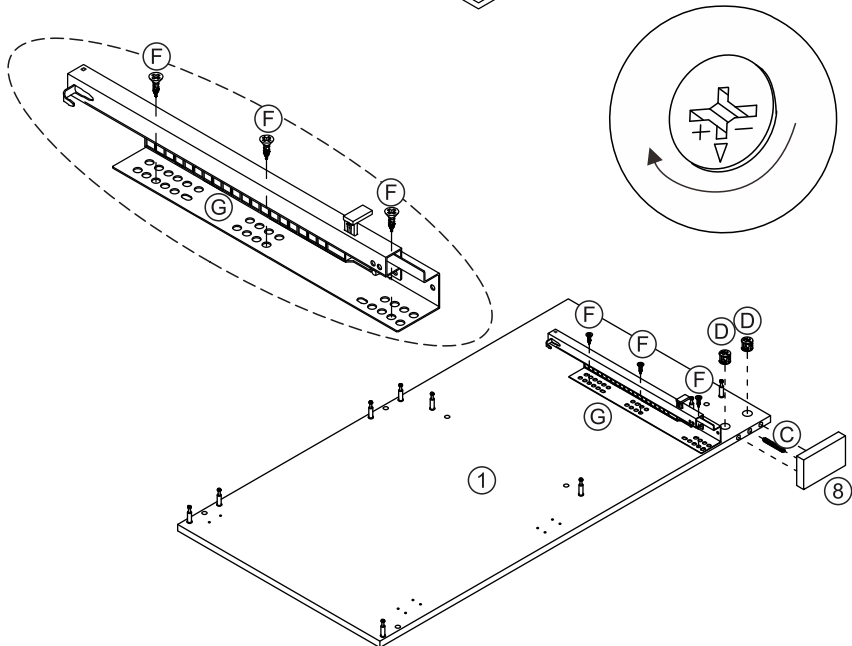
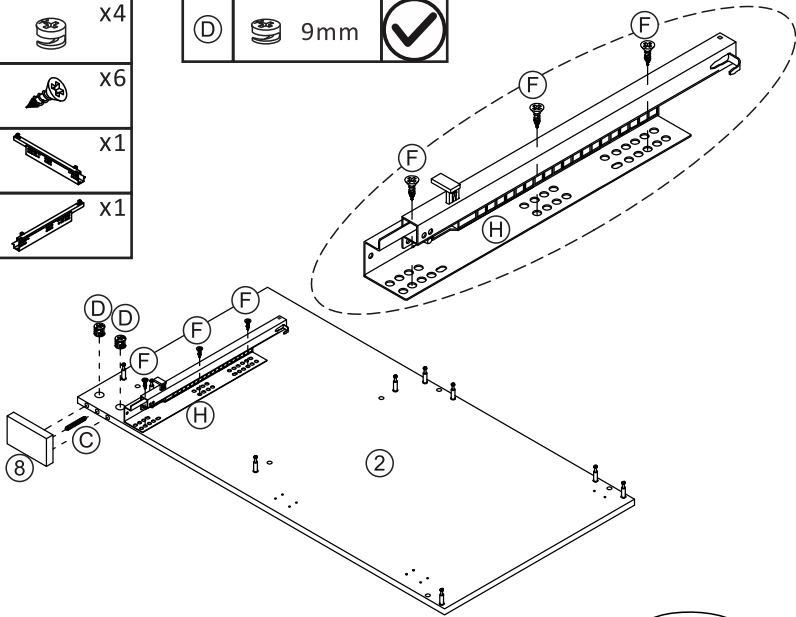

2





(C)		X2
(D)		X4
(F)		X6
(G)		X1
(H)		X1

(B)		11mm	
(D)		9mm	





3

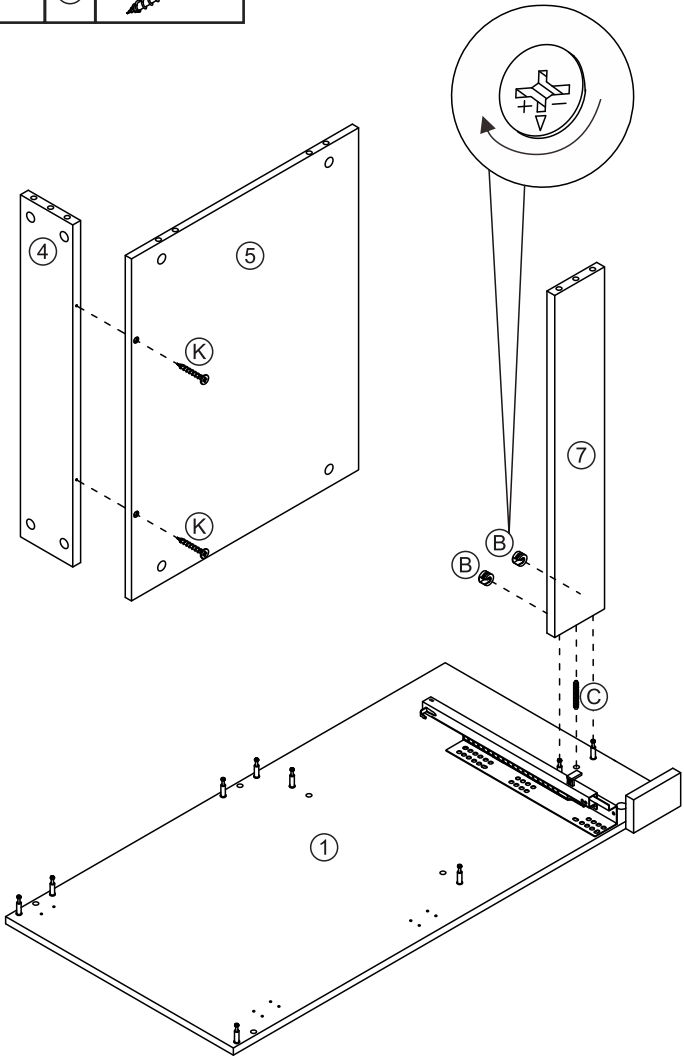

④	 x1	Ⓑ	 x2
⑤	 x1	Ⓒ	 x1
⑦	 x1	Ⓚ	 x2

Ⓑ	 11mm	
Ⓓ	 9mm	





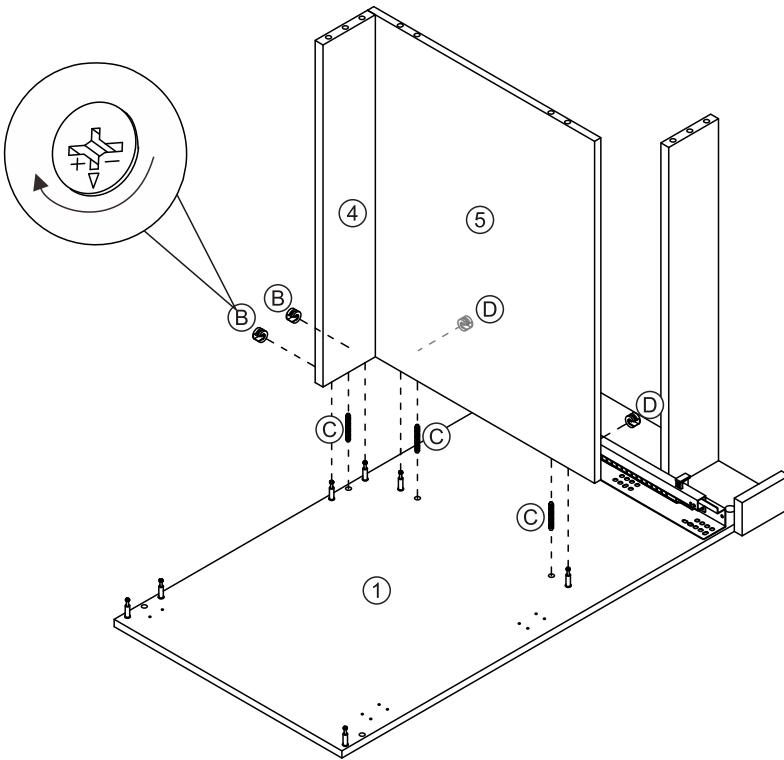

4

(B)		x2
(C)		x3
(D)		x2

(B)		11mm
(D)		9mm



5

③		x1
⑥		x1
(B)		x3
(C)		x2

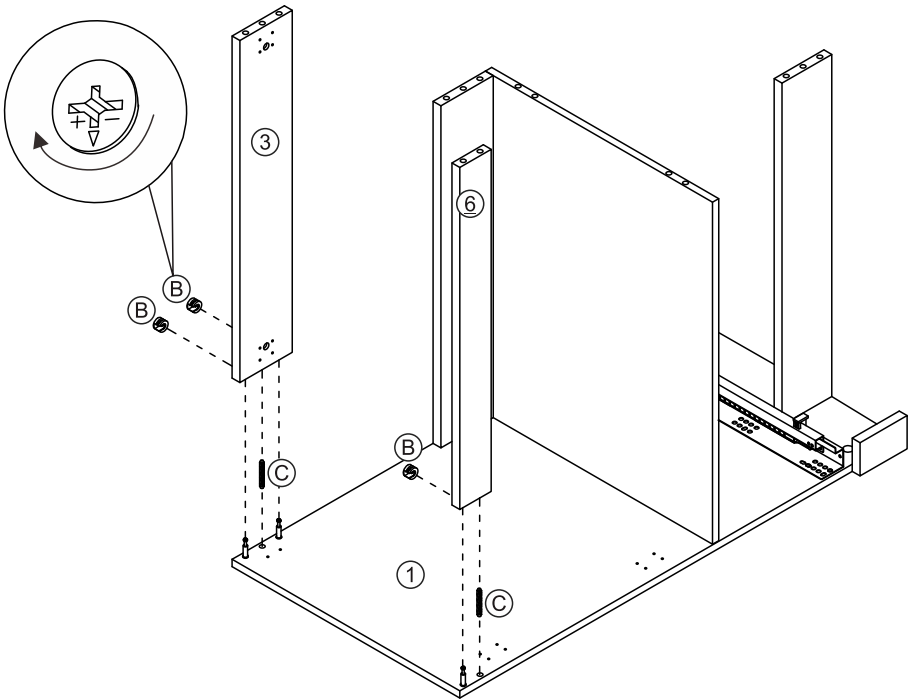

(B)	 11mm	
(D)	 9mm	



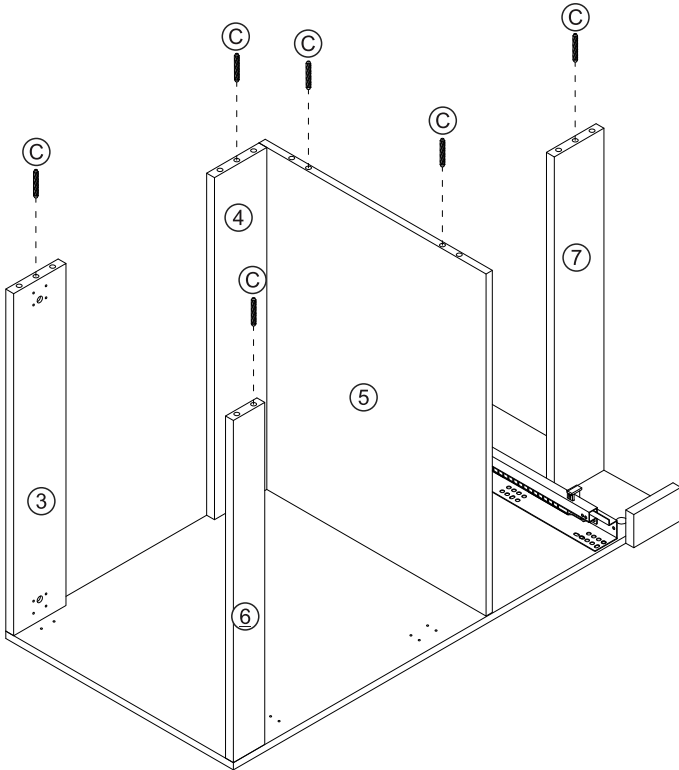

6







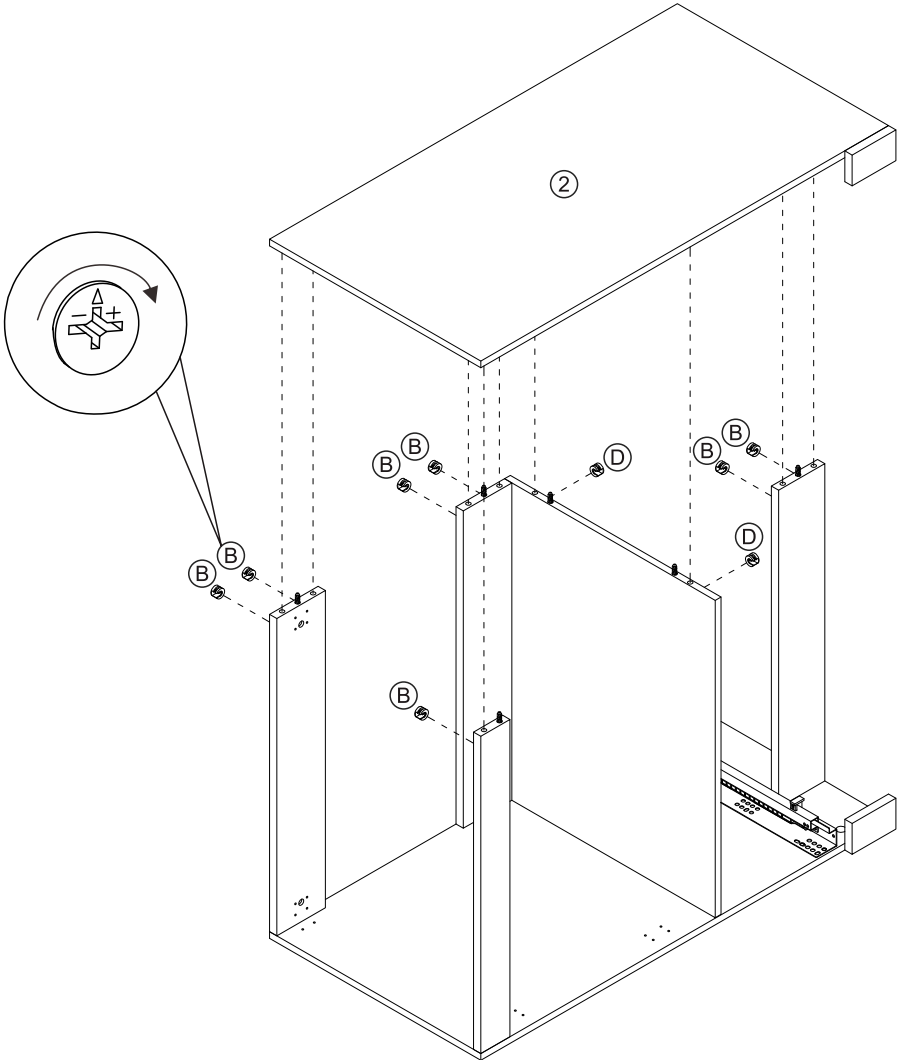

7

(B)		x7
(D)		x2

(B)		11mm
(D)		9mm



8

⑨		x1	ⓕ		x8
⑩		x1	Ⓛ		x2
ⓔ		x4	Ⓝ		x4

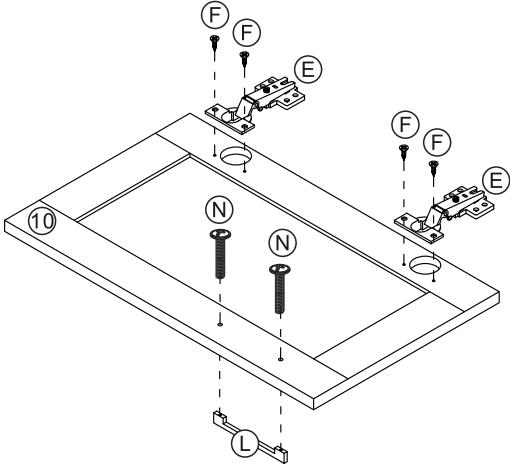
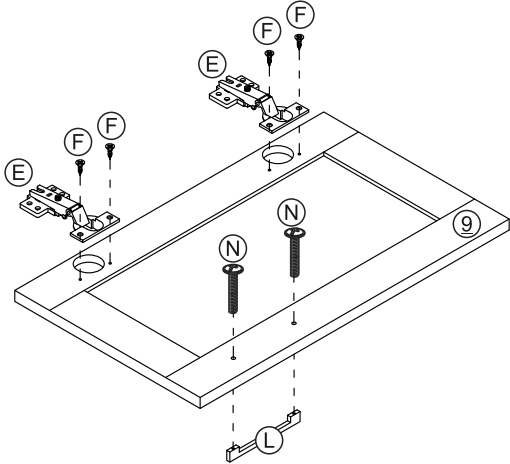

9



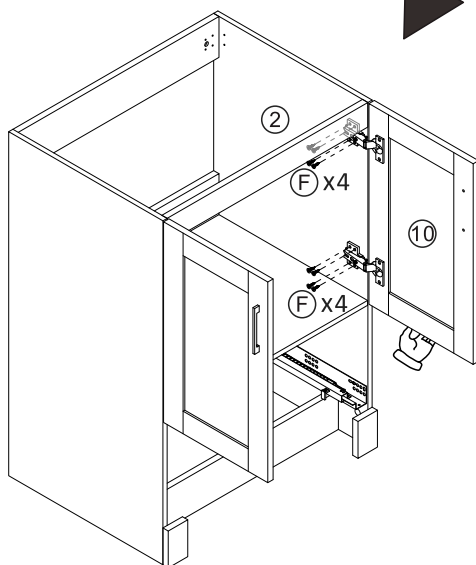
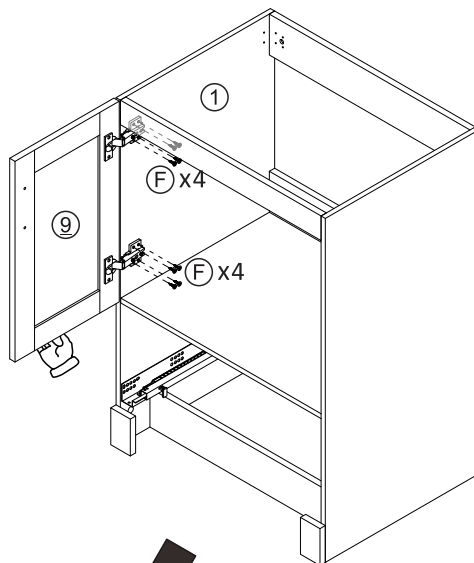

EN - Assembly requires 2 adults.
DE - Die Montage erfordert 2 Erwachsene.
ES - Para el montaje se necesitan 2 adultos.
FR - L'assemblage nécessite 2 adultes.
IT - Il montaggio richiede 2 adulti.

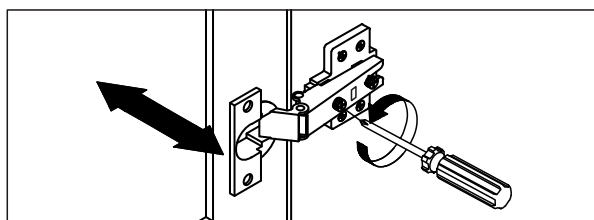
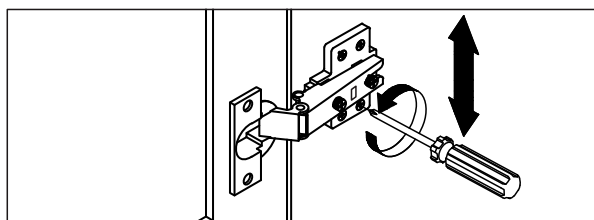
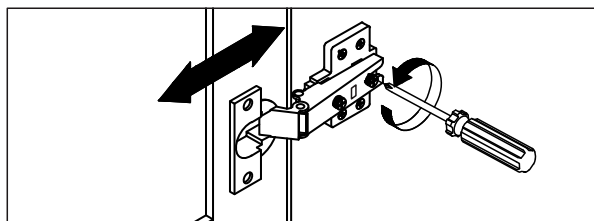









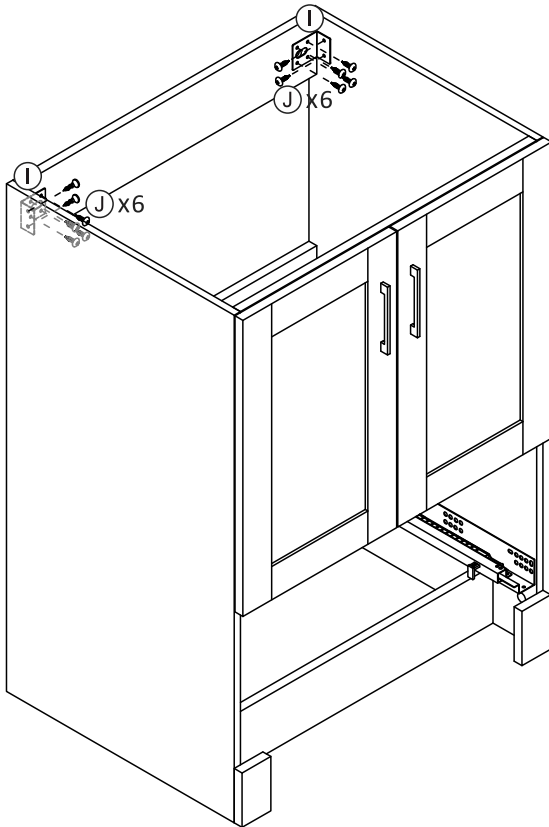





- EN** - Loosen the screws on Part ⑤, then you can adjust the position of the door.
- DE** - Lösen Sie die Schrauben an Teil ⑤, um die Tür auszurichten.
- ES** - Afloje los tornillos de la pieza ⑤ para poder ajustar la posición de la puerta.
- FR** - Serrez/desserrez les vis des charnières ⑤ pour ajuster la position de la porte.
- IT** - Allentare le viti sulla Parte ⑤, quindi è possibile regolare la posizione dello sportello.

10





I	 x2
J	 x12

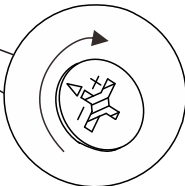
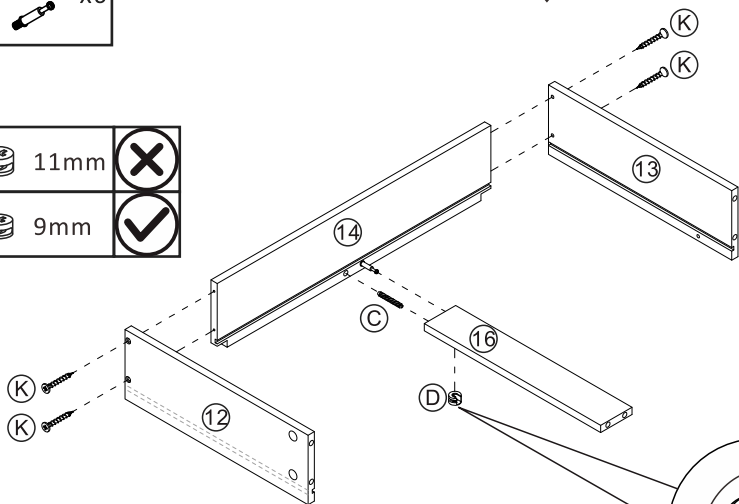
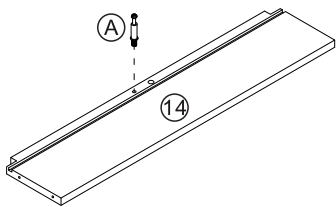

11



①①	 x1	Ⓒ	 x1
①②	 x1	Ⓓ	 x1
①③	 x1	Ⓚ	 x4
①④	 x1	Ⓛ	 x1
①⑥	 x1	Ⓜ	 x2
Ⓐ	 x6		



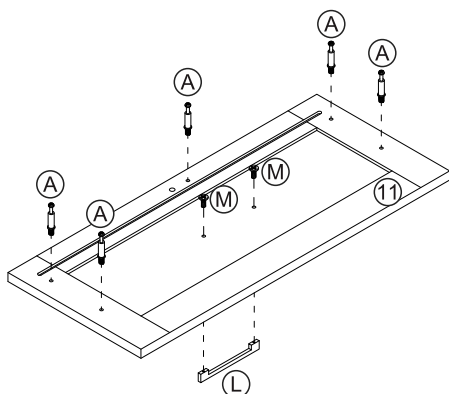



Ⓑ	 11mm	
Ⓓ	 9mm	



12

⑮		x1
Ⓒ		x1
Ⓓ		x5

Ⓑ	 11mm	
Ⓓ	 9mm	

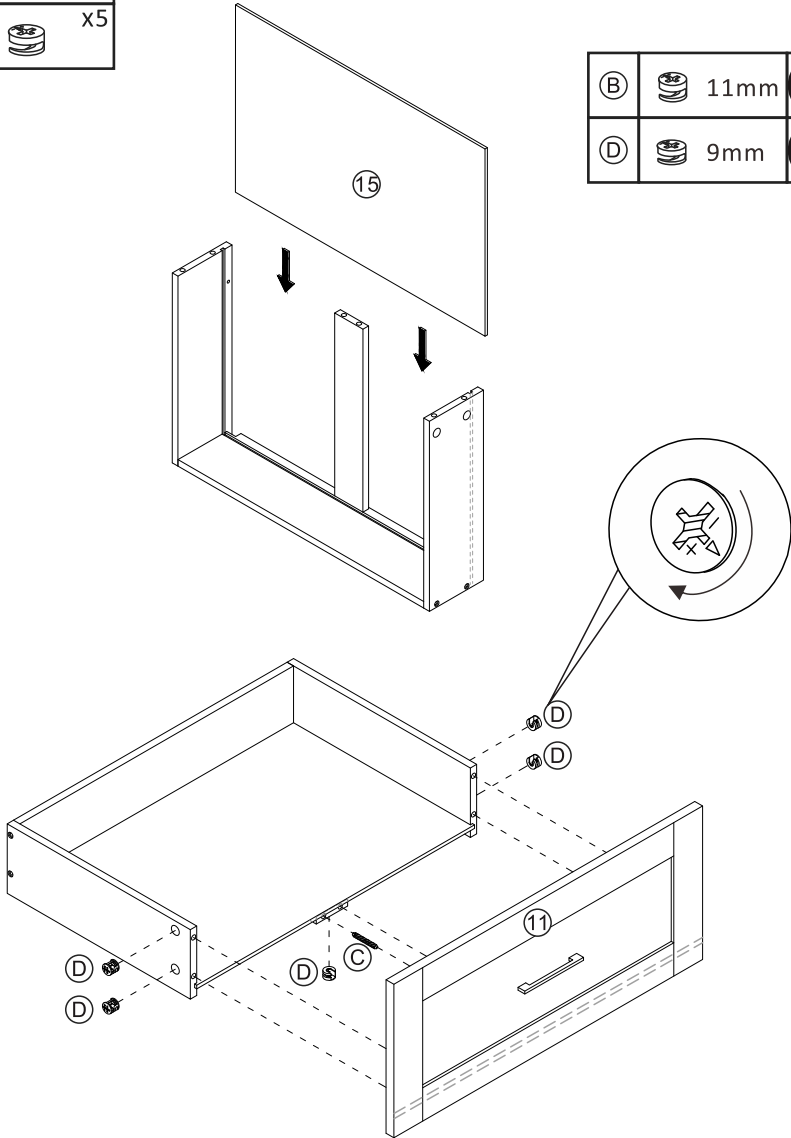

13

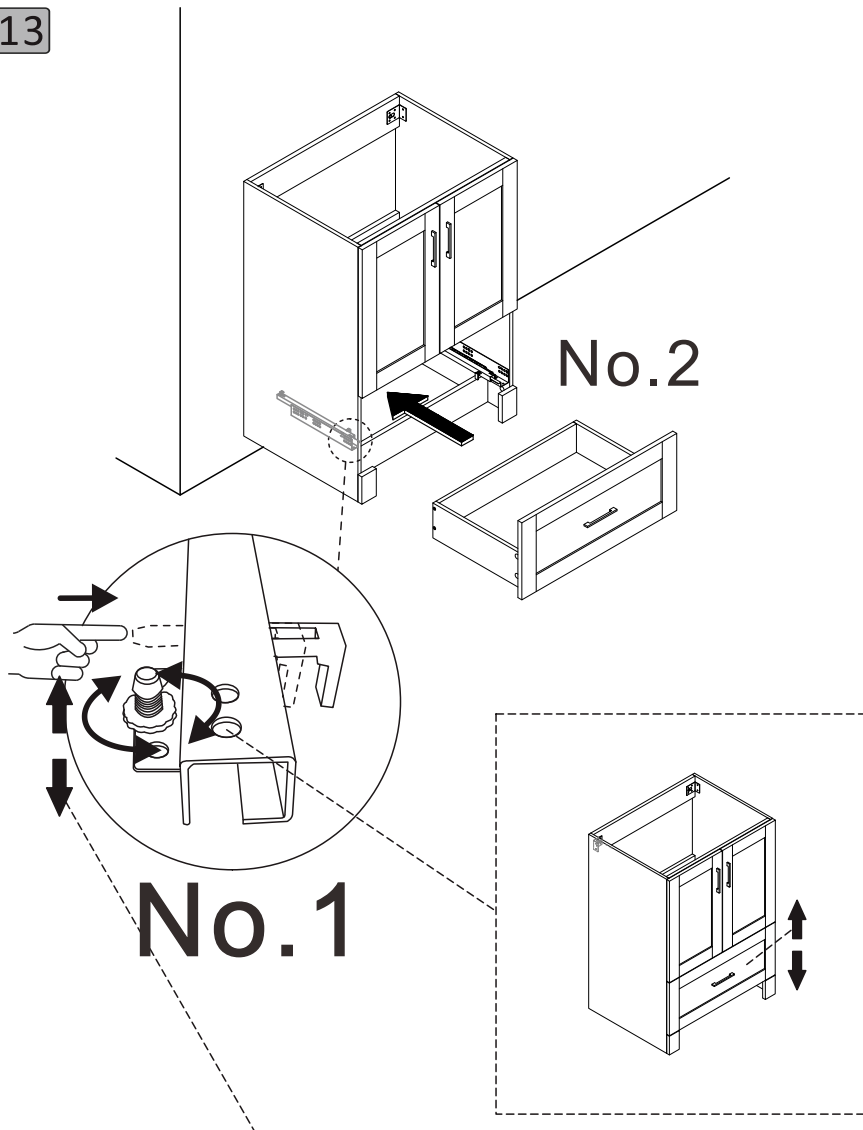

- EN** - Rotate the nut plate on the slide rail (G&H) to adjust the spacing between drawers.
- DE** - Drehen Sie die Mutterplatte auf der Führung (G&H), um den Abstand zwischen den Schubladen einzustellen.
- ES** - Gire la placa de tuerca de la guía de deslizamiento (G&H) para ajustar la separación entre cajones.
- FR** - Tournez la plaque d'écrou sur la glissière (G&H) afin d'ajuster l'espacement entre les tiroirs.
- IT** - Ruotare il dado della guida (G&H) per regolare la distanza tra i cassetti.

14

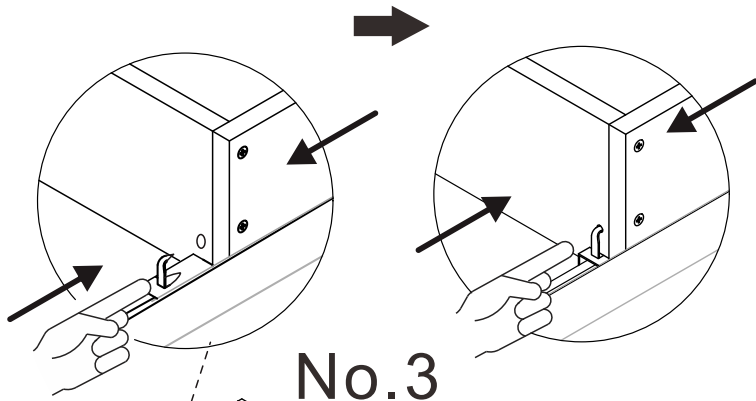

No.3

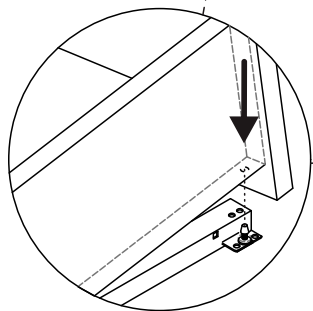
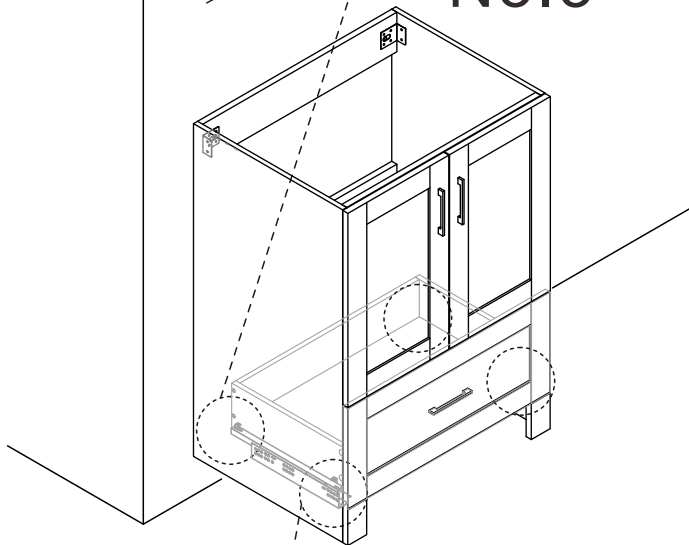

No.4

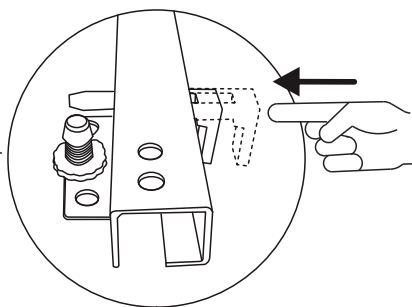

No.5

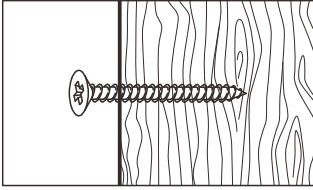

Drywall or plaster with available wood stud:

- Mark the attachment point(s) with a pencil at the appropriate height and positioned over wood stud(s).
- Drill a pilot hole(s) with a diameter that matches the screw into the wood stud(s), at the height you marked with pencil.
- Secure the screw to the wood firmly as the picture shows.

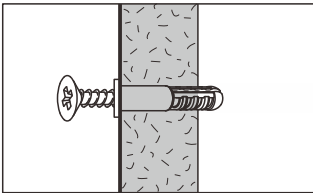

Drywall without available wood stud:

- Mark the attachment point(s) with a pencil at the appropriate height.
- Drill a hole(s) with a diameter that matches the plastic anchor through the wall at the height you marked with pencil.
- Drive the plastic plug(s) into the hole(s), using a hammer if needed.
- Insert the screw into the plastic plug firmly as the picture shows. Do not over-tighten.

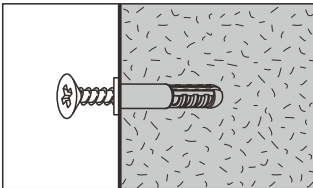

Masonry:

- Mark the attachment point(s) with a pencil at the appropriate height.
- Drill a hole(s) with a diameter and depth that match the plastic anchor through the wall at the height you marked with pencil.
- Drive the plastic plug(s) into the hole(s), using a hammer if needed.
- Insert the screw into the plastic plug firmly as the picture shows. Do not over-tighten.

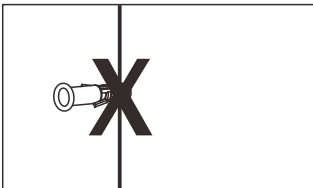

If the screw can't be secured to the wall, please keep the product away from children.

If your wall material is not listed here, or if you have any questions, consult your local hardware store.

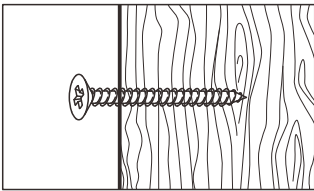

Trockenbau mit zugänglicher Holzstruktur:

- Markieren Sie den (die) Befestigungspunkt (e) mit einem Bleistift in der entsprechenden Höhe und über dem (den) Holzständer(n).
- Bohren Sie ein Vorbohrloch bzw. Vorbohrlöcher mit einem zur Schraube passenden Durchmesser in der von Ihnen mit Bleistift markierten Höhe in den/die Holzpfosten.
- Befestigen Sie die Schraube fest im Holz, wie auf dem Bild gezeigt.

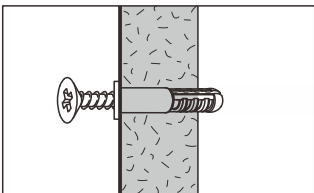

Trockenbauwand mit Hohlraum:

- Markieren Sie den (die) Befestigungspunkt(e) mit einem Bleistift in der entsprechenden Höhe.
- Bohren Sie ein Vorbohrloch bzw. Vorbohrlöcher mit einem zum Dübel passenden Durchmesser in der von Ihnen mit Bleistift markierten Höhe in die Trockenbauwand.
- Drücken Sie den/die Kunststoffdübel in das/die Loch/Löcher, wenn nötig mit leichten Hammerschlägen.
- Drehen Sie die Schraube fest in den Kunststoffdübel ein, wie in der Abbildung gezeigt. Nicht zu fest anziehen.

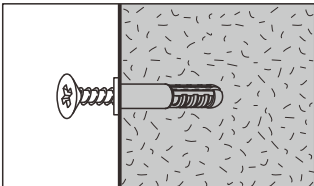

Mauerwerk:

- Markieren Sie den (die) Befestigungspunkt(e) mit einem Bleistift in der entsprechenden Höhe.
- Bohren Sie ein Vorbohrloch bzw. Vorbohrlöcher mit einem zum Dübel passenden Durchmesser in der von Ihnen mit Bleistift markierten Höhe in das Mauerwerk.
- Drücken Sie den/die Kunststoffdübel in das/die Loch/Löcher, wenn nötig mit Hammerschlägen.
- Drehen Sie die Schraube fest in den Kunststoffdübel ein, wie in der Abbildung gezeigt. Nicht zu fest anziehen.

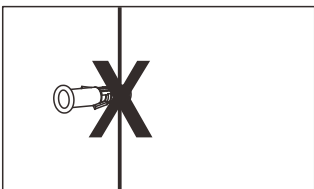

Bitte das Produkt von Kindern fernhalten.

Wenn die Schraube nicht an der Wand befestigt werden kann, oder Ihr Wandmaterial hier nicht aufgeführt ist oder wenn Sie Fragen haben, wenden Sie sich an Ihren örtlichen Eisenwarenhändler.

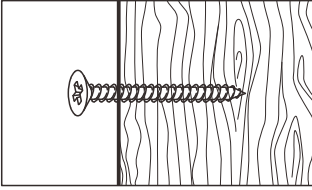

Paneles o muros de yeso donde se pueda usar tornillos para madera:

- Marque los puntos de fijación con un lápiz a la altura adecuada donde pondrá los tornillos.
- A la altura marcada con el lápiz, taladre un orificio piloto que coincida con el tamaño del tornillo.
- Asegure el tornillo a la madera firmemente como se muestra en la foto.

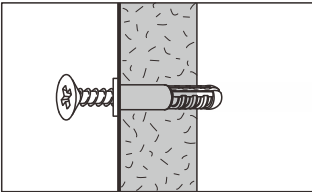

Paneles o muros de yeso donde no se pueda usar tornillos para madera:

- Marque los puntos de fijación con un lápiz a la altura adecuada donde pondrá los tornillos.
- A la altura marcada con el lápiz, taladre un agujero que coincida con el diametro del taquete.
- Inserte el taquete en el agujero. Use un martillo si fuera necesario.
- Inserte el tornillo firmemente como se muestra en la imagen. No apriete demasiado.

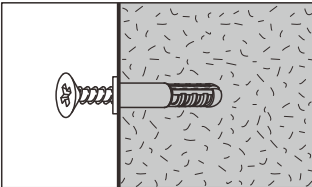

Mampostería:

- Marque los puntos de fijación con un lápiz a la altura adecuada donde pondrá los tornillos.
- A la altura marcada con el lápiz, taladre un agujero que coincida con el diametro del taquete.
- Inserte el taquete en el agujero. Use un martillo si fuera necesario.
- Inserte el tornillo firmemente como se muestra en la imagen. No apriete demasiado.

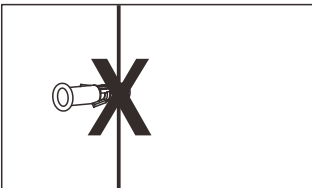

Si el tornillo no se puede fijar a la pared, mantenga el producto alejado de los niños.

Si el material de su pared no figura aquí, o si tiene alguna pregunta, consulte con su ferretería local.

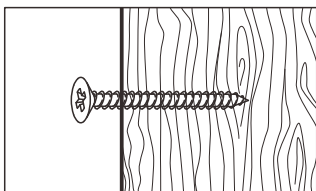

Cloison sèche ou plâtre avec du bois:

- Marquez le/les repère(s) de fixation au crayon à la hauteur qui convient sur le/les montants de bois.
- Percez un/des avant-trou(s) d'un diamètre correspondant à celui de la vis sur le repère.
- Fixez fermement la vis dans le bois comme sur le dessin.

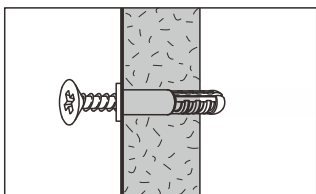

Cloison sèche (sans bois):

- Marquez le/les repère(s) de fixation au crayon à la hauteur qui convient.
- Percez un/des trou(s) d'un diamètre correspondant à celui de la cheville en plastique sur le repère.
- Introduisez la/les cheville(s) en plastique dans le/les trou(s), au besoin avec un marteau.
- Insérez la vis dans la cheville fermement, comme sur le dessin. Ne vissez pas trop loin.

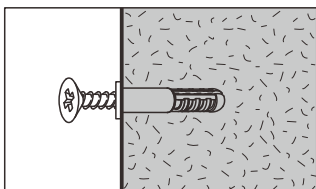

Mur plein (béton, pierre...):

- Marquez le/les repère(s) de fixation au crayon à la hauteur qui convient.
- Percez un/des trou(s) d'un diamètre et d'une profondeur correspondant à la cheville en plastique sur le repère.
- Introduisez la/les cheville(s) en plastique dans le/les trou(s), au besoin avec un marteau.
- Insérez la vis dans la cheville fermement, comme sur le dessin. Ne vissez pas trop loin.

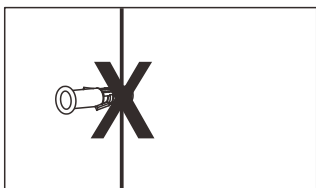

S'il n'est pas possible de fixer le meuble au mur avec une vis, tenir le produit éloigné des enfants.

Si le matériau de votre mur n'est pas listé ici ou si vous avez des questions, renseignez-vous auprès de votre magasin de bricolage.

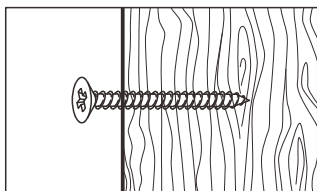
Cartongesso o intonaco con perno di legno disponibile:

- Con una matita, segnare il punto di fissaggio nell'altezza appropriata e posizionarlo sui perni di legno.
- Forare un punto pilota con un diametro che si accordi con la vite nei perni di legno, nell'altezza segnalata in precedenza con la matita.
- Fissare saldamente la vite come mostra l'immagine.

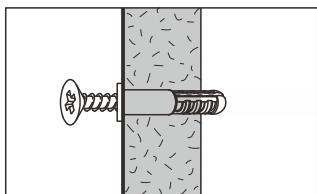
Cartongesso senza perchio di legno disponibile:

- Segnalare un punto di fissaggio con una matita nell'altezza appropriata.
- Forare un punto nell'altezza segnalata con un diametro che si accordi con la plastica per il fissaggio.
- Spingere il tappo di plastica attraverso il muro. Usare un martello se necessario.
- Inserire saldamente la vite nel tappo di plastica, come mostrato nell'immagine. Non stringere più del necessario.

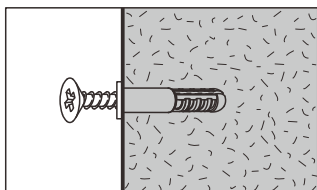
Muratura:

- Segnalare un punto di fissaggio con una matita nell'altezza appropriata.
- Nell'altezza segnalata con la matita in precedenza, forare un punto con diametro e profondità in accordo con la plastica per il fissaggio.
- Spingere il tappo di plastica nel muro, se necessario utilizzare un martello.
- Inserire saldamente la vite nel tappo di plastica, come mostrato nell'immagine. Non stringere più del necessario.

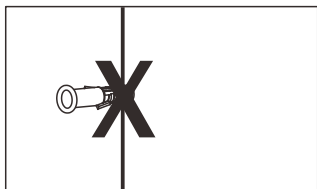

Se la vite non può essere fissata regolarmente al muro, tenere il prodotto lontano dai bambini.

Se il materiale del muro non è presente in questa lista, o in caso di altre domande, consultare il ferramenta della tua zona.

15

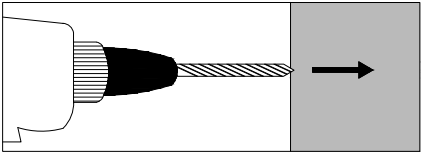
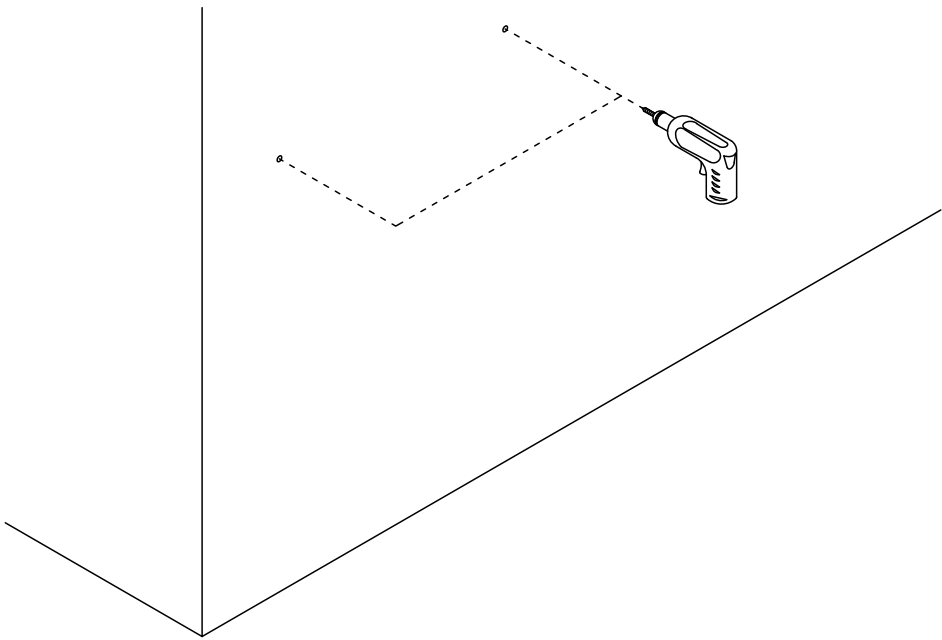
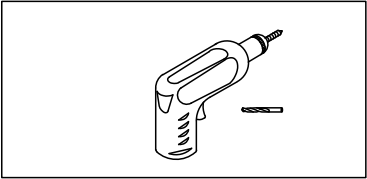

16

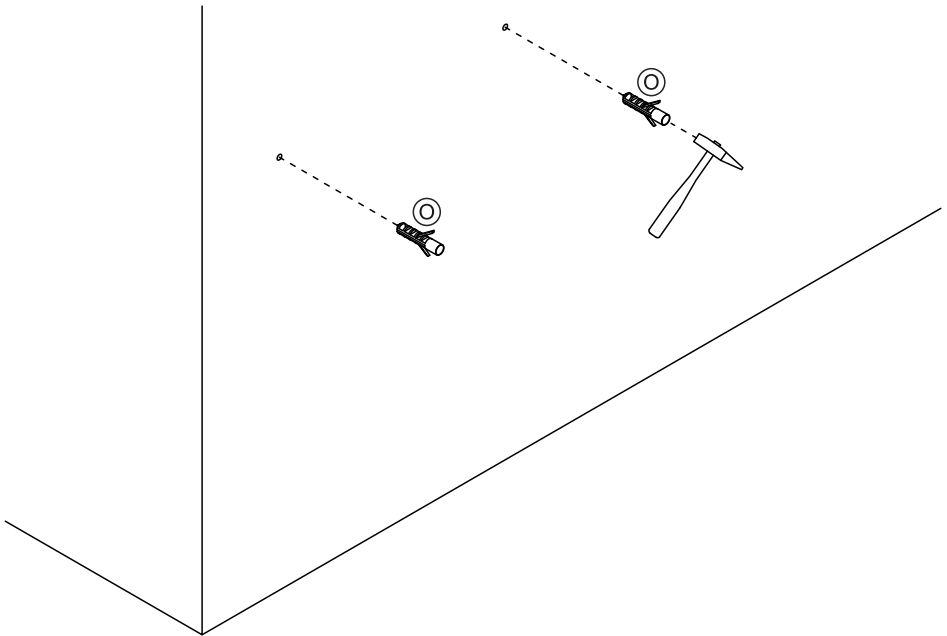
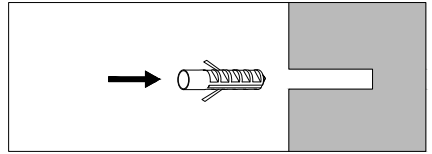
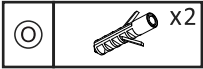

17

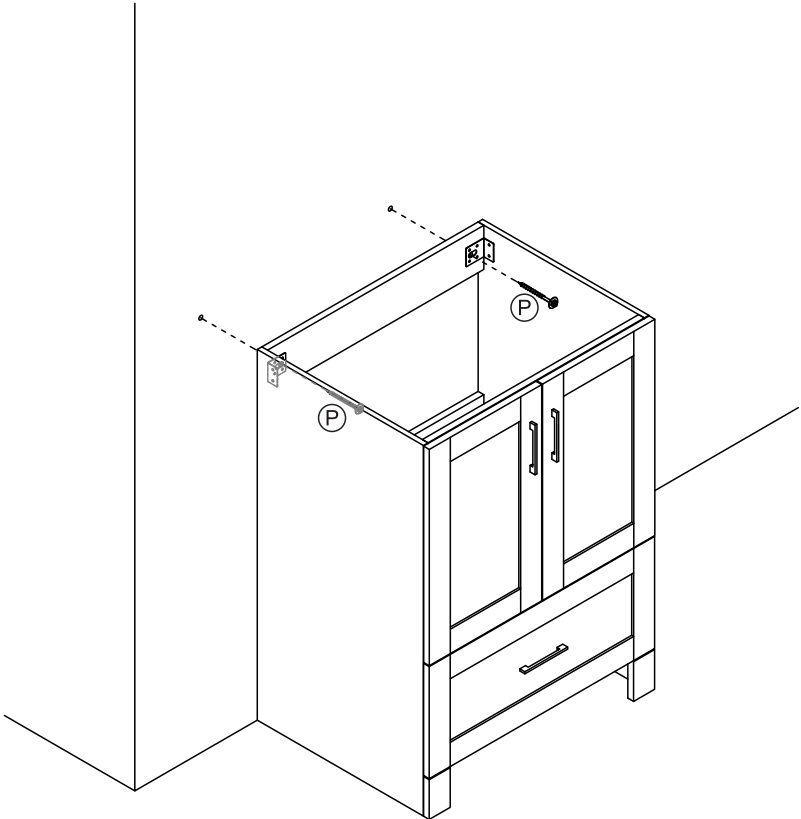

18



EN - Please use adhesive to attach the basin to the cabinet.
DE - Bitte kleben Sie das Waschbecken mit Klebstoff am Unterschrank an.
ES - Utilice adhesivo para fijar el lavabo al mueble.
FR - Veuillez utiliser de l'adhésif pour fixer la vasque à l'armoire.
IT - Si prega di utilizzare l'adesivo per fissare il lavabo al mobile.

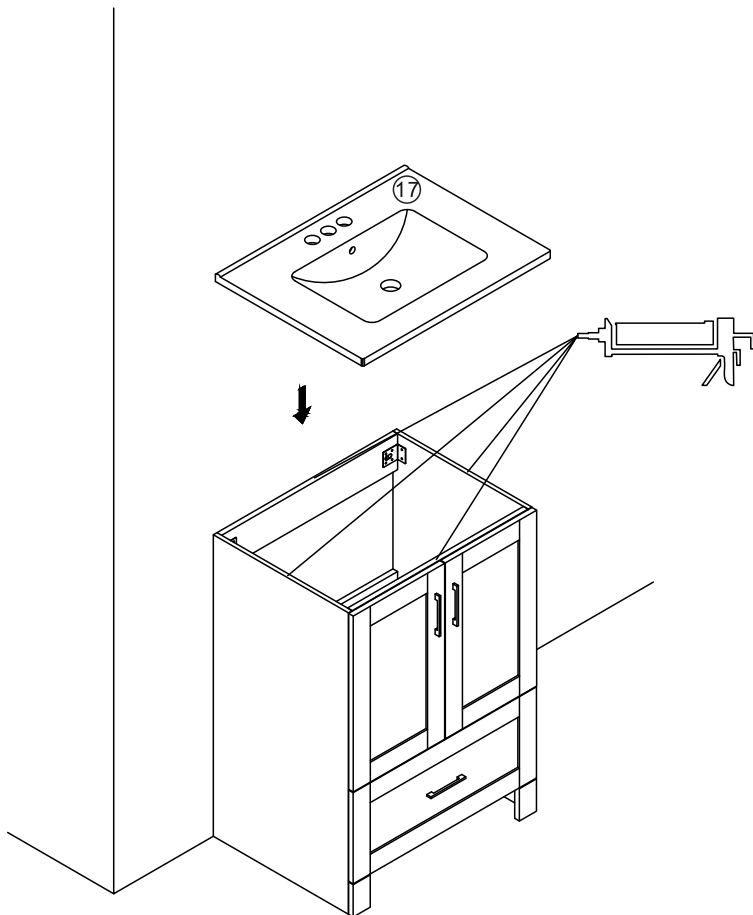

EN:Furniture Care Instructions

1. Use a soft, clean cloth or sponge to gently wipe the outer surface of the product to remove dust and dirt.
2. Avoid using chemical cleaners or harsh solvents to prevent damage to the appearance of the product.
3. Inspect the fittings (bolts, screws, nuts, etc.) every 3 months and re-tighten them every 6 months.
4. Avoid direct sunlight.

If the product shows structural damage or poses a safety hazard, stop using it until it is repaired.

5. Please seek professional help with the installation of the sink drain pipe.

DE:Pflegehinweise für Möbel

1. Benutzen Sie ein weiches, sauberes Tuch oder einen Schwamm, um behutsam die äußere Oberfläche des Geräts abzuwischen und Staub sowie Schmutz zu entfernen.
2. Vermeiden Sie die Verwendung von chemischen Reinigern oder scharfen Lösungsmitteln, um das Aussehen des Produkts nicht zu beschädigen.
3. Alle 3 Monate sollten Sie die Beschläge wie Bolzen, Schrauben, Muttern usw. überprüfen und alle 6 Monate nachziehen.
4. Es ist ratsam, direkte Sonneneinstrahlung zu vermeiden.

Sollte das Produkt strukturelle Schäden aufweisen oder ein Sicherheitsrisiko darstellen, sollte es nicht mehr verwendet werden, bis es repariert ist.

5. Bitte holen Sie sich professionelle Hilfe bei der Installation des Abflussrohrs.

ES:Instrucciones para el cuidado de los muebles

1. Utilizar un paño o una espuma suave y limpia para limpiar ligeramente la superficie exterior del producto y eliminar el polvo y la suciedad.
2. Evitar el uso de limpiadores químicos o disolventes fuertes para evitar dañar la apariencia del producto.
3. Comprobar los herrajes (pernos, tornillos, tuercas, etc.) cada 3 meses y volver a apretarlos cada 6 meses.
4. Evitar la luz solar directa.

Si el producto presenta daños estructurales o posibilidad de peligro para la seguridad, deja de utilizarlo hasta que sea reparado.

5. Solicite ayuda profesional para la instalación de la tubería de desagüe del fregadero.

FR:Conseils pour l'entretien des meubles

1. Utilisez un chiffon doux et propre ou une éponge pour essuyer délicatement la surface extérieure du produit afin d'éliminer la poussière et la saleté.
 2. Évitez l'utilisation de produits chimiques de nettoyage ou de solvants agressifs afin de préserver l'apparence du produit.
 3. Inspectez les raccords (boulons, vis, écrous, etc.) tous les 3 mois et resserrez-les tous les 6 mois si nécessaire.
 4. Évitez l'exposition directe aux rayons du soleil.
- Si le produit présente des dommages structurels ou un risque pour la sécurité, cessez de l'utiliser jusqu'à ce qu'il soit réparé.
5. Pour l'installation du tuyau d'évacuation de l'évier, veuillez solliciter l'assistance d'un professionnel

IT:Istruzioni per la Cura dei Mobili

1. Utilizzare un panno morbido, pulito o una spugna per pulire delicatamente la superficie esterna del prodotto e rimuovere polvere e sporco.
 2. Evitare l'uso di detergenti chimici o solventi aggressivi per prevenire danni all'aspetto del prodotto.
 3. Controllare le ferramenta (bulloni, viti, dadi, ecc.) ogni 3 mesi e serrarli nuovamente ogni 6 mesi.
 4. Evitare la luce diretta del sole.
- Se il prodotto mostra danni strutturali o rappresenta un pericolo per la sicurezza, smettere di usarlo fino a quando non viene riparato.
5. Rivolgersi a un professionista per l'installazione del tubo di scarico del lavandino.

EN



If you are not entirely satisfied with your purchase, please feel free to contact us using the following steps:

1. Go to Your Orders.
2. Find your order in the list.
3. Select Problem with order.
4. Choose your topic from list displayed.
5. Select Contact seller.

Please contact us at: info@yaheetech.shop

DE



Sollten Sie mit Ihrem Kauf nicht zufrieden sein, nehmen Sie bitte in folgenden Schritten mit uns Kontakt auf:

1. Gehen Sie auf die Bestellseite
2. Suchen Sie Ihre Bestellung in der Bestellliste
3. Schildern Sie das Problem mit der Bestellung
4. Thema aus der angezeigten Liste auswählen
5. Kontakt mit dem Verkäufer aufnehmen.

Kontaktieren Sie uns unter: info@yaheetech.shop

ES



Si no está totalmente satisfecho con su compra, no dude en ponerse en contacto con nosotros siguiendo las siguientes instrucciones:

1. Vaya a la lista de sus ordenes de compra.
2. Localice su pedido en la lista.
3. Seleccione el problema en el pedido.
4. Elija un tema de la lista que se muestra.
5. Seleccione Contactar con el vendedor.

Póngase en contacto con nosotros en: info@yaheetech.shop

FR



Si vous n'êtes pas satisfait de votre achat, veuillez nous contacter en procédant comme suit :

1. Allez sur "Vos commandes"
2. Trouvez votre commande dans la liste.
3. Cliquez sur "Signaler un problème"
4. Sélectionnez une catégorie dans la liste déroulante.
5. Cliquez sur "Contactez le vendeur"

Veuillez nous contacter à l'adresse suivante : info@yaheetech.shop

IT



Se non siete soddisfatti di questa esperienza dello shopping, non esitate a contattarci per i seguenti passaggi:

1. Vai ai tuoi ordini.
2. Selezionare "l'ordine interessato".
3. Selezionare il problema con l'ordine.
4. Scegli il tuo argomento dalla lista visualizzata.
5. Selezionare "contatta il venditore".

Contattaci all'indirizzo: info@yaheetech.shop