

# Assembly Directions for Rectangular Picnic Table

#PRPT2872

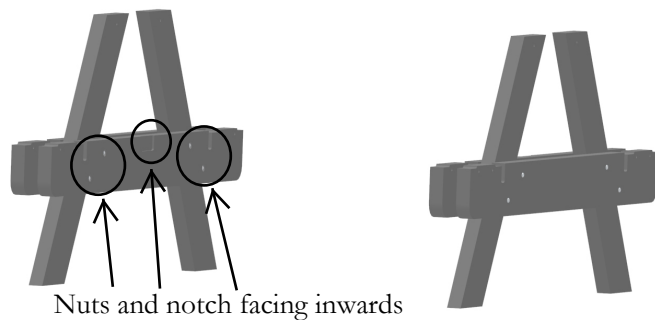

**Step #1** Place legs side by side,  
ensuring that nuts are facing inwards

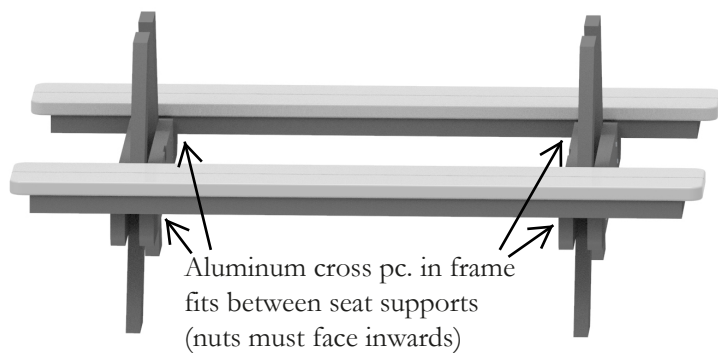

**Step #2** Place seats onto supports while aligning  
aluminum support braces on underside of  
seat between seat supports. Fasten using  
(2) 5/16" x 5" bolts (w/ nuts  
facing inward).

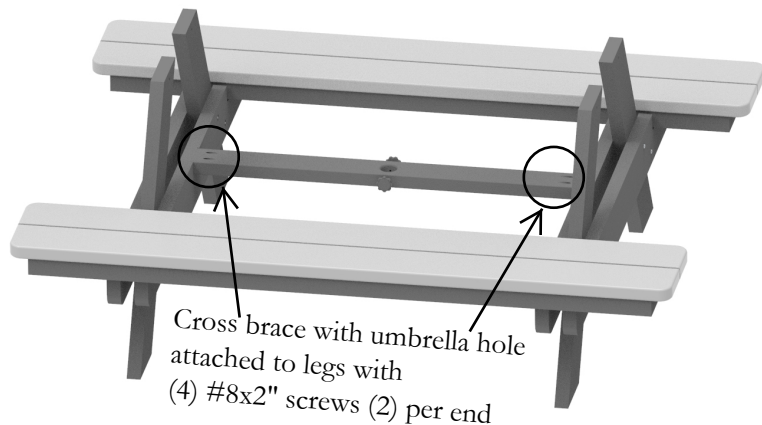
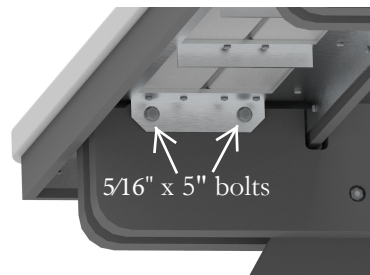

**Step #3** Attach cross pc. with umbrella hole  
to legs with (4) #8x2" screws (2) per end  
(if using umbrella, attach knobs to cross pc.)

**Step #4** Place top onto legs while aligning aluminum braces on underside of table top between legs.  
Fasten with (2) 5/16"x2" bolts per end (nuts facing inwards)

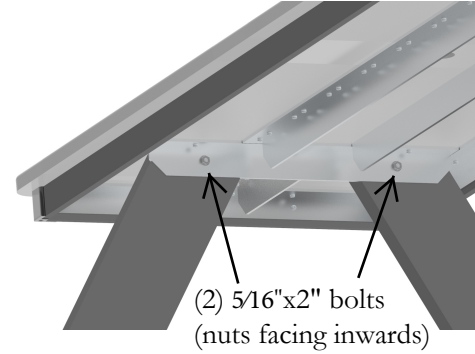

**Step #5** Attach (4) angle braces to all (4) legs and top with (1) #8 x 1 1/2" screw and (2) #8 x 5/8" screws per brace

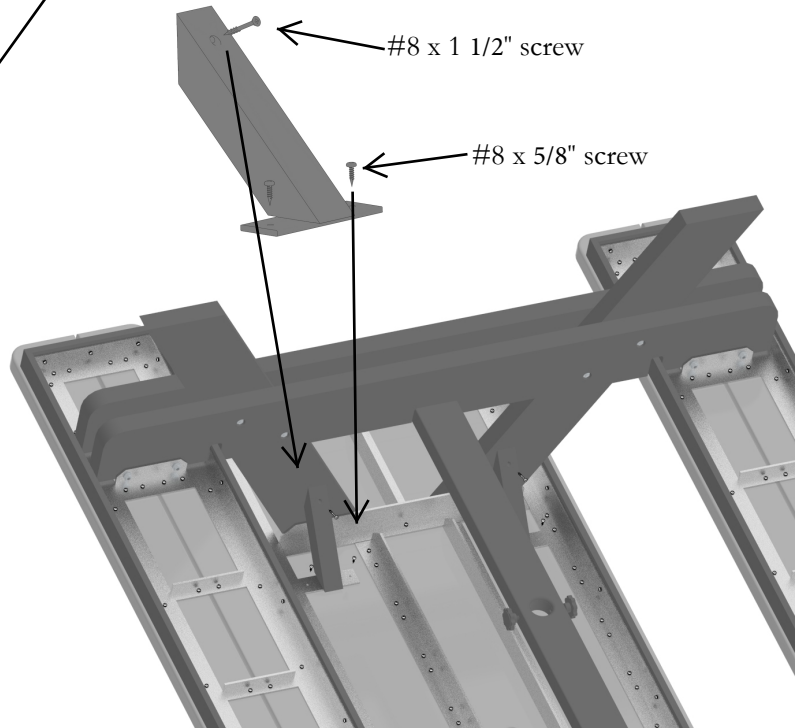
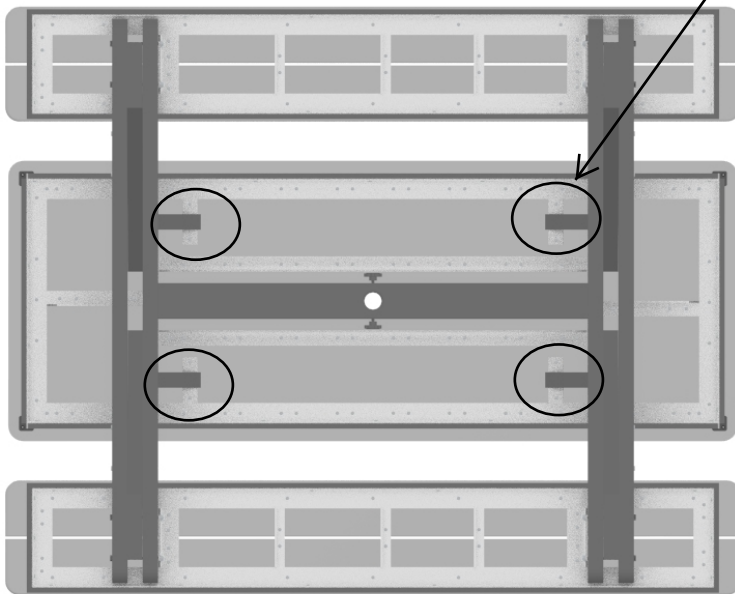

**PACKAGE CONTENTS**

- 2 Legs
- 2 Seats
- 2 Seat Supports
- 1 Cross Brace
- 1 Top
- 4 Angle Braces
- 1 Hardware Package

**HARDWARE PACKAGE**

- 8 5/16" x 5" Hex Bolts
- 4 5/16" x 2" Allen Head Bolts
- 12 5/16" Flange Nuts
- 4 #8 x 2" Screws
- 4 #8 x 1 1/2" Screws
- 8 #8 x 5/8" Screws
- 2 Umbrella Holder Knobs
- 1 Allen Wrench

**TOOLS NEEDED:**

- Hammer
- 1/2" Wrench
- Allen Wrench (Included)

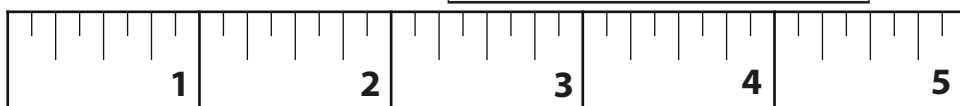

Use to measure bolts

