

| Coffee Table

V1.0

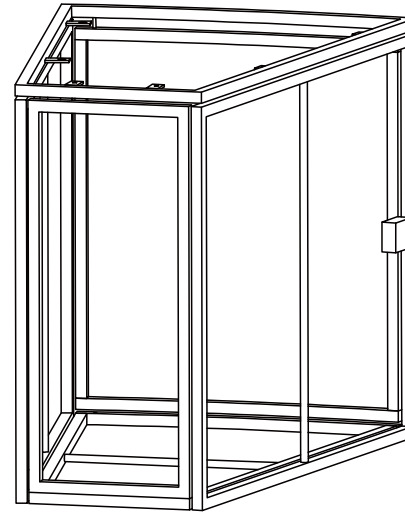
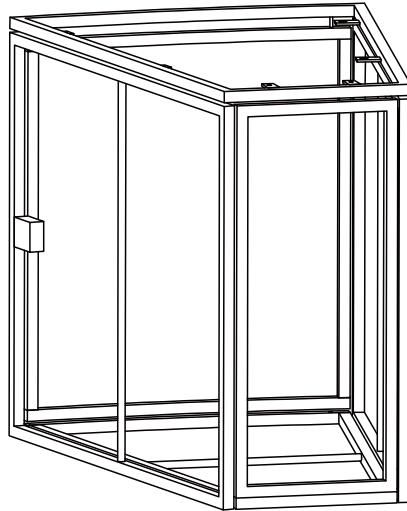

Assembly Instruction – Please keep properly for future reference.

If you find any missing boxes, damaged parts, or accessory shortages, please contact the customer service team of your purchasing channel immediately. We will resolve the issue as quickly as possible.

CONTACT US

- In order to receive assistance more quickly, please provide

THE FOLLOWING INFORMATION:

- Order number
- Purchase platform
- Purchase date
- Detailed description of the issue along with photos (if applicable)

Important – Please read these instructions carefully before starting the installation.

EN

CUSTOMER SERVICE GUIDE

Thank you for choosing our product! We are committed to providing you with excellent service. If you find any missing parts, damaged packaging, or product damage after receiving all packages, please follow the steps below to quickly contact our customer service team. We will do our best to resolve your issue.

1. Missing Parts

Verify Parts:

1. Refer to the “Parts List” in the manual to verify the name, specifications, and quantity of the missing parts.
2. Take a clear photo of the parts list and mark the missing parts with detailed information, e.g., “Missing 5 pieces of M6x30mm screws.”

Contact Us:

· By Email:

Send an email with the subject line “Missing Parts Issue.” Include the following in the email:

- A description of the missing parts and a photo of the parts list.
- Order details (order number, purchase platform, purchase date).

2. Product or Packaging Damage

If it affects normal use:

Steps:

1. Take clear photos or videos showing the damaged parts and the extent of the damage (multi-angle shots are recommended).
2. Email the photos/videos along with other details with the subject line “Product Damage Issue.”

Resolution:

After verification, we will arrange for a replacement part, product exchange, or refund as quickly as possible.

If it does not affect normal use:

Steps:

1. Contact our customer service team .
2. Provide a description of the damage and include relevant photos or videos.

Resolution:

We will provide repair guidance or an appropriate compensation plan based on the specific situation.

Helpful Tips

To process your issue efficiently, please prepare the following information:

- Order details (order number, purchase platform, purchase date).
- Clear photos or videos.
- We are committed to providing quick and professional solutions, no matter the size of the issue, to ensure your satisfaction.

Thank you for your trust and support! We hope you enjoy using our product!

Coffee table

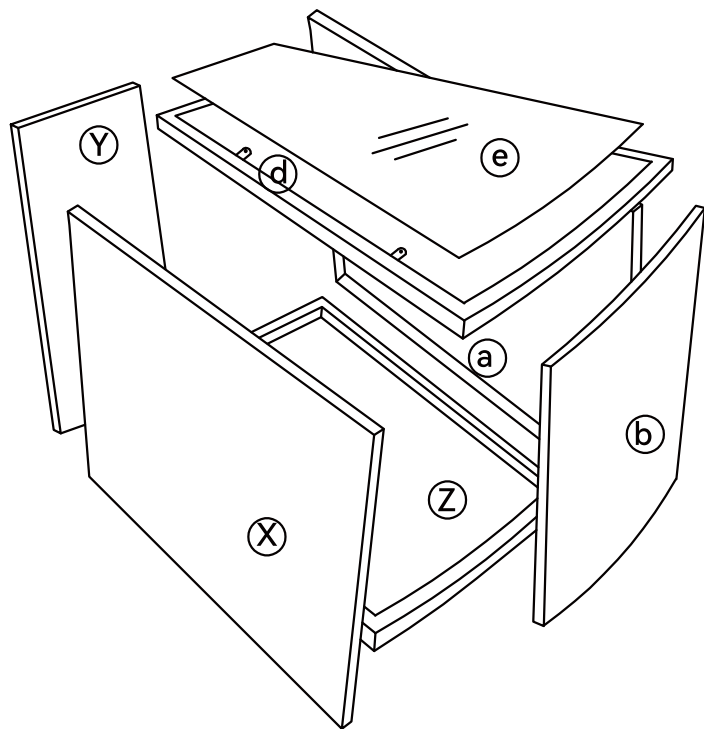

Main structure accessories

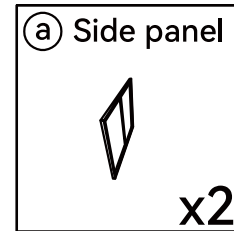
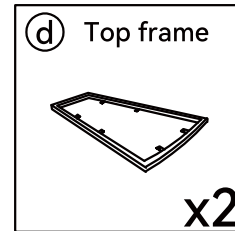
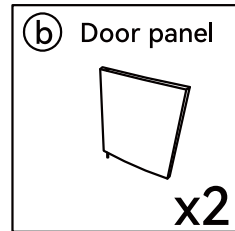
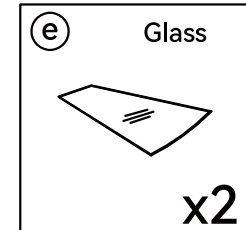
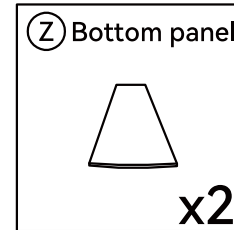
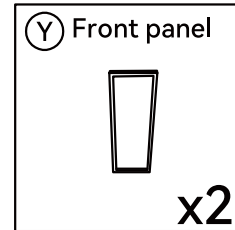
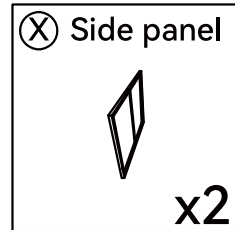



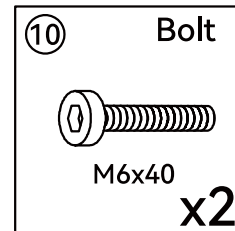
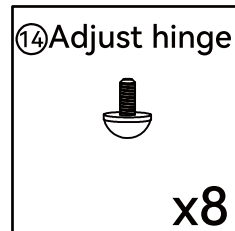
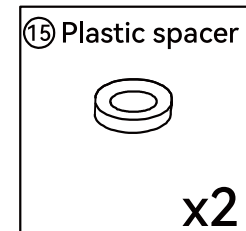
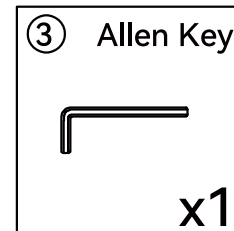
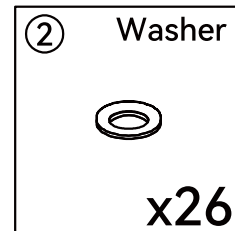
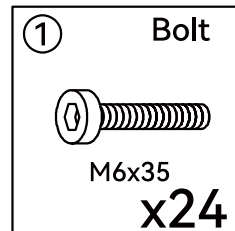

Hardware parts

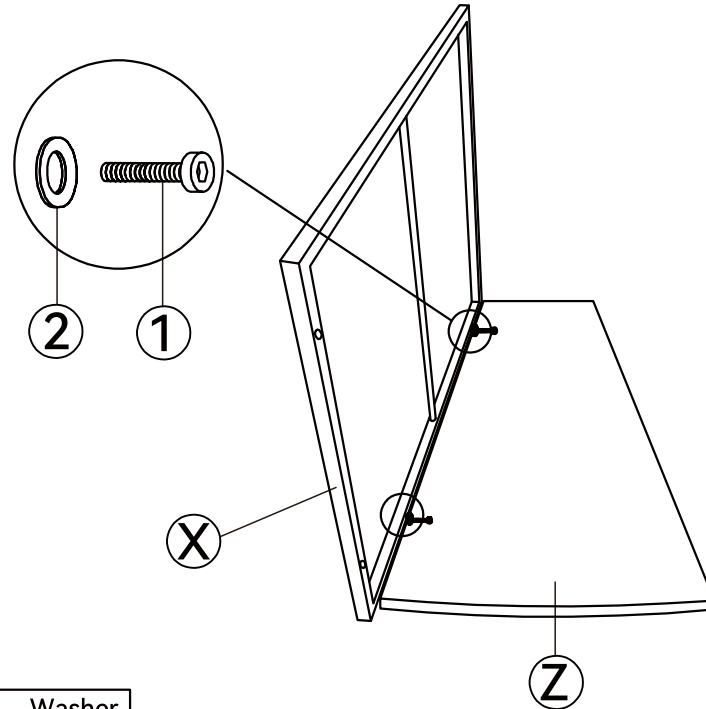

Main structure accessories

STEP 1



ⓧ Side panel	Ⓩ Bottom panel	① Bolt	② Washer
		 M6x35	
x2	x2	x4	x4



Note: Do not fully tighten the screws.

Use screw (1) and washer (2) to connect part (Z) and part (X).

Main structure accessories

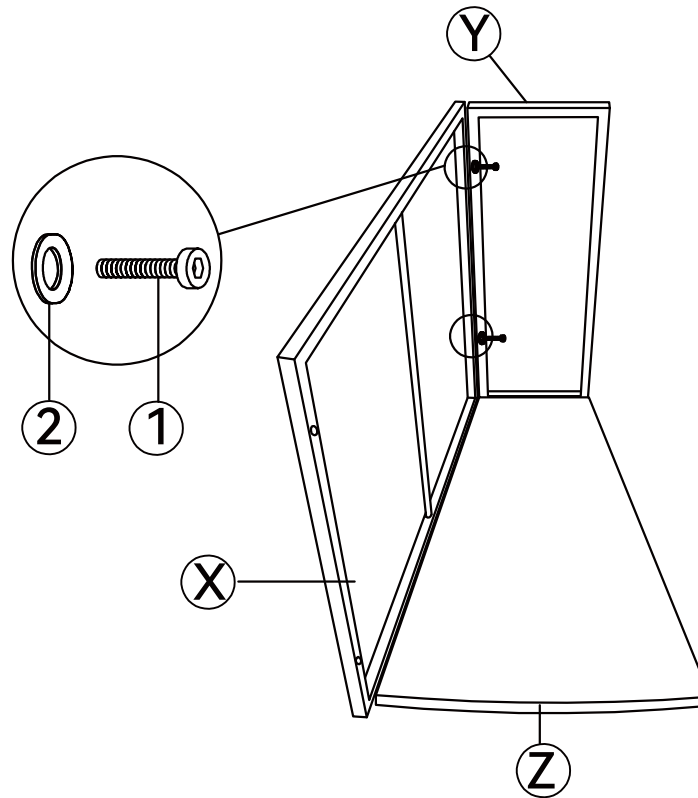
STEP 2



Ⓨ Front panel  x2	① Bolt  M6x35 x4	② Washer  x4
--	--	---

Use screw (1) and washer (2) to connect part (Y) and part (X).

Main structure accessories

STEP 3

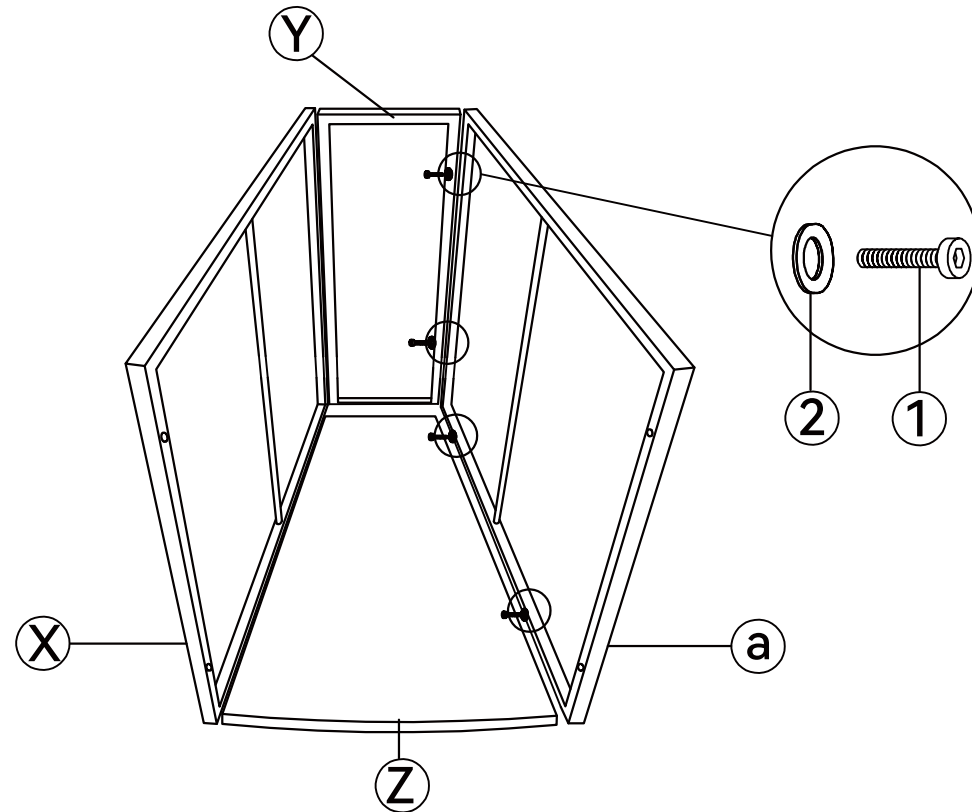





(a) Side panel x2	(1) Bolt M6x35 x8	(2) Washer x8
----------------------	-------------------------	------------------

Use screw (1) and washer (2) to connect part (Y), part (Z), and part (a).

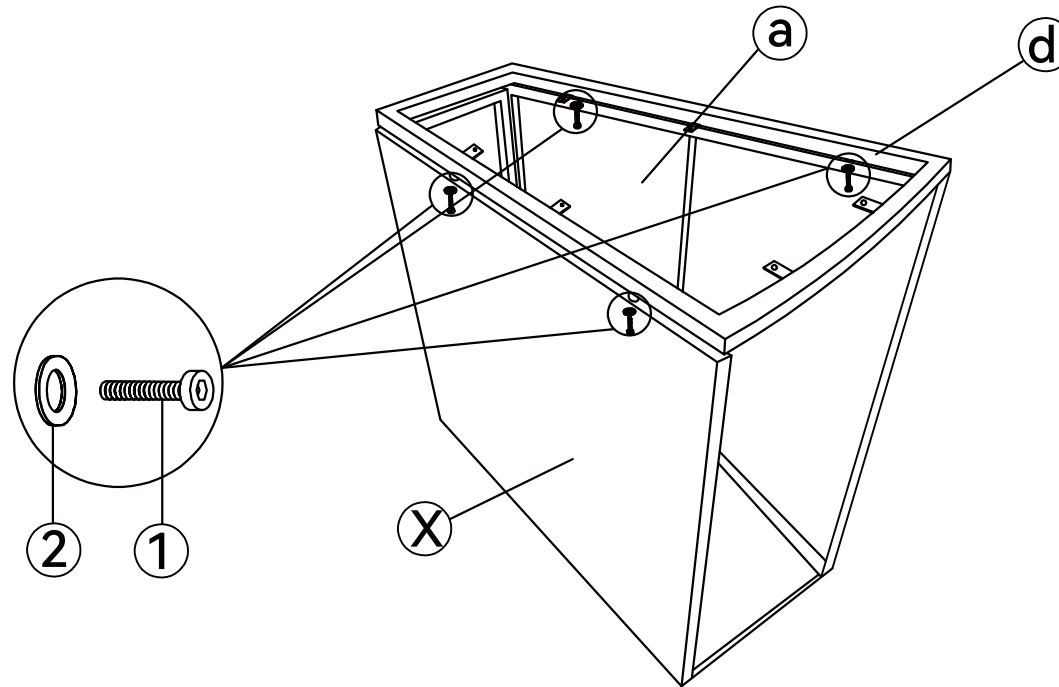
Main structure accessories

STEP 4



④ Top frame  x2	① Bolt  M6x35 x8	② Washer  x8
--	--	---

Use screw (1) and washer (2) to connect part (X), part (a), and part (d).

Main structure accessories

STEP 5

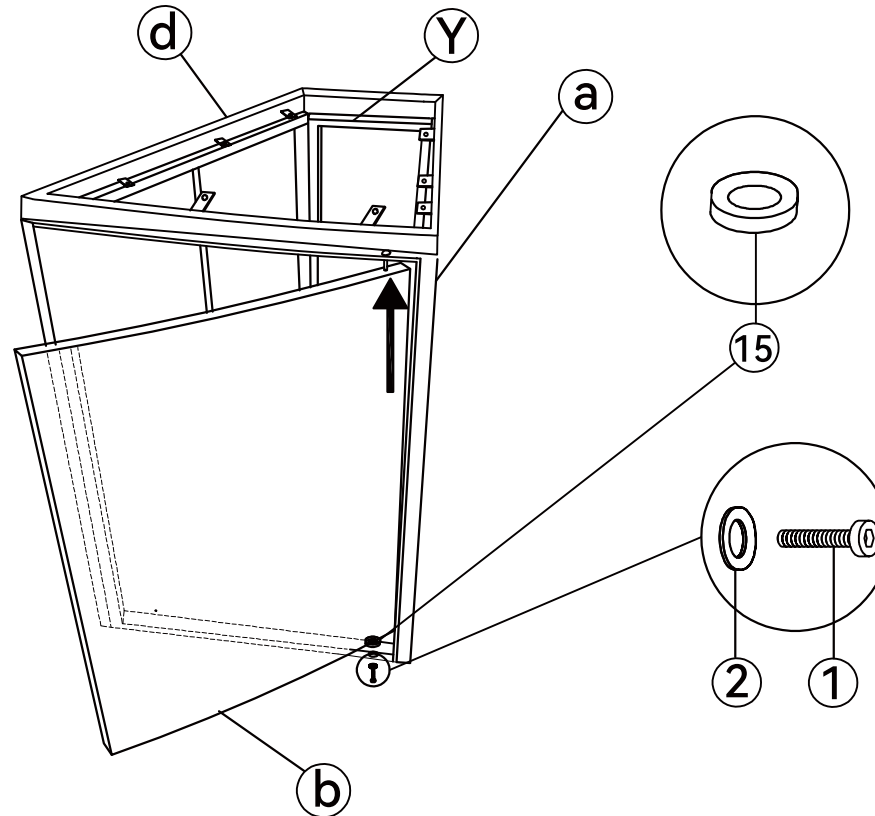



(b) Door panel x2	(10) Bolt M6x40 x2	(2) Washer x2	(15) Plastic spacer x2
----------------------	--------------------------	------------------	---------------------------

Use screw (10), washer (2), and plastic washer (4) to connect part (Z), part (b), and part (d).

Main structure accessories

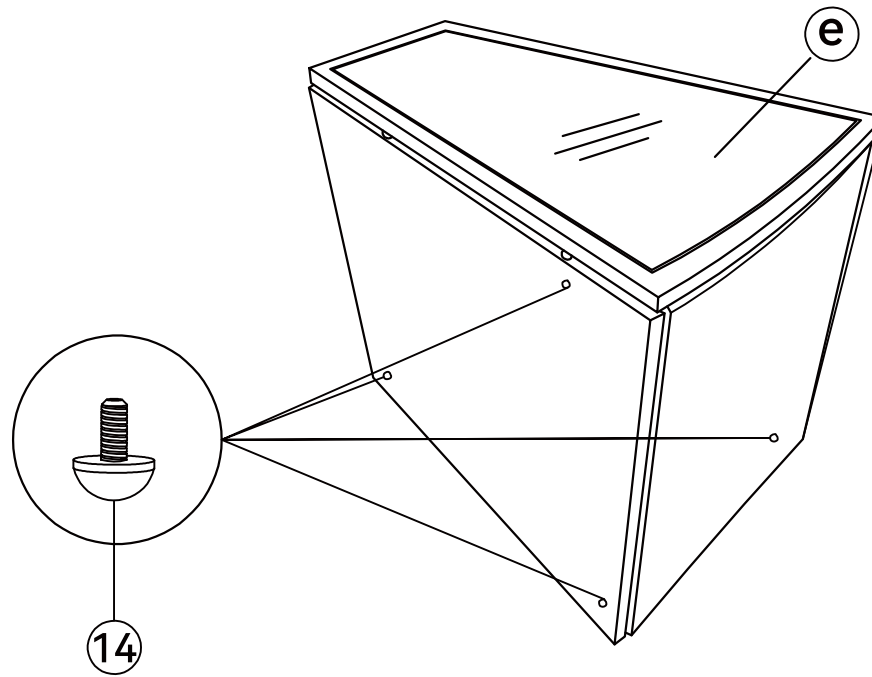
STEP 6



e Glass	14 Adjust hinge
 x2	 x8

Install the adjustable foot pad onto part (14) to complete the connection.
Tighten the screws in this step.