

ASSEMBLY INSTRUCTIONS

STEP 1

Place TABLE TOP (A) top side down on a clean smooth surface. Screw each LEG (C) into circular collars on corners of TABLE TOP (A). Tighten clockwise until fully secured.

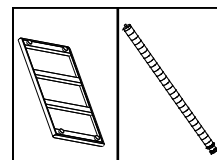

A (1)

C (4)

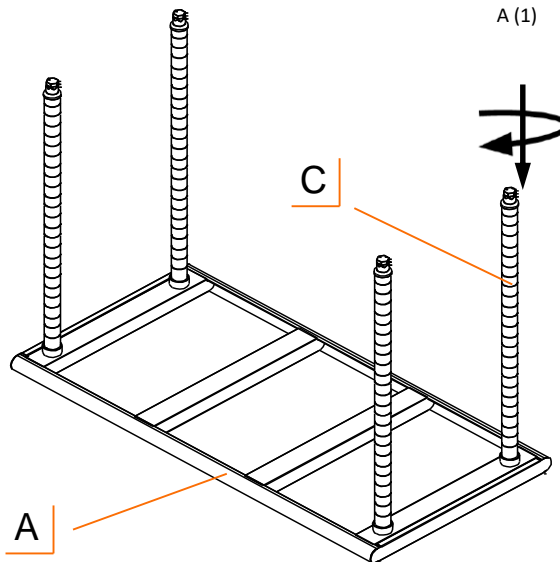

STEP 2

Slide SHELF (B) carefully top side down over each LEG (C) at same time, until it rests on the bottom of TABLE TOP (A).

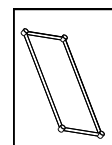

B (1)

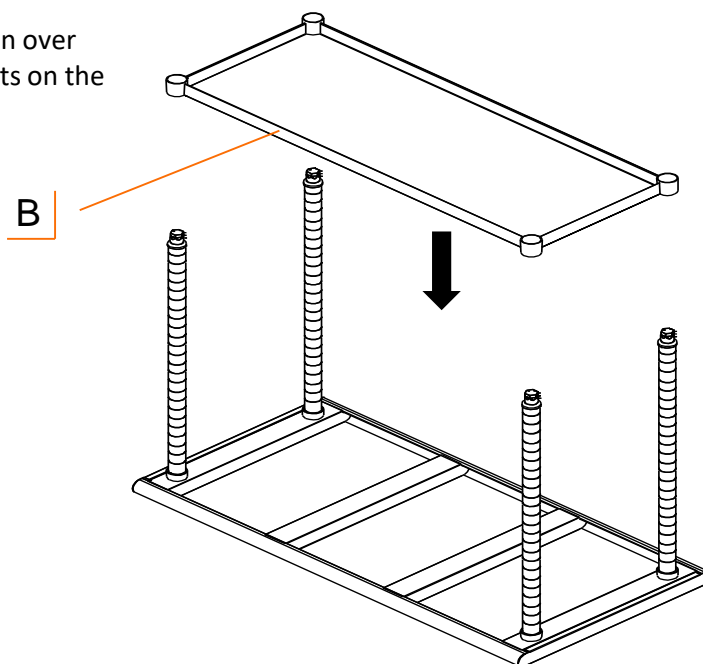

ASSEMBLY INSTRUCTIONS

STEP 3

Note that each LEG (C) has slight horizontal line indentations. Each SLIP SLEEVE (D) has raised horizontal lines inside designed to lock them in place on LEG (C).

On LEG (C), place 1 pair of SLIP SLEEVES (D) at the desired level. Make sure arrow points down and word "TOP" is upside-down. Slide pair of SLIP SLEEVES (D) up until you hear a click to confirm pair is locked onto LEG (C).

Do this at the same height for each LEG (C).

Note: For safety and stability, place the SLIP SLEEVES (D) no lower than the 12 indentations from the feet leveler. With additional shelves, one shelf should always be on the lower half of the legs.

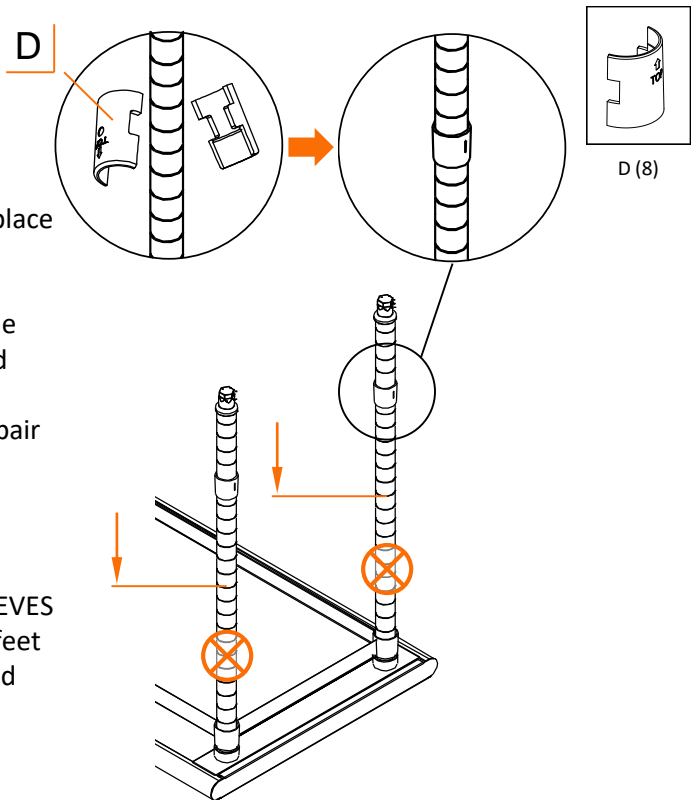

STEP 4

With another person's help, slowly and carefully turn Table right-side up, making sure to hold SHELF (B), so it does not slam down onto the SLIP SLEEVES (D) .

Press each corner of SHELF (B) down over SLIP SLEEVES (D) to secure it. Press tightly until each corner collar is over SLIP SLEEVES (D).

Note: Use a rubber mallet, if needed, to secure SHELF (B).

Adjust Feet Levelers until Table is stable and level.

