

ASSEMBLY INSTRUCTION

ITEM # 7663-QUEEN / 7665-QUEEN / 7666-QUEEN

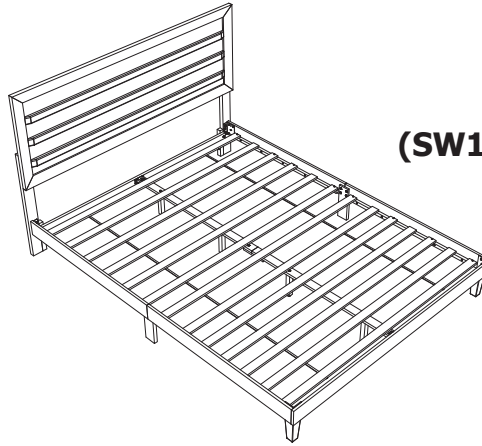





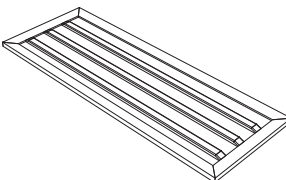
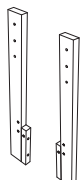
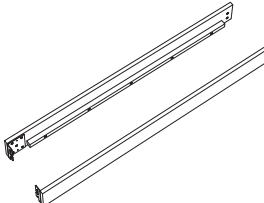
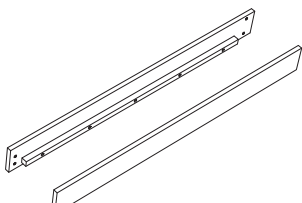
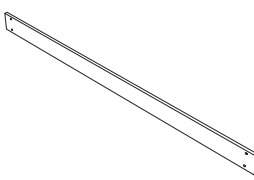
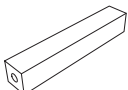
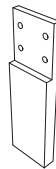
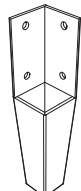
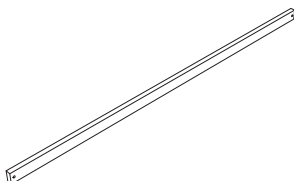
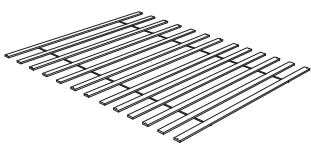
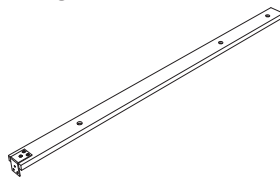
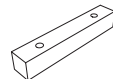

(SW1890QS - QUEEN)

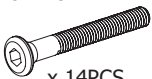
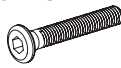
PART LIST

<p>1. HEADBOARD PANEL</p>  <p style="text-align: center;">x 1PC</p>	<p>2. HEADBOARD LEG (L/R)</p>  <p style="text-align: center;">x 2PCS</p>	<p>3. SIDE BED RAIL A (L/R)</p>  <p style="text-align: center;">x 2PCS</p>	<p>4. SIDE BED RAIL B (L/R)</p>  <p style="text-align: center;">x 2PCS</p>
<p>5. FOOTBOARD PANEL</p>  <p style="text-align: center;">x 1PC</p>	<p>6. CENTER RAIL LEG</p>  <p style="text-align: center;">x 4PCS</p>	<p>7. SIDE RAIL LEG</p>  <p style="text-align: center;">x 2PCS</p>	<p>8. LEG</p>  <p style="text-align: center;">x 2PCS</p>
<p>9. STRETCHER RAIL</p>  <p style="text-align: center;">x 1PC</p>	<p>10. ROLL SLAT</p>  <p style="text-align: center;">x 1SET</p>	<p>11. CENTER RAIL</p>  <p style="text-align: center;">x 2PC</p>	<p>12. CENTER RAIL JOINTER</p>  <p style="text-align: center;">x 1PCS</p>

HARDWARE LIST (IN ACTUAL SIZE/SCALE FOR REFERENCE)

<p>A. JCBC BOLT M6 x 40mm</p>  <p style="text-align: center;">x 14PCS</p>	<p>B. JCBC BOLT M6 x 18mm</p>  <p style="text-align: center;">x 20PCS</p>	<p>C. SPRING WASHER M6</p>  <p style="text-align: center;">x 34PCS</p>	<p>D. FLAT WASHER M6</p>  <p style="text-align: center;">x 34PCS</p>	<p>E. CSK SCREW M4 X 25mm</p>  <p style="text-align: center;">x 16PC</p>
<p>F. LEVELER</p>  <p style="text-align: center;">x 4PC</p>	<p>G. ALLEN KEY M4</p>  <p style="text-align: center;">x 1PC</p>			

Read this instructions carefully.

See hardware and furniture part list for guidance. Be sure all parts are complete before you assemble. Place all wooden furniture parts on a clean and flat soft surface to prevent from being scratched. Follow the figure so start assembling.

CAUTIONS :

1. DO NOT **Fully -Tighten** the bolt until all bolt are ready for assembled.
 2. DO NOT **Over-Tighten** the bolt to avoid damaging the thread.
 3. Keep all hardware parts stay away from children.
- NOTE : THE LIST AND QUANTITY SHOWN ARE FOR 1 UNIT ASSEMBLY.

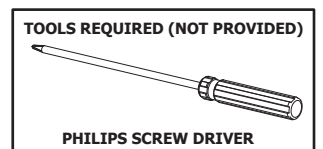

ITEM # 7660-QUEEN / 7661-QUEEN / 7662-QUEEN

STEP 1

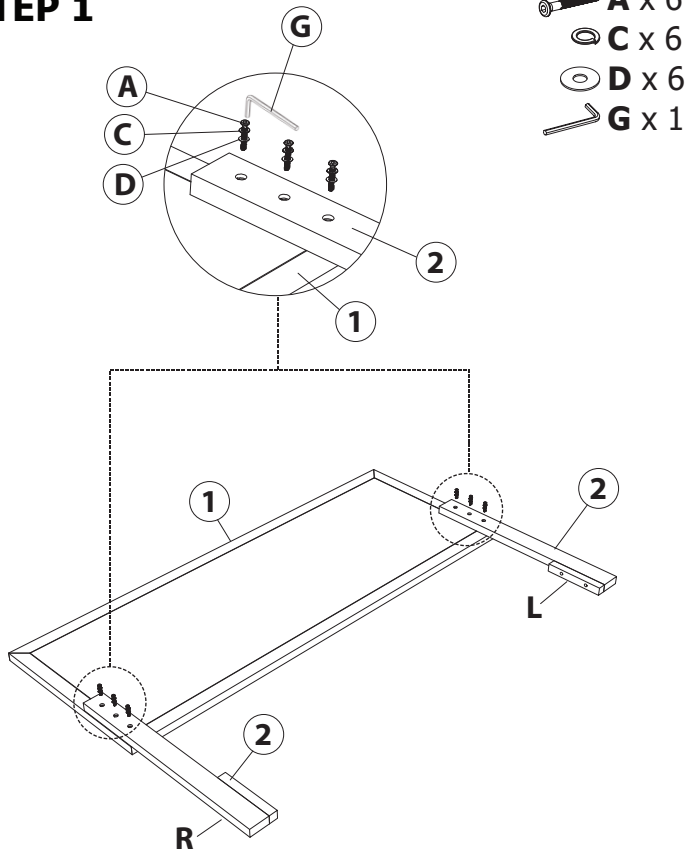

Place Headboard Leg (2) on the bottom Right (R) and Left (L) side of the Headboard Panel (1) and attach by inserting M6x40mm Bolt (A), Spring Washer (C), and Flat Washer (D). Then tighten the bolts clockwise with Allen Key (G) until secure.

STEP 2

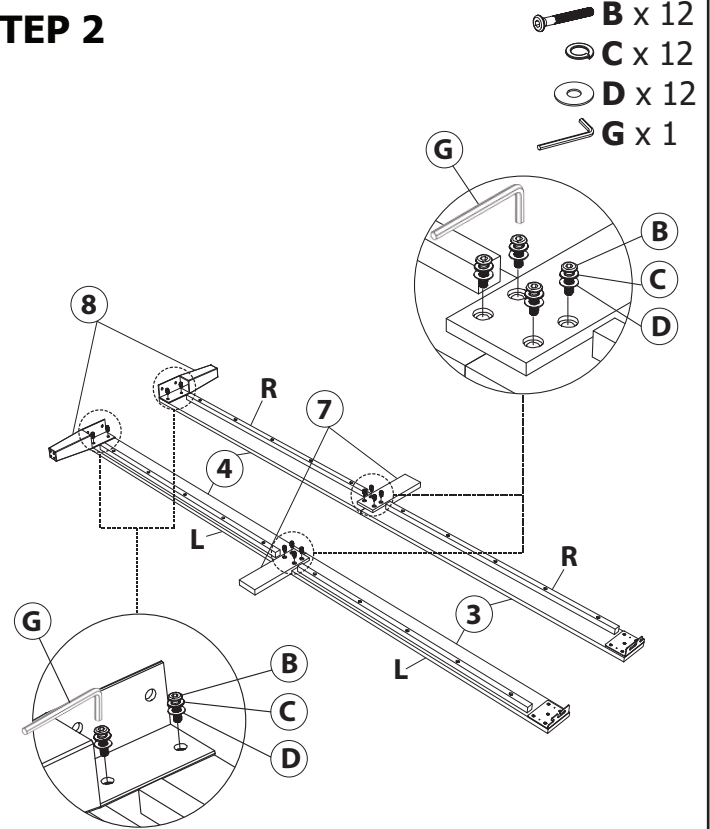

Attach the Leg (8) to end of each Right (R) & Left (L) Side Bed Rail (4) by using M6x18mm Bolt (B), Spring Washer (C), and Flat Washer (D), & tighten clockwise using Allen Key (G). Then connect both Side Bed Rails (3 & 4) by using the Side Rail Leg (7) and secure with M6x18mm Bolt (B), Spring Washer (C), and Flat Washer (D), and tighten clockwise using Allen Key (G).

STEP 3

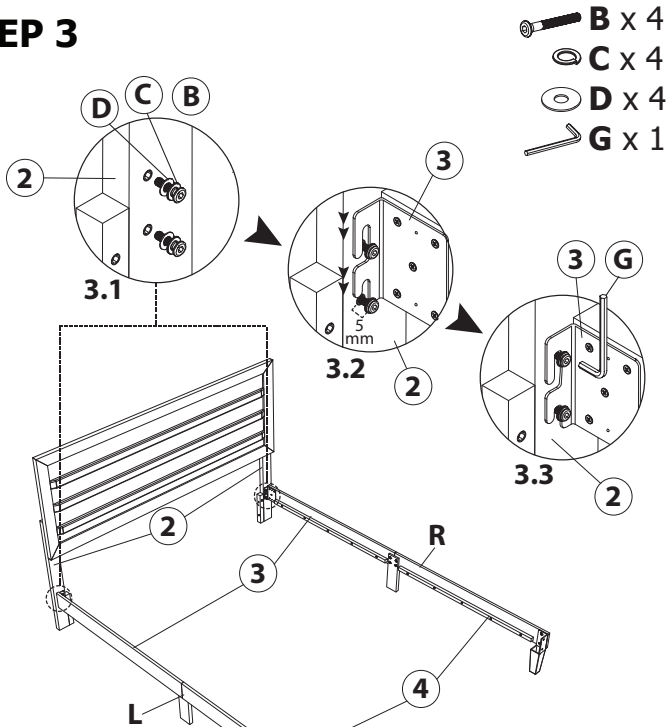

3.1
Insert M6x18mm Bolts (B) clockwise inside the thread of Headboard Leg (2) on both Left (L) & Right (R) side. Do not insert Bolts (B) all the way in, leave out about 5mm length.

3.2
Hook Siderail (3) on the M6x18mm Bolts (B) attached on Headboard Leg (2).

3.3
Tighten the Bolts (B) using Allen Key (G).



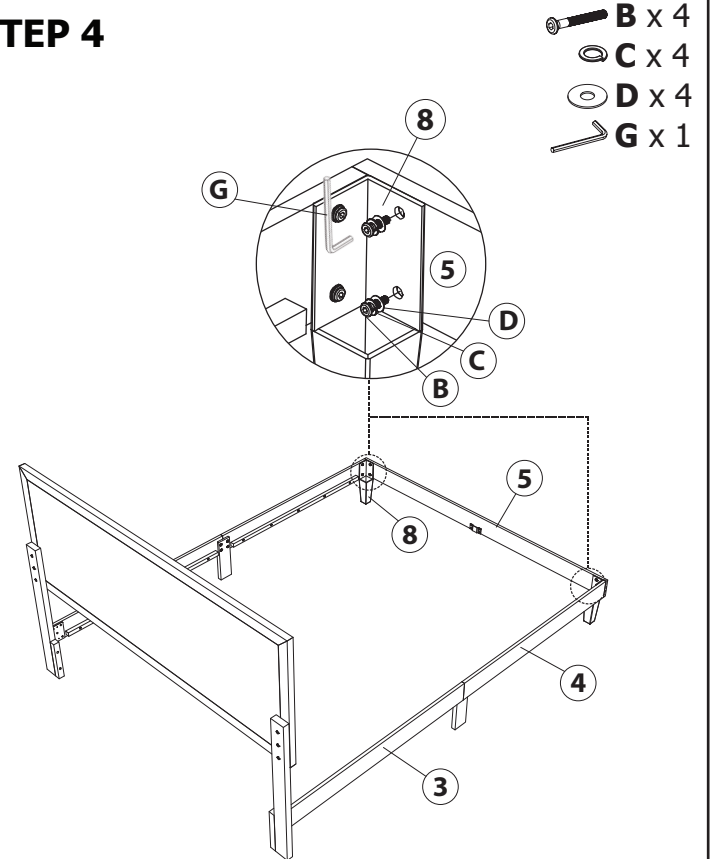

STEP 4



Attach the Footboard (5) to the Leg (8) with M6x18mm Bolts (B), Spring Washer (C), and Flat Washer (D) and tighten using the Allen Key (G).

ITEM # 7663-QUEEN / 7665-QUEEN / 7666-QUEEN



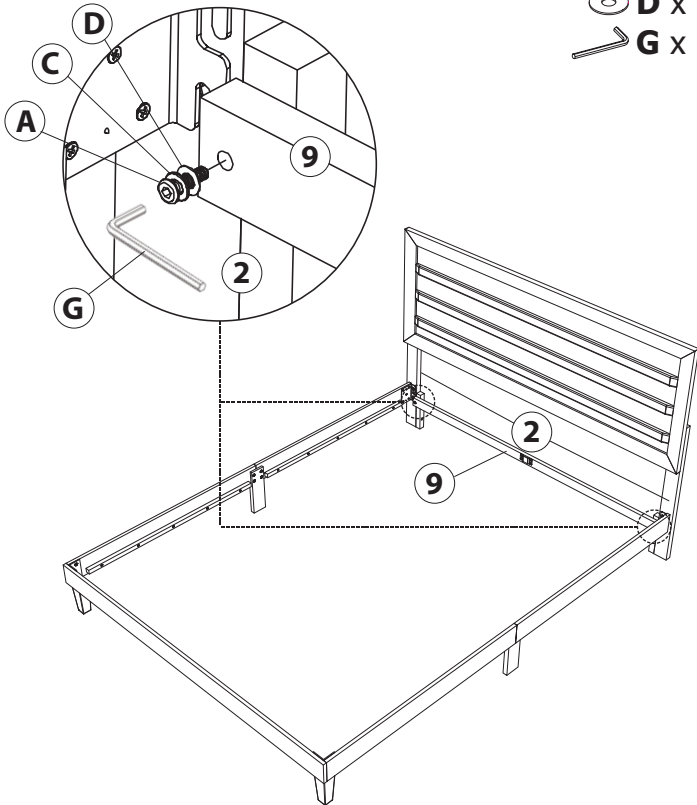

STEP 5

-  A x 2
-  C x 2
-  D x 2
-  G x 1



Attach the Stretcher Rail (9) to the Headboard Leg (2) with M6x40mm Bolt (A), Spring Washer (C), and Flat Washer (D). Then tighten the bolts clockwise using Allen Key (G) until secure.

STEP 6

-  A x 6
-  C x 6
-  D x 6
-  F x 4
-  G x 1

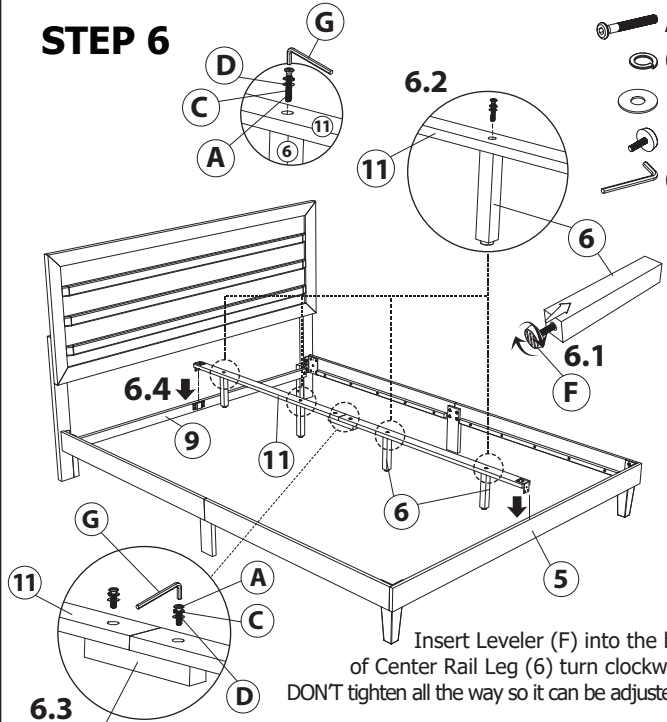

6.1 Insert Leveler (F) into the bottom of Center Rail Leg (6) turn clockwise but DON'T tighten all the way so it can be adjusted later.

6.2 Attach Center Rail Leg (6) to the bottom Center Rail (11) using M6x40mm Bolt (A), Spring Washer (C), and Flat Washer (D). Then secure the bolts clockwise using Allen Key (G).

6.3 Connect the 2 Center Rails (11) by attaching Center Rail Joints (12) using M6x40mm Bolt (A), Spring Washer (C), & Flat Washer (D). Then secure the bolts clockwise using Allen Key (G).

6.4 Insert Center Rail (11) to the bracket (provided) on Stretcher Rail (9) and Footboard Panel (5).

STEP 7

-  E x 16

NOTE:
This mark on the "Slat" marking for this side must be on the "Headboard" position.

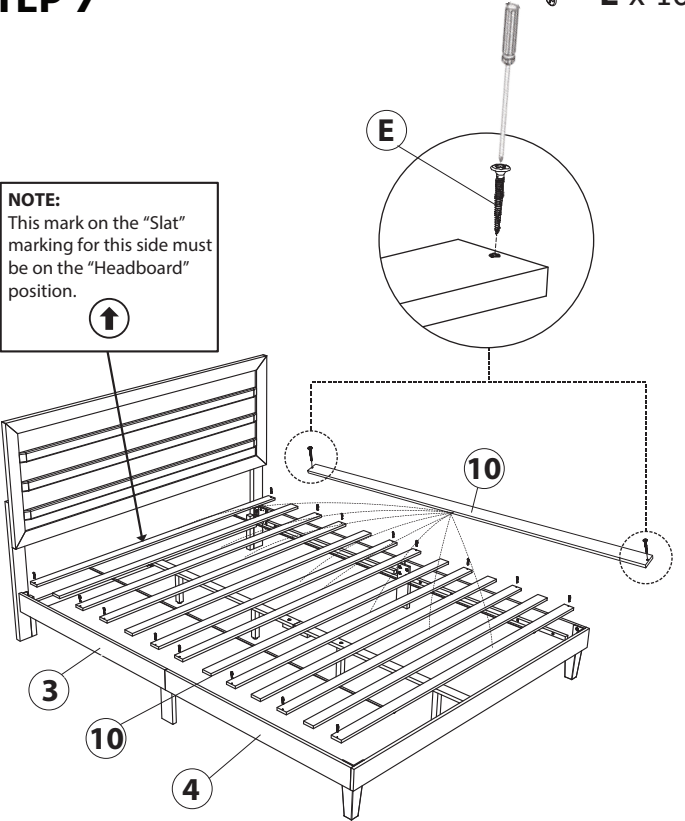

Attach Roll Slat (10) to Side Bed Rails (3 & 4) using M4x25mm Screw (E). Tighten the Screw (E) with the Phillips Screw Driver (Not Provided)

STEP 8

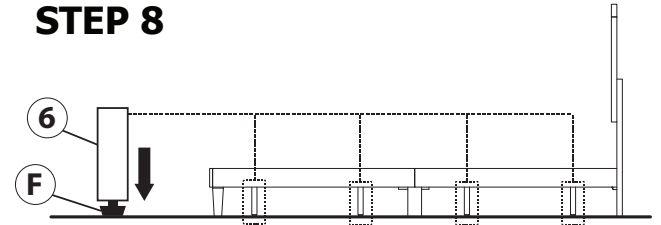

After moving the bed to preferred position, adjust the Center Rail Support Legs (6) straight to the ground.

ASSEMBLY COMPLETED

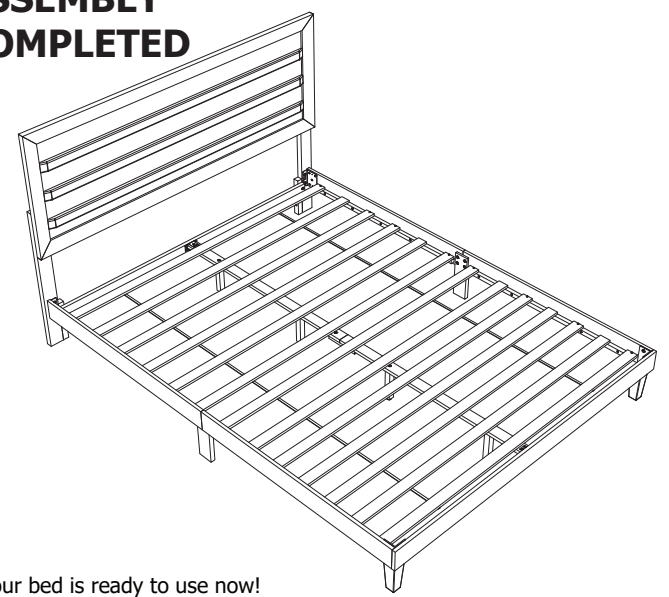

Your bed is ready to use now!
Make sure all the screw are fully tightened before using it.
DO NOT Jump or Stand on the bed.