

ASSEMBLY INSTRUCTIONS

TABLE ASSEMBLED

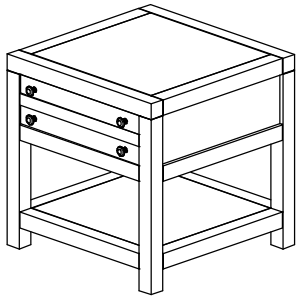

PARTS AND FITTING PACKAGING DETAIL

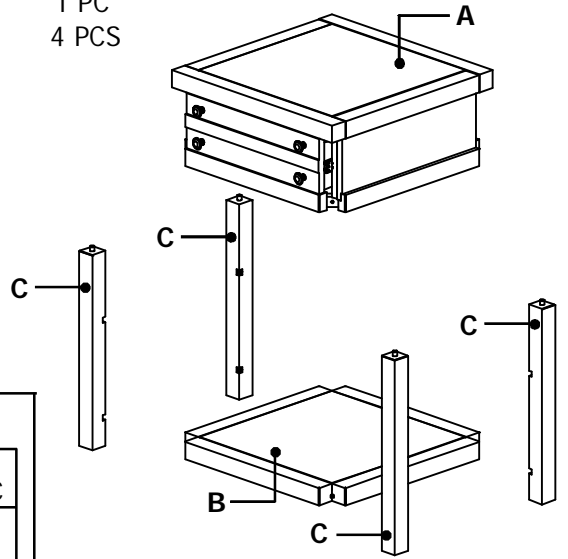

- A. SIDE TABLE BODY 1 PC
- B. SIDE TABLE SHELF 1 PC
- C. LEG 4 PCS
- HARDWARE BOX



WARNING

FOR YOUR SAFETY AND CONVENIENCE ASSEMBLY BY TWO PEOPLE IS RECOMMENDED

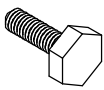
HARDWARE PACKED IN BOX

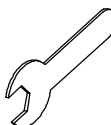
1	HEX BOLT (60MM)	8 PCS	2	LOCK WASHER	8 PCS	3	FLAT WASHER	8 PCS	4	WRENCH	1 PC
											

STEP 1 :

ATTACH LEGS (C) TO SIDE TABLE SHELF (B) USING HEX BOLTS (1), LOCK WASHERS (2) AND FLAT WASHERS (3). DO NOT TIGHTEN THE BOLTS COMPLETELY.

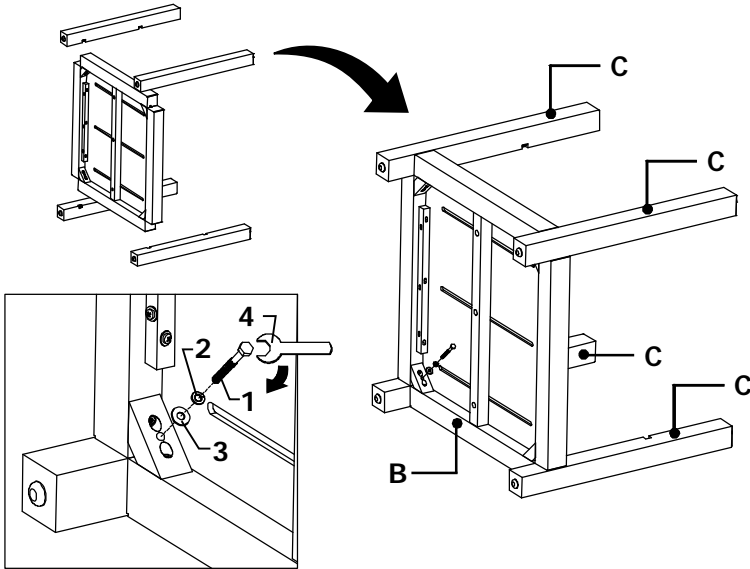

STEP 2 :

ON A CLEAN, FLAT, LEVEL SURFACE, LAY THE SIDE TABLE BODY (A) UPSIDE DOWN. ATTACH THE SHELF ASSEMBLY FOLLOWING THE ILLUSTRATION.

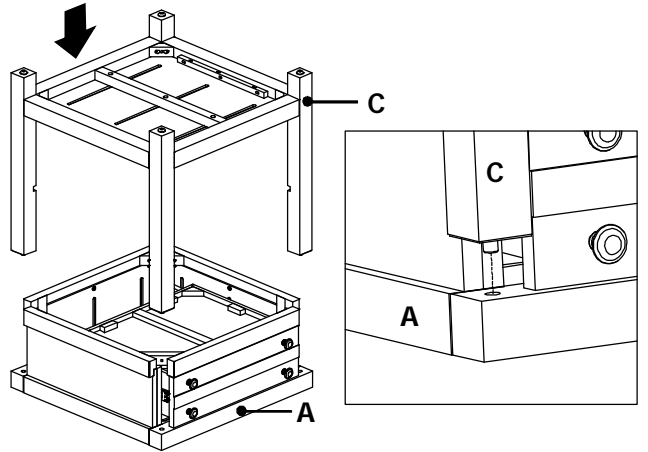

STEP 3 :

FOLLOWING THE ILLUSTRATION, ATTACH CONNECTED SHELF ASSEMBLY TO THE SIDE TABLE BODY USING HEX BOLTS, LOCK WASHERS AND FLAT WASHERS. TIGHTEN ALL BOLTS, INCLUDING ONES FROM STEP 1, COMPLETELY WITH WRENCH (4).

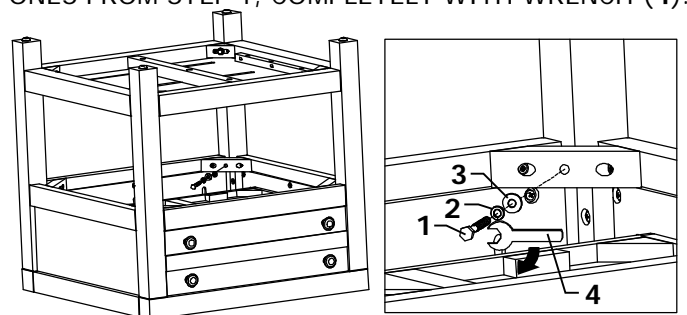

INSTRUCTIONS FOR ADJUSTING LEVELERS :

- POSITION THE TABLE IN YOUR ROOM LOCATE LEVELERS UNDER EACH LEG.
- TURN COUNTER-CLOCKWISE TO EXTEND, CLOCKWISE TO CONTRACT.
- ADJUST LEVELERS UNTIL EACH LEG IS APPLYING EQUAL UPWARD PRESSURE ON THE TABLE.

