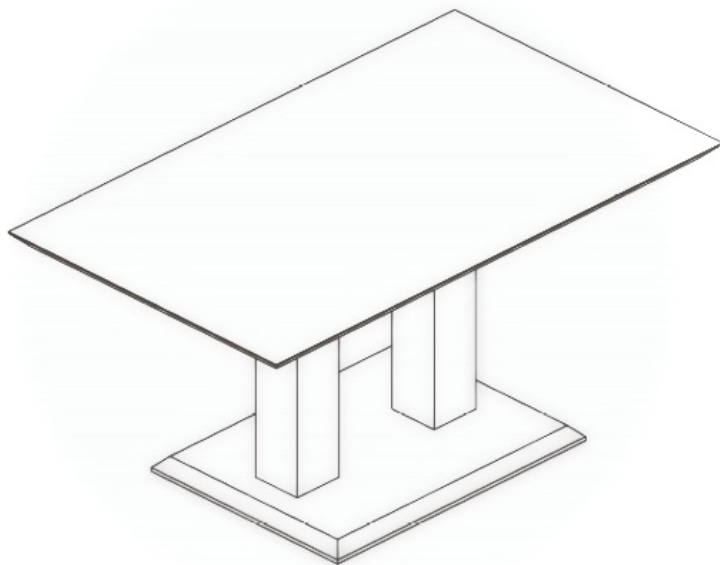

TABLE ASSEMBLY INSTRUCTIONS





OUR 1 YEAR GUARANTEE

our products come with a 1 year guarantee to give you peace of mind shopping at



WHAT THE GUARANTEE COVERS



PRE-INSERTED FIXINGS

e.g. lose metal threads



FAULTY JOINTS

e.g. legs bending



EXTERNAL FIXING FAULTS

e.g. metal discs removing from table top



STRUCTURAL INTEGRITY

e.g. the frame of the product

Important-Please read these instructions fully before starting assembly



safety and
care advice



- Check you have all the components and tools listed.

- Remove all fittings from the plastic bags and separate them into their groups.

- We do not recommend the use of power drills/drivers for inserting screws, as this could damage the unit. Only use hand screwdrivers and Allen keys.

- Keep children and animals away from the work area, small parts could cause choking if swallowed.

- Make sure you have enough space to layout the parts before starting.

- Assemble the item as close to its final position (in the same room) as possible.

- Do not overtighten the nuts to avoid causing damage to the threads.

Please check you have all the panels listed below

1 x1 Table top

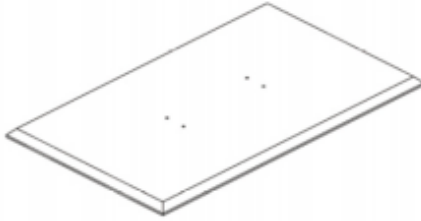

2 x2 Table legs





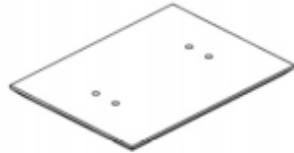

3 x1 Table base



Please check you have all the fittings listed below

Note : The quantities below are the correct amounts to complete the assembly. In some cases more fittings may be supplied than are required.

<p>A</p>  <p>M8X720mm Threaded Rod X4</p>	<p>B</p>  <p>M8mm Nut X4</p>	<p>C</p>  <p>M8X22mm Metal Washer X4</p>
<p>D</p>  <p>M14mm Box Spanner X1</p>	<p>E</p>  <p>Φ30PVC Stickers X4</p>	

Step 4

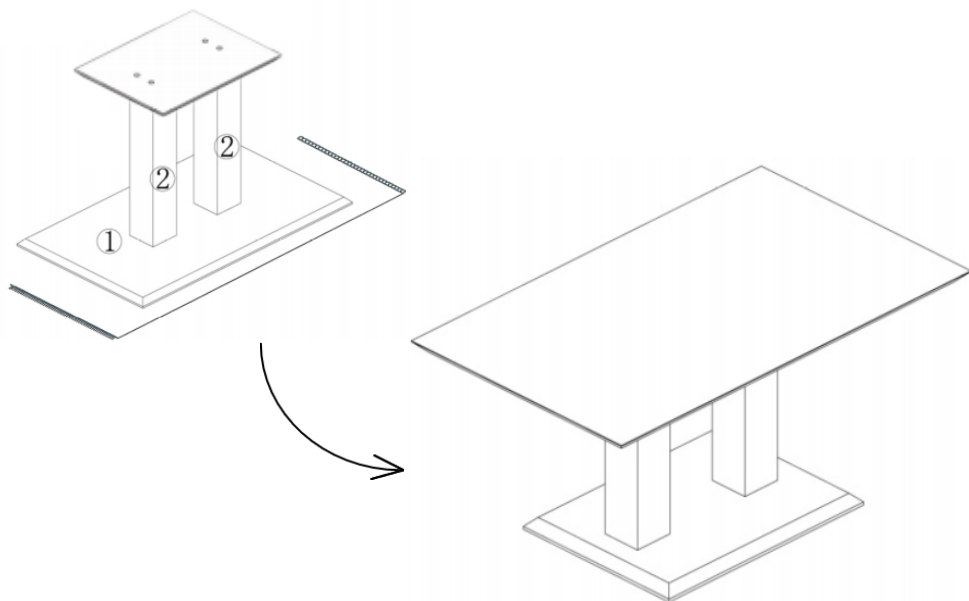

- With **help**, turn the table over to complete assembly.



Step 2

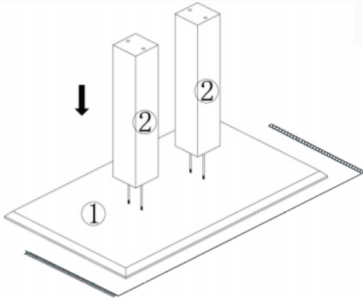

- Place the table legs (part 2) over the threaded rods as shown.

Step 3

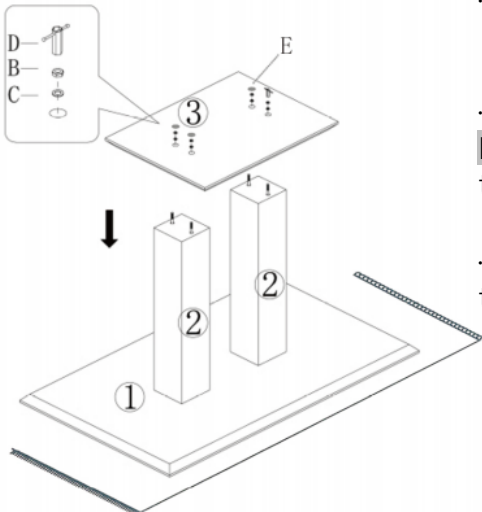

- Attach the table base (part 3) to the table legs.
- Secure using fixings C and B, with Box Spanner D to tighten.
- Once fully tightened cover the holes with Stickers E.

Step 1



· The rod end with threading stoppers inserts into the table top. Do not to screw beyond the stoppers.

· Insert threaded rods A into the assembly holes of the table top (part).

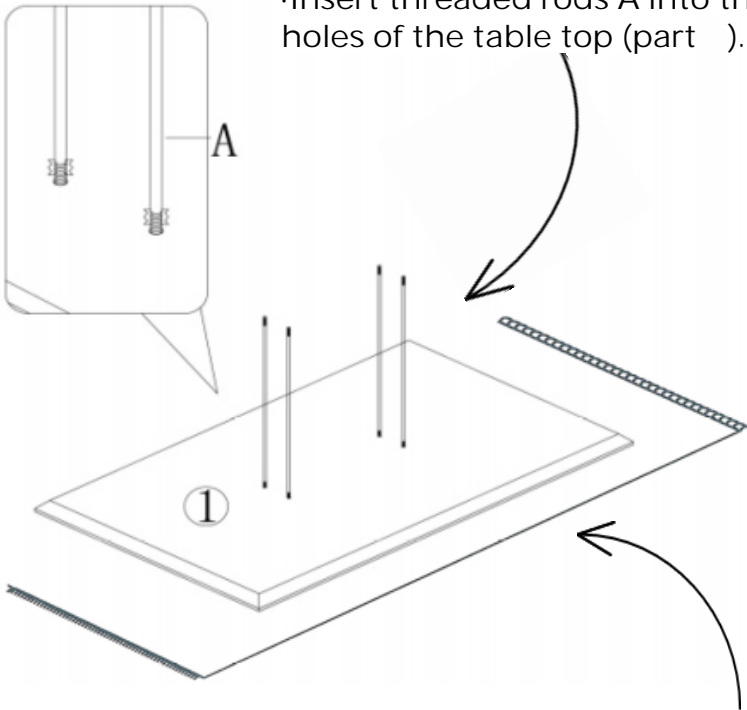

· Put the pieces on a flat soft surface e.g. a carpet to avoid scratching or bumping