

Table/Desk

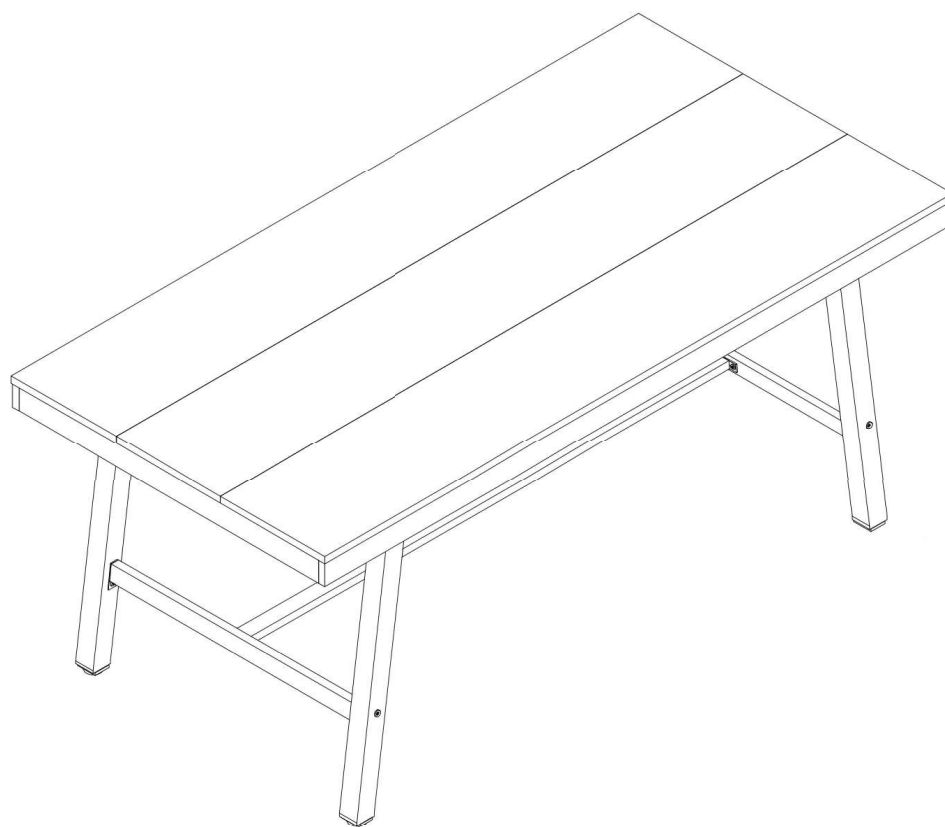

Assembly Instruction

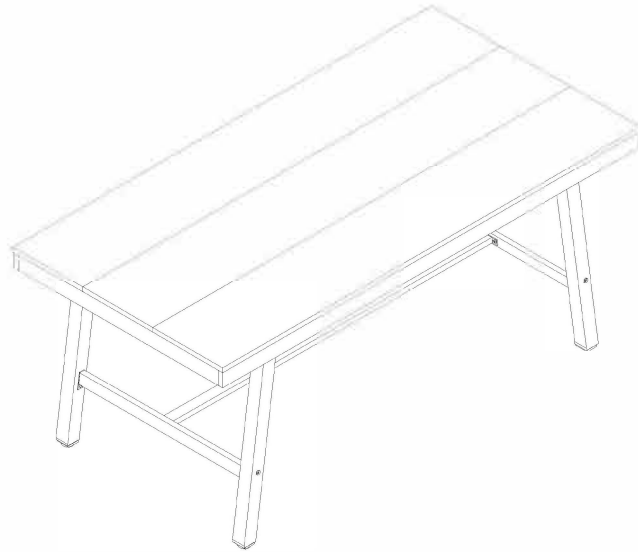

Trouble shooting:

Missing / Wrong / Broken parts and installation issues



Send email with your question pic, order NO. and screenshot of order details.



Respond within 24 hours



Issue resolved

**THIS INSTRUCTION BOOKLET CONTAINS IMPORTANT SAFETY INFORMATION.
PLEASE READ AND KEEP FOR FUTURE REFERENCE.**



- 1. Check all the components & screws are intact before assembling .**
- 2. If you notice any pieces are missing or damaged please do not assemble and contact us immediately .**
- 3. Please send an email with you order number and issues,we will respond within 24 hours.**

Two people are needed



IMPORTANT SAFETY INFORMATION

- **Please carefully read the following instructions and caution warnings before assembling the product.**
- **Following this guide will ensure that you install, use and maintain the product properly.**
- **Please keep this installation and user manual/instructions for future reference in case you need to disassemble the product.**
- **Never allow children to climb onto the product. Ensure that you have special safety measures when children are around on their own.**
- **Be sure to check that all parts of the product are intact after you open the package.**
- **Do not assemble if you notice serious damage such as cracks or bends.**
- **During installation, please use work gloves for hand safety.**
- **Please assemble the unit on carpeted floor or the flat cardboard box to avoid scratching the surface or your floor while assembling on the floor.**
- **To assemble, please use the complimentary installation tools (Phillips screwdriver).
Pay more attention to the direction of components at each step.**
- **Check the stability of the bolts, tighten them up after one or more months whenever required.**
- **It is recommended that two people work together to assemble the product.**

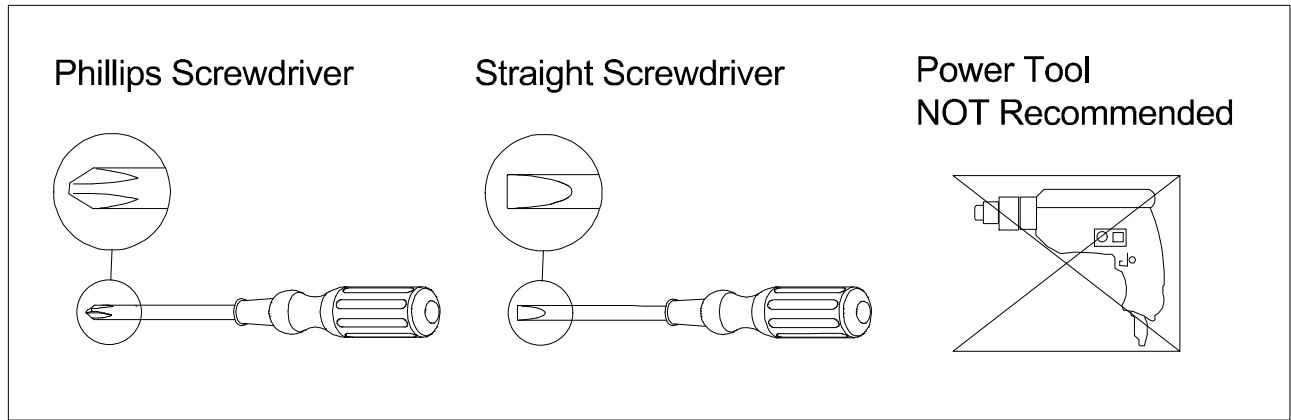

To ensure proper assembly, please read the following guides:

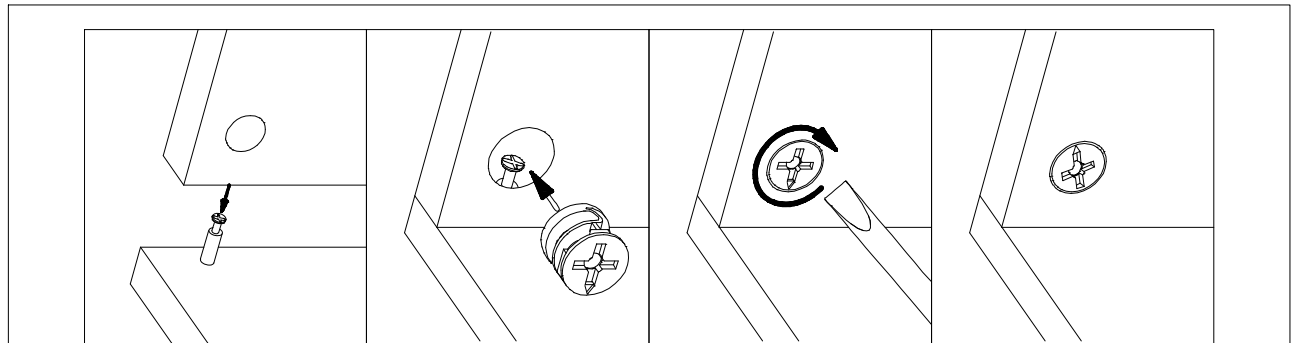
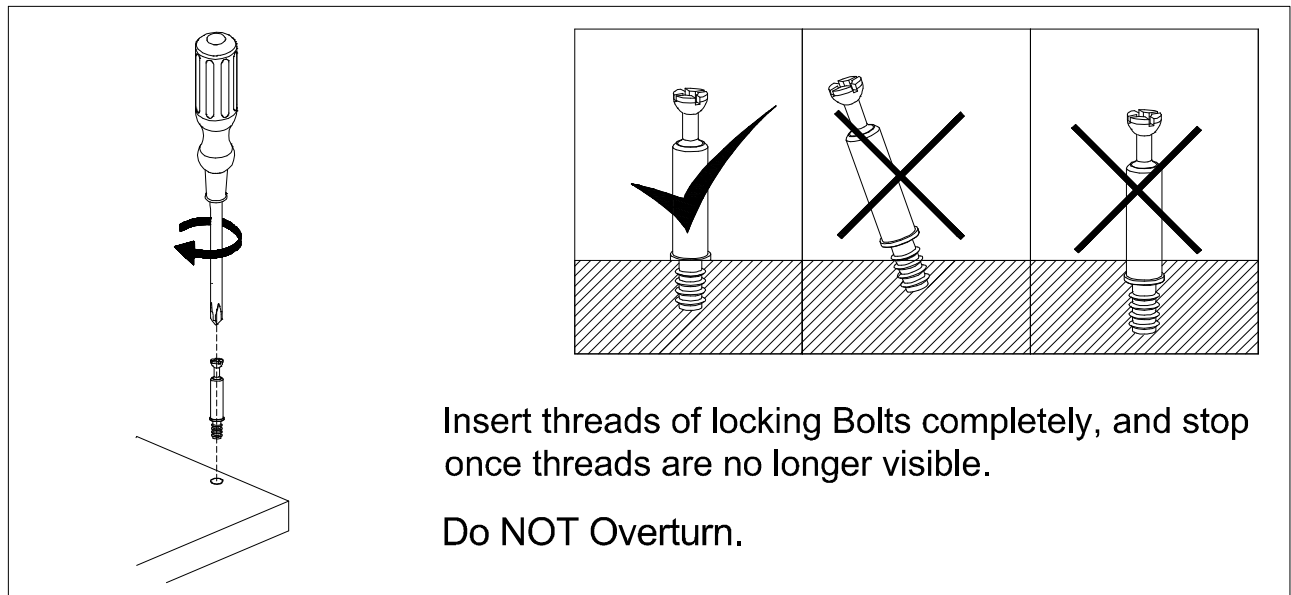

Reference this guide when assembling all Cam Locks.

Do NOT Overturn.

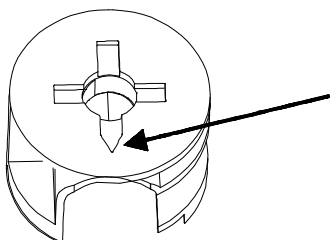







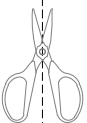
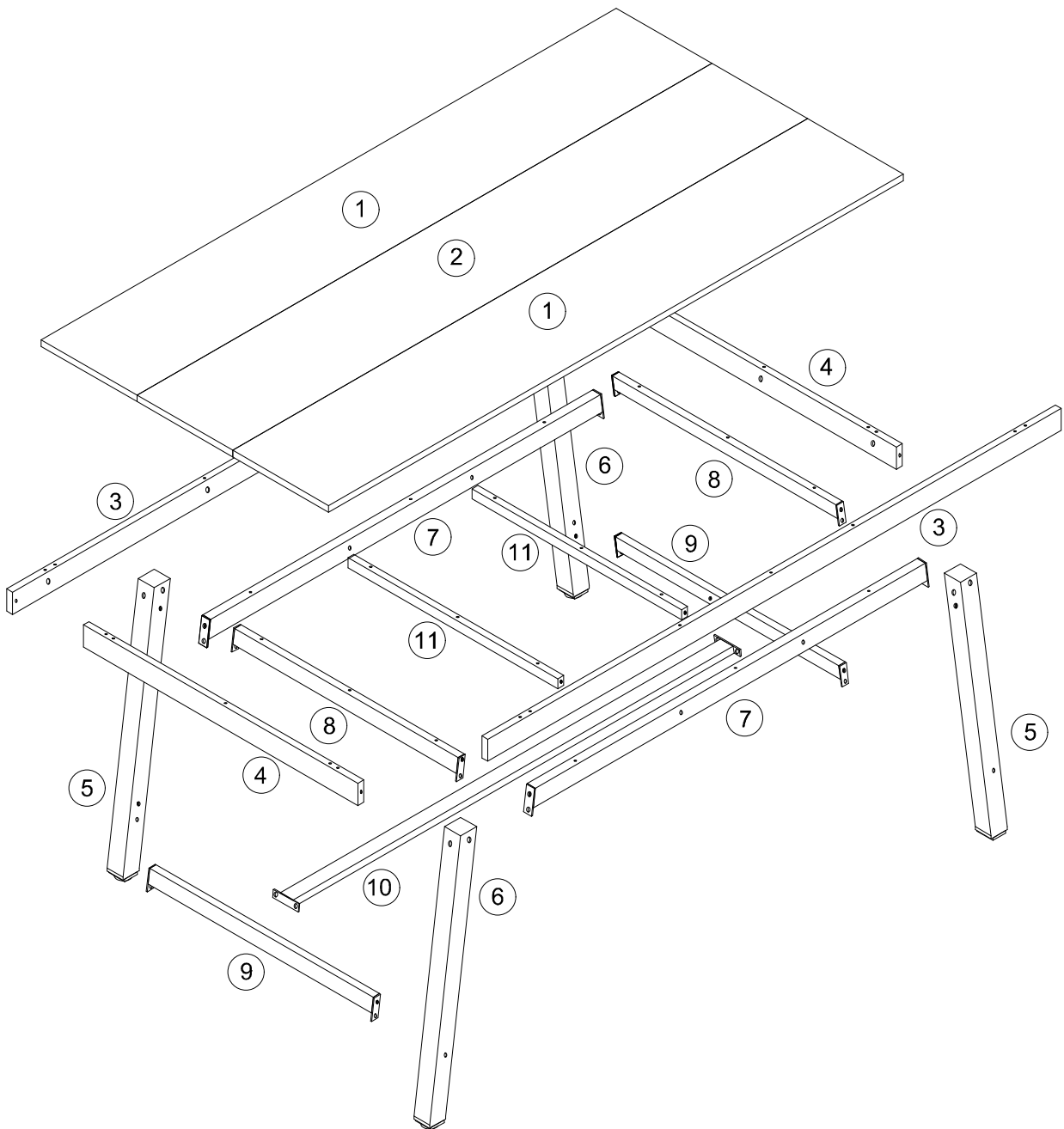



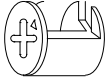
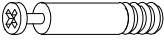
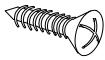

Notice:
"Pointer Arrow" on cam face the Bolt
when inserting the cam.

COMPONENTS ID Nr.

| Part Nr. | Qty | Part Nr. | Qty | Part Nr. | Qty |
|----------|------|----------|------|----------|------|
| 1 | 2pcs | 2 | 1pc | 3 | 2pcs |
| 4 | 2pcs | 5 | 2pcs | 6 | 2pcs |
| 7 | 2pcs | 8 | 2pcs | 9 | 2pcs |
| 10 | 1pc | 11 | 2pcs | | |



Please cut if you need, but keep for the future use after assembling

| | | | |
|---|---|--|---|
| <p>A x 22+2</p>  <p>Ø15x10mm</p> | <p>B x 14+1</p>  <p>Ø6x34mm</p> | <p>C x 40+2</p>  <p>3.5x14mm</p> | <p>D x 20+2</p>  <p>Ø8x30mm</p> |
| <p>E x 4</p>  | <p>F x 12+1</p>  <p>5/16"x63mm</p> | <p>G x 12+1</p>  <p>1/4 "x60mm</p> | <p>H x 16+1</p>  <p>1/4 "x12mm</p> |
| <p>I x 10+1</p>  <p>1/4 "x40mm</p> | <p>J x 1</p>  <p>5mm</p> | <p>K x 1</p>  <p>4mm</p> | <p>L x 6</p>  |
| <p>M x 8</p>  <p>Ø10x10mm</p> | <p>N x 8</p>  <p>Ø6x40mm</p> | | |

PRODUCT ASSEMBLY

1

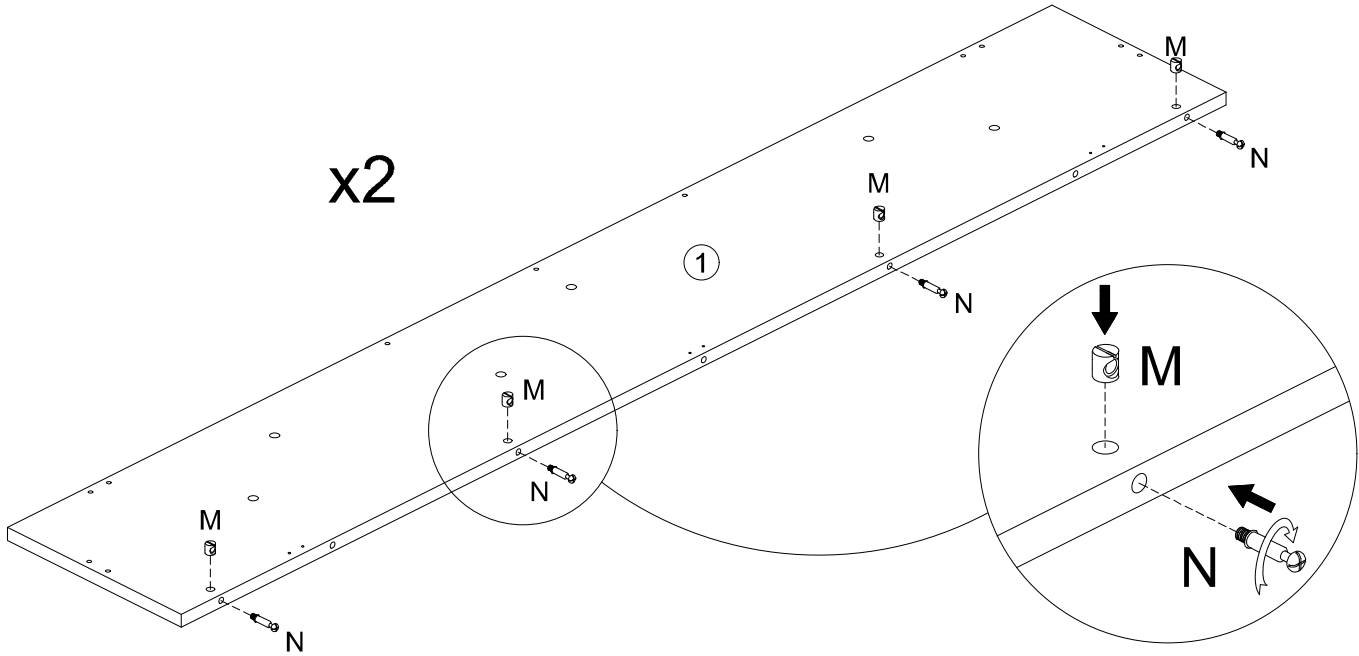
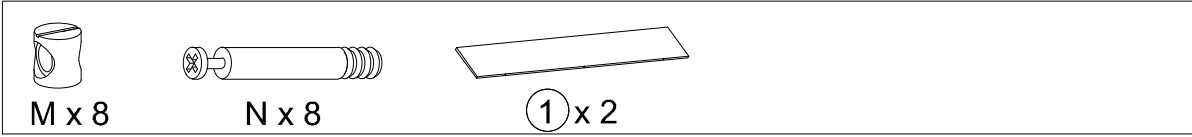

2

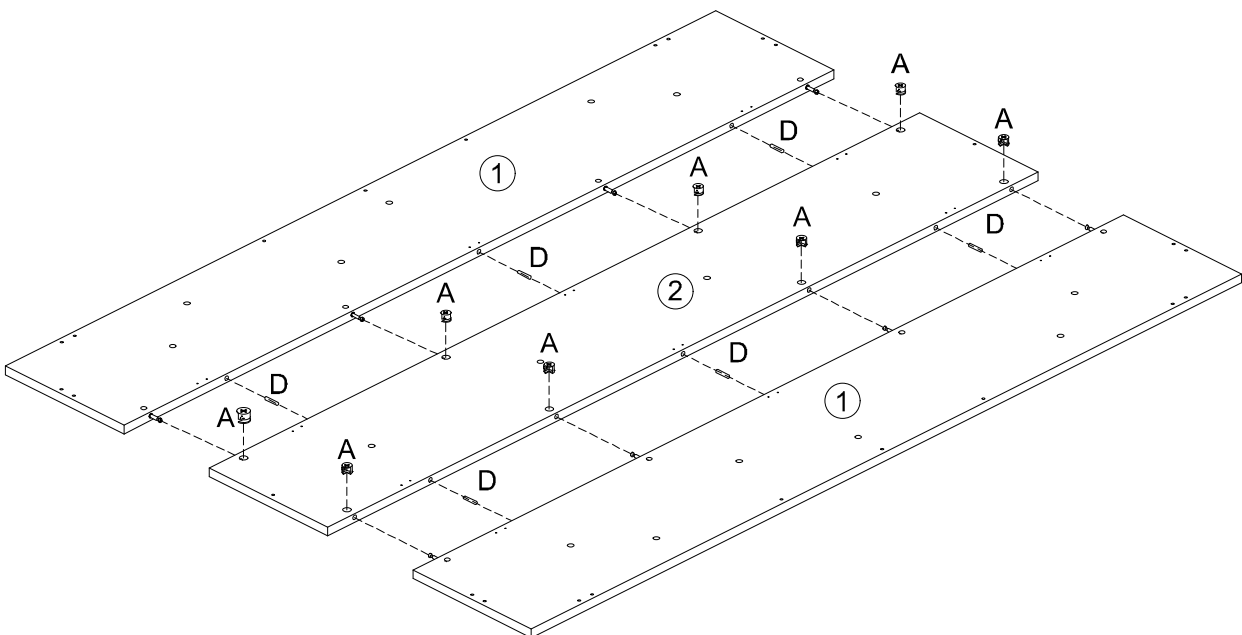
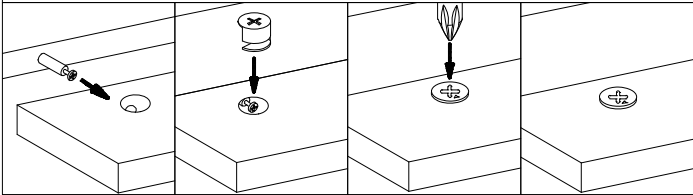
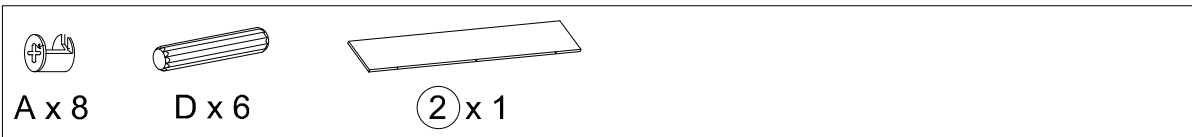

PRODUCT ASSEMBLY

3

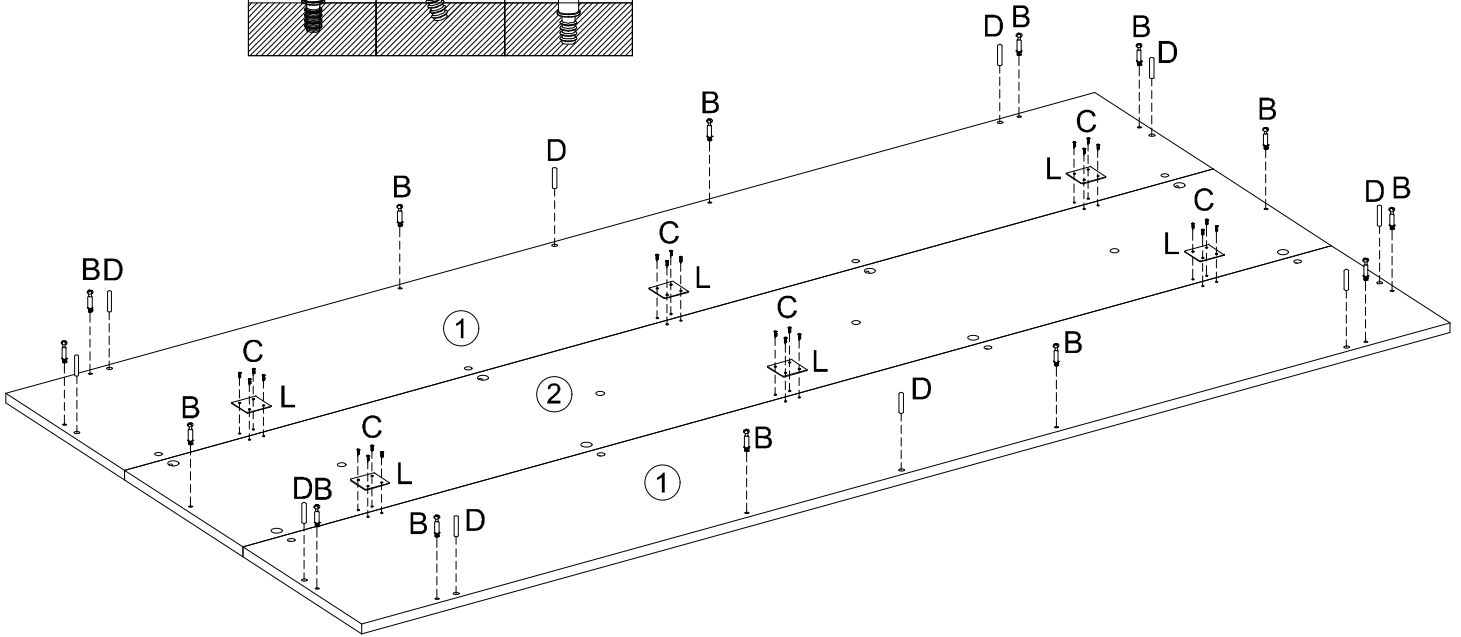
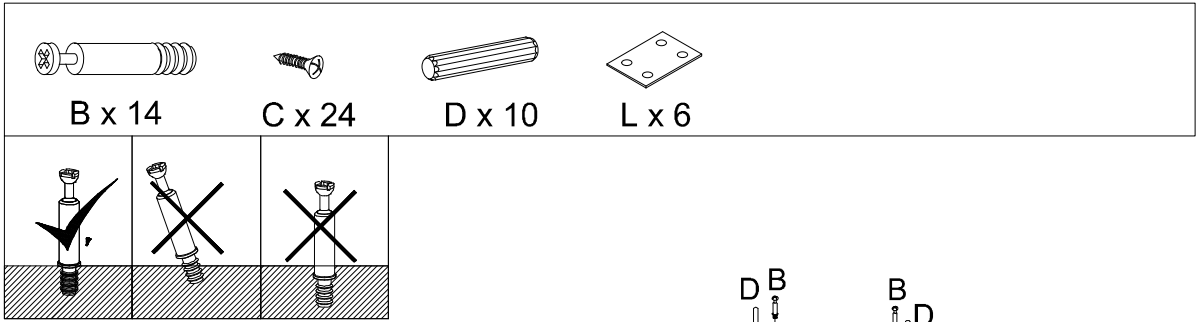

4

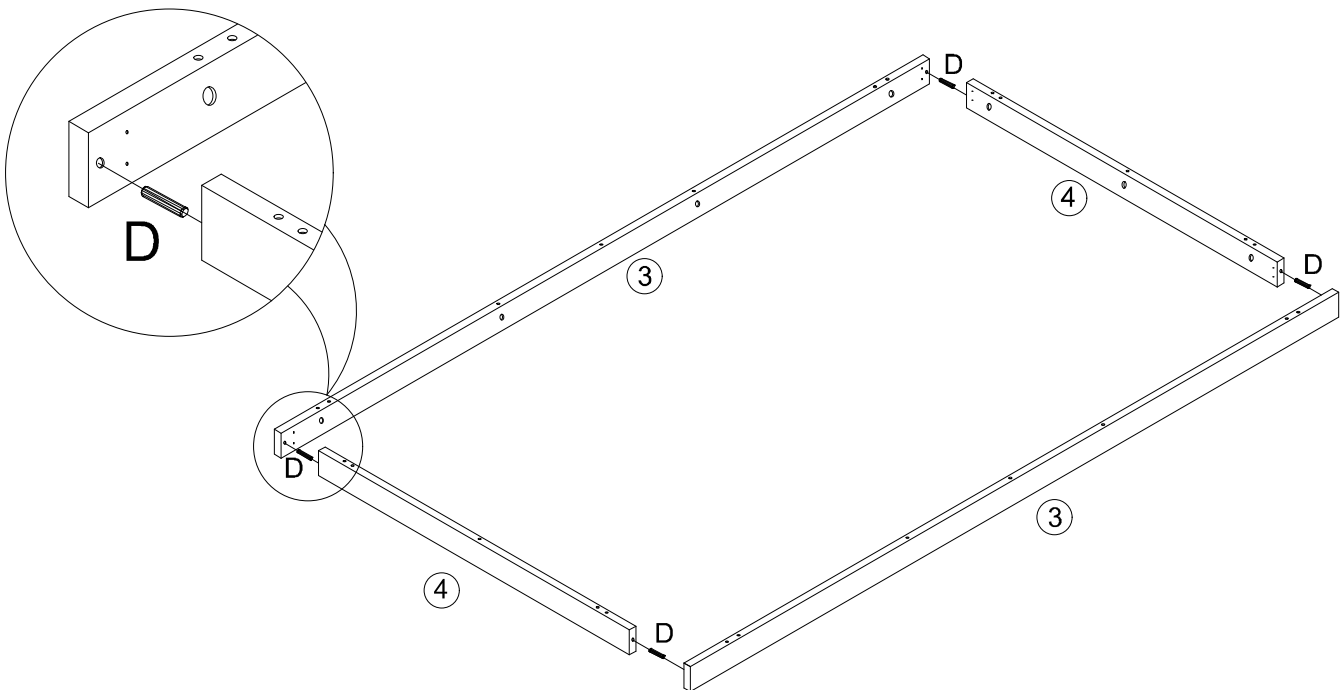
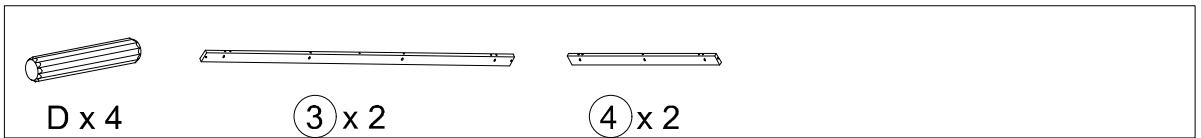

PRODUCT ASSEMBLY

5

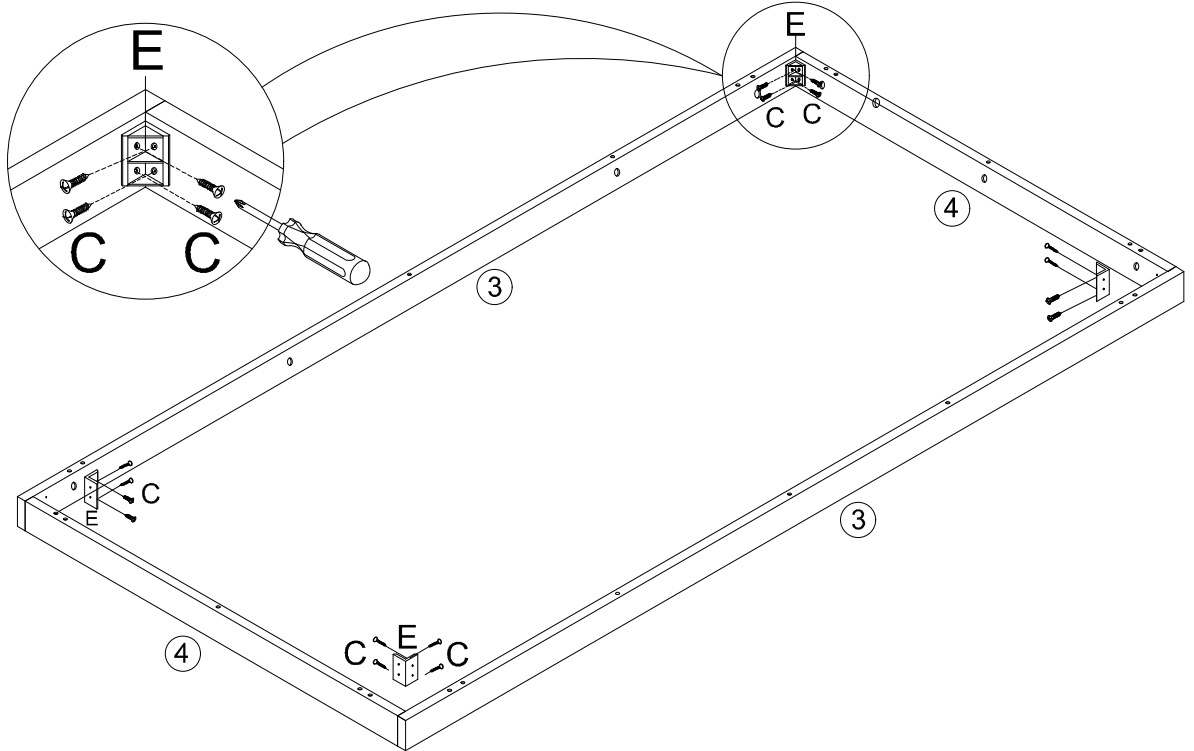

6

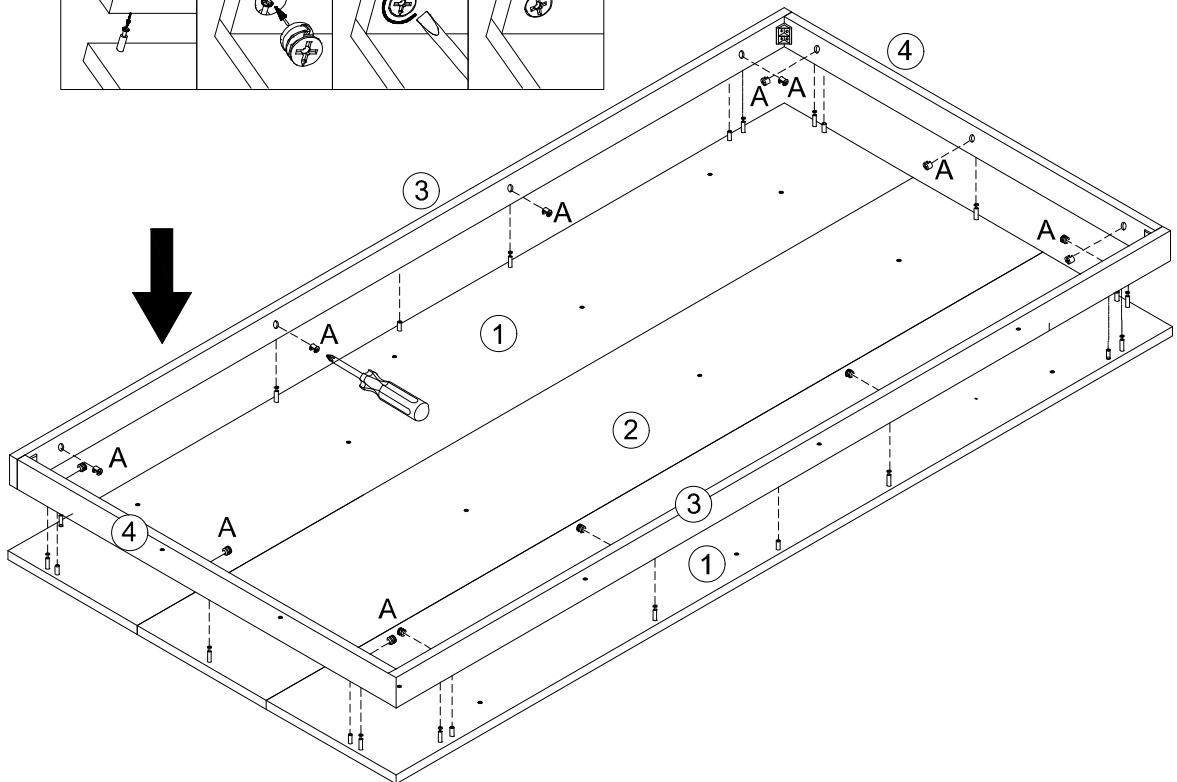
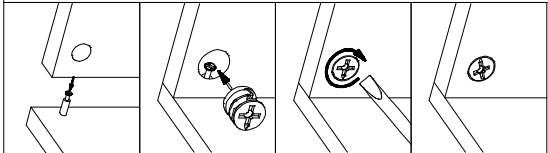

PRODUCT ASSEMBLY

7

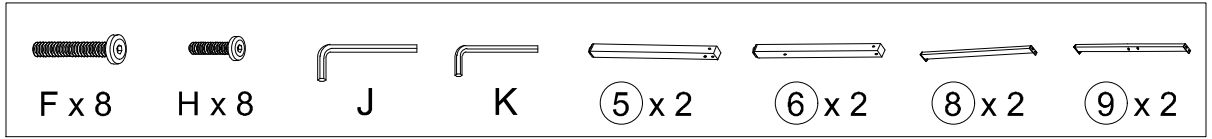

MAKE SURE THREADING AT THE SAME SIDE

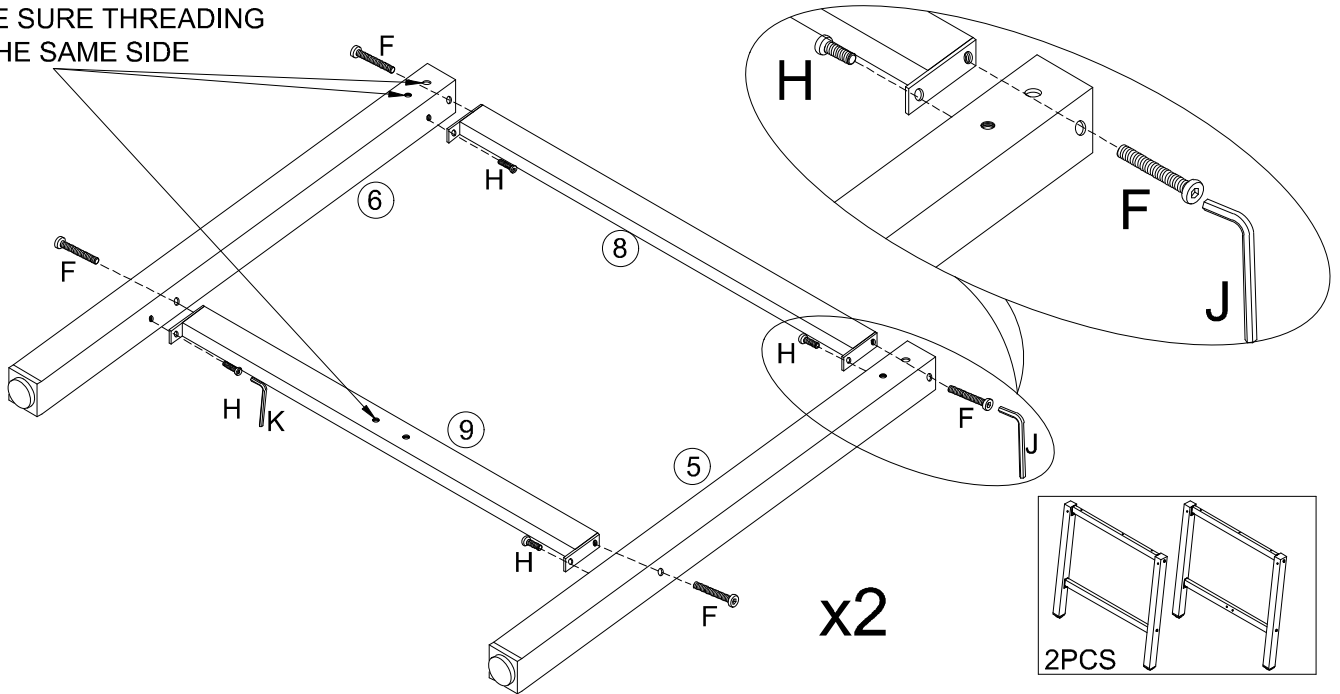

DO NOT FULLY TIGHTEN ALLEN SCREWS UNTIL THE END OF STEP 10

8

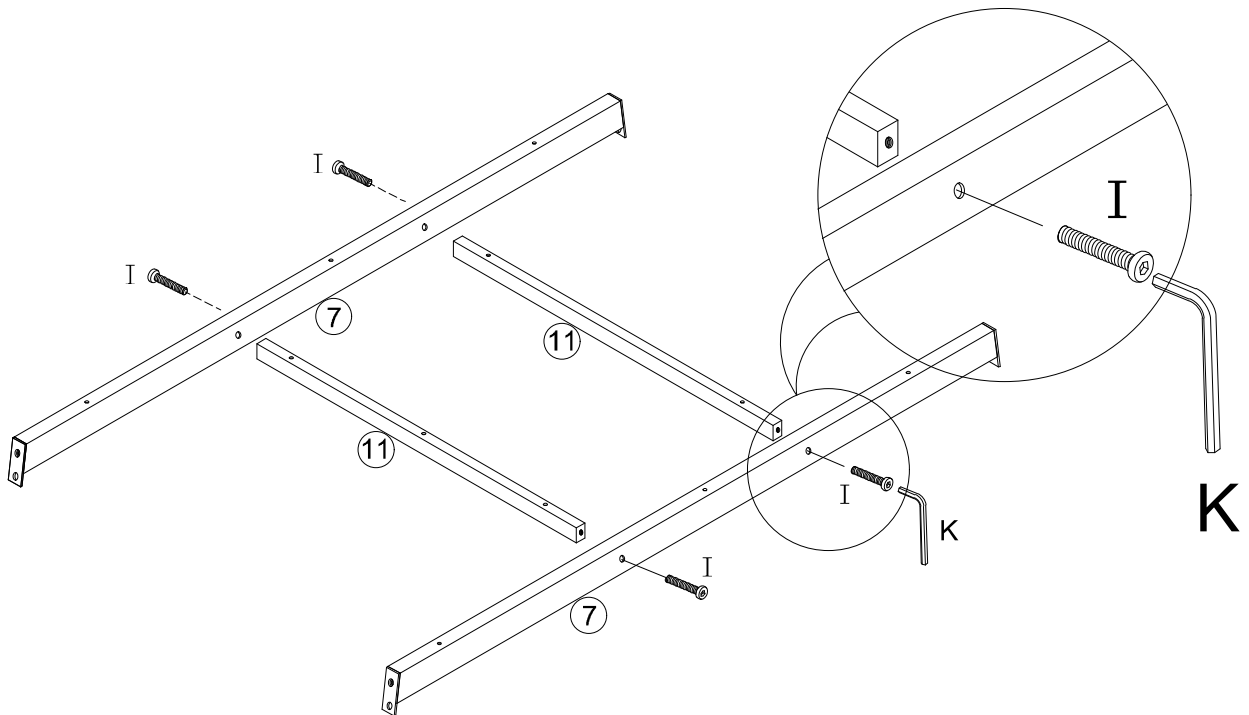
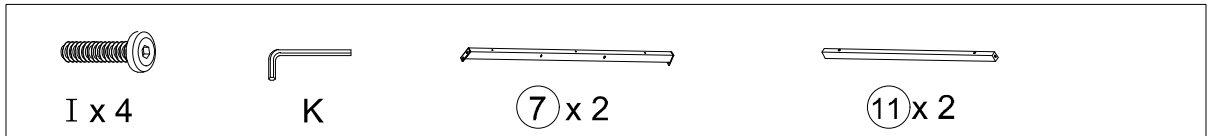

DO NOT FULLY TIGHTEN ALLEN SCREWS UNTIL THE END OF STEP 10

PRODUCT ASSEMBLY

9

- F x 4
- H x 8
- J
- K
- 10 x 1

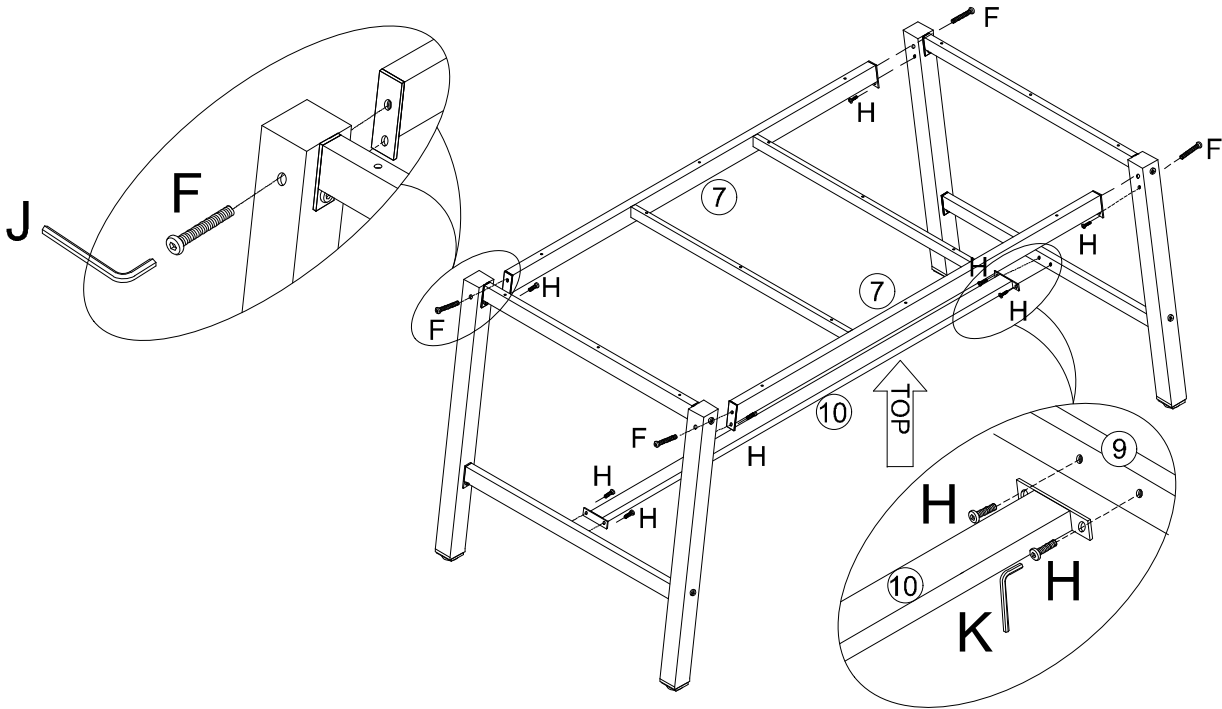

DO NOT FULLY TIGHTEN ALLEN SCREWS UNTIL THE END OF STEP 10

10

- I x 6
- G x 12
- J
- K

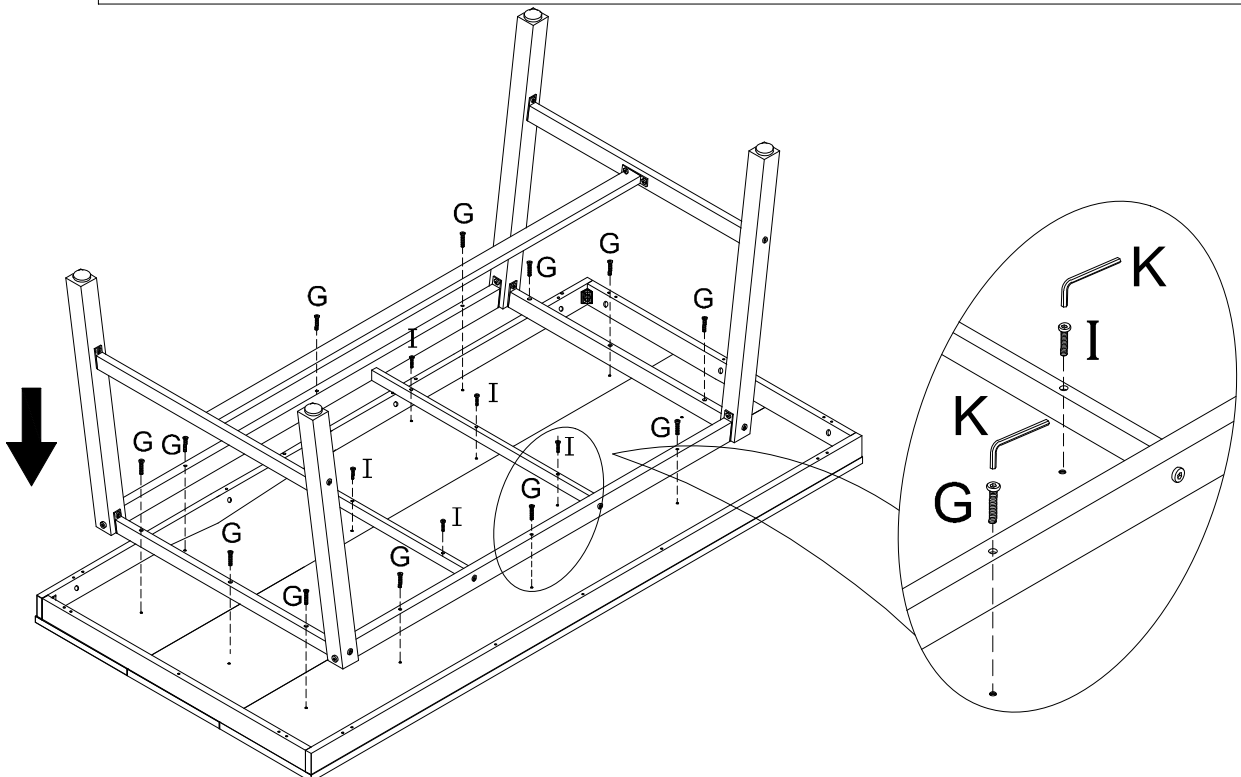

FULLY TIGHTEN ALL SCREWS AT THE END OF THIS STEP