

# ASSEMBLY INSTRUCTIONS

## Full Storage Bed

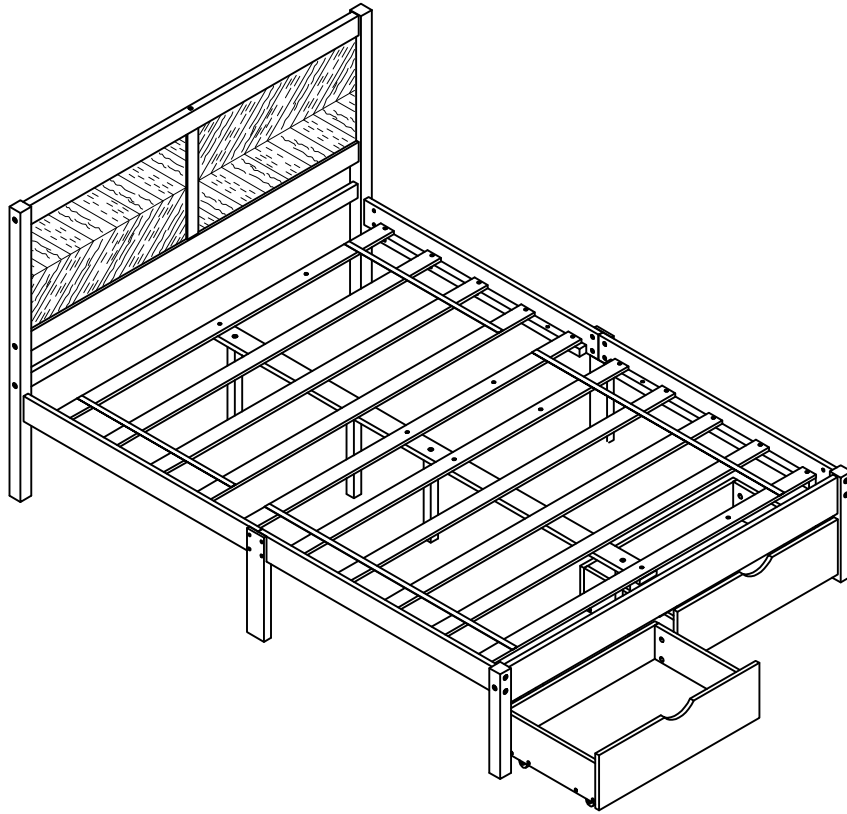







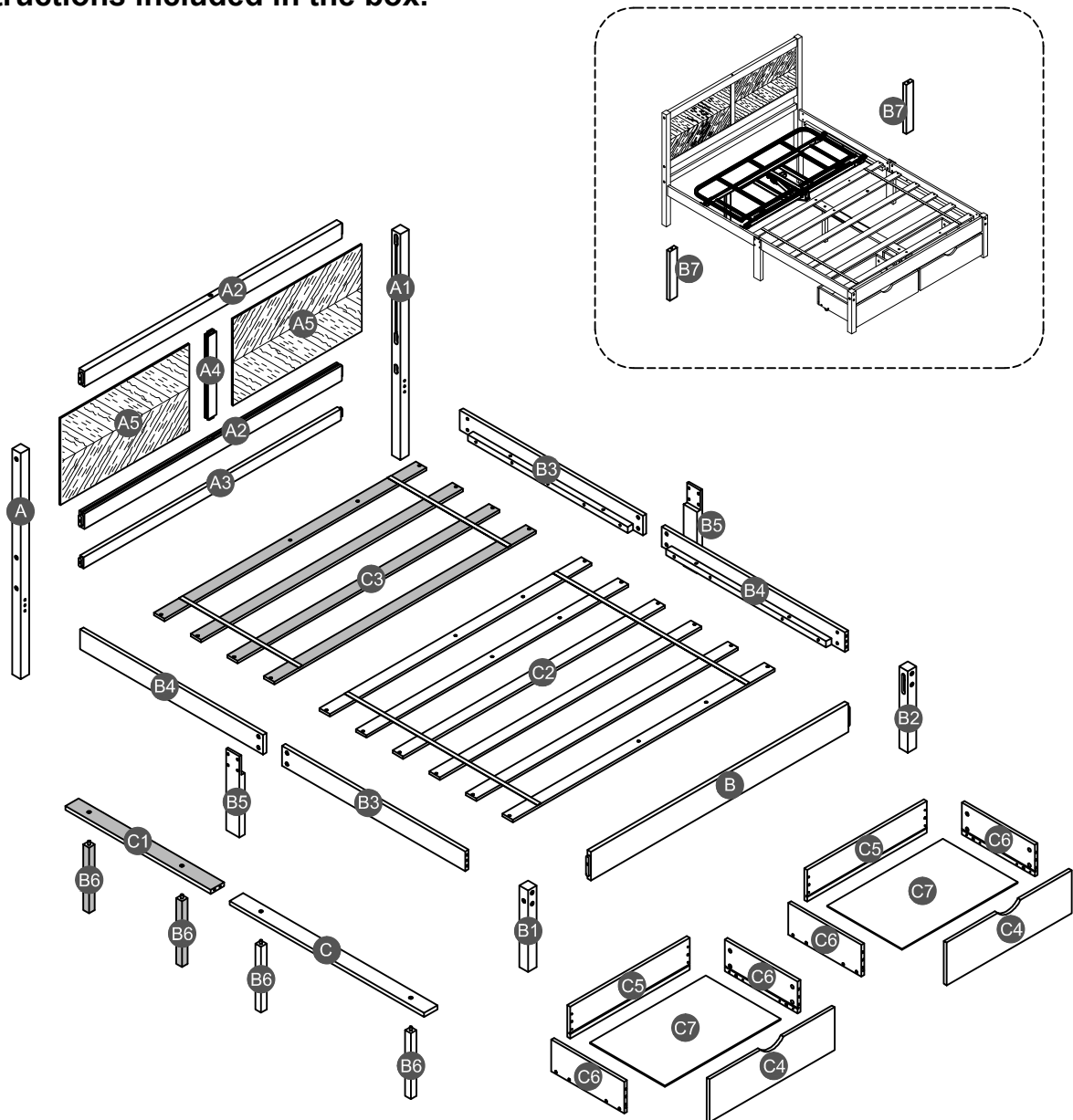



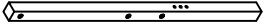
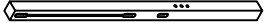

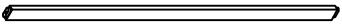

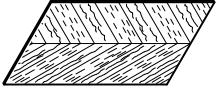
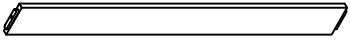
## Detail View

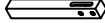
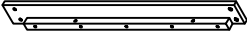
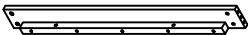
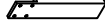
If you need to assemble the electric bed, you do NOT need to install the part of C3 / C1 / B6 (marked with deep color as the picture below). Instead, please assemble B7 if you have purchased the electric bed. (Please refer to the last page of instructions).

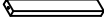

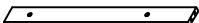
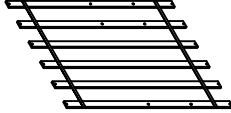
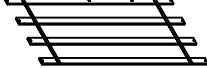
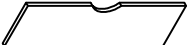

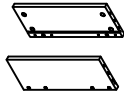



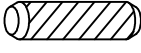
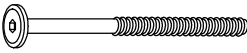
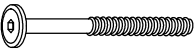

To assemble the electric bed, please refer to the additional installation instructions included in the box.

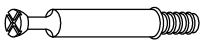

# Part List

<p><b>A</b></p>  <p>Leg HB (left) - 1pc</p>	<p><b>A1</b></p>  <p>Leg HB (right) - 1pc</p>	<p><b>A2</b></p>  <p>Upper horizontal bar HB - 2pcs</p>
<p><b>A3</b></p>  <p>Lower horizontal bar HB - 1pc</p>	<p><b>A4</b></p>  <p>Vertical bar HB - 1pc</p>	<p><b>A5</b></p>  <p>Panel HB - 2pcs</p>
<p><b>B</b></p>  <p>Horizontal bar FB - 1pc</p>	<p><b>B1</b></p>  <p>Leg FB (left) - 1pc</p>	<p><b>B2</b></p>  <p>Leg FB (right) - 1pc</p>
<p><b>B3</b></p>  <p>Side rail (left front/right back) - 2pcs</p>	<p><b>B4</b></p>  <p>Side rail (left back/right front) - 2pcs</p>	<p><b>B5</b></p>  <p>Leg support side rail - 2pcs</p>
<p><b>B6</b></p>  <p>Leg support - 4pcs</p>	<p><b>B7</b></p>  <p>Leg support - 2pcs</p>	<p><b>C</b></p>  <p>Lower support slat - 1pc</p>
<p><b>C1</b></p>  <p>Lower support slat - 1pc</p>	<p><b>C2</b></p>  <p>Slats - 1set</p>	<p><b>C3</b></p>  <p>Slats - 1set</p>
<p><b>C4</b></p>  <p>Front drawer panel - 2pcs</p>	<p><b>C5</b></p>  <p>Back drawer panel - 2pcs</p>	<p><b>C6</b></p>  <p>Left / right drawer panel - 4pcs</p>
<p><b>C7</b></p>  <p>Drawer bottom - 2pcs</p>		

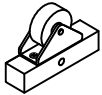
# Hardware List

<b>1</b>  Ø10*20mm Wood dowel (8pcs)	<b>2</b>  Ø8*30mm Wood dowel (14pcs)	<b>3</b>  (Ø15)1/4"*100mm Hex-Head bolts (2pcs)
<b>4</b>  (Ø15)1/4"*80mm Hex-Head bolts (18pcs)	<b>5</b>  (Ø12)1/4"*35mm Hex-Head bolts (8pcs)	<b>6</b>  (1/4")4.5*58mm Allen key (1pc)
<b>7</b>  1/4"*15 (9.5mm) Horizontal-Hole bolts(20pcs)	<b>8</b>  Ø4*30mm Wood screws (46pcs)	<b>9</b>  Ø3.5*19mm Wood screws (4pcs)
<b>10</b>  Ø7"*35mm Cam lock (16pcs)	<b>11</b>  Ø14*9mm Cam lock (16pcs)	<b>12</b>  100*52*20 mm Wheels (8pcs)
<b>13</b>  70*50*19 mm Drawer stopper (3pcs)	<b>14</b>  75*20*2 mm Metal bracket (1pc)	

## ASSEMBLY TOOLS REQUIRED ( NOT INCLUDED )

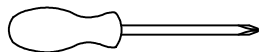

( Phillip head screwdriver )



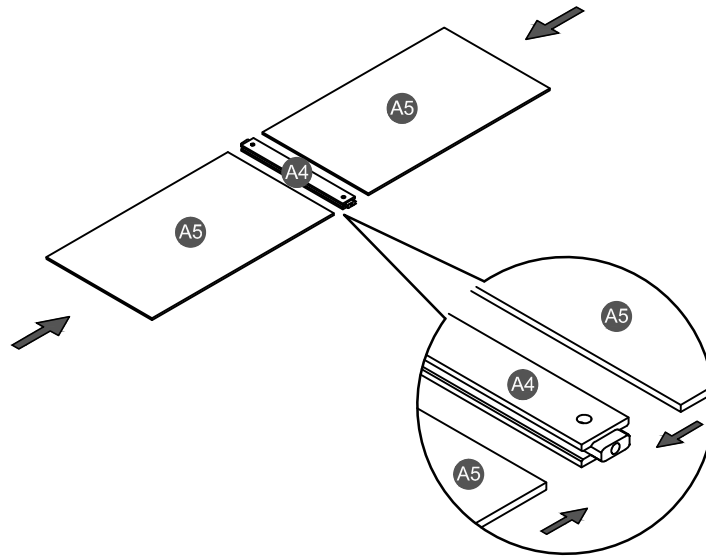

PLEASE BE CAREFUL DO NOT DAMAGE THE HOLE POSITION WHEN YOU USE POWER TOOLS !

**STEP 1:**

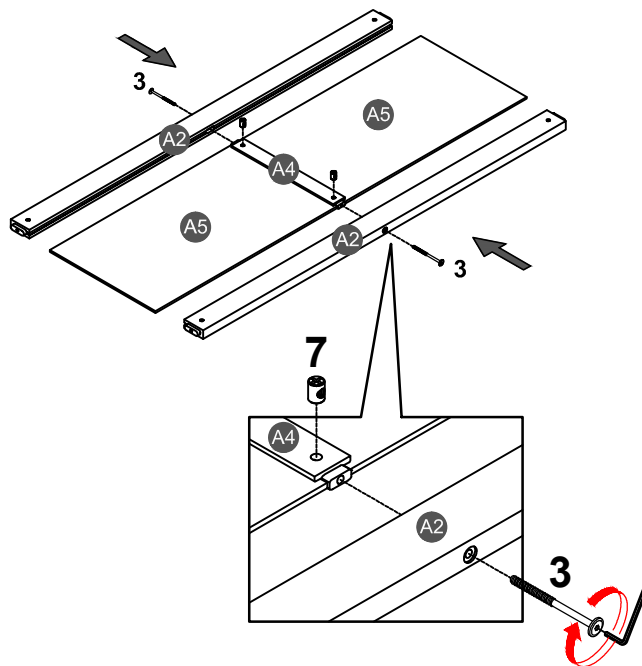

**STEP 2:**



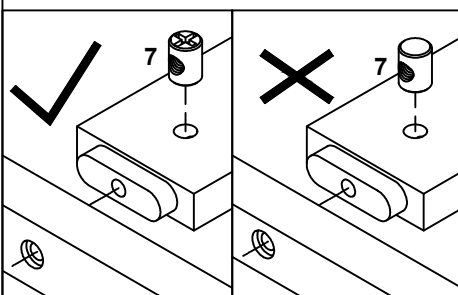

<b>3</b>		<b>7</b>	
<b>2PCS</b>		<b>2PCS</b>	



Note: Part 7 will face up with the "x" mark on it, otherwise it cannot be tightened

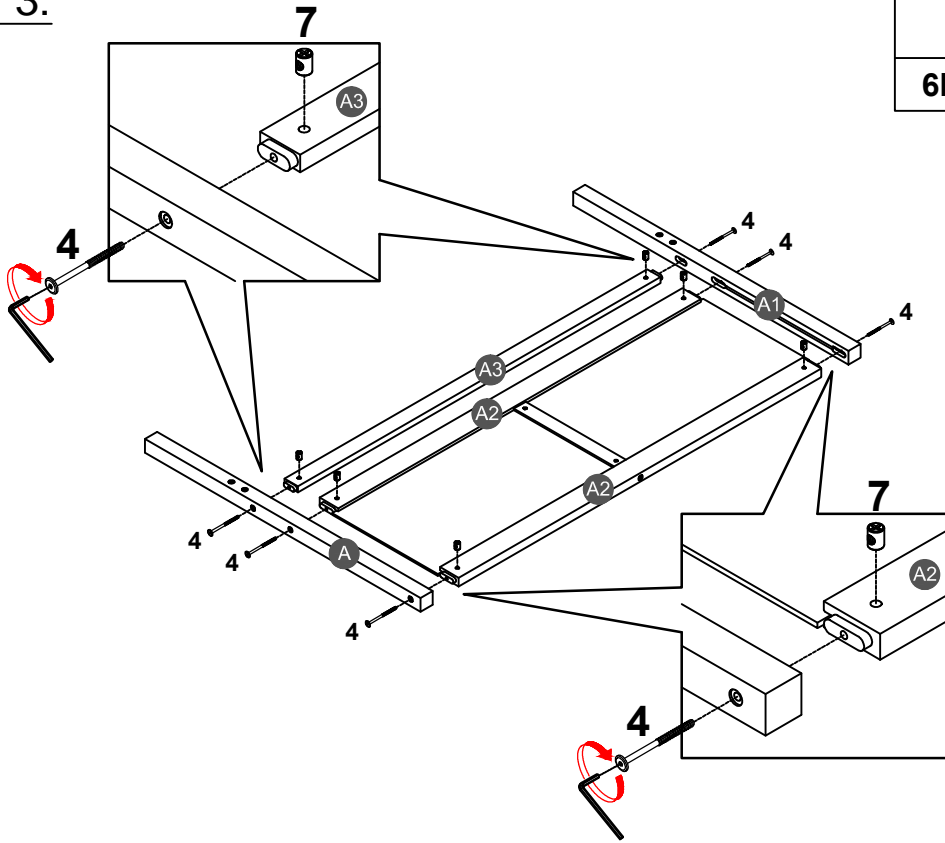

**STEP 3:**



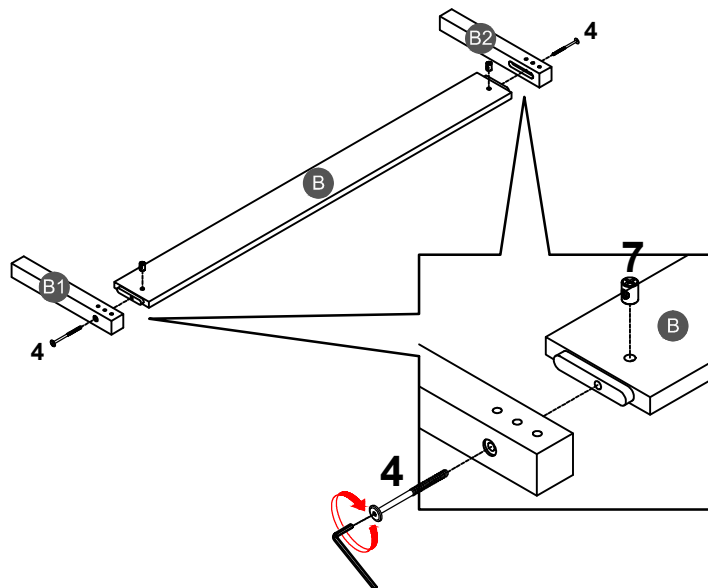

4		7	
6PCS		6PCS	

**STEP 4:**



4		7	
2PCS		2PCS	

**STEP 5:**

<b>8</b>		<b>13</b>	
<b>6PCS</b>		<b>3PCS</b>	

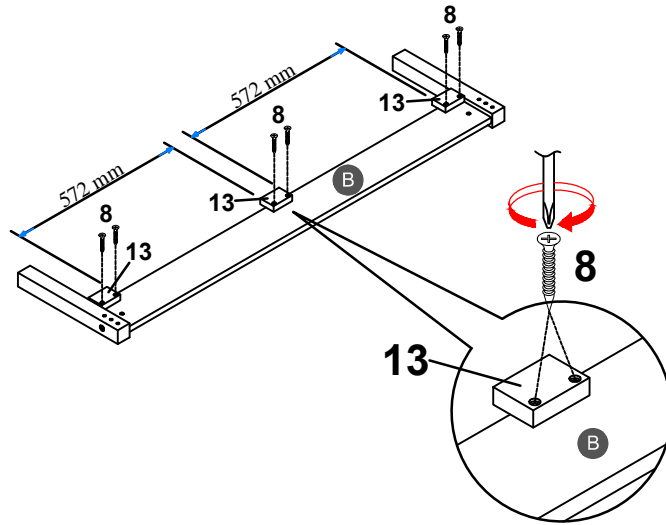

**STEP 6:**

<b>5</b>	
<b>8PCS</b>	

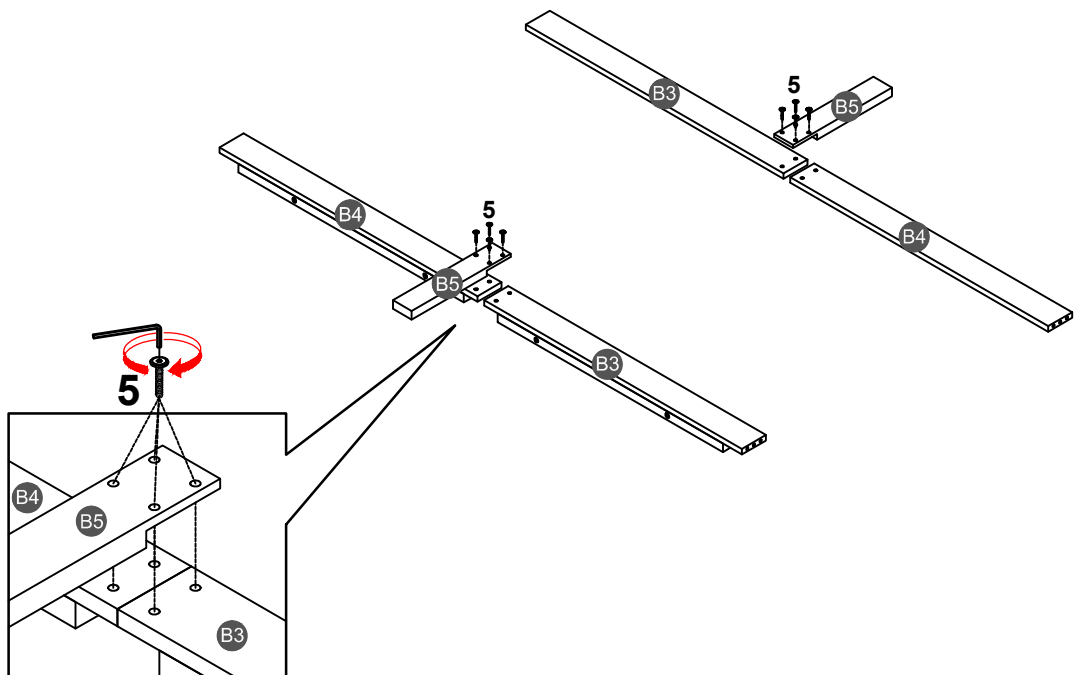

**STEP 7:**

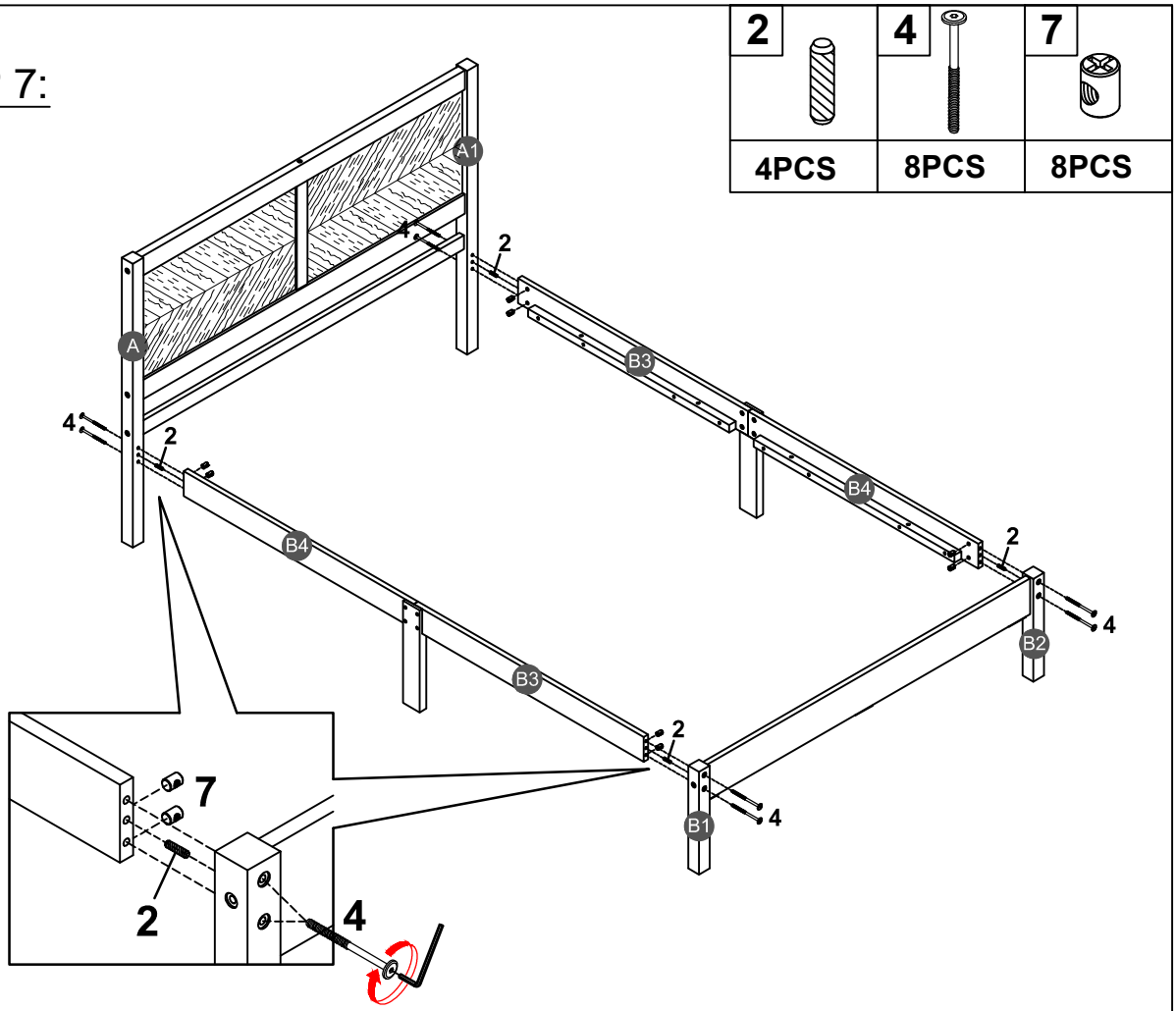

<b>2</b>		<b>4</b>		<b>7</b>	
<b>4PCS</b>		<b>8PCS</b>		<b>8PCS</b>	

**STEP 8:**

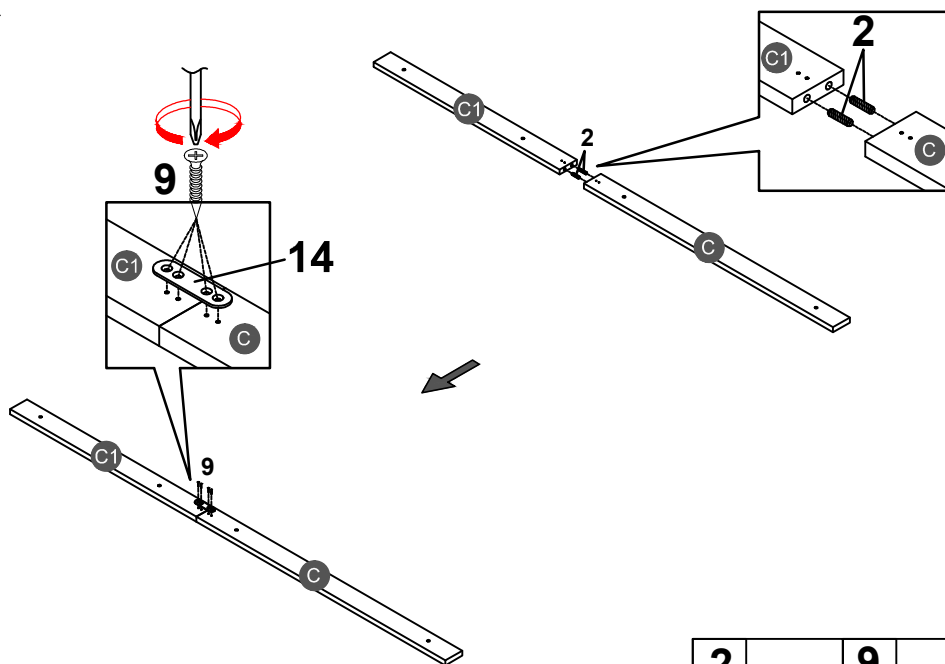

<b>2</b>		<b>9</b>		<b>14</b>	
<b>2PCS</b>		<b>4PCS</b>		<b>1PC</b>	

**STEP 9:**

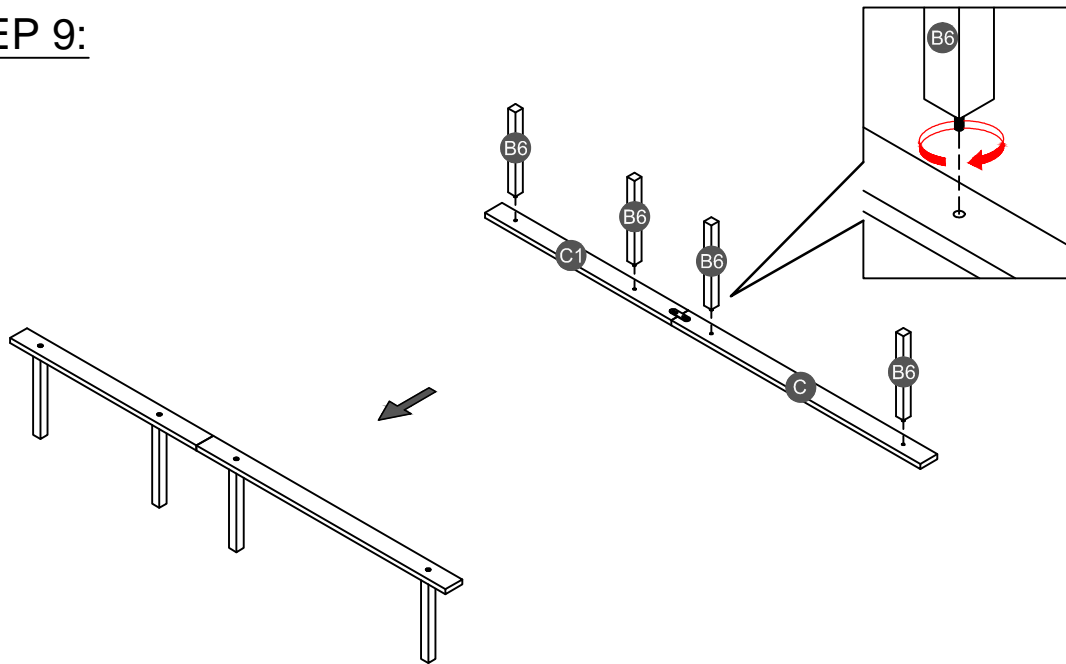

Assembling leg support (B6) with lower support slat (C & C1)  
later rotate, Move support slat inside Full bed.

**STEP 10:**

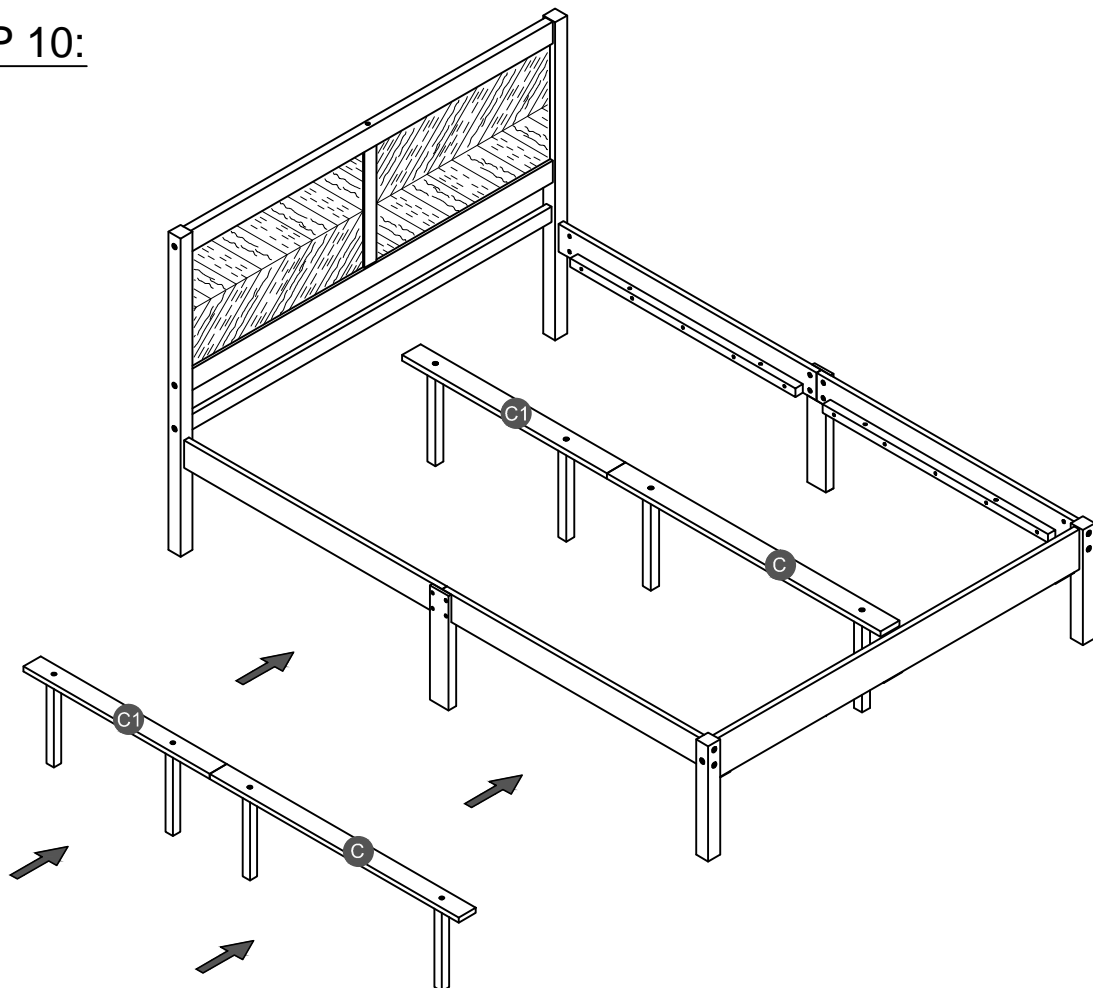

### STEP 11:

8



24PCS

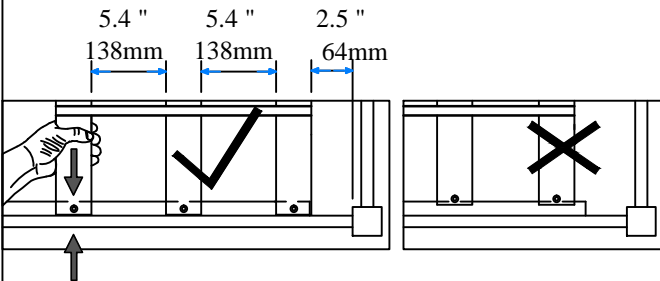
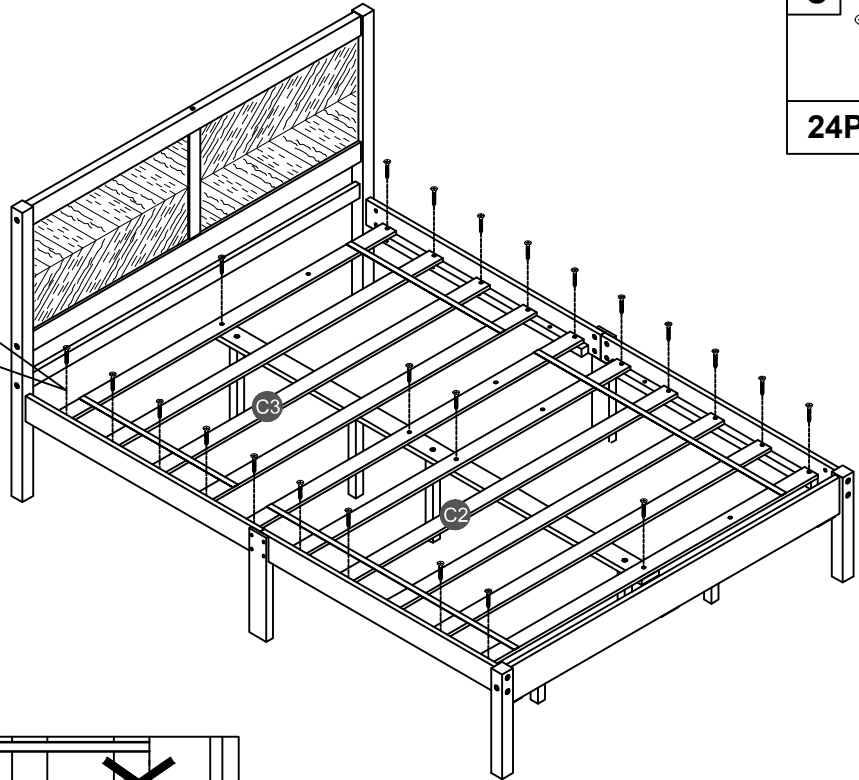
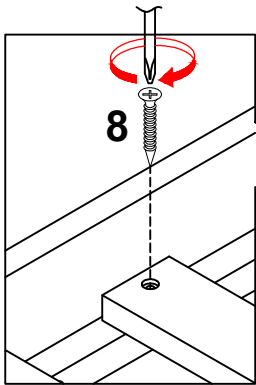

**NOTE:** Please make sure the bed slats close to the side rail before locking the screws to avoid breakage. This step is required for both the left and right sides. Moreover, please do not lock the screws of the bed slats at the outermost edge to avoid damaging.

### STEP 12:

10

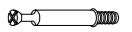

16PCS

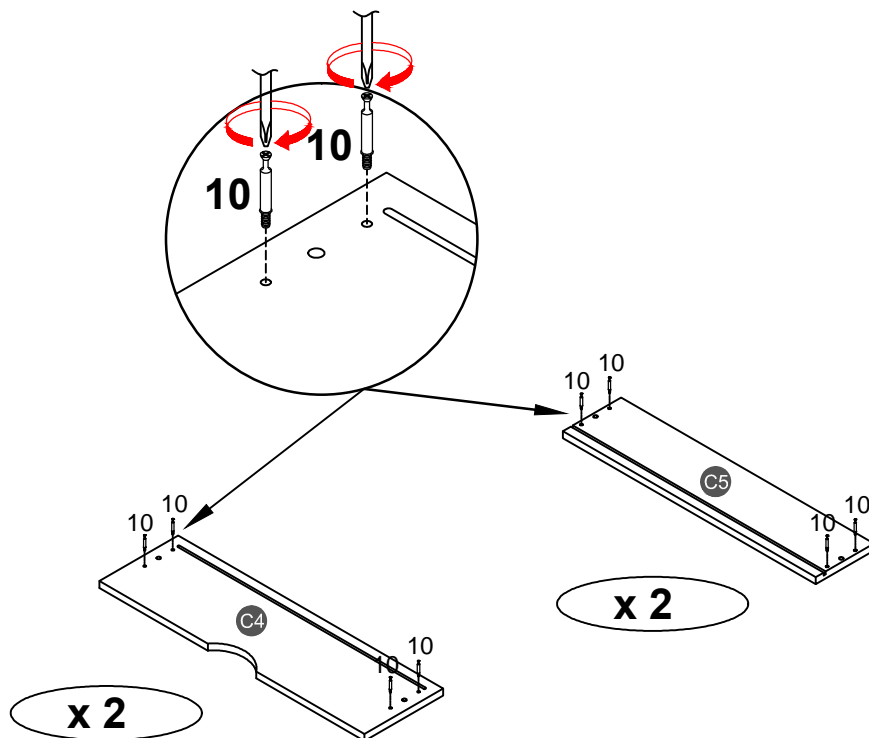

**STEP 13:**

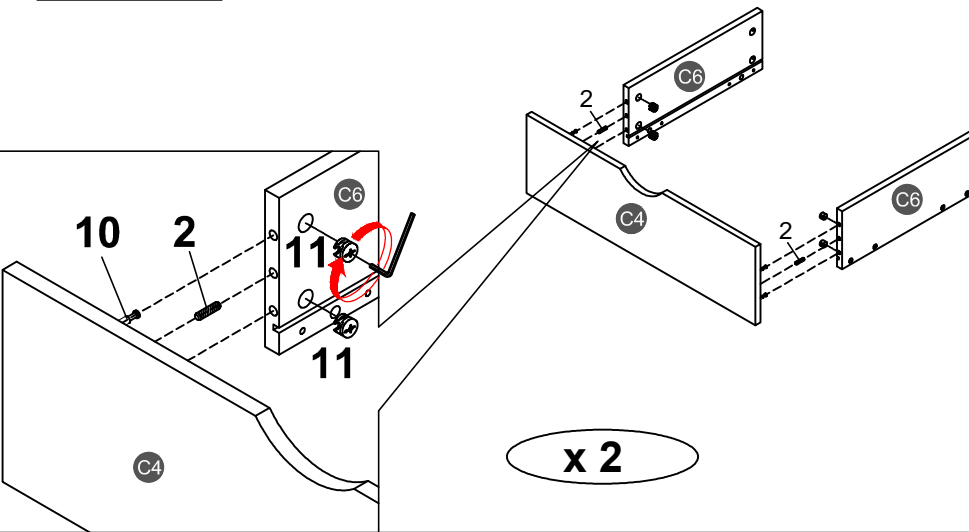

2	
4PCS	
11	
8PCS	

**STEP 14:**

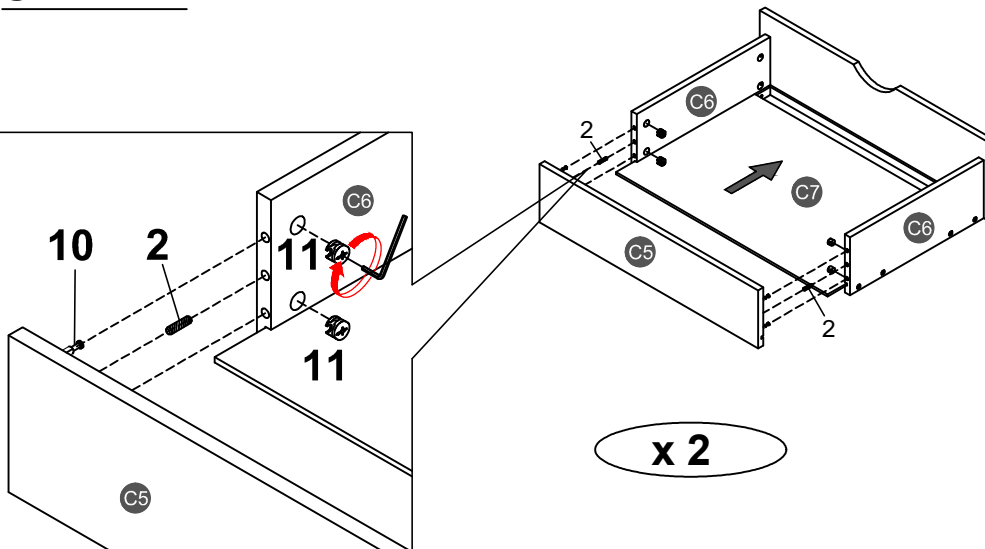

2	
4PCS	
11	
8PCS	

**STEP 15:**

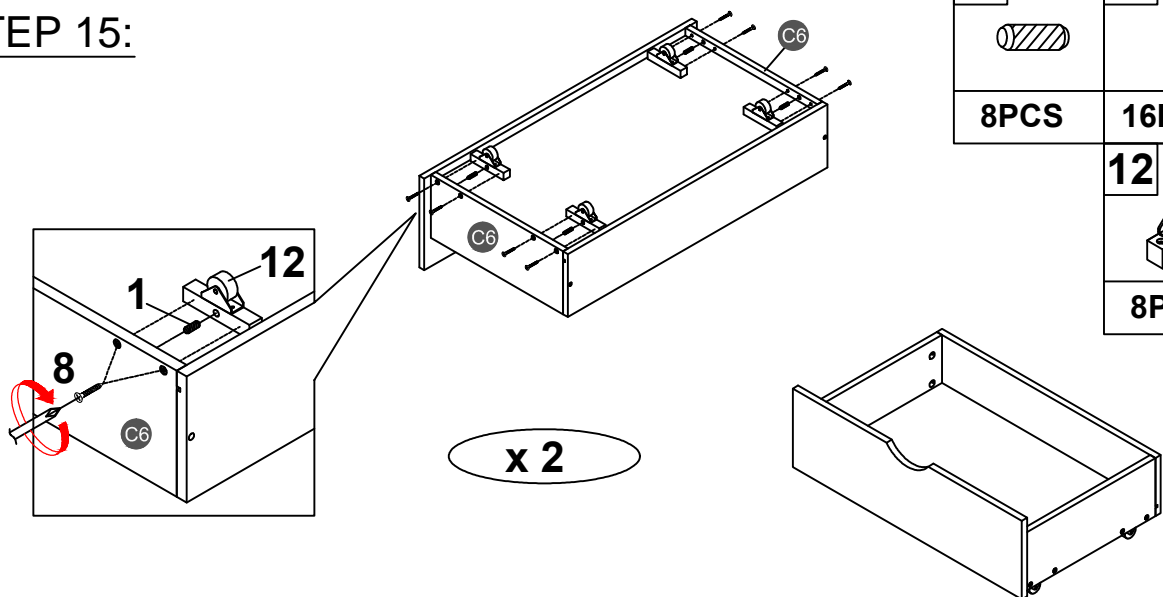

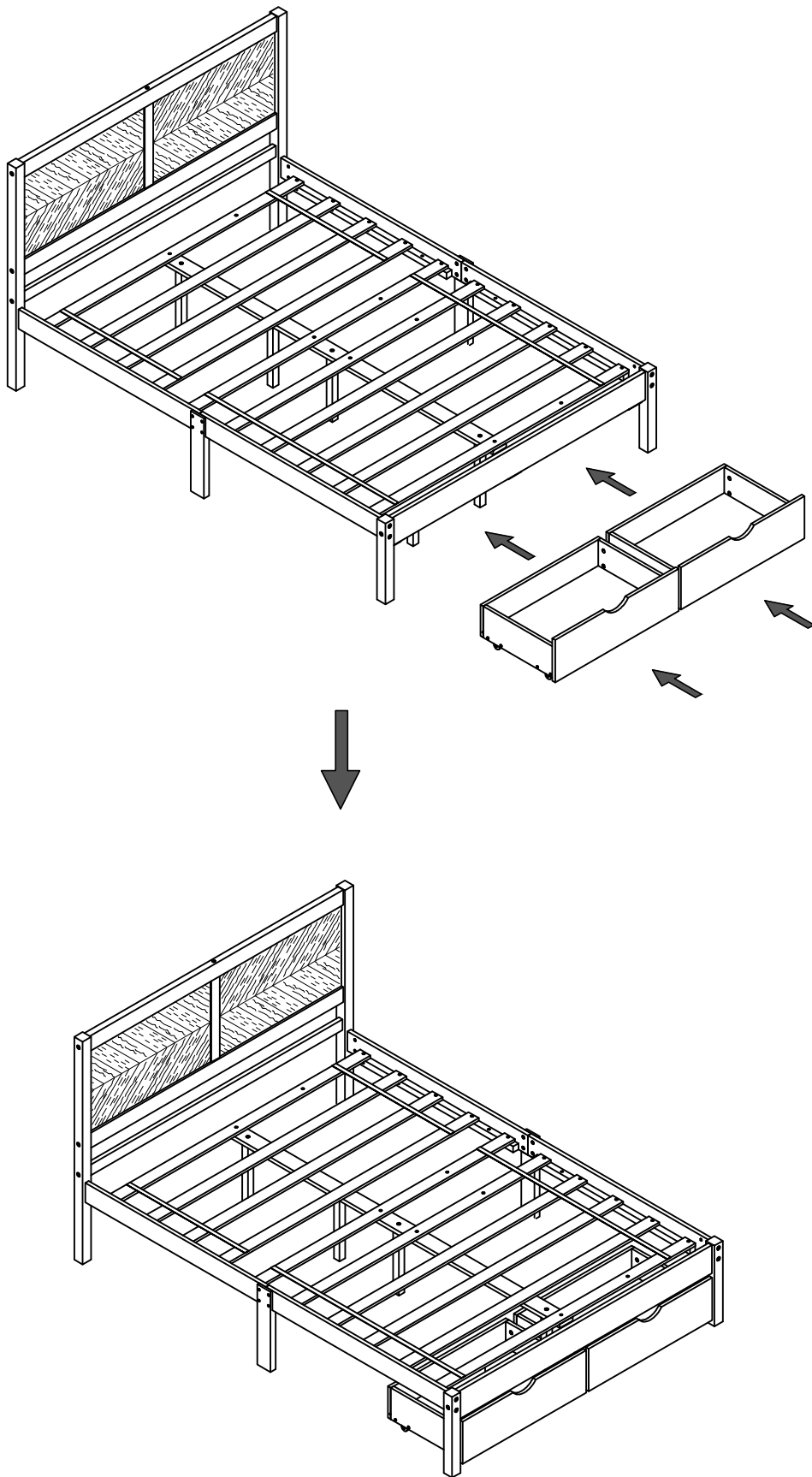

1		8	
8PCS		16PCS	
		12	
		8PCS	

STEP 16:



STEP 17:

TYPE 2

4		7	
2PCS		2PCS	

Please assemble B7 if you have purchased the electric bed. However, if you have not, you can ignore this step.

