

Assembly Instructions

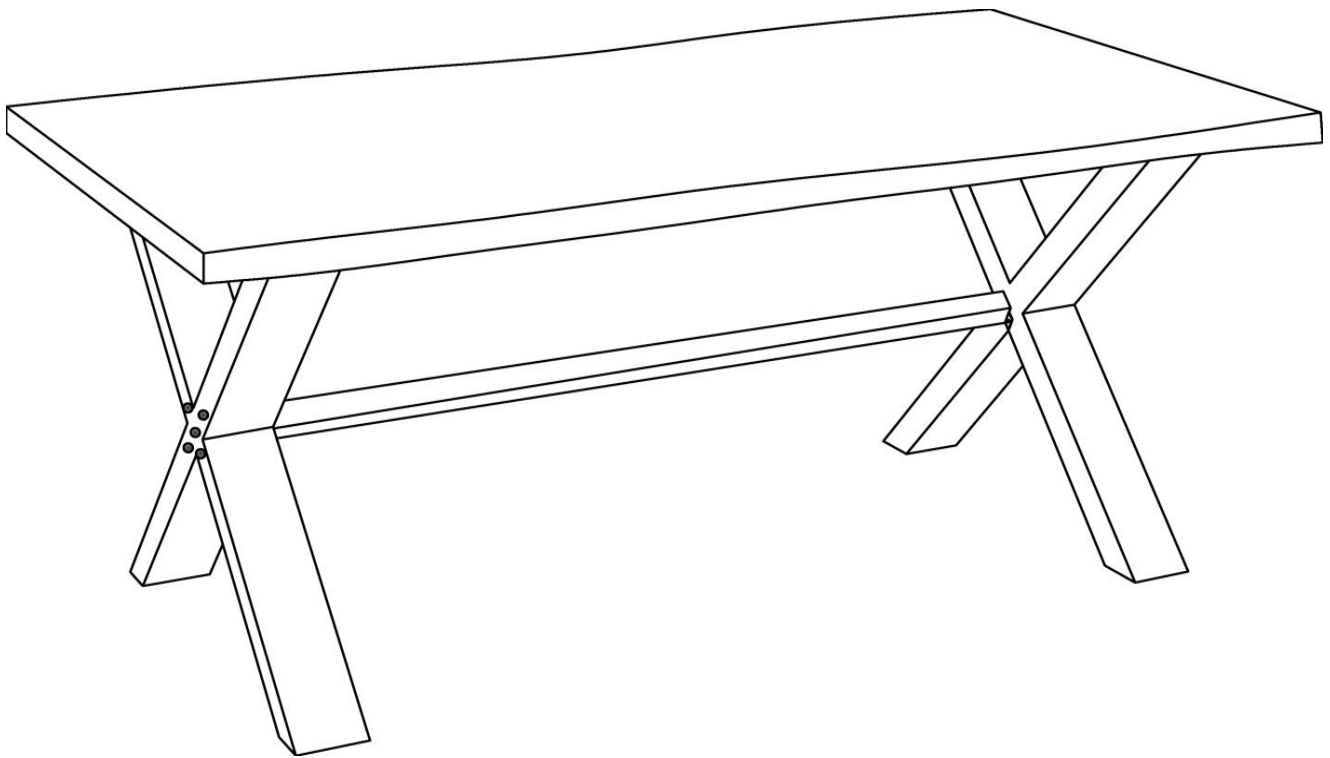

TABLE

CAUTION: You must read this before you proceed.



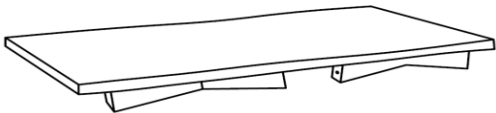

This table assimilates the shape of Tree Trunk at the long sides of the table. Therefore, the long sides of the table is irregular in shape and is the intended design.

Parts List

No.	Picture	Description	Qty
A		Table Top (with folded legs)	1
B		Support Bar	1





Hardware

No.	Picture	Description	Qty
C		Bolt (M8x25mm)	13
D		Washer (M8.5/16x2mm)	13
E		Spanner Wrench	1

Assembly Preparation

Before Beginning Assembly:



-  Read instructions, cover to cover.
-  Have 2 adults on hand for assembly.
-  Do not assemble on flooring or carpet.
-  Assemble on a clean non-marring surface (packing foam).
-  Save all packaging until finished.

Assembly Steps

OVERVIEW

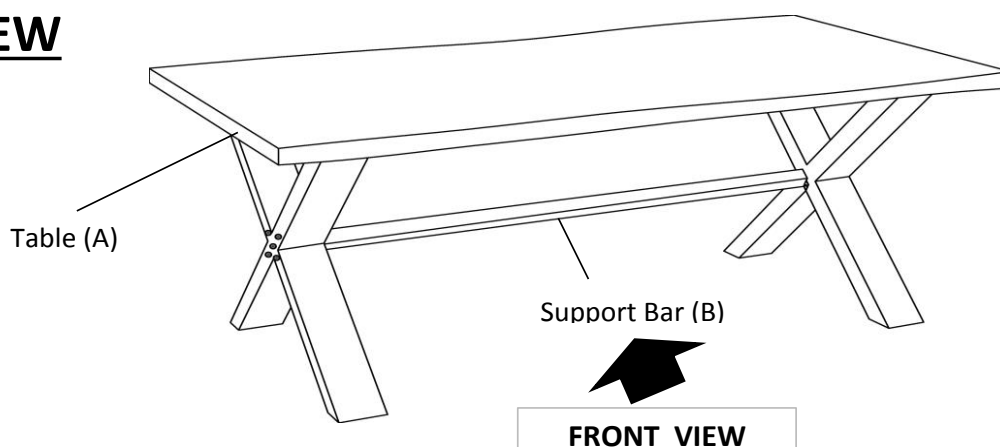

This Table has multiple parts and may require up to some 15 minutes to assemble. To give you an overview of the Table parts, the above picture is to help you put the various parts into perspective. Please read through the instructions here below to familiarise the parts and steps before assembly.

Step 1

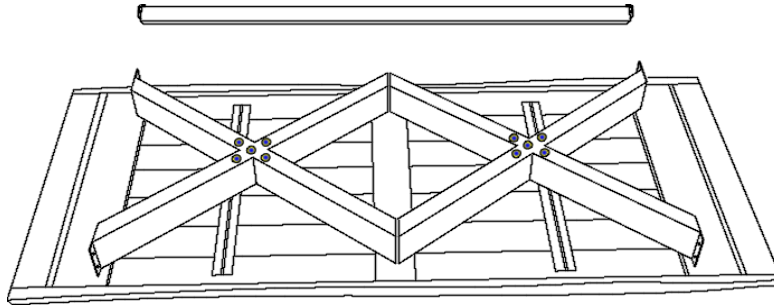

Unpack and place all parts on a clean non marring flat surface .

Step 2

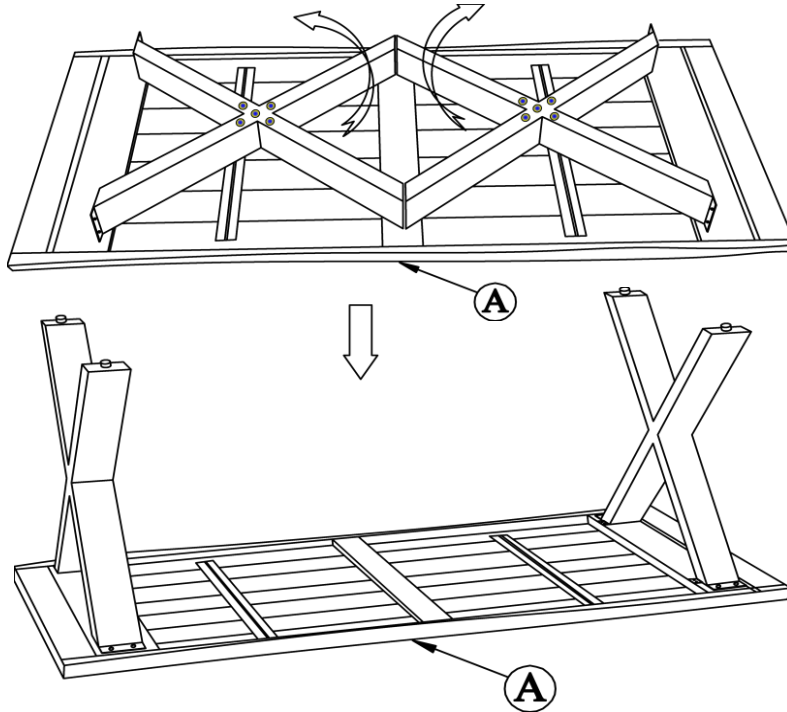

Place the Table (A) facedown, onto a clean, soft surface to avoid any scratches or damages to the product.

Lift legs upwards and outwards until the braces are met at position to the base of the table, as shown in the above pictures.

Step 3

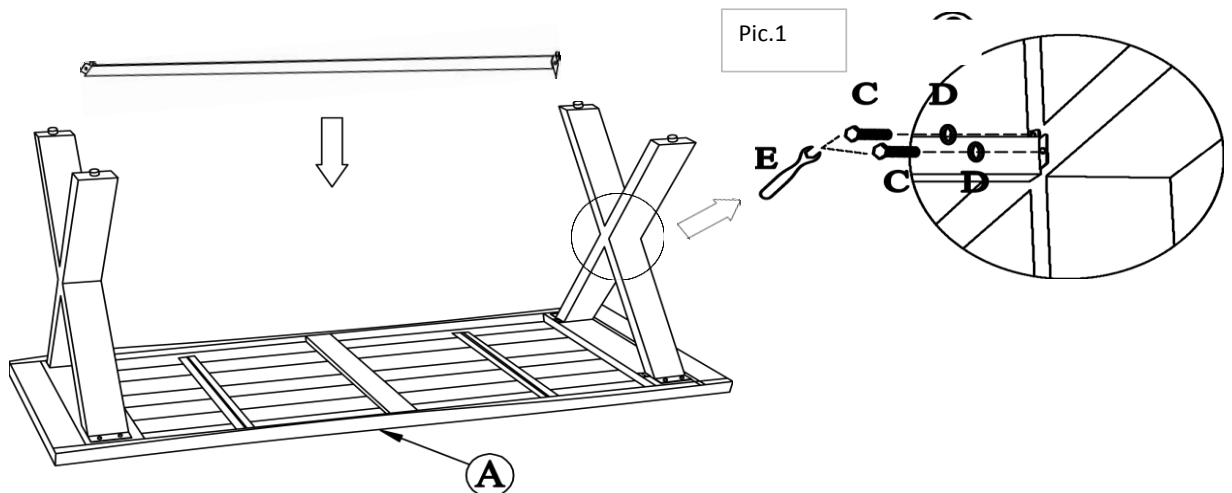

Attach the Support Bar (B) to the Table (A)

You may need to apply a little pressure to the Legs - pushing outwards, so as to enable the Support Bar (B) to be slotted into position.

Using Bolts (C) with Flat Washers (D), tighten the Bolts by using Spanner Wrench (E), as shown in Pic.1

Loosely tighten the Bolts, up to 80%.

Step 4

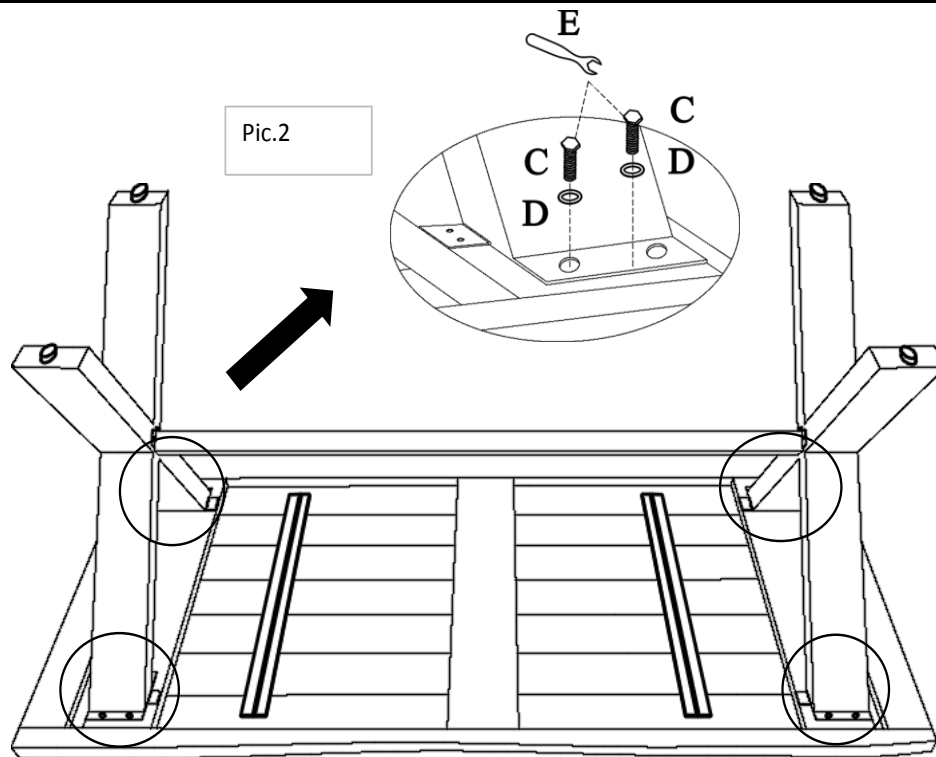

Secure Legs to Table by using Bolts (C) and Flat Washers (D) with Spanner Wrench(E) as shown in Pic.2 above, at all 8 positions.

Loosely tighten these Bolts, up to 80%.

Turn it over, with assistance from your partner, stand to each of the longside of the table.

EXERT pressure, floorwards, onto the table.

This pressure will help the legs and table top to reach alignment at all joints.

Check for wobbleness.

Turn it over, and in a sequential manner, gradually tighten each Bolt until all bolts are evenly secured.

CAUTION: When tightening these screws, tighten sequentially.

DO NOT tighten any screw fully and then towards the next one. This would cause the frame to warp.

If there is still wobbles, loosen the screws and execute this same drop tests.

WARNING ! IF TABLE IS NOT STABLE , IT COULD LEAD TO DAMAGING THE PRODUCT.

Step 5

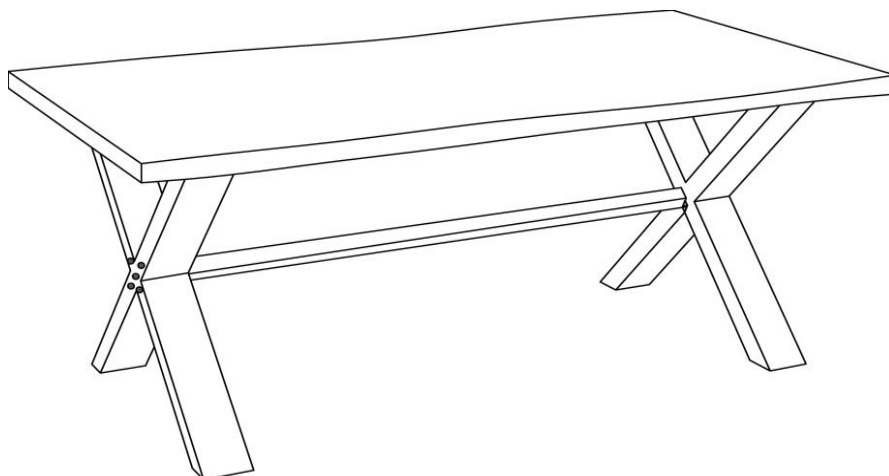









You are now at the FINAL stage of this assembly.

In a sequential manner, drive in and fully tighten all bolts.

Thereafter, turn the Table right way up.

The Table now is ready to be used

Care & Maintenance

- ⊘  ● Do not put hot items directly on furniture surface
 - ⊘  ● Do not clean furniture with harsh cleansers or polish.
 - ✓  ● To obtain the longest lifespan of your outdoor products, minimizing exposure to direct sunlight is recommended.
 - ⊘  ● Children should not climb or jump on the furniture.
 - ⊘  ● Do not write on furniture without a padded barrier to protect the surface.
 - ✓  ● To obtain the longest lifespan of your outdoor products, avoid extended and lengthy exposure to rain, snow, and direct sunshine. Whenever possible cover the product and /or place under patio or awnings.
 - ⊘  ● Not for commercial use. For residential use only .
 - ⊘  ● Stains may be removed with mild soap solution and damp cloth.
-
- ✓  ● Dust and pick-up spills using a clean, non-colored, lint-free cloth .