







CARE AND MAINTENANCE

Wipe clean with a soft, dry cloth. The seat board can be cleaned with a mild cleaner. Test the cleaning method on a hidden area before using them over the entire area.

NOTICE

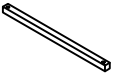
- * Please make sure that you have all parts indicated before you begin assembly of this item.
- * This item should be assembled on a soft surface to prevent scratching the finished product during assembly.
- * This item may require periodic tightening.
- * Do not tighten bolts until completely assembled.

Part List and Hardware List

Piece	Description	Picture	Quantity
A	CABINET		1 X
B	SIDE FRAME		2 X
C	CONNECTING BAR		2 X
HW1	HEX SOCKET BOLT 1/4"-20 * 1/2"		8 X
HW2	ALLEN KEY 4mm		1 X
HW3	ANTI-TIP HARDWARE		1 X

Product Dimensions:23"W x 16"D x 21-1/2"H.

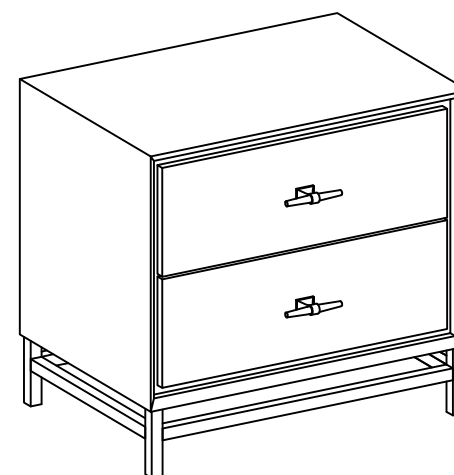

Weight Capacity : 25 lbs on top of the product
Warning : Do not stand on the product
Warning : Do not over torque bolts

PREPARATION

Before beginning assembly of product, make sure all parts are present. Compare parts with package contents list and hardware contents list. If any part is missing or damaged, do not attempt to assemble the product.

Estimated Assembly Time: 15 minutes.

Tools Required for Assembly (included): Allen key.

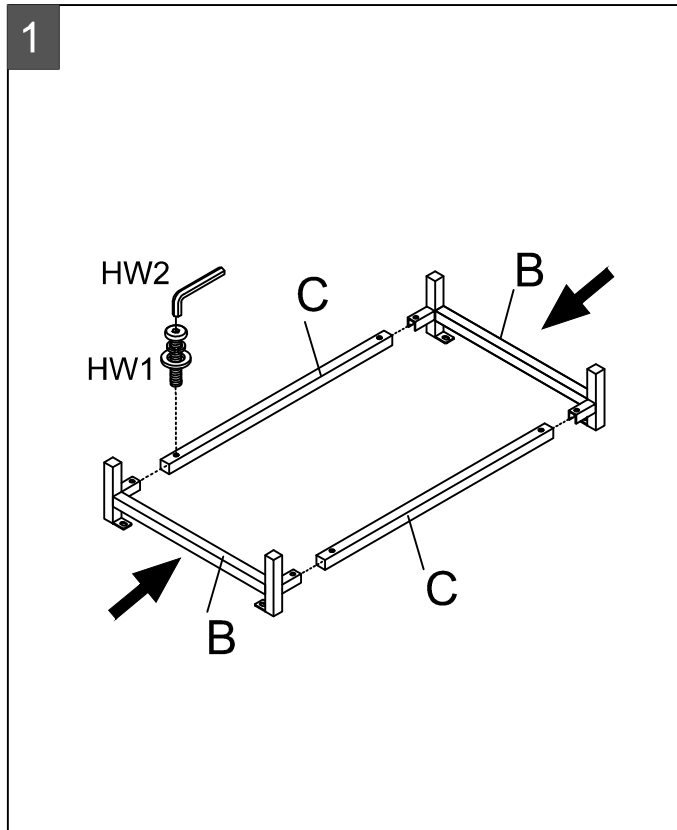

Step 1:
Insert the protrusions on the 2*Side frames (B) into the tube of Connecting bar (C). Using the Allen Key (HW2) to lock with 4*Hex Socket Bolts (HW1).

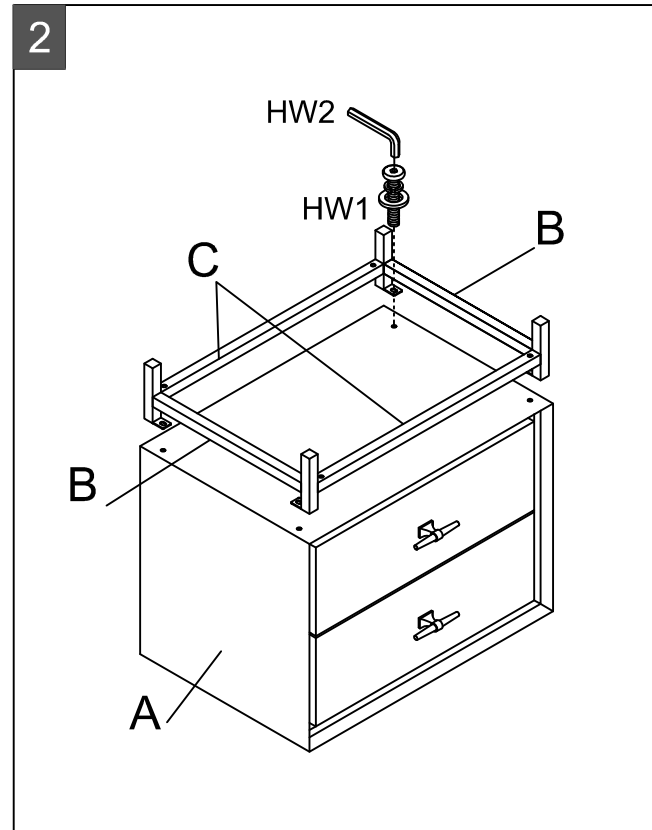

Step 2:
Attach the assembled metal base to underneath of cabinet(A), using Allen Key (HW2) to lock with 4*Hex socket bolts (HW1).

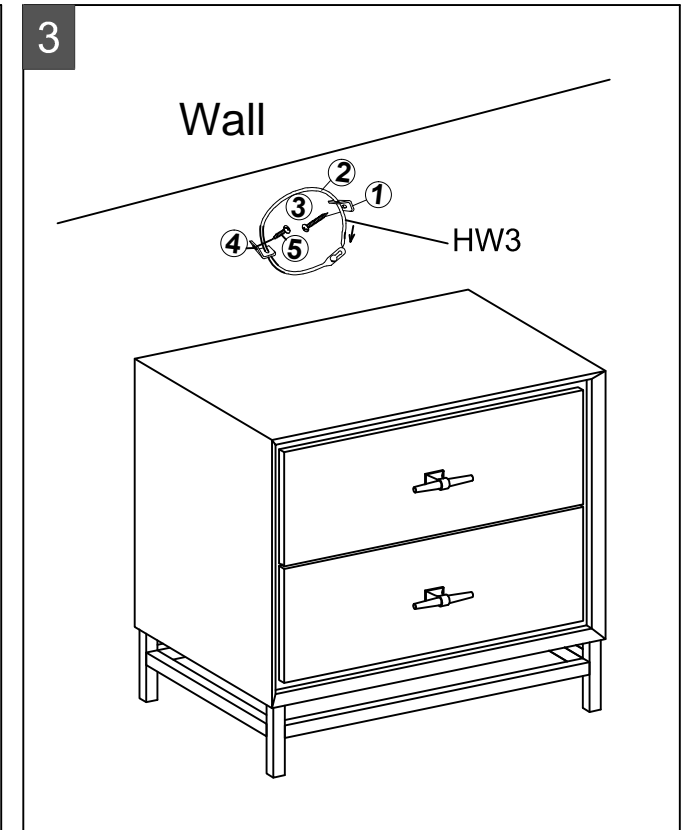

Step 3:
Straighten up the assembled product. Following the installations of Anti-Tip Hardware (HW3) to fix the product in the wall by 1 strap. Assembly is completed