

ASSEMBLY INSTRUCTIONS

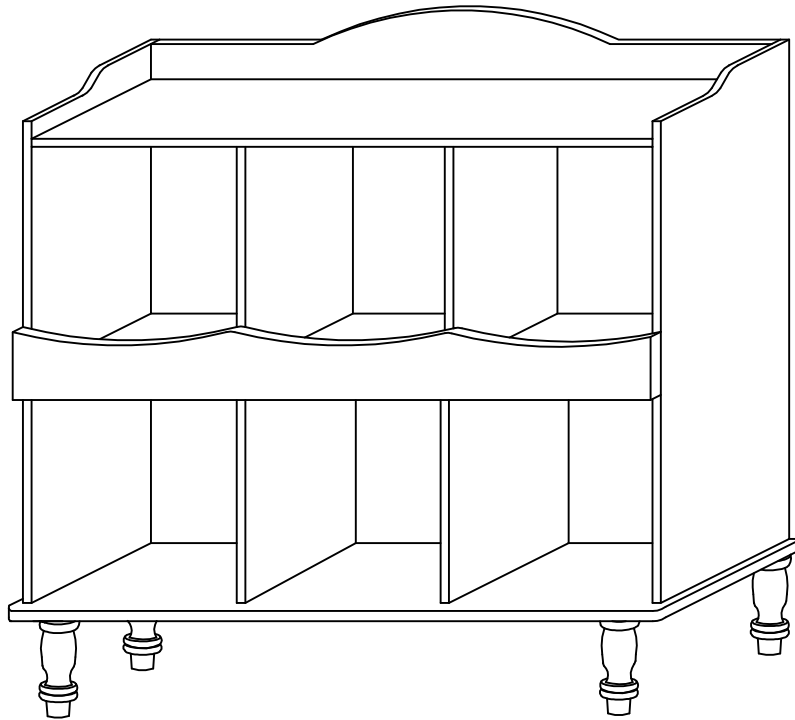



6 Cubby Storage Cabinet



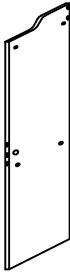
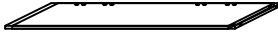

NOTE TO CUSTOMERS:

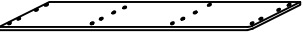
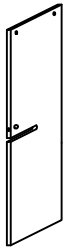
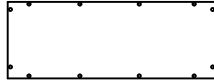
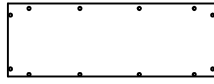
- For ease and speed of assembly we recommend that before you commence each step of the assembly that you identify all the parts required to complete that step.
- We recommend that where possible you allow sufficient space to assemble the item as close as possible to the place where it will be once assembled.
- For the protection of your furniture we recommend that the product is placed on protected surfaces during assembly to prevent any damage.
- During assembly do not over tighten ,as this may damage the product.
- Please ensure you retain all the product packaging until the item completely assembled.
- Please periodically check all fittings and re-tighten as necessary.
- Never allow any liquids to remain on your furniture as absorption can cause the wood to warp or the finish to de-laminate.
- It is recommended that this item should be assembled by two adults.

Part List

<p>A1(L&R). Quantity of 1</p>  <p>Apron</p>	<p>A2 (L&R). Quantity of 2</p>  <p>Side Panel</p>	<p>A3. Quantity of 1</p>  <p>Top Panel</p>	<p>A4. Quantity of 1</p>  <p>Shelf</p>
<p>A5. Quantity of 1</p>  <p>Bottom Panel</p>	<p>A6. Quantity of 2</p>  <p>Middle Divider</p>	<p>A7. Quantity of 1</p>  <p>Back Panel</p>	<p>A8. Quantity of 1</p>  <p>Back Panel</p>
<p>A9. Quantity of 4</p>  <p>Leg</p>	<p>A10. Quantity of 1</p>  <p>Scallop Panel</p>		

Hardware List

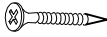
<p>B1. Quantity of 17</p>  <p>Wood Dowel</p>	<p>B2. Quantity of 18</p>  <p>Camlock</p>	<p>B3. Quantity of 23</p>  <p>Screw</p>	<p>B4. Quantity of 11</p>  <p>Screw</p>
---	--	---	--

APPENDIX: Dimension of Hardwares in this A1.

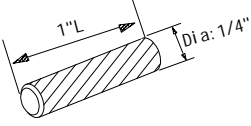
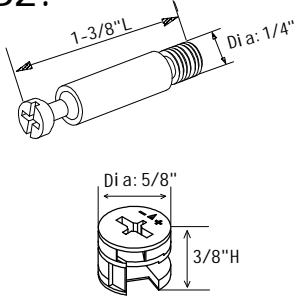
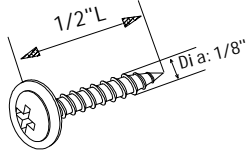
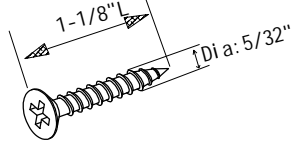
<p>B1.</p> 	<p>B2.</p> 	<p>B3.</p> 	<p>B4.</p> 
--	--	---	--

Note:

- Read these instructions carefully before assembling.
- Tools required : Phillips screwdriver, flat screwdriver.
- Find a clean, smooth area on which to work , such as a carpet, in order to avoid scratching the wood surfaces.
- Wait to dispose of the packing material until assembly is complete and all parts and hardware are accounted for.
- Two or more people might be required for assembly.

To use Dowels:

1. Add glue (about $\frac{1}{4}$ full) in the hole(s) of each board to be joined.
2. Insert the Dowel(s) and join boards.
3. Wipe excess glue with a damp paper towel.

To use Cam Locks:

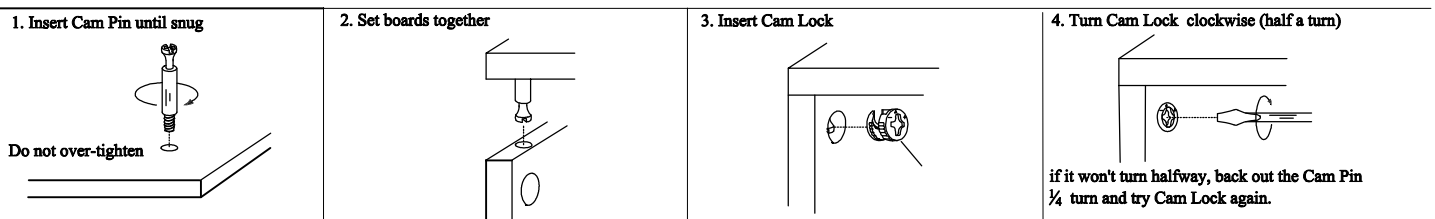

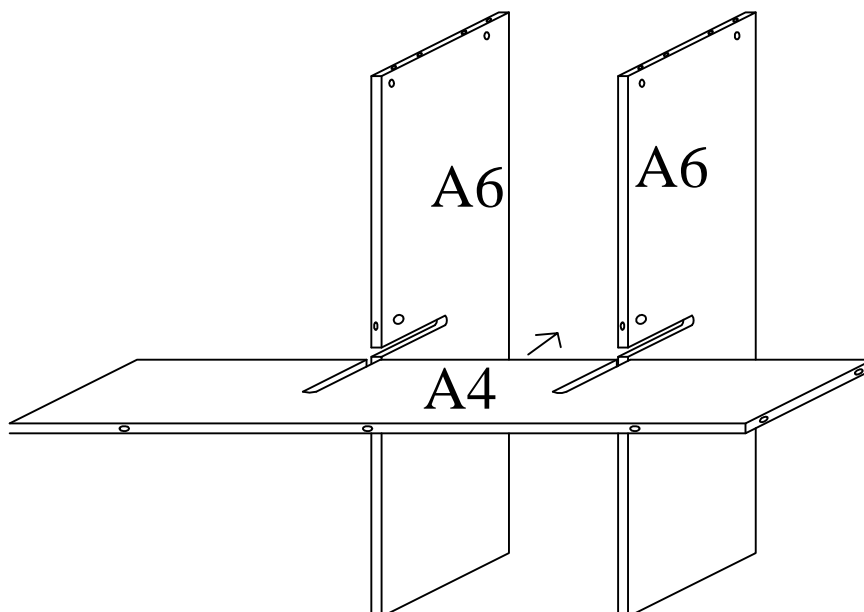

Step 1



Insert Shelf A4 into the grooves on Middle Dividers A6.

Step 2

B1		2pcs
B4		3pcs

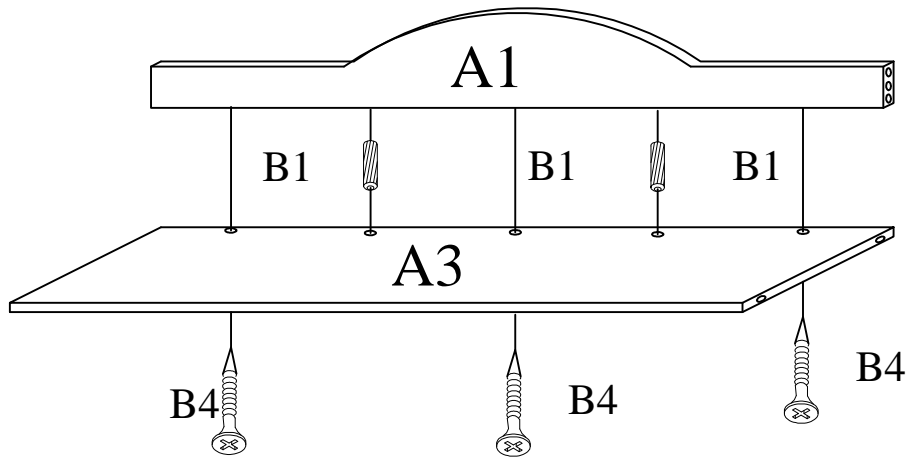

Attach Apron A1 to Top Panel A3 using Screws B4 and Wood Dowels B1.

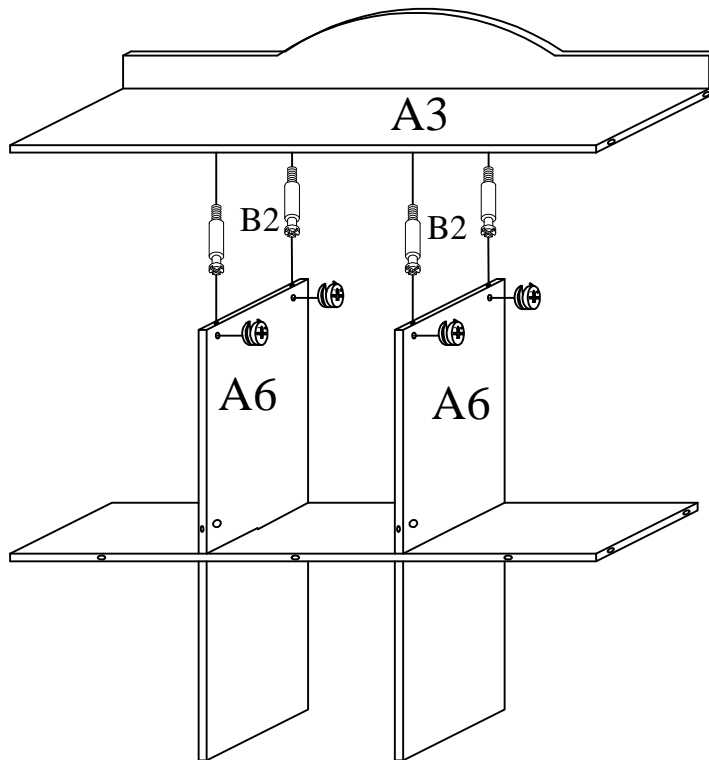

Step 3

B2		4sets
----	---	-------



Attach Top Panel A3 to Middle Dividers A6 using Camlocks B2.

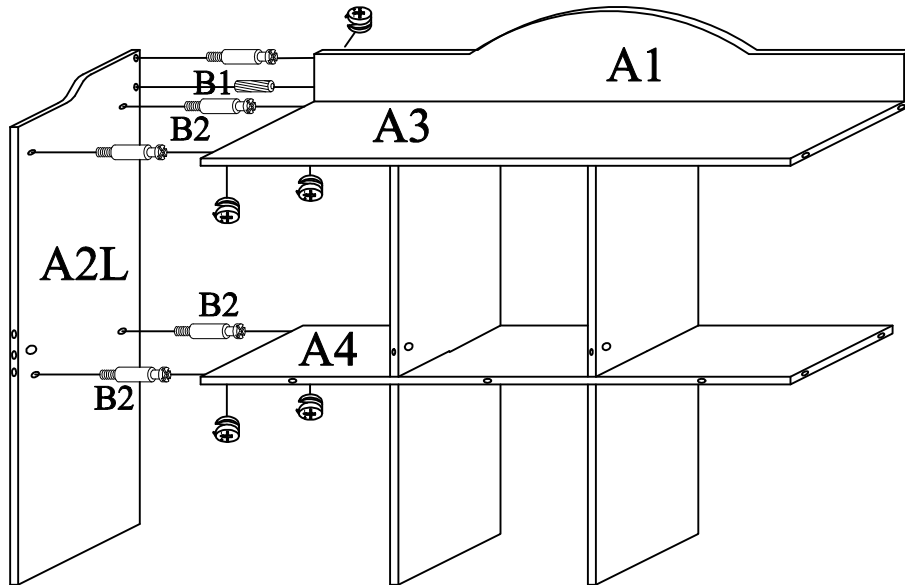

Step 4

B1  1pc
B2  5sets



Assemble Side Panel A2L to Apron A1, Top Panel A3 and Shelf A4 using Wood Dowel B1 and Camlocks B2.

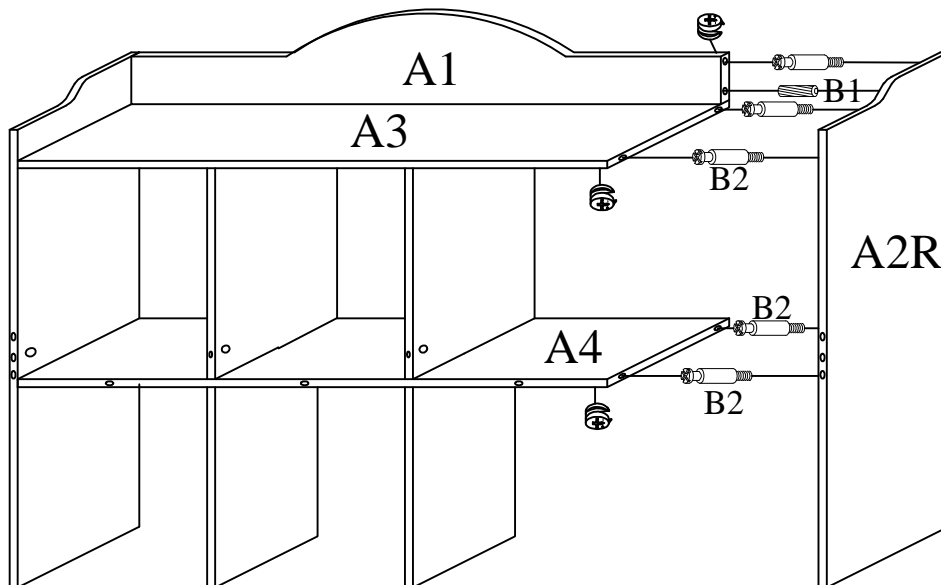

Step 5

B1  1pc
B2  5sets



Assemble Side Panel A2R to Apron A1, Top Panel A3 and Shelf A4 using Wood Dowel B1 and Camlocks B2.

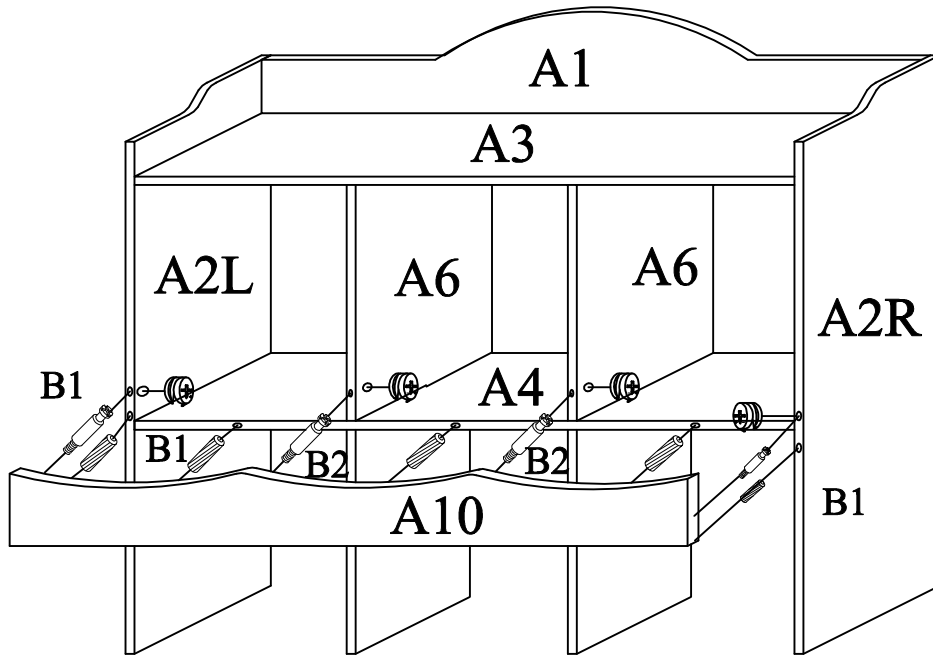

Step 6

B1		5 pcs
B2		4 sets



Attach Scallop Panel A10 to Side Panels A2(R&L) and Middle Divider A6 and Shelf A4 using Camlocks B2 and Wood Dowels B1.

Step 7

B1		8 pcs
B4		8 pcs

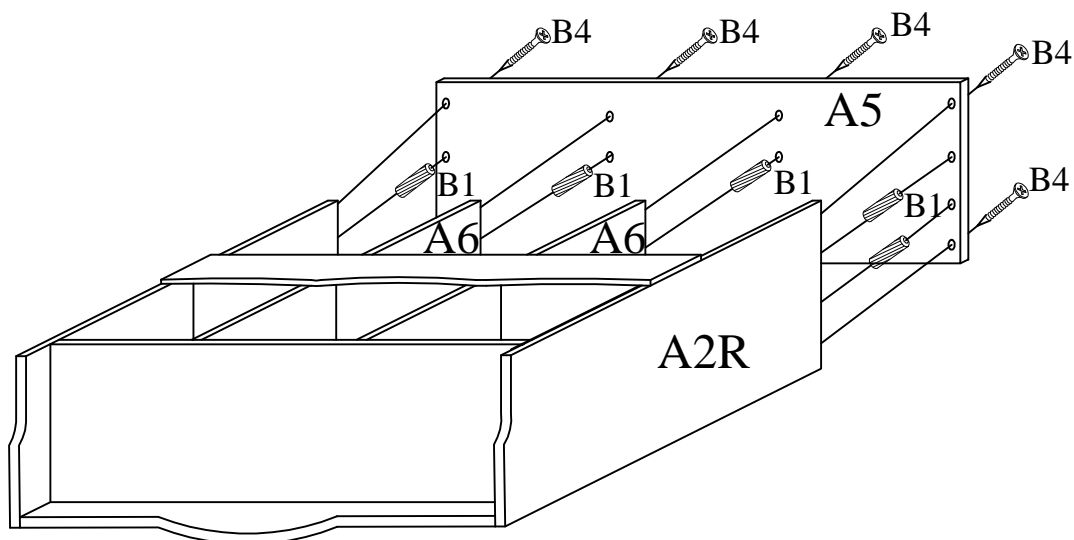

Assemble Bottom Panel A5 to Side Panels A2(R&L) and Middle Divider A6 using Screws B4 and Wood Dowels B1.

Recommend to attach the first 4 screws then turn over to attach the other screws.

Step 8

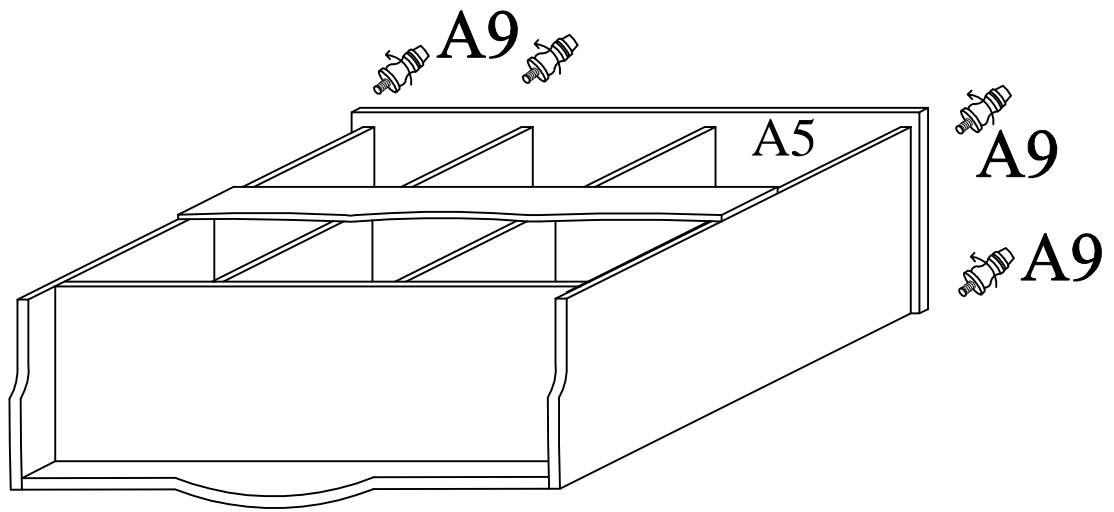

Screw Legs A9 to Bottom Panel A5.

Step 9

B3  23pcs

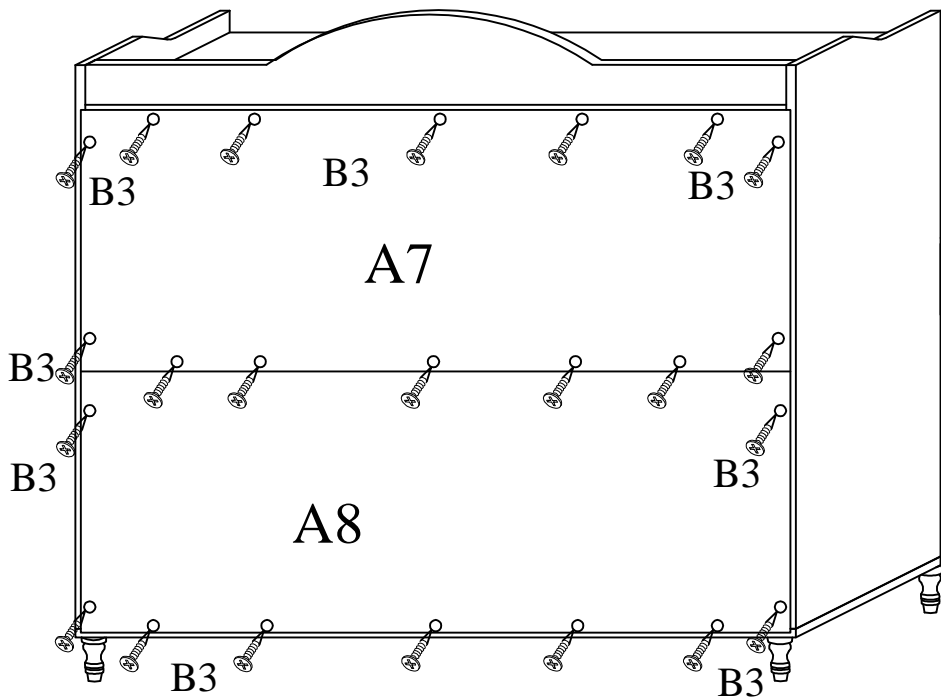

Attach Back Panels A7 and A8 to the cabinet using Screws B3.