

# USER MANUAL

---



CABINET

## TOOLS REQUIRED

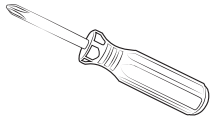

Phillips screwdriver  
(Not included )

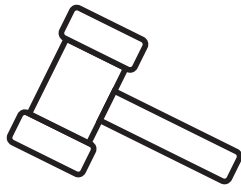

Hammer  
(Not included)

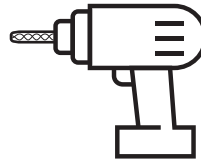

Drill  
(Not included)



Protective blanket  
(Not included)



## ATTENTION

Keep children and pets away while assembling.



# How to use cam locks

## CAM LOCK FASTENING SYSTEM

This Cam Lock Fastening System will be used throughout the assembly process.

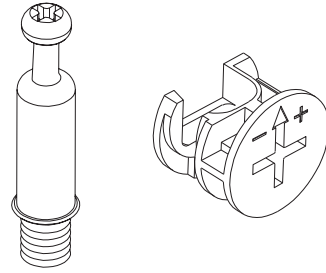

1

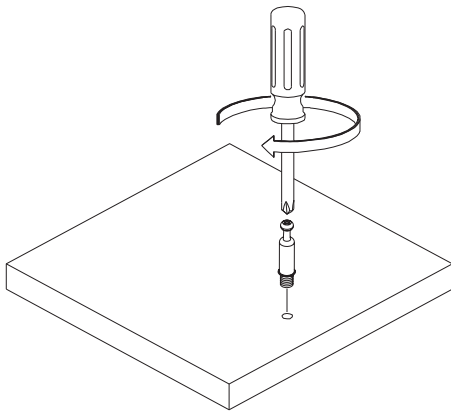

2

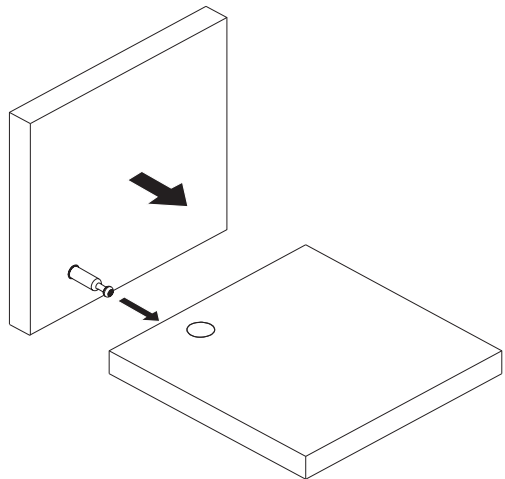

3

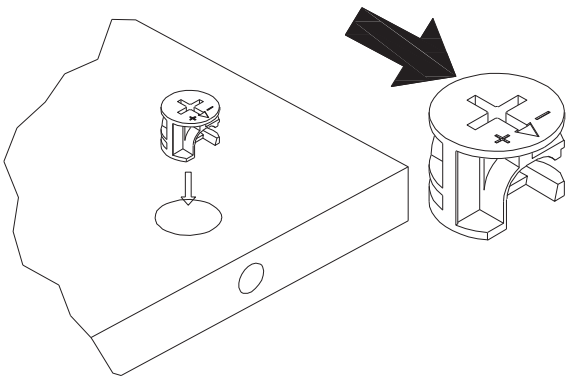

4

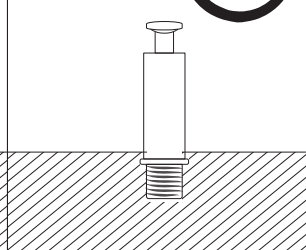
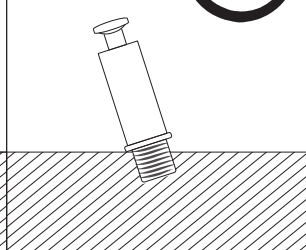
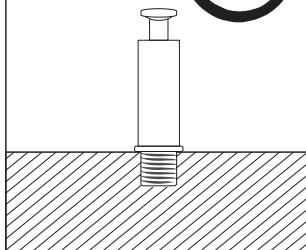
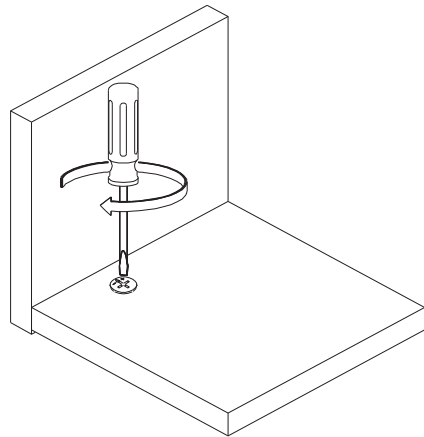

## INTRODUCTION

Thank you very much for choosing our product. Please read the instruction carefully before assembly and keep it for future reference. If you need further assistance on assembly, please contact our customer service through email.

---







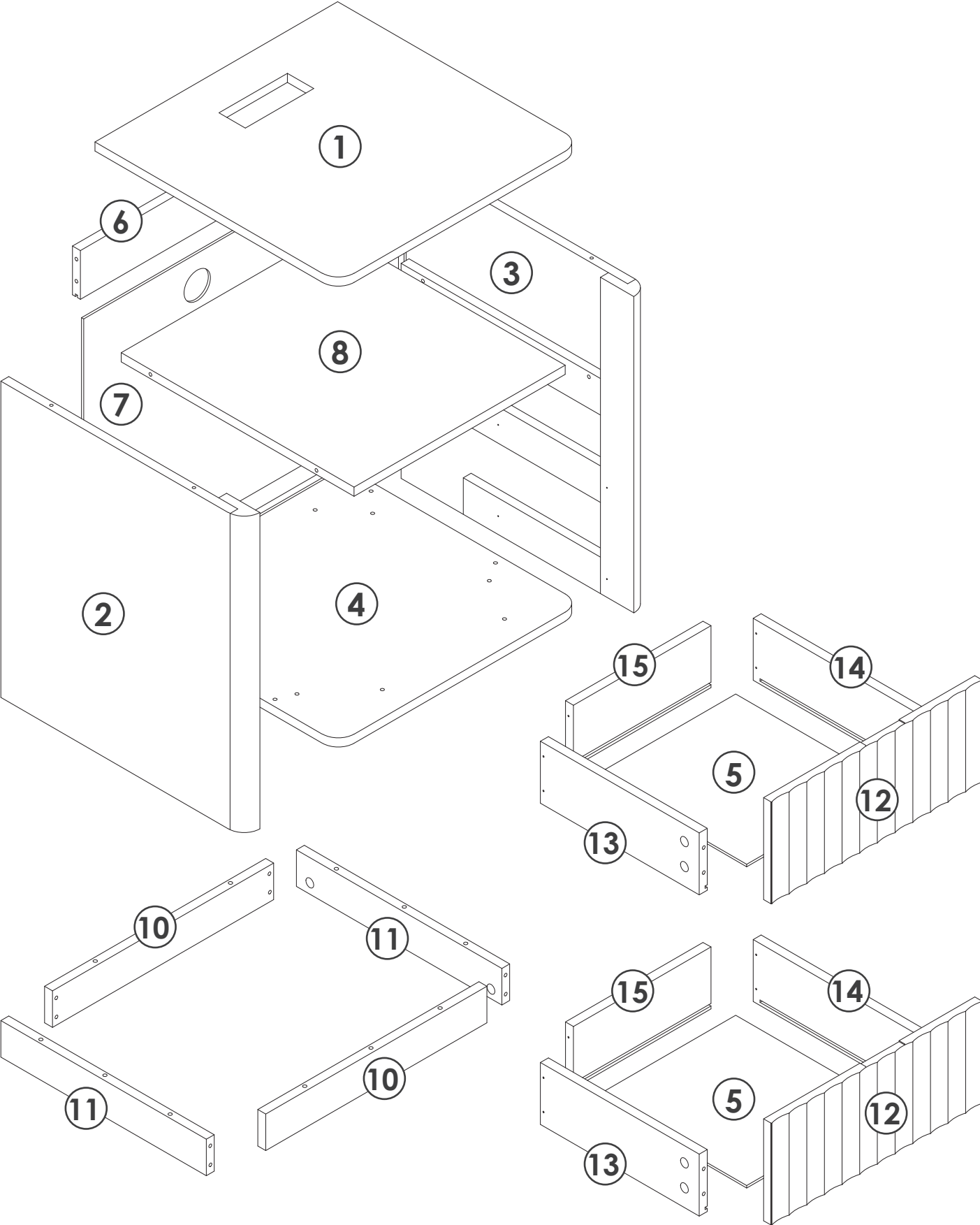

### **Tips:**

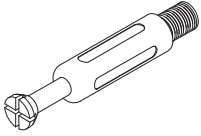
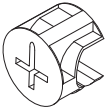
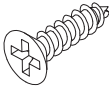
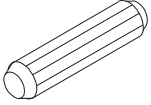
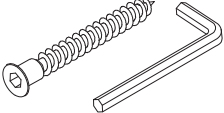
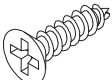
1. When installing the product, use a soft underlay (such as carpet or cardboard) to avoid scratching or damaging the surface of the product.
2. Don't tighten screws completely at first, just in case parts were assembled wrong and need disassemble. Tighten screws at last when all parts are put together.
3. The structure of this product can not meet the requirements of the placement of heavy items and children climbing.

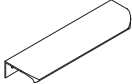
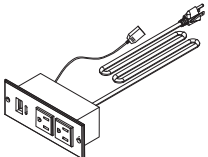
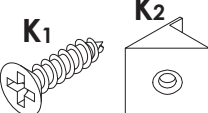
# HARDWARES LIST

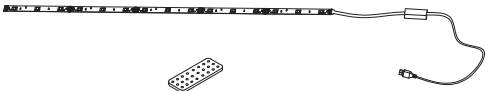

# PRODUCT ASSEMBLY

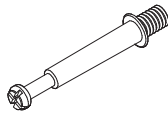
<p><b>A</b> x16</p>  <p>M6*40mm</p>	<p><b>B</b> x24</p>  <p>M15*11mm</p>	<p><b>C</b> x16</p>  <p>M3.5*14mm</p>	<p><b>D</b> x10</p>  <p>M8*40mm</p>
<p><b>E</b> x20</p>  <p>M5*40mm</p>	<p><b>F</b> x12</p>  <p>M3*12mm</p>	<p><b>G</b> x1</p> 	<p><b>H</b> x2</p> 
<p><b>J</b> x1</p> 	<p><b>K</b> x4</p> <p>K<sub>1</sub> K<sub>2</sub></p>  <p>M3*16mm</p>	<p><b>L</b> x18</p> 	<p><b>P</b> x4</p> 
<p><b>M</b> = CR + DR + CL + DL x2</p>  <p>12 INCHES</p>		<p><b>N</b> x1</p> 	
<p><b>Q</b> x3</p> 	<p><b>R</b> x8</p>  <p>M6*40mm</p>		

# INSTALLATION INSTRUCTION

---

$$M = CR + DR + CL + DL$$

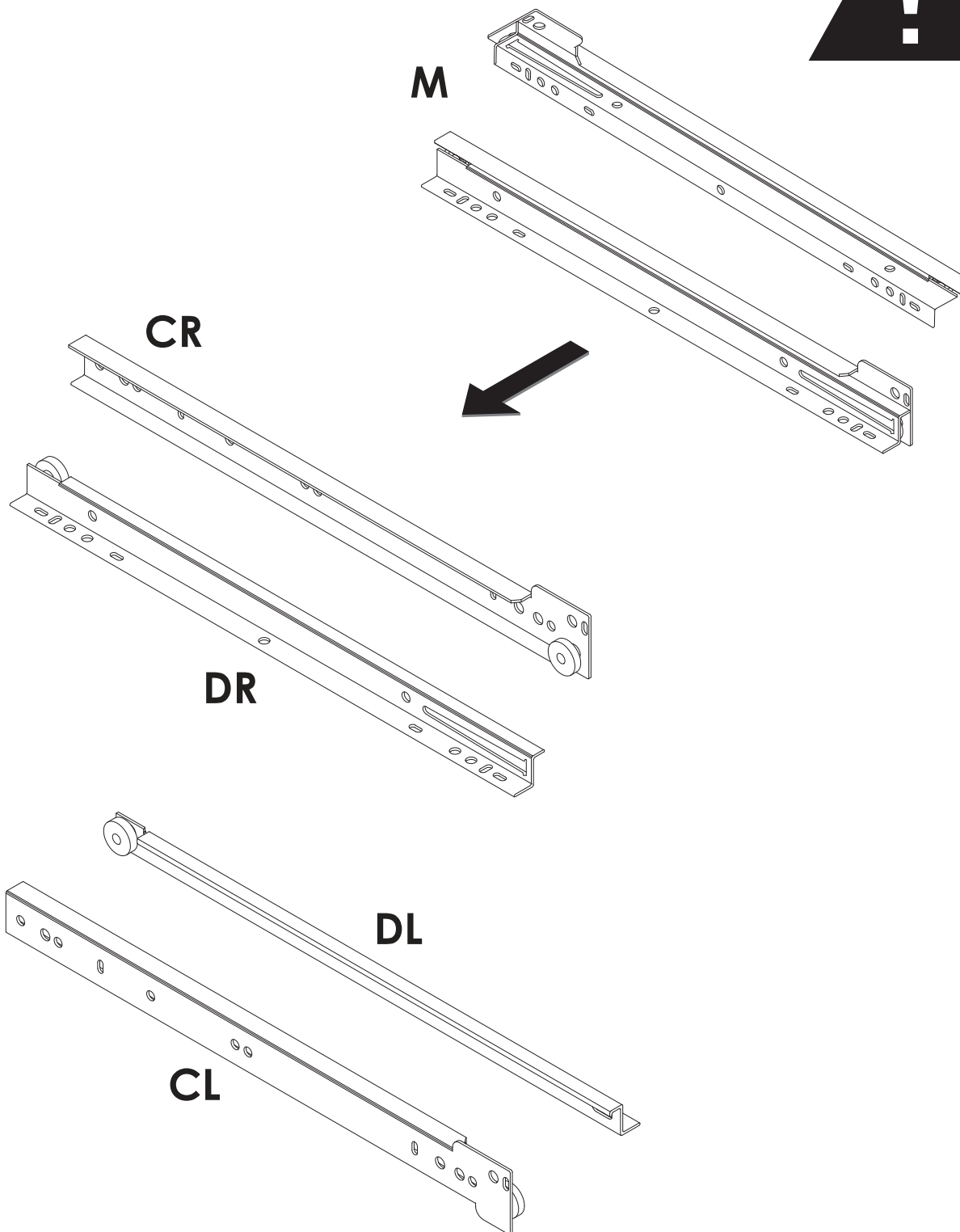

# 01

**A** x4pcs



M6\*40mm

**C** x4pcs



M3.5\*14mm

**M** x2pcs



CL

12 inches

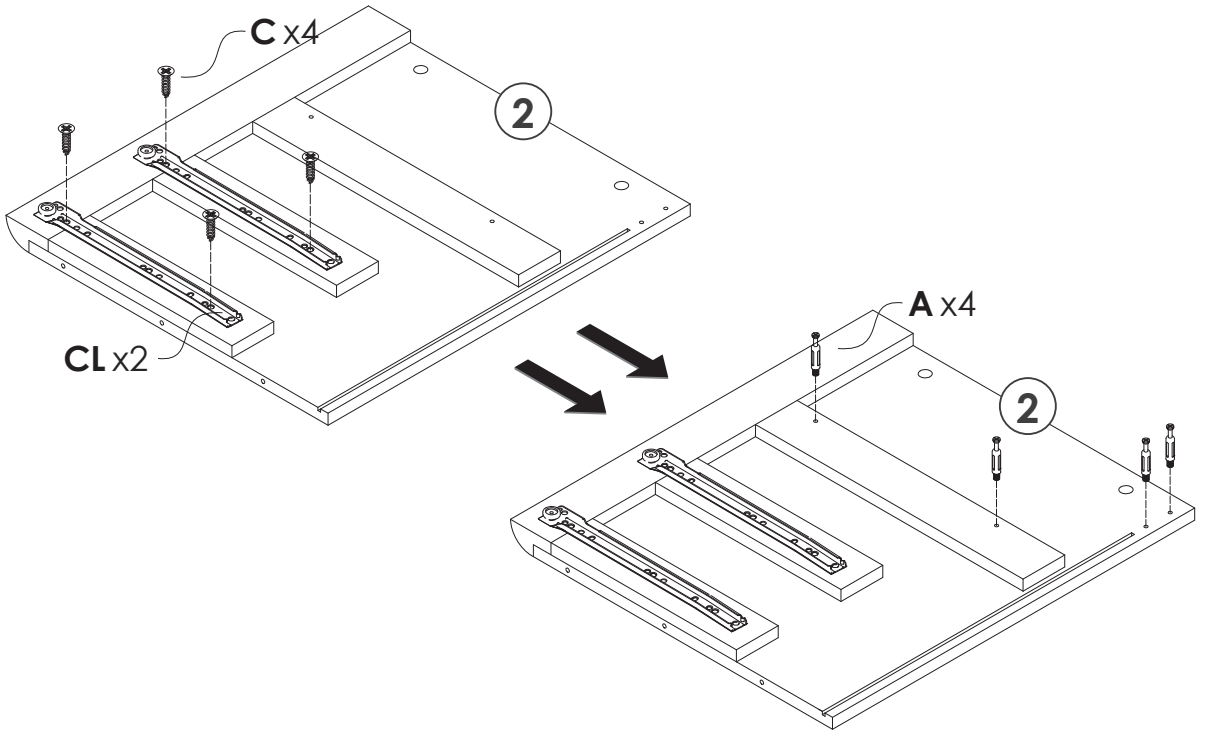
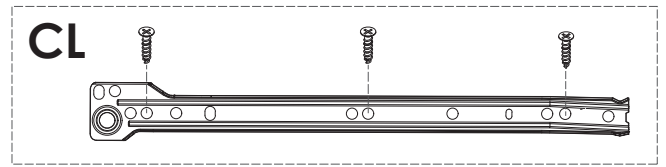

# 02

**A** x4pcs



M6\*40mm

**C** x4pcs



M3.5\*14mm

**M** x2pcs



CR

12 inches

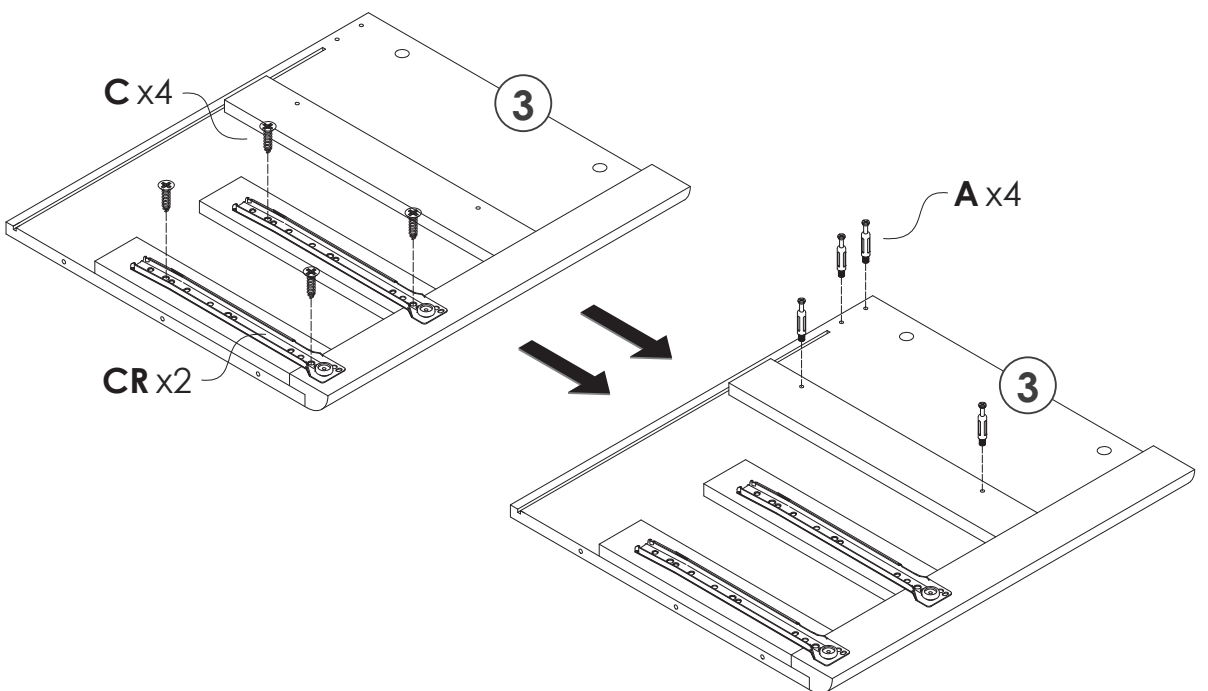
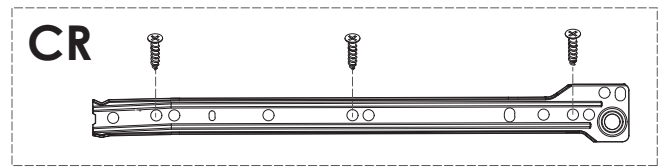

# 03

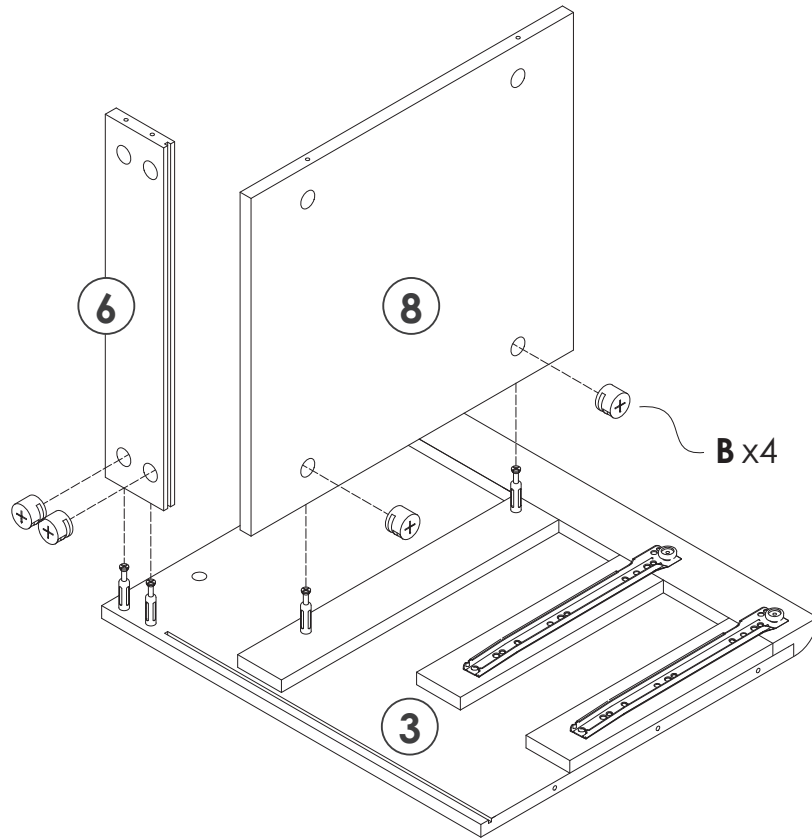
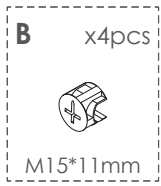

# 04

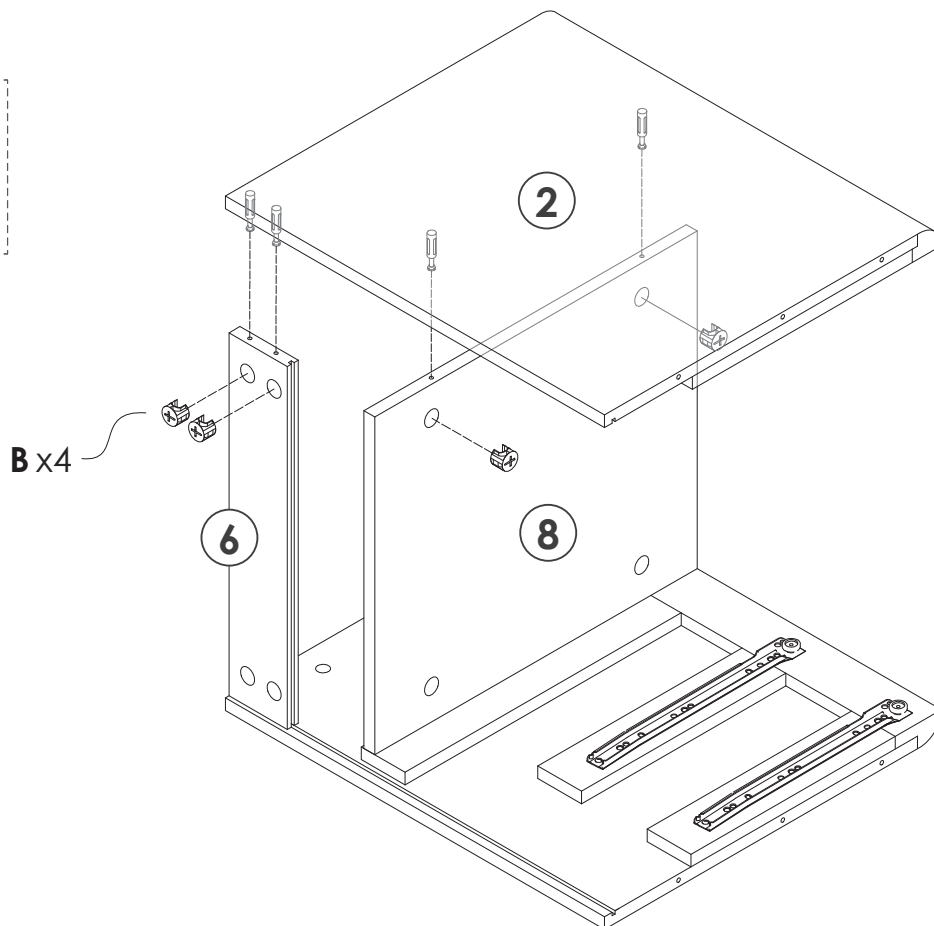
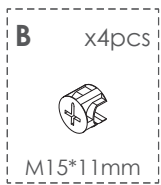

# 05

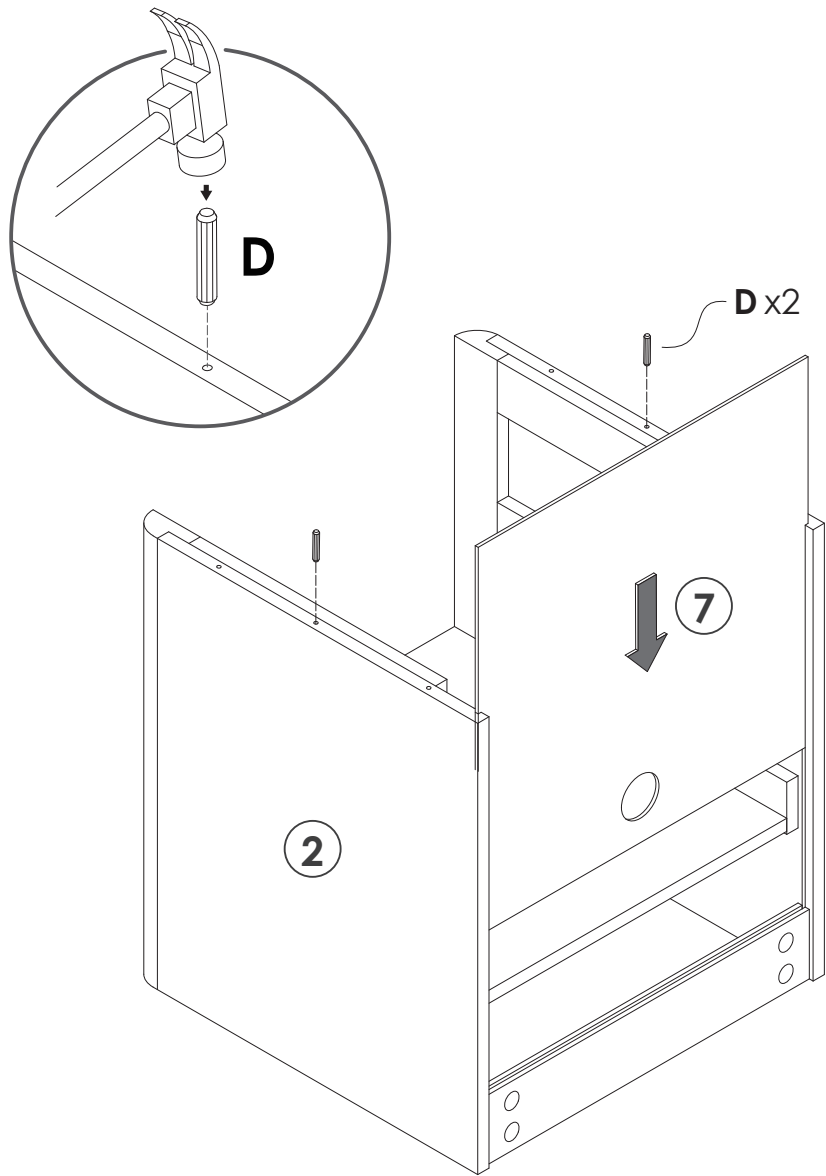
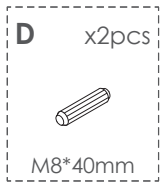

# 06

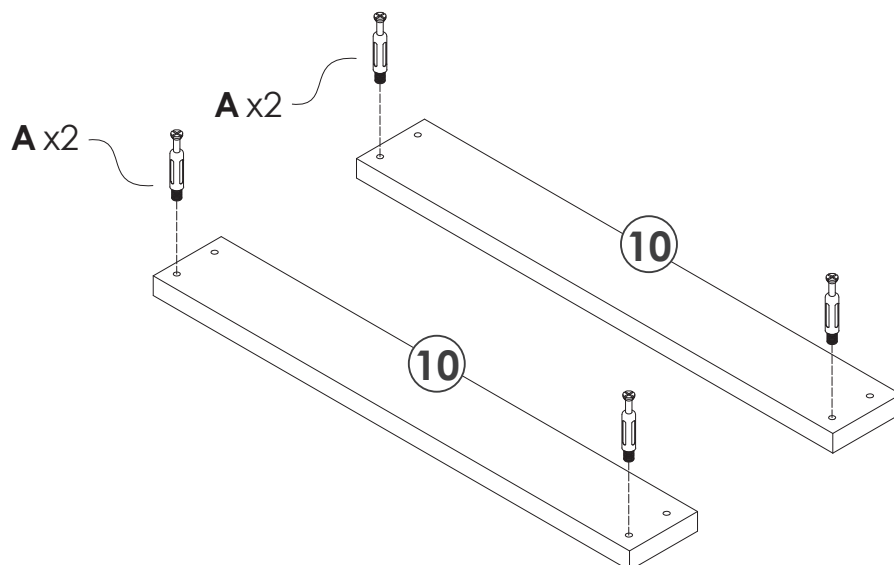
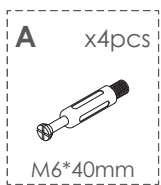

# 07

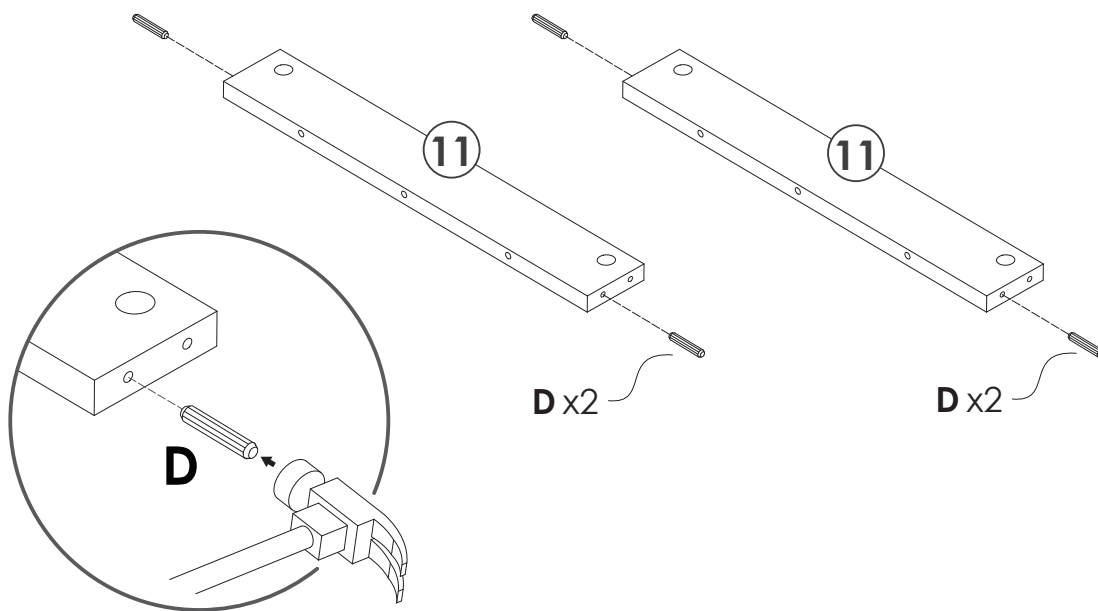
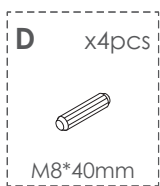

# 08

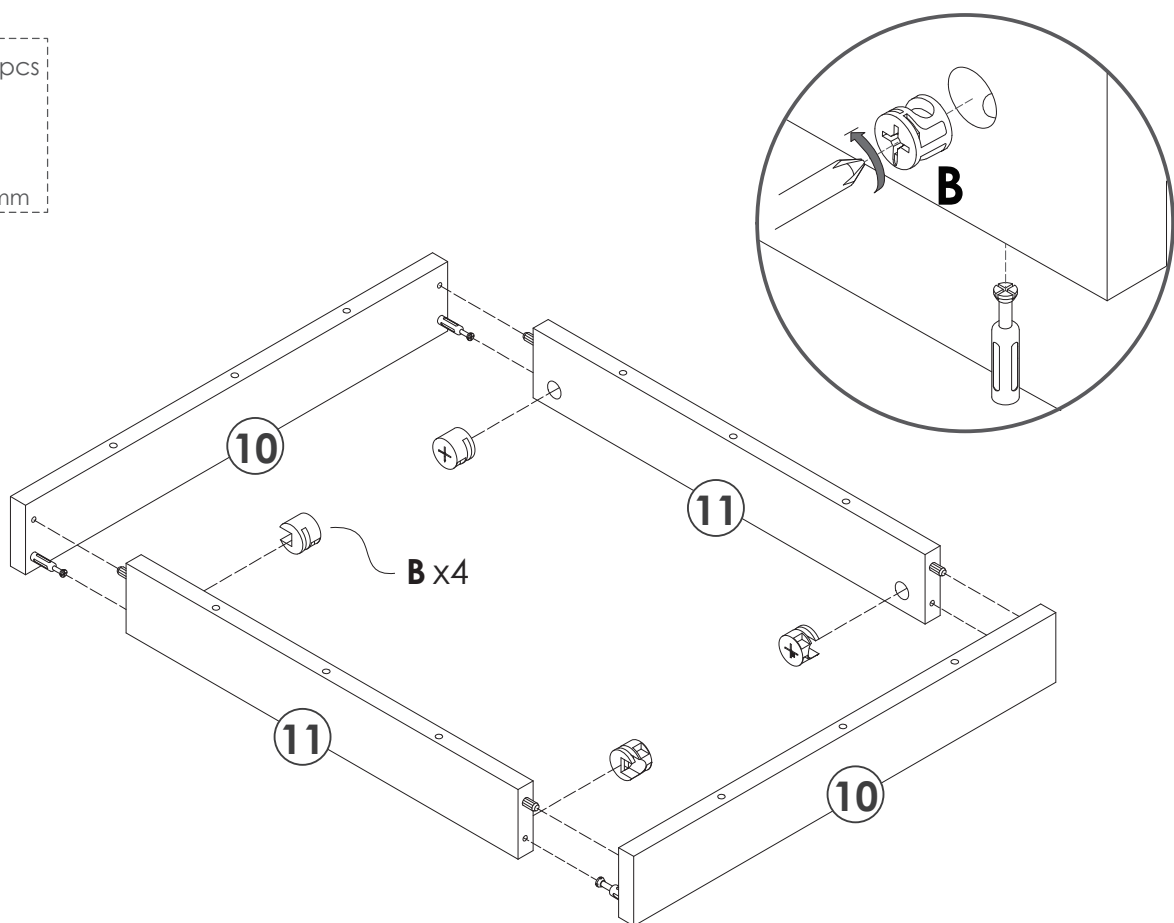
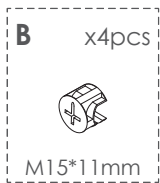

# 09

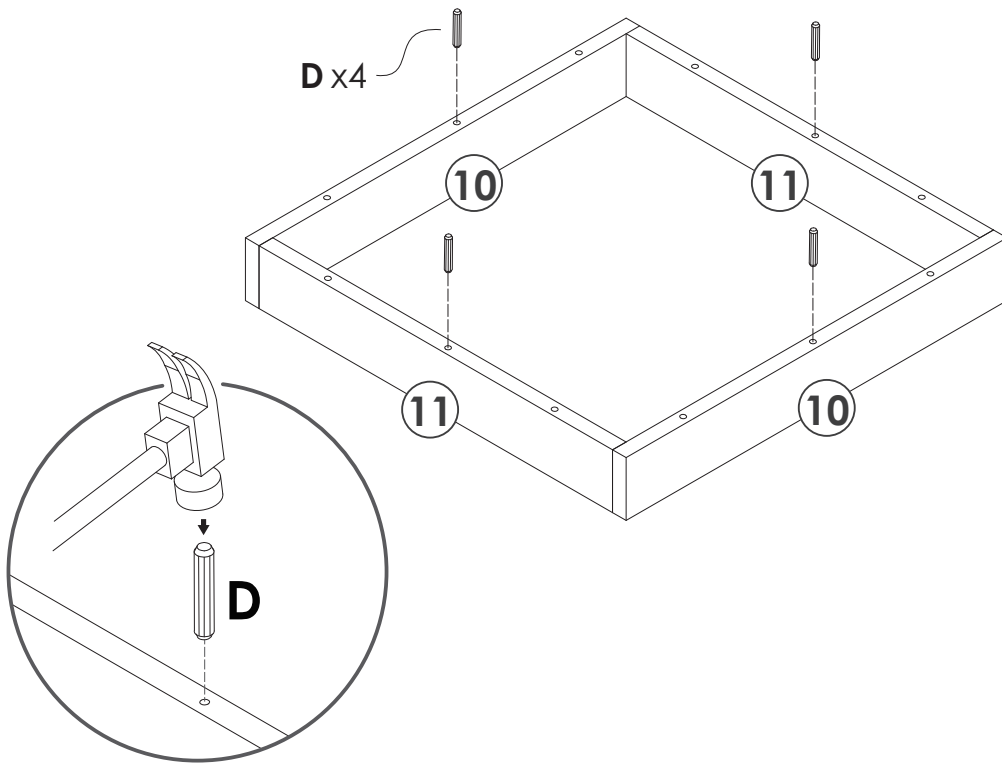
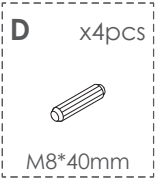

# 10

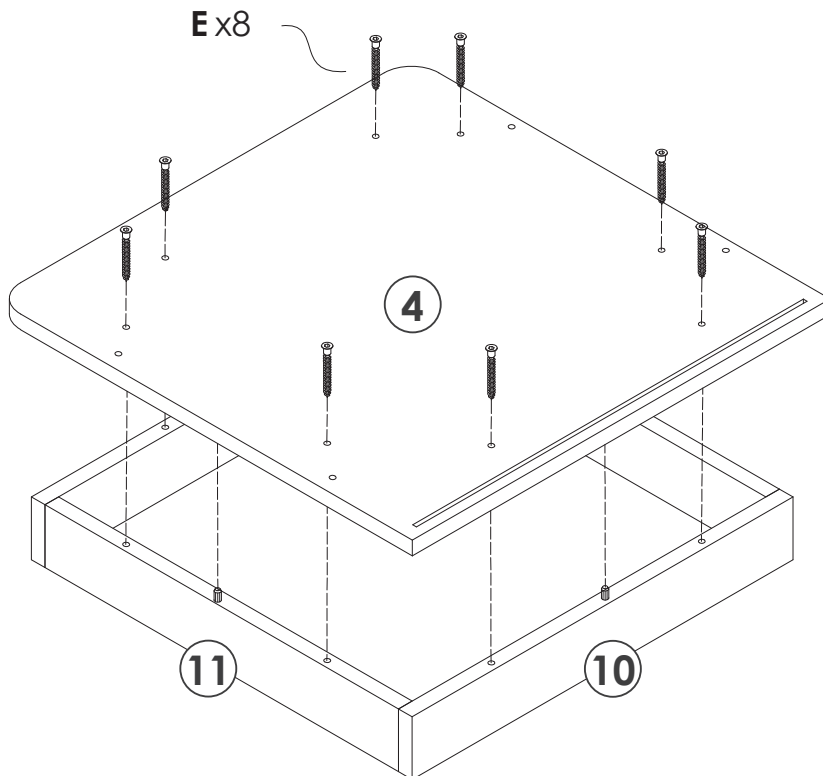
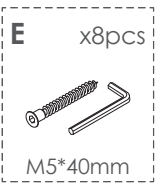

# 11

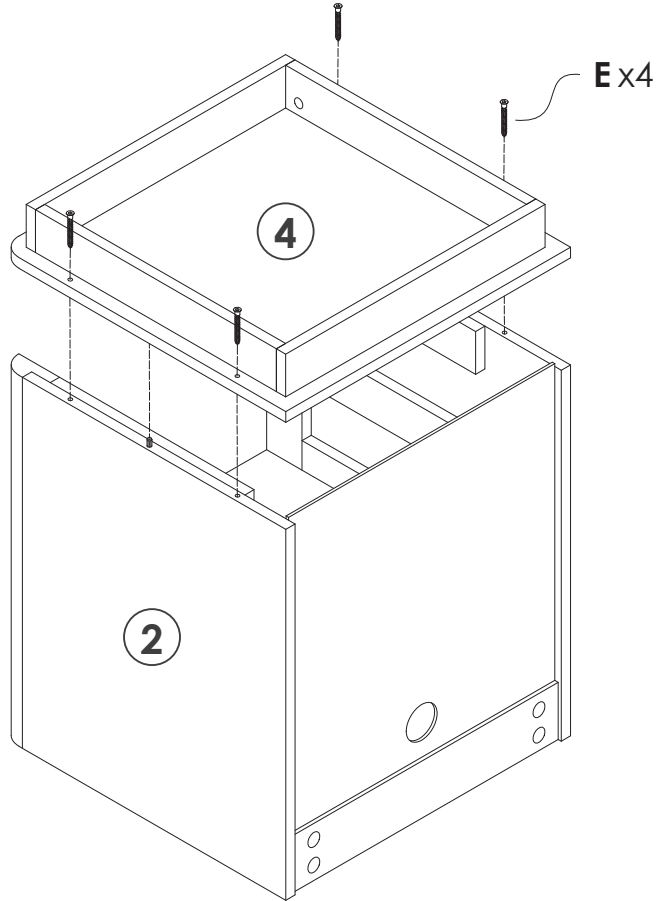
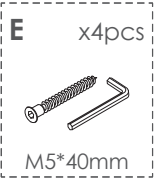

# 12

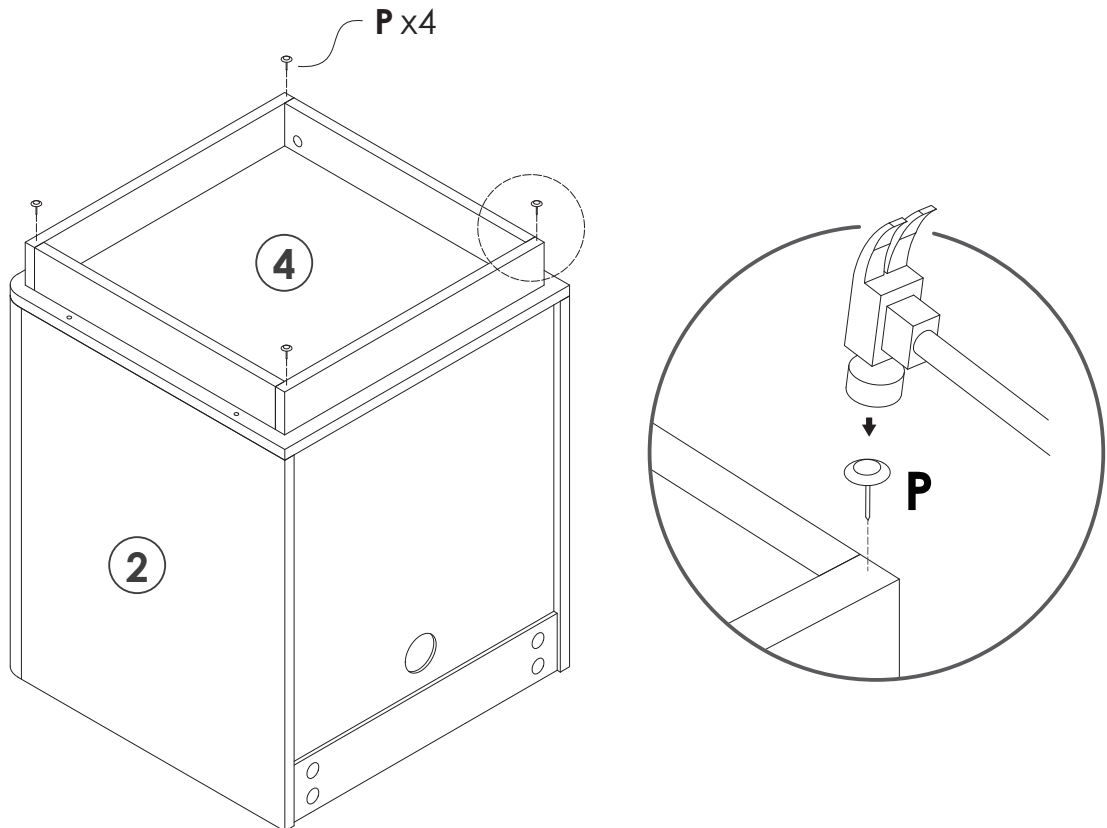
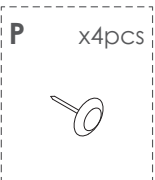

# 13

**A** x4pcs



M6\*40mm

**N** x1pc



**C** x6pcs



M3.5\*14mm

**Q** x3pcs

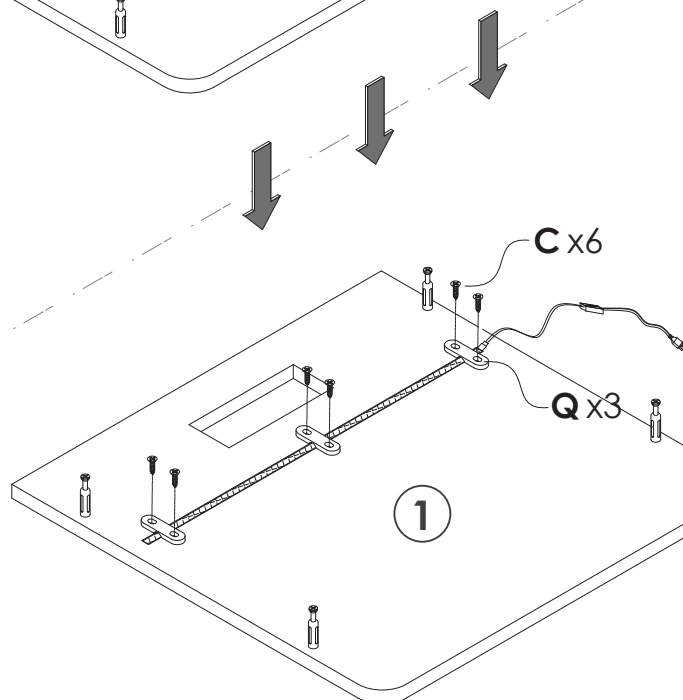
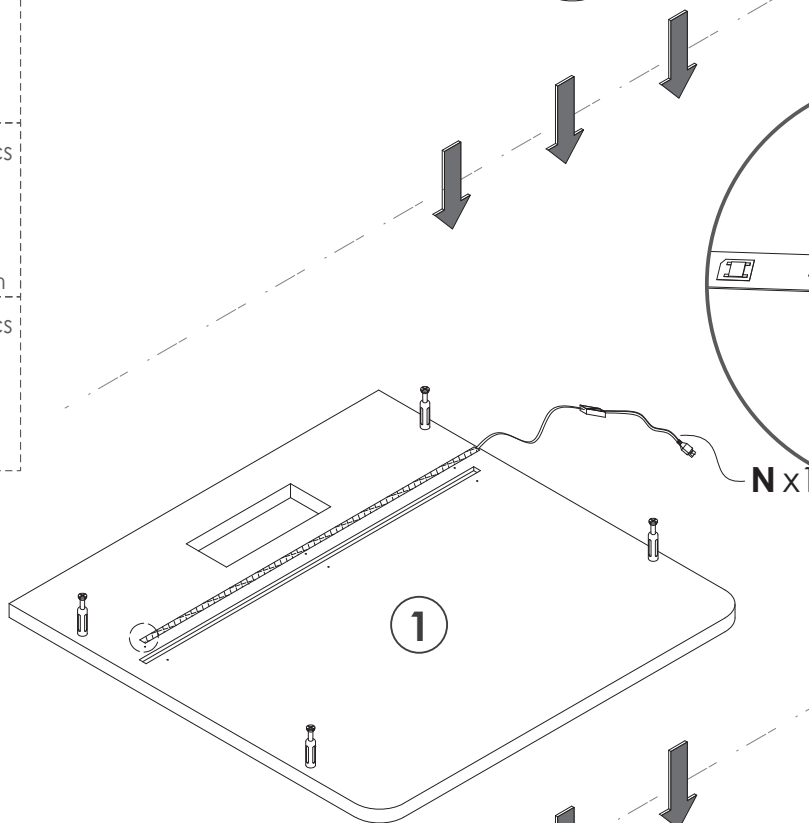
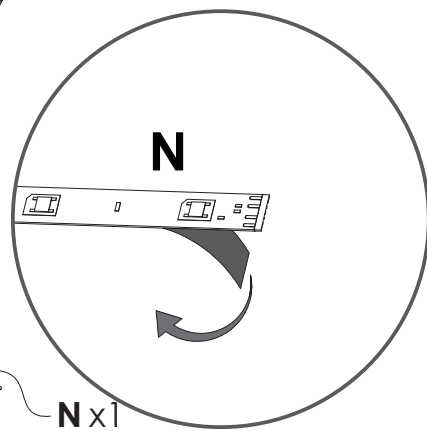
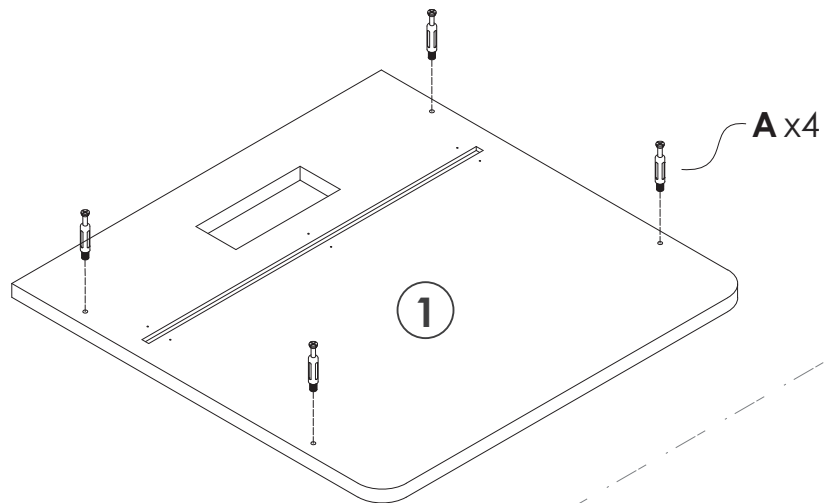

# 14

**B** x4pcs



M15\*11mm

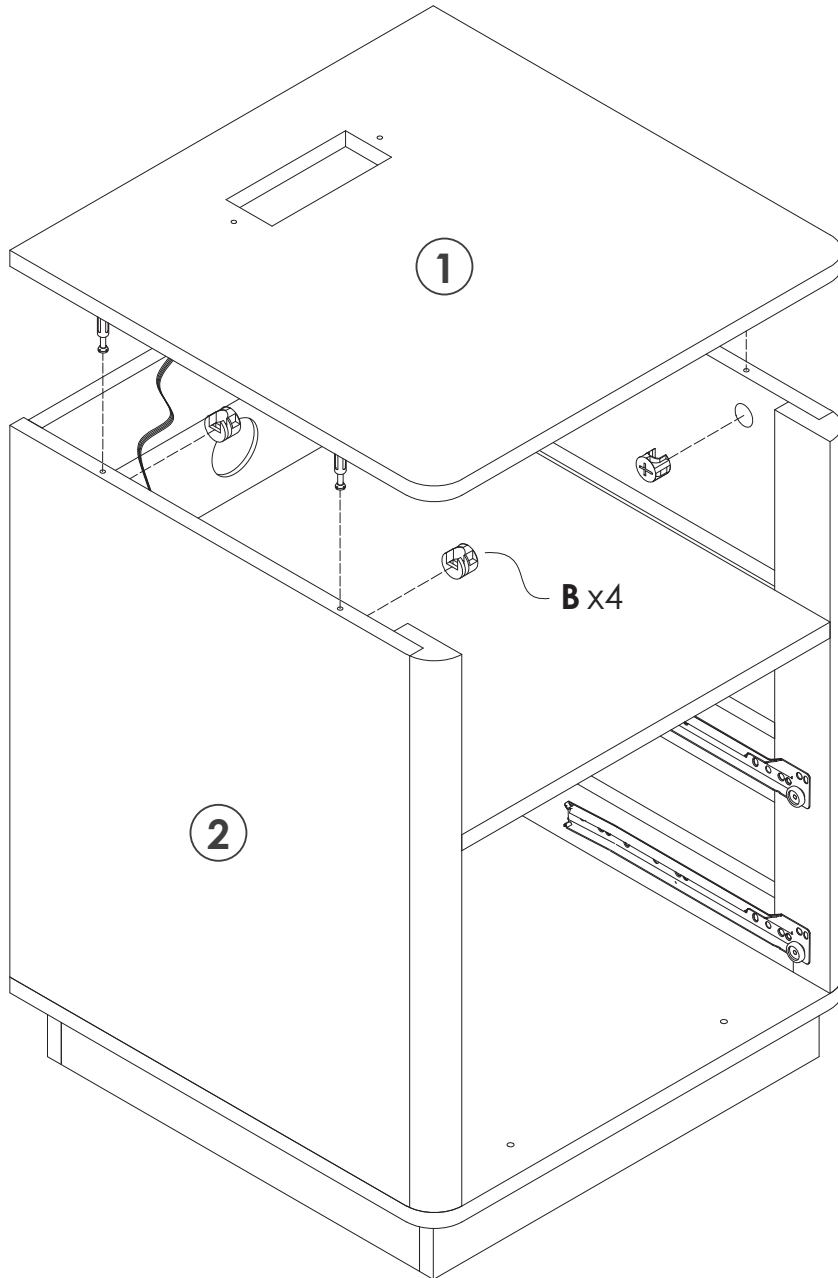

# 15

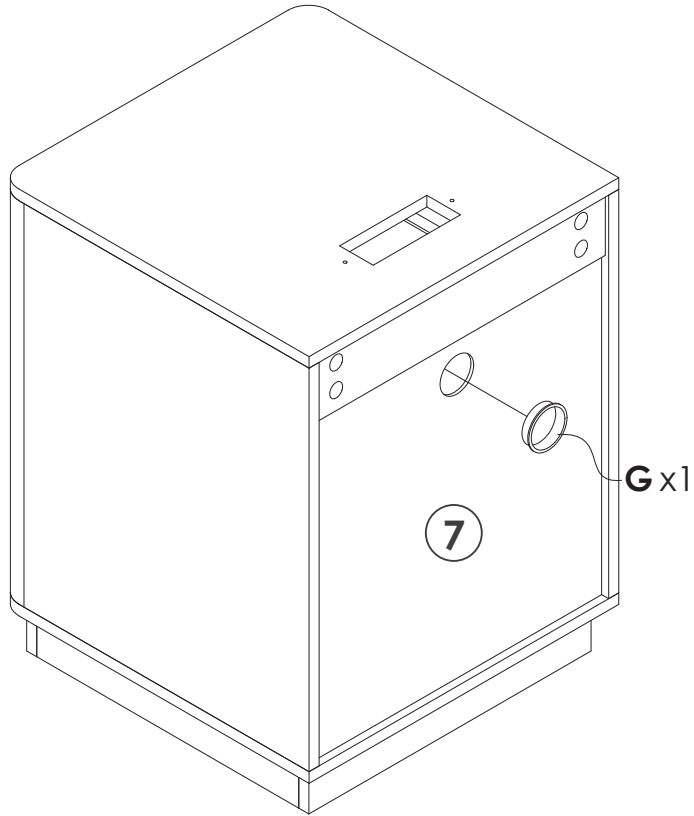
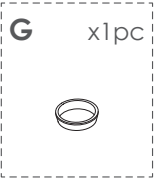

# 16

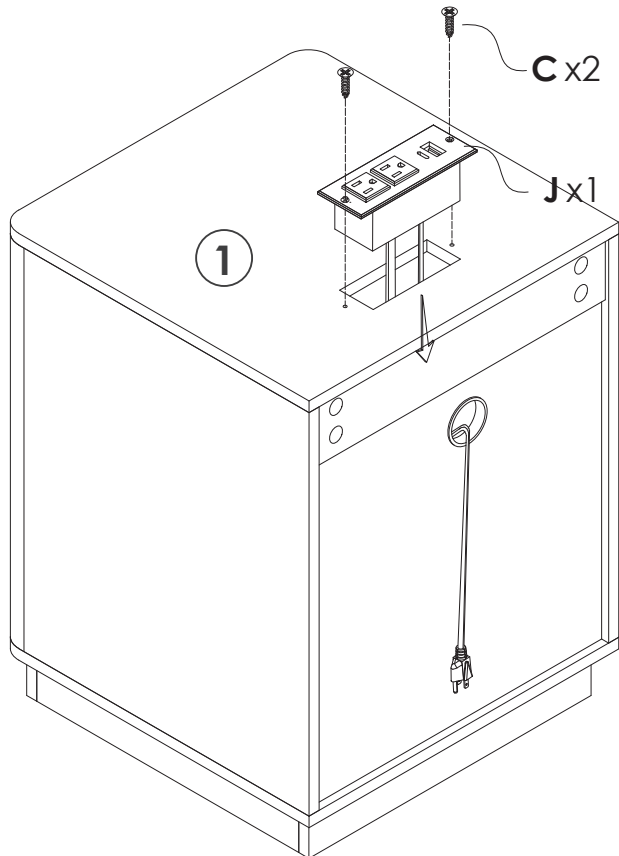
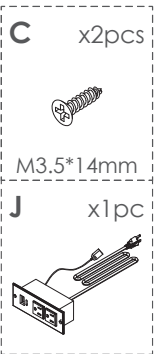

# 17

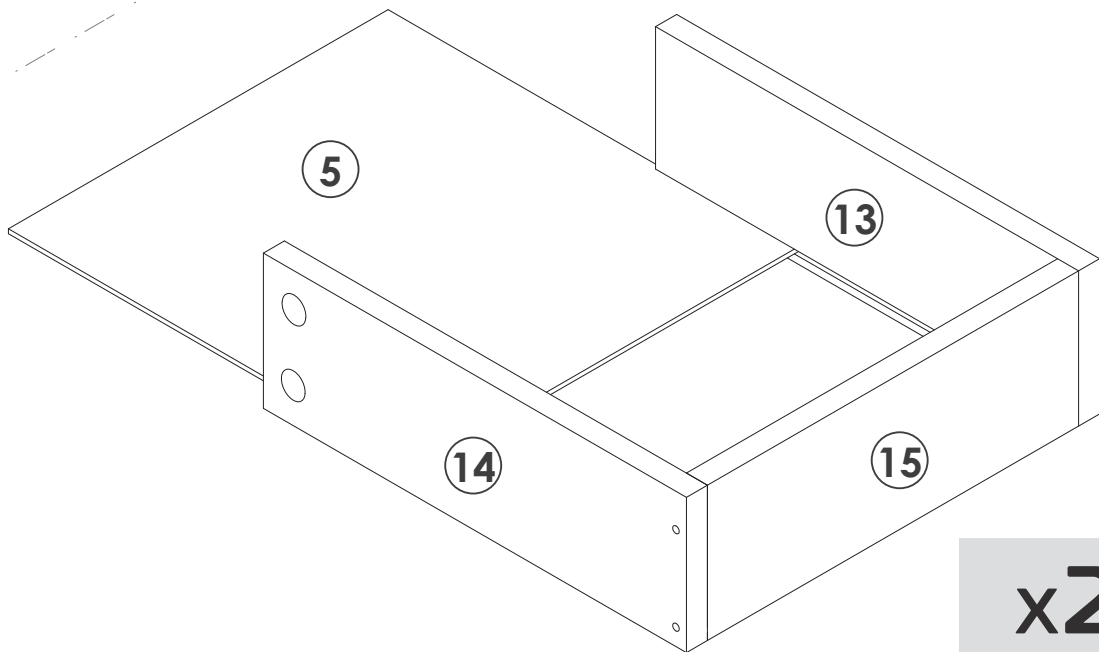
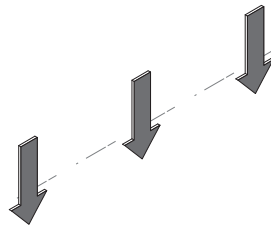
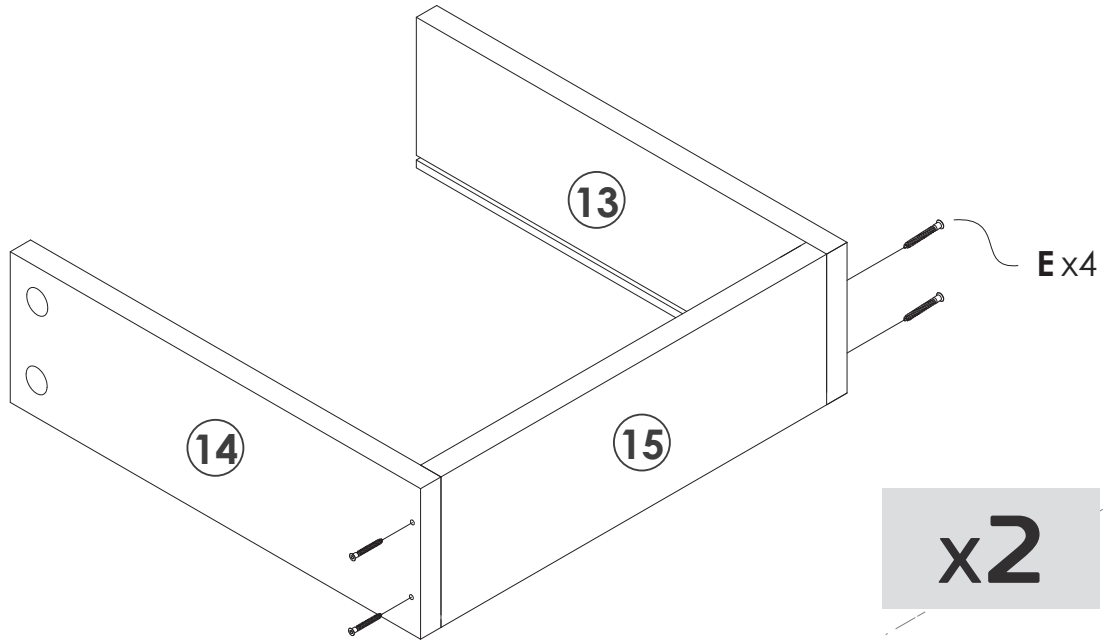
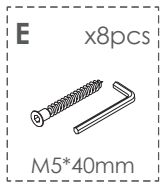

# 18

**R** x8pcs



M6\*40mm

**H** x2pcs



**F** x4pcs



M3\*12mm

**B** x8pcs



M15\*11mm

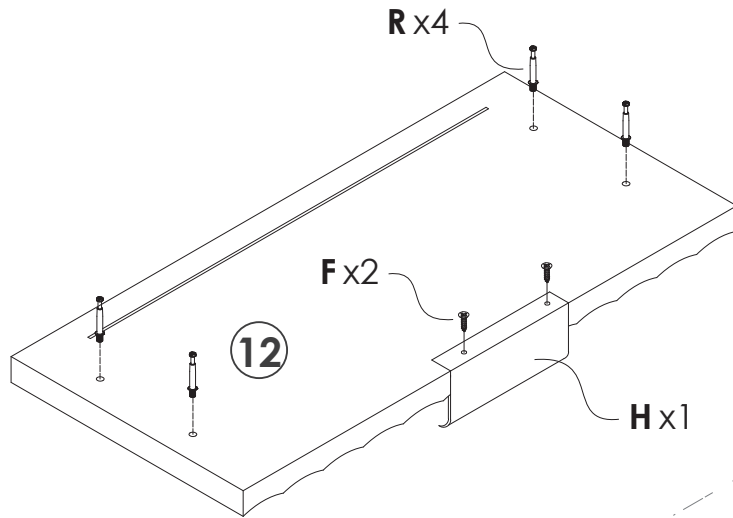

x2

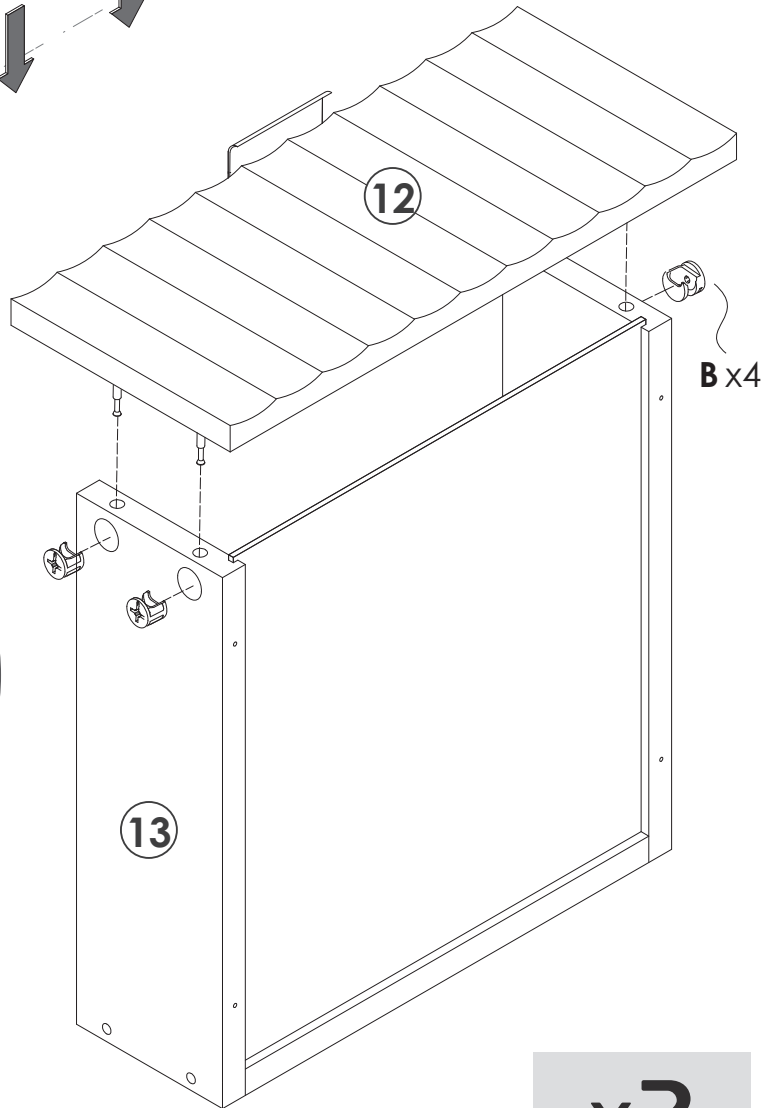
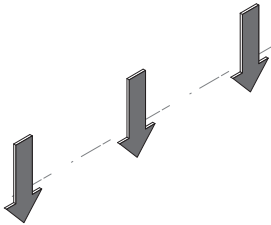

x2

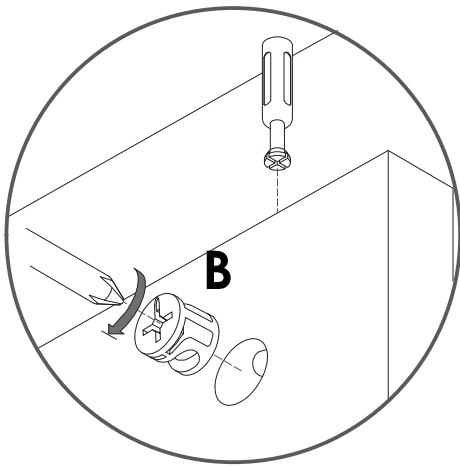

# 19

**F** x8pcs



M3\*12mm

**M** x2pcs

**DL DR**

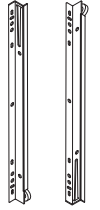

12 inches

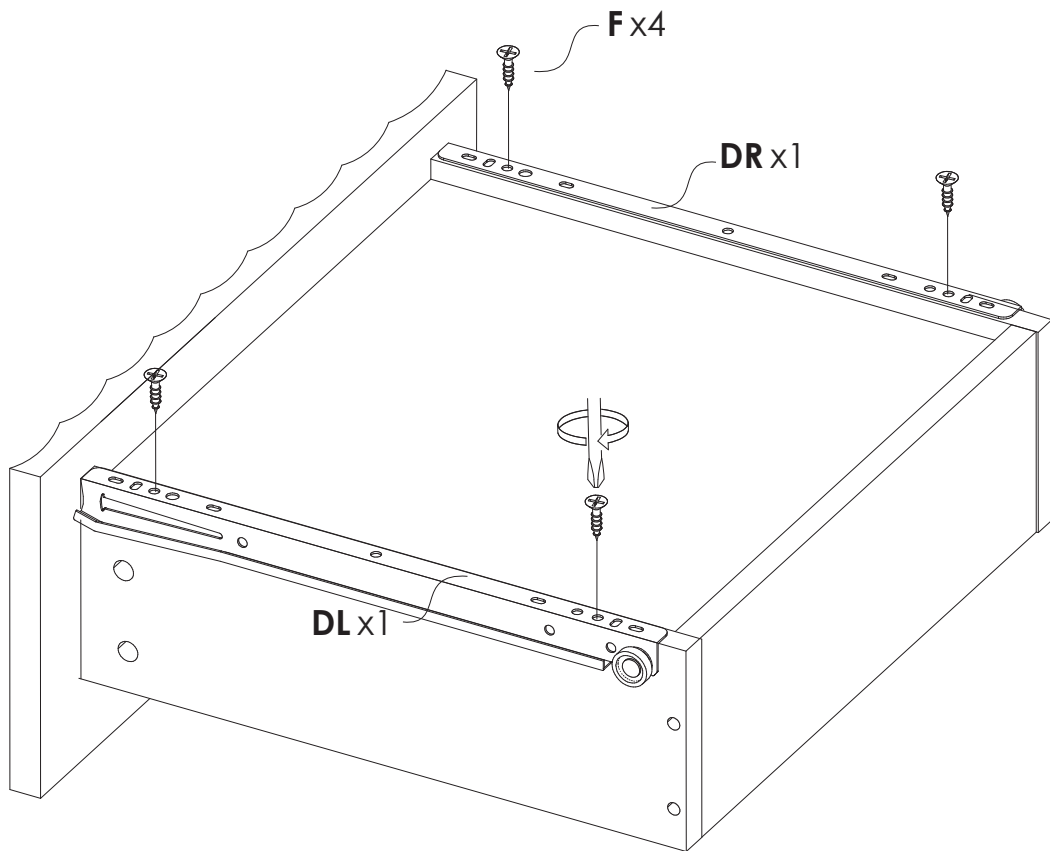

**x2**

# 20

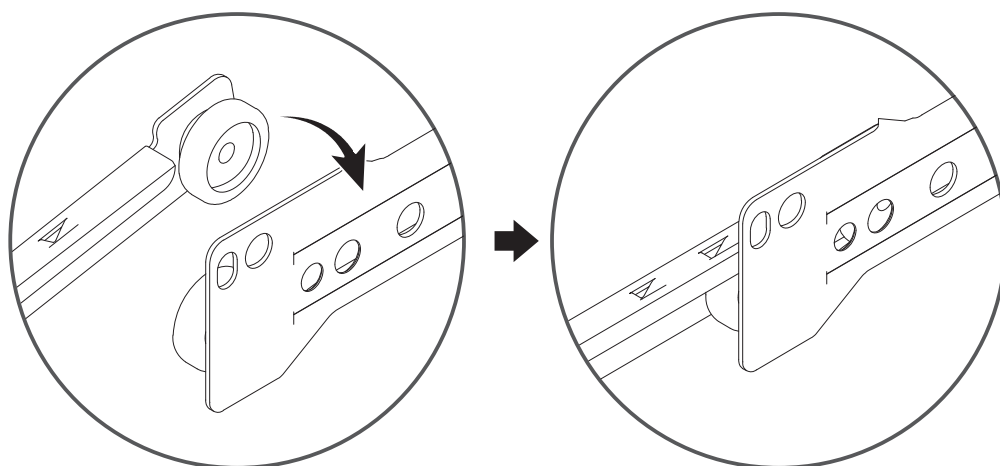
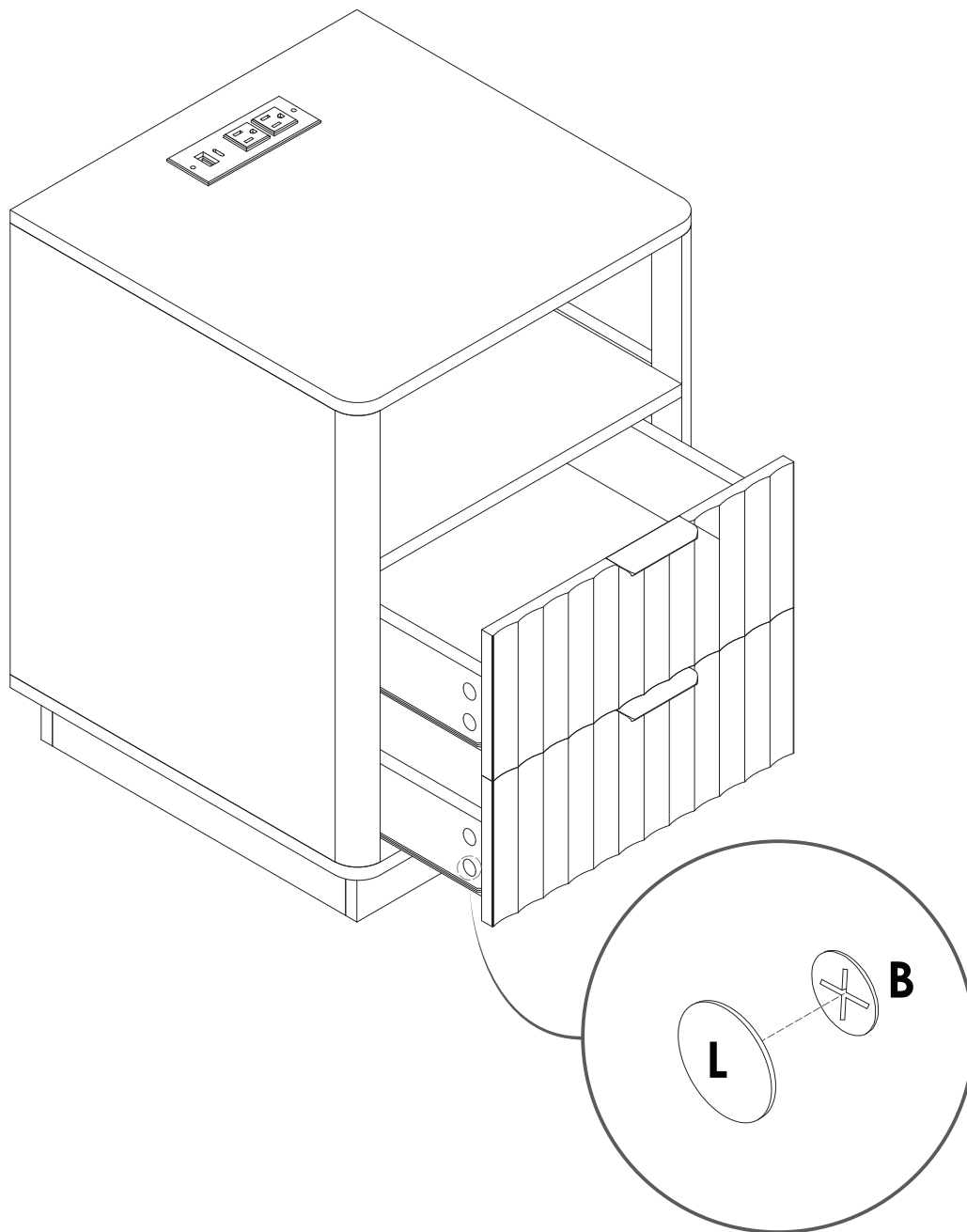
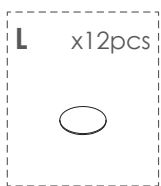

# 21

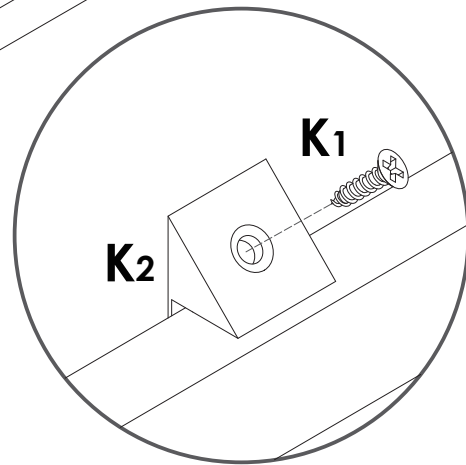
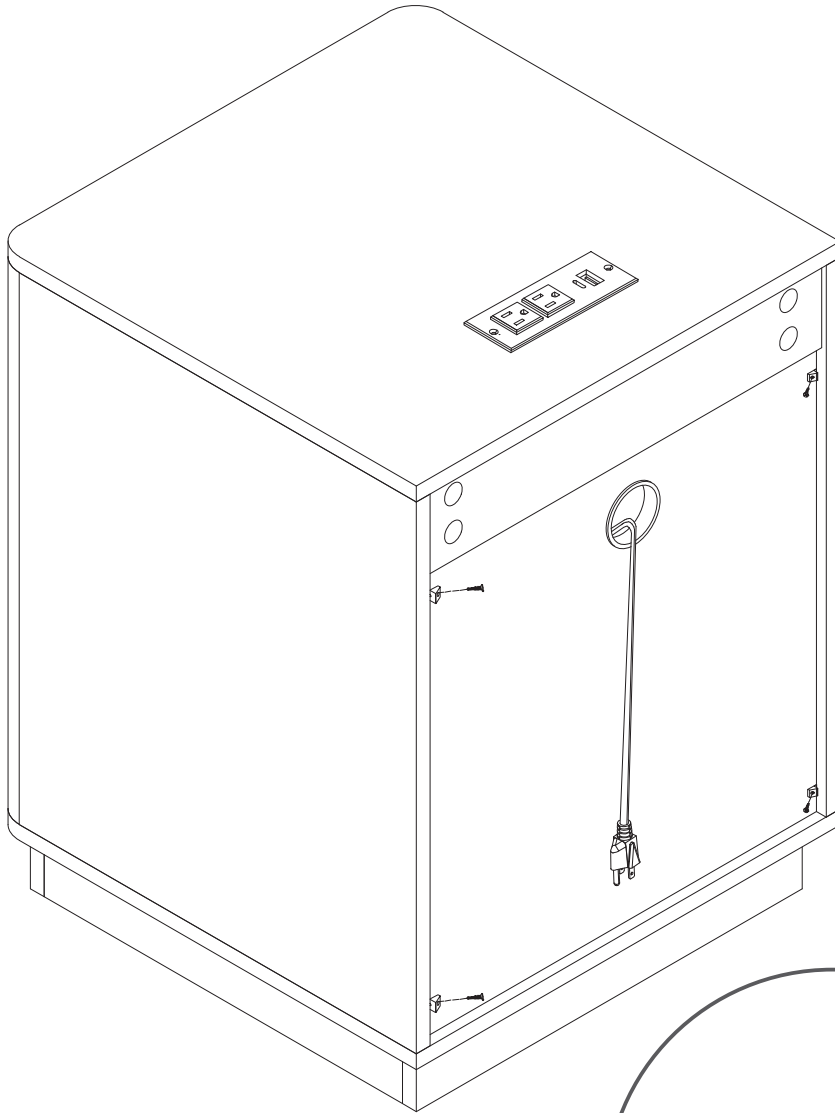
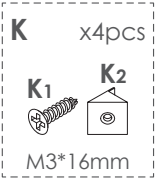

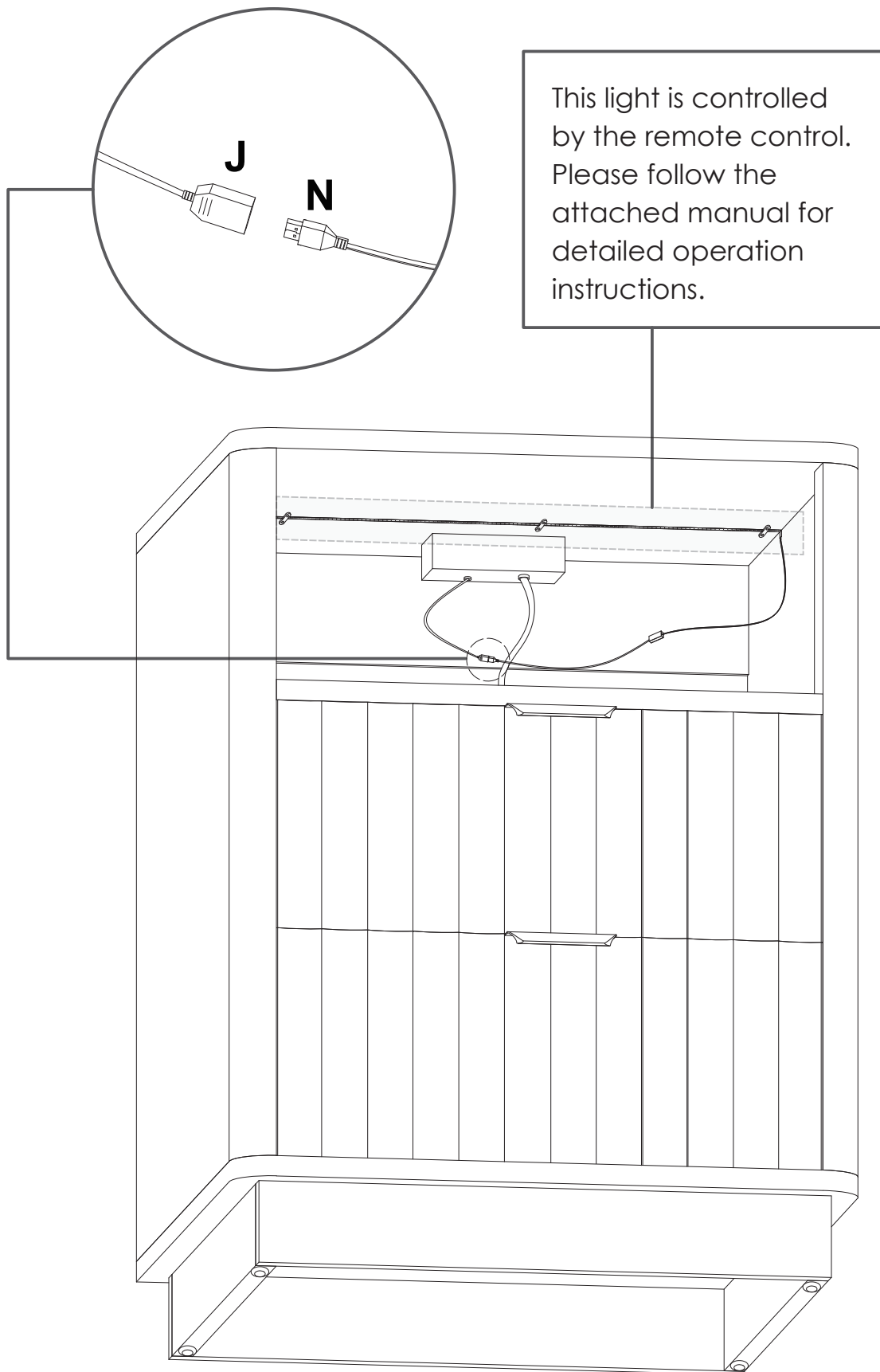

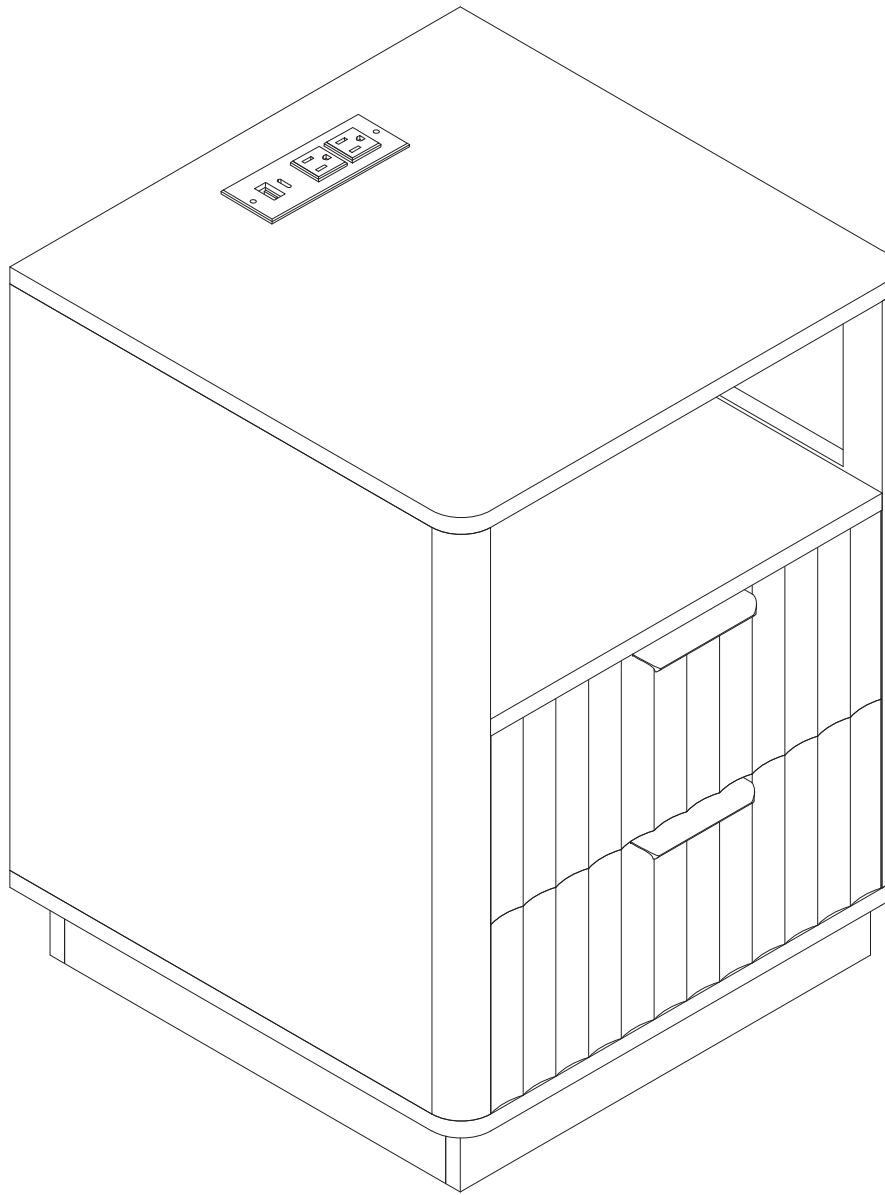

---

## WARRANTY

We provide an **18-month** warranty on the product starting from the date of the original purchase. If the product has any manufacturing defect, please contact us through email with details about the problem. We will send you further information about the return or exchange.

## **! WARNING**

**INGESTION HAZARD:** This product contains a button cell or coin battery. **DEATH** or serious injury can occur if ingested.

A swallowed button cell or coin battery can cause **Internal Chemical Burns** in as little as **2 hours**.

**KEEP** new and used batteries **OUT OF REACH of CHILDREN**

**Seek immediate medical attention** if a battery is suspected to be swallowed or inserted inside any part of the body.



- Remove and immediately recycle or dispose of used batteries according to local regulations and keep away from children. Do NOT dispose of batteries in household trash or incinerate.
- Even used batteries may cause severe injury or death.
- Call a local poison control center for treatment information.
- This product contains a CR2025,DC3V coin battery. A coin battery can cause serious internal chemical burns if swallowed.
- Non-rechargeable batteries are not to be recharged.
- Do not force discharge, recharge, disassemble, heat above 132°F (60°C) or incinerate. Doing so may result in injury due to venting, leakage or explosion resulting in chemical burns.
- Ensure the batteries are installed correctly according to polarity (+ and -).
- Do not mix old and new batteries, different brands or types of batteries, such as alkaline, carbon-zinc, or rechargeable batteries.
- Remove and immediately recycle or dispose of batteries from equipment not used for an extended period of time according to local regulations.
- Always completely secure the battery compartment. If the battery compartment does not close securely, stop using the product, remove the batteries, and keep them away from children.

**This device complies with Part 15 of the FCC Rules. Operation is subject to the following two conditions:**

(1) This device may not cause harmful interference, and (2) this device must accept any interference received, including interference that may cause undesired operation.

**Caution:** changes or modifications not expressly approved by the party responsible for compliance could void the user's authority to operate the equipment.

**NOTE:** This equipment has been tested and found to comply with the limits for a Class B digital device, pursuant to Part 15 of the FCC Rules. These limits are designed to provide reasonable protection against harmful interference in a residential installation. This equipment generates, uses and can radiate radio frequency energy and, if not installed and used in accordance with the instructions, may cause harmful interference to radio communications. However, there is no guarantee that interference will not occur in a particular installation. If this equipment does cause harmful interference to radio or television reception, which can be determined by turning the equipment off and on, the user is encouraged to try to correct the interference by one or more of the following measures:

- Reorient or relocate the receiving antenna.
- Increase the separation between the equipment and receiver.
- Connect the equipment into an outlet on a circuit different from that to which the receiver is connected.
- Consult the dealer or an experienced radio/TV technician for help.