



Outdoor
Living Today

ASSEMBLY MANUAL

12x16 Sunshed Garden Shed

Stock Code:

SSGS1216-AK-CEDAR

SSGS1216-AK-METAL

SSGS1216-AK-PLY

Version #1.6

Oct 28, 2025



CONTACT

ADDRESS

9393 287th Street,
Maple Ridge, British Columbia,
Canada V2W 1L1

PHONE & FAX

Toll Free: 1-888-658-1658

Fax:

ONLINE

Email: olmsupport@outdoorlivingtoday.com

Web: www.outdoorlivingtoday.com

What You Need to Know

Thank you for purchasing a 12x16 Sunshed.

Please take the time to identify all the parts prior to assembly.

IMPORTANT INFORMATION

It is the sole responsibility of the customer to check with your local municipal or county by-laws before ordering this product to confirm it complies with building codes in your area.

If the product is elevated, any structural and building code requirements are solely the customer's responsibility, and should be abided by.

Snow load ratings vary by geographical location. If heavy or wet snowfall occurs, it is advisable to sweep snow off roof frequently. In areas with high or gusty wind conditions, it is advisable to install the structure securely to the ground.

Have a regular maintenance plan to ensure screws, doors, windows and parts are tightly affixed.

All structures purchased from Outdoor Living Today are covered for a period of one year for defects in manufacturing and workmanship. Costs incurred for customer installations are not included.

Failure to use supplied parts included in this kit could result in poor product performance and may void your warranty. Please contact Outdoor Living Today's Customer Toll Free Line if you plan to deviate from our written instructions.

Warranty

In the event of a missing or broken piece, please contact Outdoor Living Today Customer Support at olmsupport@outdoorlivingtoday.com within 30 days of the delivery of your purchase. It is our commitment to you to courier replacement parts, free of charge, within 10 business days of this notification. Replacement parts will not be provided free of charge after the 30 day grace period.

Customer agrees to hold Outdoor Living Today and any Authorized Dealers free of any liability for improper installation, maintenance and repair.

What to do Before my Shed Arrives?



Become familiar with this assembly manual and determine if you can complete the project yourself or will require a professional contractor.



One helper is recommended to assist in constructing your shed. It generally takes two people two days to assemble a shed. If you're hiring a contractor, their rate should be in line with that duration of work.



Clear the construction area and ensure a clear pathway for delivery when the freight company arrives. Remove all debris: roots, grass, rocks, etc.



Excavate the site. Contact your local utilities company to ensure there are no gas or electric lines buried in the area before digging.



Decide on the type of foundation you will be using: Concrete slab, or 4-6 inches of crushed gravel with paver stones or 4x4 stringers.

You can find the footprint for your shed on Page 3 of your Assembly Manual.



If doing the assembly yourself, have all the necessary tools ready to go and in working condition. A list of required tools can be found after the parts list.

Foundation Types for 12x16 Garden Shed

1.

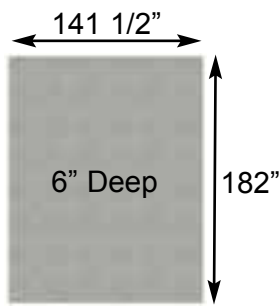

Concrete Foundation

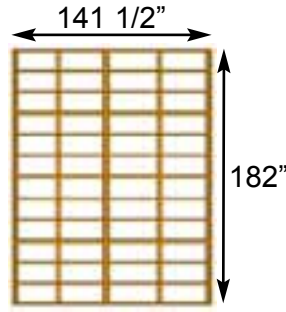

Floor Frame



Completed Foundation

Concrete Slab Foundation:

- Slab must be at least the same size as assembled floor frame (141 1/2" x 182") or larger.
- 6" Deep foundation.
- 3.4 Cubic Yards of concrete required.
- A concrete slab will have the longest durability out of your foundation options.

Once level, a concrete slab is the easiest surface to build on.

2.

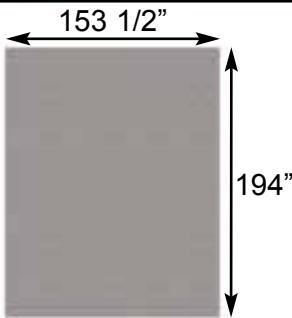

Gravel Foundation

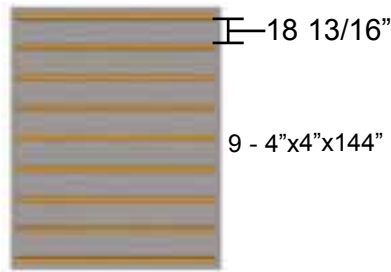

Gravel Foundation with treated stringers



Completed Foundation

Gravel with 4x4 Pressure Treated Stringers:

- Excavate at least 6" deep, and 6" wider than floor frame on each side.
- 3.9 Cubic Yards of gravel required, approximately 36 wheelbarrows.
- 9 - 4x4 Pressure Treated Stringers 12' long required.
- Evenly spaced, with one at each end of floor frame.

Saves money on materials, easy to level and work with.

3.

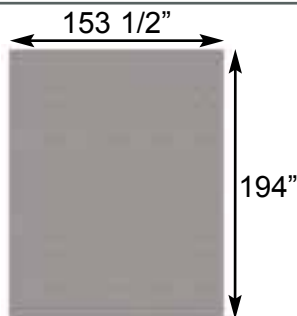

Gravel Foundation

45 Patio Stones



Gravel Foundation with Patio Pavers

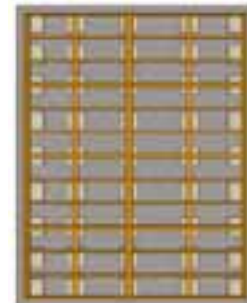

Completed Foundation

Gravel with Patio Paver Stones:

- Excavate at least 6" deep, and 6" wider than floor frame on each side.
- 3.9 Cubic Yards of gravel required, approximately 36 wheelbarrows.
- 45 patio pavers (8" x 8" or larger).
- Center patio paver stones underneath floor runners and underneath seams in floor joists.

Patio paver stones are widely available from most landscape stores.



















Thank you for purchasing our 12x16 SunShed.

Please take the time to identify all the parts prior to assembly.





Parts List	Steps	D. Roof Section - METAL	Steps
A. Floor Section Floors 4 - 45 1/2" x 75" - Floor Joist Frames - Large 4 - 45 1/2" x 66 1/2" - Floor Joist Frames - Small 8 - 1 1/2" x 3 1/2" x 72" - Floor Joists Large - Unattached 8 - 1 1/2" x 3 1/2" x 63 1/2" - Floor Joists Small - Unattached 2 - 1 1/2" x 5 1/2" x 56" - Wide Floor Runner 1 - 1 1/2" x 5 1/2" x 70" - Wide Floor Runner 4 - 1 1/2" x 3 1/2" x 38" - Floor Runners 8 - 1 1/2" x 3 1/2" x 72" - Floor Runners 4 - 5/8" x 45 1/2" x 75" - Floor Plywood Large 4 - 5/8" x 45 1/2" x 66 1/2" - Floor Plywood Small"	A1 - A11	16 - 3/4" x 3 1/2" x 48" - Outside Roof Battens 16 - 3/4" x 3 1/2" x 45 1/2" - Inside Roof Battens 8 - 3/4" x 1 1/2" x 15 3/4" - Batten Spacers Long 4 - 3/4" x 1 1/2" x 13 1/2" - Batten Spacers Short 6 - 86" long - Metal Roof Panels Long 6 - 41" long - Metal Roof Panels Short Several - Foam Enclosures for Metal Roof 4 - 60" long - Metal Ridge Caps	D1 - D17
B. Wall Section Main Wall Panels 4 - 45 1/2" x 75" - Solid Wall Panels 1 - 45 1/2" x 75" - Solid Wall Panel With Extra Vertical Studs 5 - 1 1/2" x 2 1/2" x 45 1/2" - Bottom Wall Plates 4 - 45 1/2" x 75" - Window Wall Panels 4 - 45 1/2" x 75" - Double Window Walls 1 - 12" x 73" - Narrow Wall Panel Door Jamb & Headers 1 - 1 1/2" x 3 1/2" x 73" - Vertical Door Jamb 1 - 2" x 3" x 45 1/2" - Door Header Top Plates, Extenders & Gables 4 - 1 1/2" x 2 1/2" x 70 3/4" - Front & Rear Riser Plates 4 - 1 1/2" x 2 1/2" x 88 1/2" - Side Riser Plates 4 - 3/4" x 2 1/2" x 45" - Front & Rear Top Plates (angle cut ends) 2 - 3/4" x 2 1/2" x 51 1/2" - Front & Rear Top Plates (straight cut ends) 2 - 3/4" x 2 1/2" x 45 1/2" - Side Top Plates (angle cut edge) 4 - 3/4" x 2 1/2" x 65 3/4" - Side Top Plates (angle cut edge) 4 - Triangular Gable Walls	B1 - B9 B10 - B11 B12 - B18	D. Roof Section - PLYWOOD 2 - 5/8" x 48" x 81 1/2" - Long Left & Right Plywood Panels 2 - 5/8" x 45 1/2" x 81 1/2" - Long Center Plywood Panels 2 - 5/8" x 48" x 37 1/2" - Short Left & Right Plywood Panels 2 - 5/8" x 45 1/2" x 37 1/2" - Short Center Plywood Panels D. Polygal Roof Section - CEDAR / METAL / PLYWOOD 8 - 48" long - Polygal Panels E. Trim / Misc. Section Bottom Skirting 14 - 1/2" x 4 1/2" x 45 1/4" - Bottom Skirting Filler & Outer Trim 4 - 7/8" x 2 1/2" x 75" - Filler Trims 10 - 1/2" x 2 1/2" x 80" - Side Trims 4 - 1/2" x 5 1/2" x 82" - Wide Corner Trims 2 - 1/2" x 2 1/2" x 78 1/2" - Rear Wall Trims 1 - 1/2" x 2 1/2" x 78 1/2" - Narrow Door Trim 2 - 1/2" x 3 1/2" x 85" - Door Trims 1 - 1/2" x 2 1/2" x 8" - Horizontal Door Trim 1 - 1/2" x 2 1/2" x 32" - Horizontal Door Trim 2 - 1/2" x 4 1/2" x 42" - Horizontal Gable Trims 4 - 1/2" x 4 1/2" x 45 1/4" - Horizontal Gable Trims 2 - 1/2" x 5 1/2" x 44" - Outside Polygal Ridge Caps 3 - 1/2" x 4 1/2" x 44" Center Polygal Ridge Caps 4 - 1/2" x 2 1/2" x 44" Mid Polygal Ridge Caps Facia Trim 2 - 3/4" x 1 1/2" x 36 1/2" - Facia Cleat Short 4 - 3/4" x 1 1/2" x 40" - Facia Cleat Long 4 - 3/4" x 5 1/2" x 81 1/4" - Front and Rear Facia Angled 4 - 3/4" x 5 1/2" x 49 1/2" Side Facia 2 - 3/4" x 5 1/2" x 89 1/4" - Side Facia 2 - 9 1/2" x 7 1/2" - Pentagon Detail Plates 8 - 8" x 5 1/2" Facia Detail Plates Door Section 1 - Dutch Door with Hardware 2 - 1/2" x 2 1/2" x 72" - Interior Vertical Door Stops 1 - 1/2" x 2 1/2" x 36" - Interior Horizontal Door Stop Miscellaneous 4 - Regular Window Inserts 8 - Narrow Window Inserts 4 - Regular Window Trim Pkgs 8 - Narrow Window Trim Pkgs 8 - Flower Box Kits 4 - 16" x 45" - Long Potting Shelves 1 - 16" x 41" Short Potting Shelf 9 - 1 1/2" x 2 1/2" x 38" - Potting Shelf Legs 1 - Extra Lap Siding 1 - Spare Wall Siding 2 - Spare Shingles - use to shim door, etc 3 - Drip Edge - 60"	D1 - D3 E1 E3 - E14 E15 - E20 E21 - E25 E26 - E30
C. Rafter Section Rafter Assembly 3 - 3/4" x 9 1/4" x 91" - Roof Ridge Boards 2 - 3/4" x 9 1/4" x 45 1/2" - Roof Ridge Boards 24 - 1 1/2" x 3 1/2" x 80 7/8" - Roof Rafters (angle cut ends) 4 - 1/2" x 4 1/2" x 91" - Soffits 4 - 3/4" x 80" x 19 3/4" - Triangular Roof Gussets 12 - 3/4" x 3/4" x 48" - Polygal Support Cleats Long 4 - 3/4" x 3/4" x 38" - Polygal Support Cleats Short	C1 - C15		
D. Roof Section - CEDAR 2 - 51" x 83 3/4" - Long Cedar Side Roof Panels (1 Left, 1 Right) 1 - 45 1/2" x 83 3/4" - Long Cedar Center Roof Panel 2 - 51" x 40 1/2" - Short Cedar Side Roof Panels (1 Left, 1 Right) 1 - 45 1/2" x 40 1/2" - Short Cedar Center Roof Panel 21 - Filler Shingles Long 6 - Filler Shingles Short 29 - Cedar Ridge Caps (28 Long, 1 Short)	D1 - D14		
		Note: We recommend you drill a 1/8" pilot hole for each screw to avoid splitting wood. The hole depth should be equal to 3/4 the length of screw.	

Note: Trim and Skirting pieces are graded with the best face being rough sawn.

Hardware Kit (Provided)

2 1/2" Brown Screw  490 pcs	2" Brown Screw  230 pcs	1 1/4" Brown Screw  485 pcs
1" Silver Screw  72 pcs	3/4" Silver Screw  24 pcs	2" Blackheaded Screw  28 pcs
3/4" Blackheaded Screw  20 pcs	1 1/2" Finishing Nail  670 pcs	1 1/2" Shingle Nail  80 Pcs
Square Drive Bit  1 pc	Door Handle  1 pc	Tee Hinge  4 pcs
Single Rafter Bracket  6 pcs	Double Rafter Bracket  4 pcs	Black Drop Latch  1 pc
90° Metal Bracket  8 pcs	Ridge Board Connector  3 pcs	Silver Barrel Bolt  1 pc
Silicon Caulking  2 pcs		





Hardware Kit - CEDAR ROOF (Provided)

2 1/2"  x 20		
1 1/4"  x 32	1 1/2"  x 12	90° Metal Brackets x 8

Hardware Kit - METAL ROOF (Provided)

1 1/4"  x 52		 x 1	
1 1/2"  x 36			Metal Roof Hanger x 3

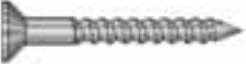
Hardware Kit - PLYWOOD ROOF (Provided)

2 1/2"  x 8		
1 1/4"  x 68	3/4"  x 12	90° Metal Brackets x 8

Tools Required (Not Provided)

Hammer



Screw Gun/Drill



Tape Measure



Wood Clamp



Caulking Gun



Level



Pliers



Ladder



1/8" & 3/8" Drill Bits



Safety Equipment Required (Not Provided)

Safety Glasses



Work Gloves



Advice: Wood has a tendency to split when screwing near the ends of a board. To prevent splitting, it is always recommended to pre-drill pilot holes before screwing into these areas.

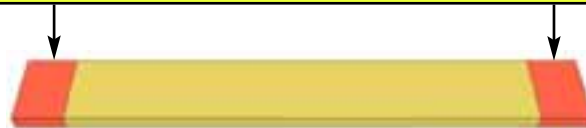

Assembly Manual shows instructions for the Sunshed with Architect Knotty (AK) Siding and three different roof options. Please proceed to correct roof section depending on your selected roof type after rafter installation. The Parts List shows differences in some part sizes between our different types of siding.



Before/During Assembly:

- 1.) Paint each face and edge of your plywood floor with a latex exterior paint.
- 2.) Caulk wall seams if gaps appear.
- 3.) Caulk around window framing (if applicable).
- 4.) Caulk perimeter between floor plywood and bottom wall plate.
- 5.) Caulk channels in lap siding at the top of your door above the trim, just a drop in each channel.
- 6.) Caulk edge of door threshold (if applicable).
- 7.) Optional: Install a Sill Gasket between floor runners and foundation.
- 8.) Optional: Install an 8" strip of roofing paper below Cedar Ridge Caps for Cedar Roof Sheds.

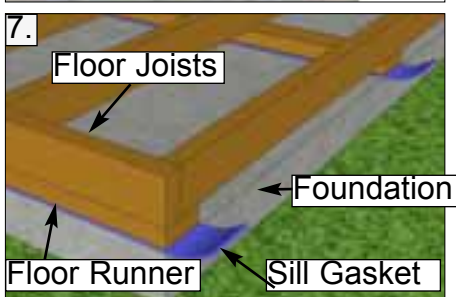
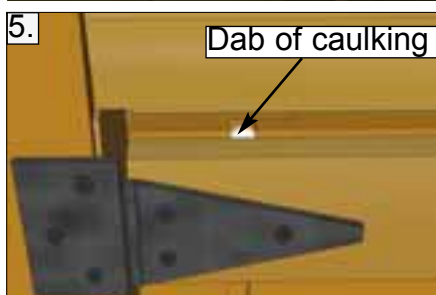
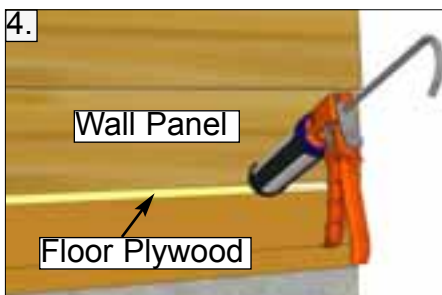
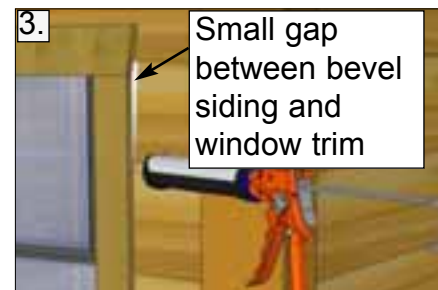
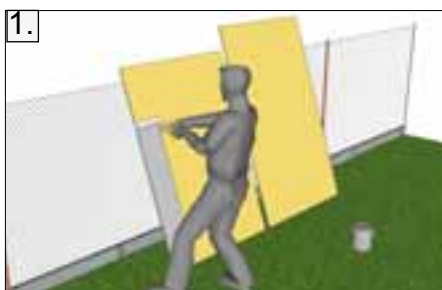

Routine Maintenance:

- Routinely check all fasteners are tight (ex. Door Hinges, Nails)
- Brush off dirt from walls.
- Brush off snow from roof regularly.
- Routinely remove needles and leaves from roof.

Painting/Staining

- Your cedar shed, if left untreated, will weather to a silvery grey colour.
- Painting or staining your structure is highly recommended and will prolong the life of your shed.
- You do not need to wait to paint or stain your shed, the wood in your kit has been dried and can be stained or painted immediately.
- Consult your local paint store for the best paint or stain for cedar.
- Optional: stain the inside of your shed. (Note: this will remove the fresh cedar smell.)

A. Floor Section

Exploded view of all parts necessary to complete Floor Section. Identify all parts prior to starting. Note: Floor Footprint is 182" deep x 141 1/2" wide.

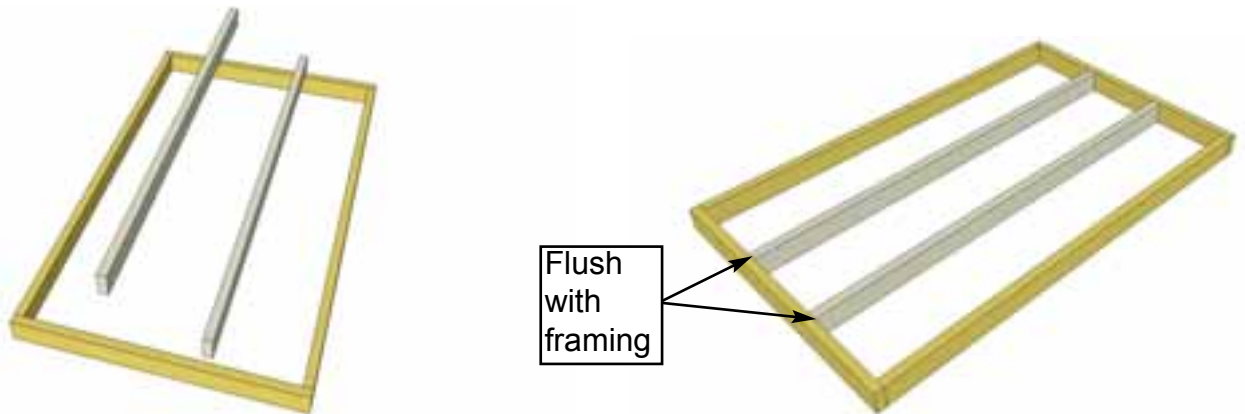
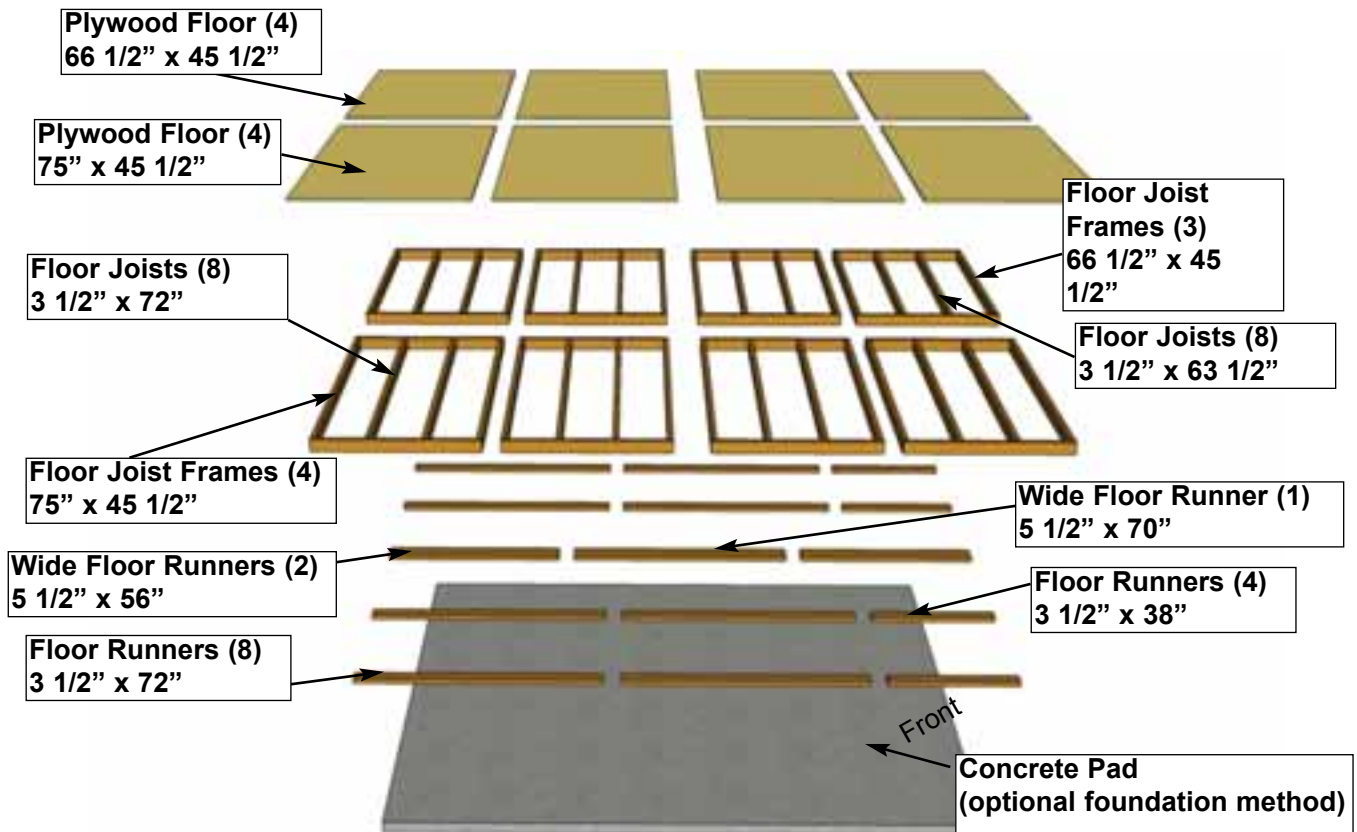

<p>A1. Lay out all Floor Joist Frames and Floor Joists on ground as illustrated above. Position 72" Floor Joists in 75" frames and 63 1/2" Floor Joists in 66 1/2" frames. Position Joists equally in Floor Joist Frame. Position Joist so flush with framing.</p>	<p><u>Parts (Steps A1 - A3)</u> Floor Joists - Large (1 1/2" x 3 1/2" x 72") x 8 Floor Joists - Small (1 1/2" x 3 1/2" x 63 1/2") x 8 Floor Joist Frames - Large (45 1/2" x 75") x 4 Floor Joist Frames - Small (45 1/2" x 66 1/2") x 4</p>	<p><u>Hardware (Steps A1 - A3)</u> S1 - 2 1/2" Screws x 58 total</p>
---	---	---

You can find the Square Drive Bit for the screws in with the Hardware Kit Bag.

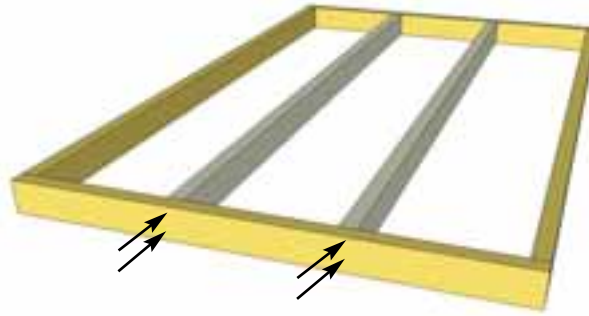

A2. When correctly positioned, attach each Joist with 4 - 2 1/2" screws (2 per end). Complete all Floor Frame and Joist connections. You can find the Square Drive Bit for the screws in with the Hardware Kit Bag.

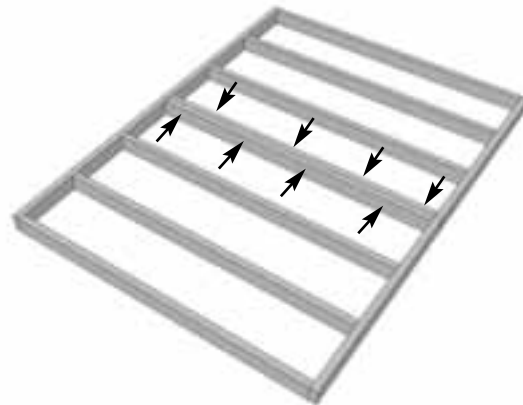

A3. Lay out 75" Floor Frames as shown above. Attach each completed frame to the next with 8 - 2 1/2" screws (24 Total). Once complete assemble 66 1/2" Floor Frames the same way.

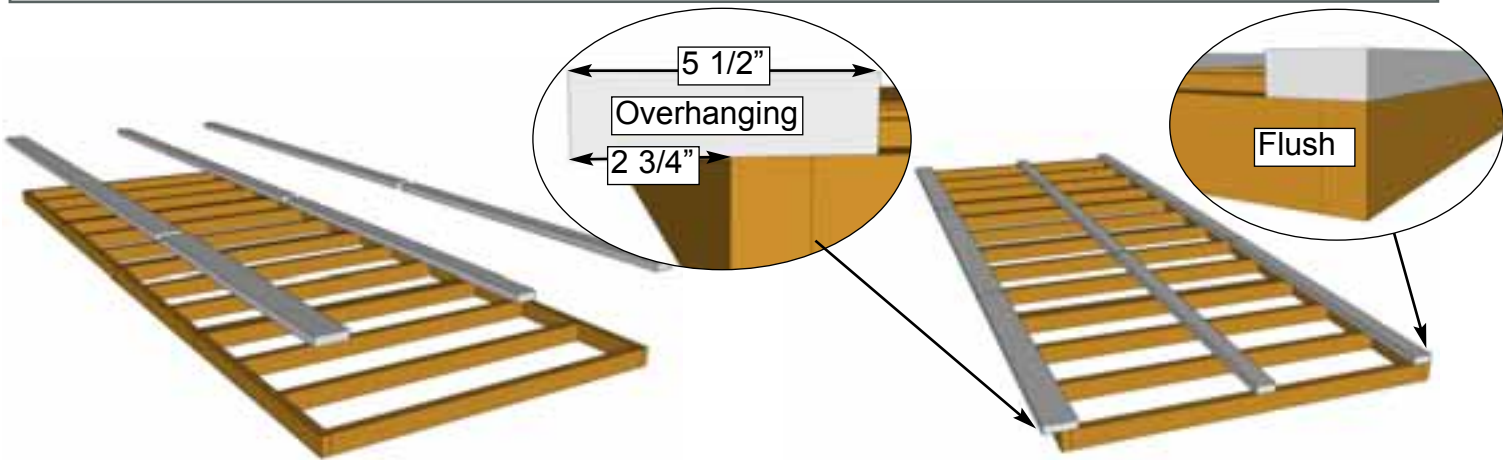

A4. Locate Floor Runners and Wide Floor Runners. Lay out Floor Runners above Completed Floor Frame section as shown above. The 3 1/2" wide Floor Runner should be flush with the edge of the floor frame. 5 1/2" wide Floor Runner should overhang the edge of the floor Frame by 2 3/4". Third set of Floor Runners should be centered on Floor Frame.

Parts (Steps A4 - A9)
Wide Floor Runners (1 1/2" x 5 1/2" x 56") x 2
Wide Floor Runner (1 1/2" x 5 1/2" x 70") x 1
Floor Runners (1 1/2" x 3 1/2" x 38") x 4
Floor Runner (1 1/2" x 3 1/2" x 72") x 8

Hardware (Steps A4 - A9)
S1 - 2 1/2" Screws x 116 total

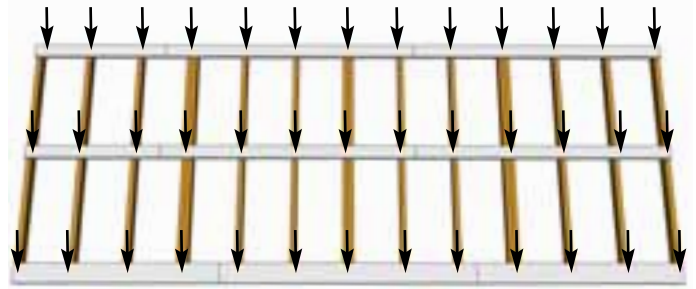
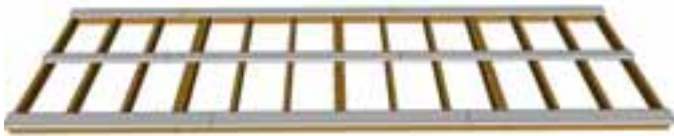

A5. Attach Floor Runners to Floor Frames with 13 - 2 1/2" screws per completed runner length (39 Total). For Wide Floor Runner use 4 screws in the 56" pieces and 5 screws in the 70" piece. For the 3 1/2" Floor Runner use 5 screws for the 72" pieces and 3 screws for the 38" pieces.

Foundations

Note: The floor will be flipped over and floor runners will sit on your foundation. It is important to note that having a level foundation is critical. Choosing a foundation will vary between regions. Typical foundations can be concrete pads or patio stones positioned underneath the floor runners.

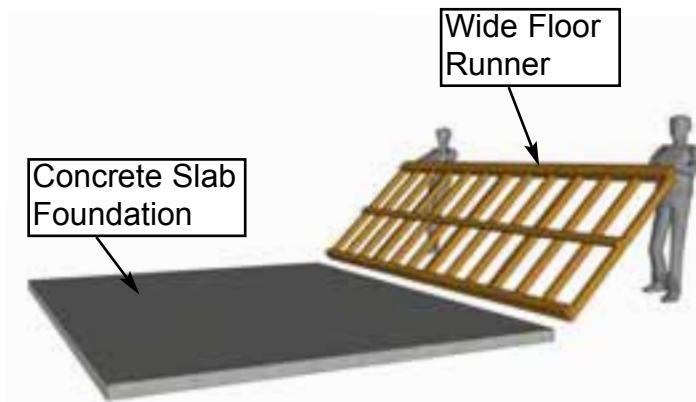

A6. With some helpers, flip the floor section over so it rests on your foundation. **Wide Floor Runner** should rest in the center of your foundation. **Caution:** you will need 2 people to assist you. Be careful when laying floor down not to bend or twist floor. When in place, level floor completely.

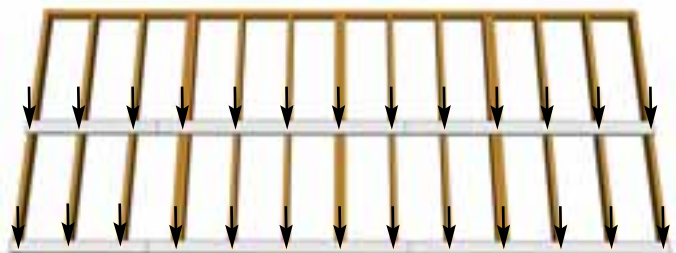

A7. Lay out Remaining Floor Runners on second floor frames (4x 72" Runners and 2x 38" Runners). Attach remaining runners with a total of 26 - 2 1/2" screws as per Step 5.

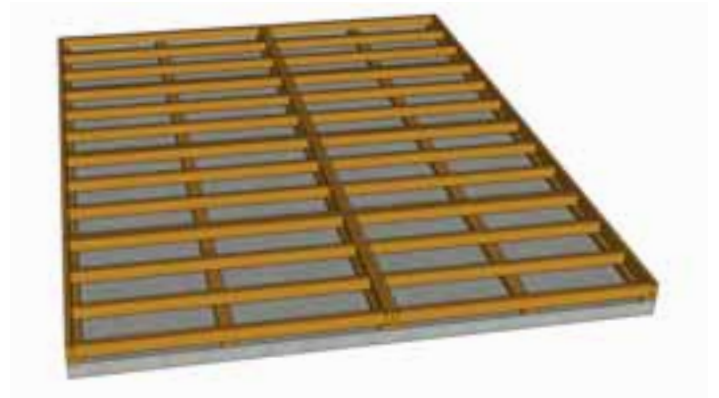
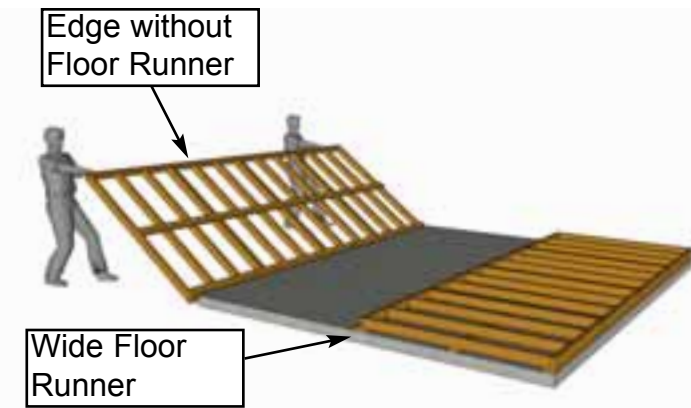

A8. With a helper, flip remaining floor section over onto your foundation. Edge of frame without floor runner should land on wide floor runner.

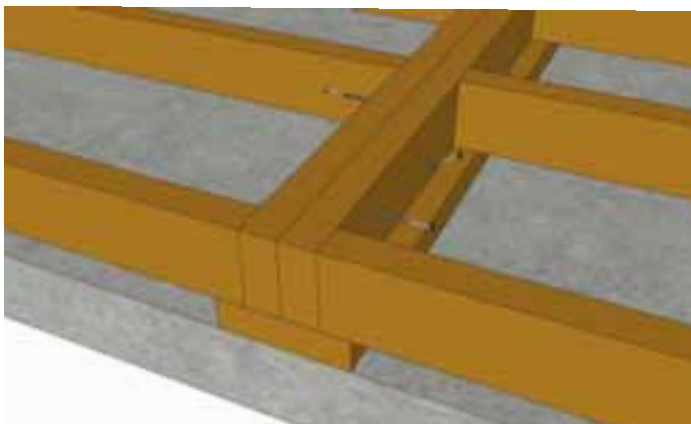

A9. To attach floor sections together attach each 75" Frame to 66 1/2" Frame with 3 - 2 1/2" screws (36 Total). Use 2 screws on both sides to attach horizontally. On the 66 1/2" Frame side toenail one screw into the Wide Floor Runner.

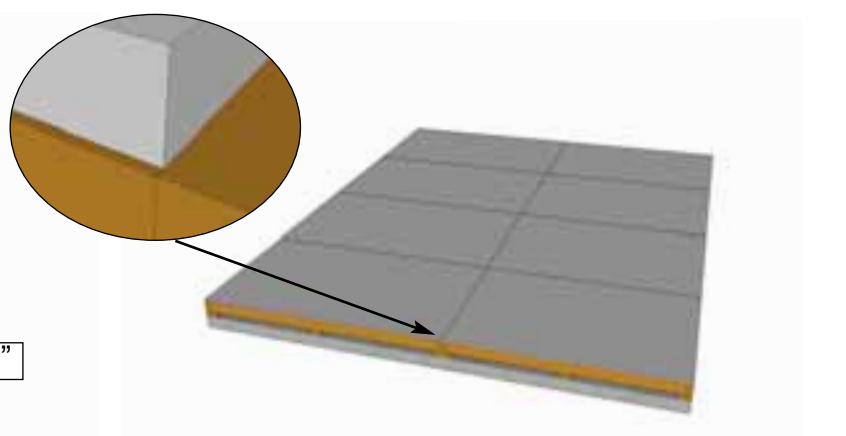
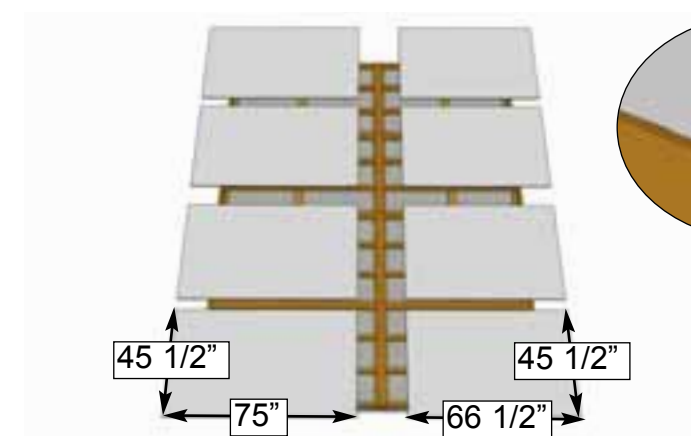

A10. Position Plywood Floor pieces (8) on top of completed Floor Joists. Plywood will sit slightly back from edge of Floor Joist Framing.

Parts (Steps A10 - A11)
Floor Plywood - Large
 (5/8" x 45 1/2" x 75") x 4
Floor Plywood - Small
 (5/8" x 45 1/2" x 66 1/2") x 4

Hardware (Steps A10 - A11)
S2 - 1 1/4" Screws
 x 120 total

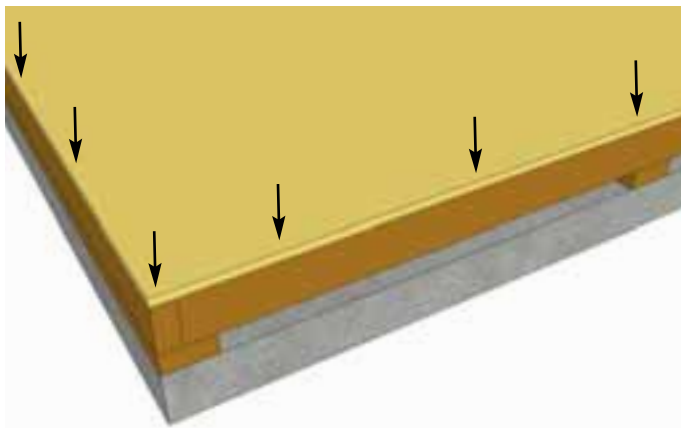

Hint: Use a chalk line to mark location of floor joists to determine screw placement.

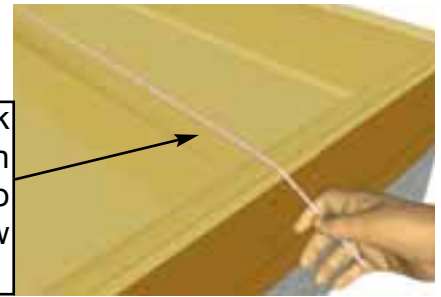

A11. With **Floor Plywood** pieces in position, attach with **1 1/4" screws**. Use screws every 16" (approximately 120 total). The plywood is cut slightly smaller than floor framing. Keep plywood seams tight.

Important: Check to confirm that your floor is level prior to proceeding to the next step of wall assembly.

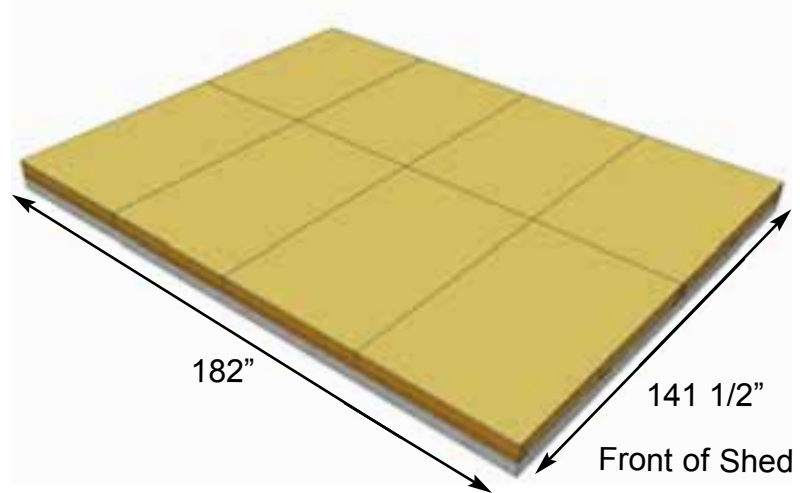

B. Wall Section

Exploded view of all parts necessary to complete the Wall Section.
Identify all parts prior to starting.

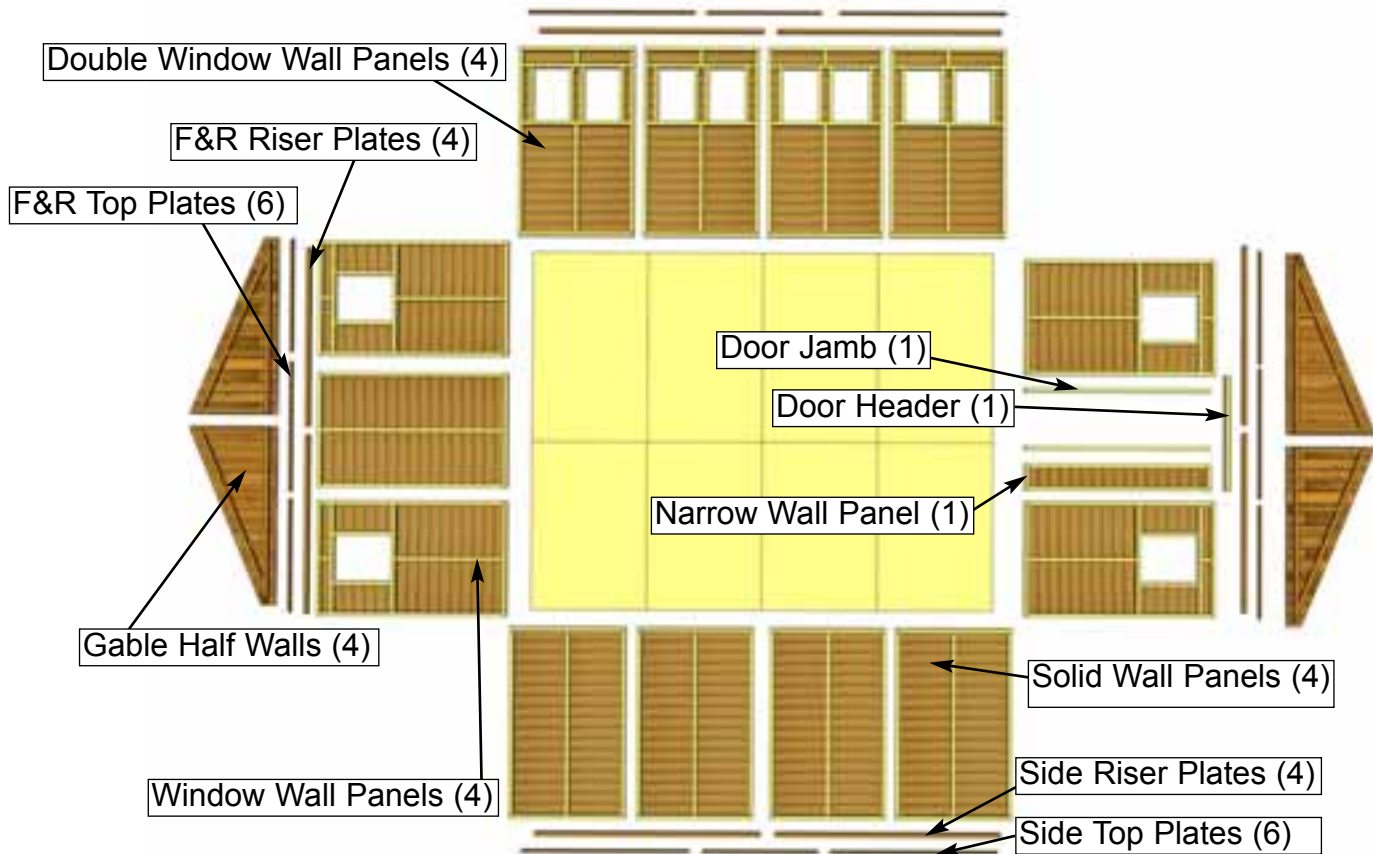

Important:
Pilot hole **ALL** 2x3 Wall Studs with 1/8" drill bit prior to screwing. This will make it much easier to attached together.

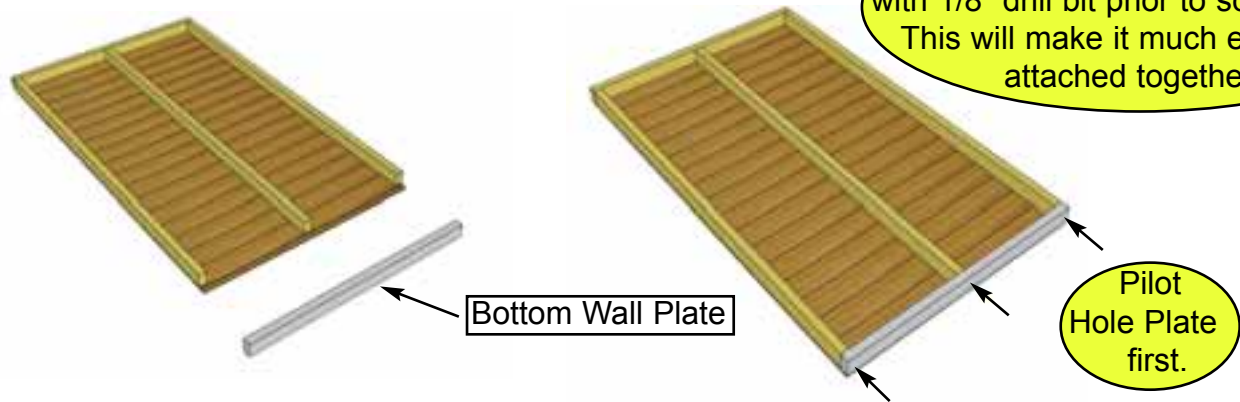

<p>B1. Starting with Solid Wall Panels, carefully lay panel face down. Position and attach Wall Plate to bottom of wall studs of each Wall Panel with 3 - 2 1/2" screws. Position so plates are flush with framing. Note: Bottom Wall Plates may already be attached to some Solid Walls.</p>	<p><u>Parts (Step B1)</u> Solid Wall Panels (45 1/2" x 75") x 4 Bottom Wall Plates (1 1/2" x 2 1/2" x 45 1/2") x 5</p>	<p><u>Hardware (Step B1)</u> 2 1/2" Screws x 15 total</p>
---	--	--

Important: Make sure all walls are aligned in their upright position. If not, water may leak into your shed. Unsure if panel is facing up or down? check siding on window wall panel to match alignment.

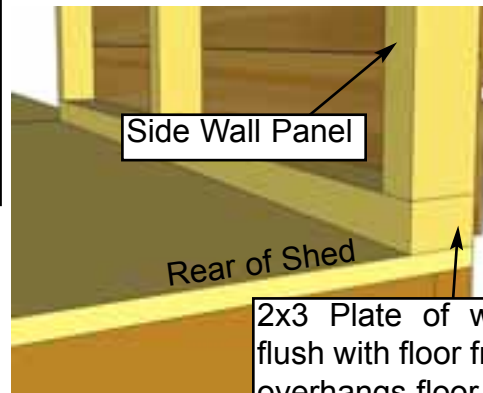

2x3 Plate of wall panel is flush with floor frame. Siding overhangs floor by 3/4".

B2. Starting at Rear Corner, position a **Solid Wall Panel** on top of plywood floor. Make sure panel is facing up. The **Side Wall Panels** will sit flush with floor frame with the front and rear panels sandwiched between them. **Note:** siding will overhang the floor by approx. 3/4".

Parts (Step B2)
Solid Wall Panels
 (45 1/2" x 75") x 4
Window Wall Panels
 (45 1/2" x 75") x 4
Double Window Walls
 (45 1/2" x 75") x 4

Hardware (Step B2)
2 1/2" Screws
 x 39 total

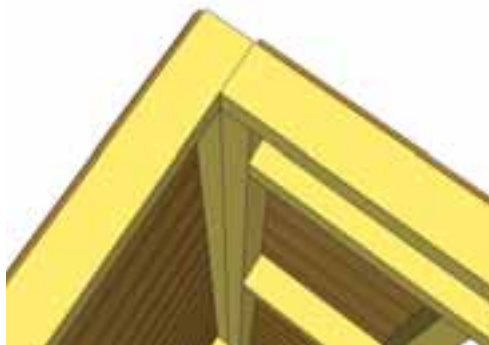

Side Solid Wall



Rear Window Wall

B3. Position rear **Window Wall Panel** into place on plywood floor. Butt both vertical wall studs of side and rear walls together and attach with **3 - 2 1/2" screws**. Screw at the bottom, middle and top of stud to secure properly.

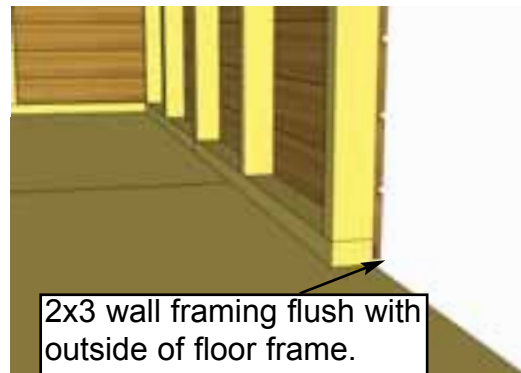

2x3 wall framing flush with outside of floor frame.

B4. With the corner wall attachment complete, position a **Rear Solid Wall Panel With Extra Vertical Studs** so bottom 2x3 wall framing is sitting flush with outside floor frame. Wall siding should overhang floor by approximately 3/4". Attach rear wall panel studs together as per **Step B3**.



Important: Do not attach walls to floor until **Step 26**

B5. Position the final Rear Panel on the floor (**Window Wall Panel**). Position vertical wall studs together and attach as per **Step B3**.

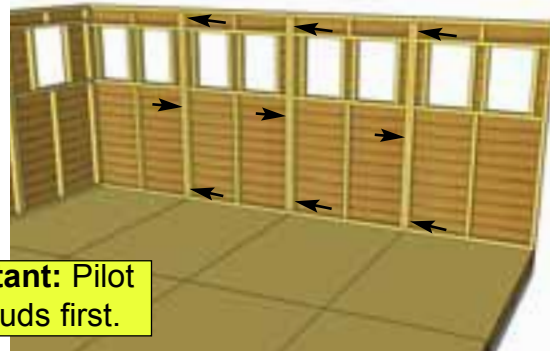
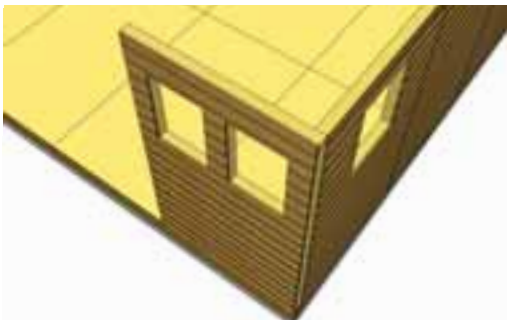

Important: Pilot hole studs first.

B6. Attach a **Double Window Wall Panel** in corner. Attach as per **Step B3**. Start positioning and securing remaining **Double Window Walls**. Attach wall studs together as per **Step B3**.

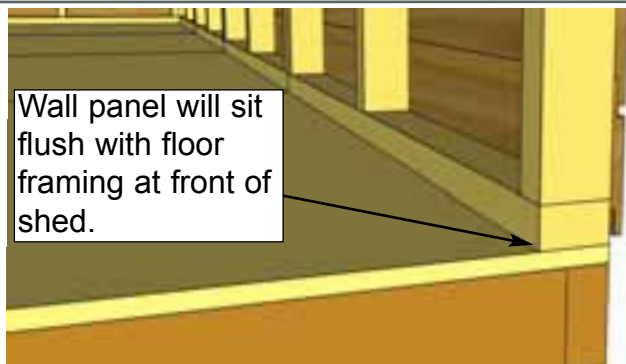

Wall panel will sit flush with floor framing at front of shed.



B7. Complete attachment of left side **Solid Wall Panels**. At the front of the shed, side walls will sit flush with front floor framing.

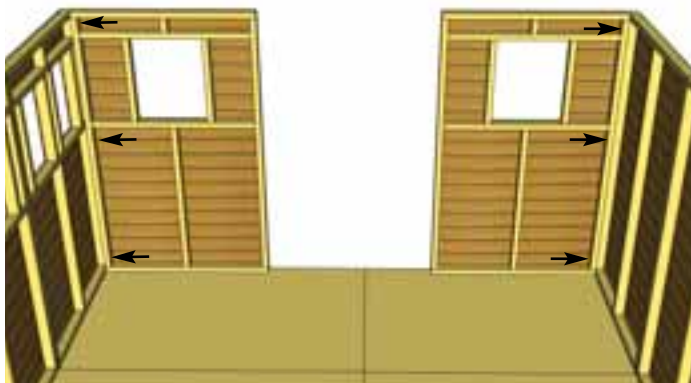

B8. Secure remaining two **Window Walls** to both front corners of shed.

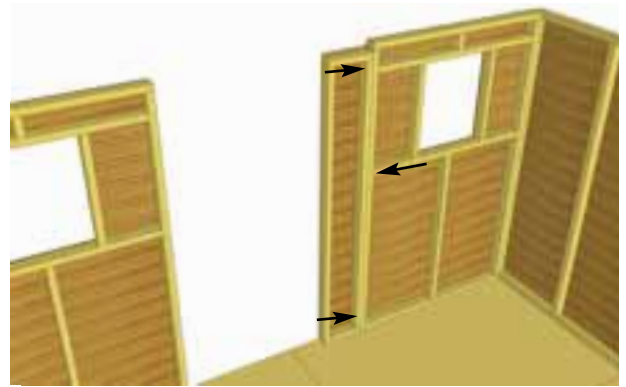

B9. Lineup **Narrow Wall** so flush with each other on the outside. Attach Studs together with 3 - **2 1/2" Screws** as per **Step B3**. **Note:** Narrow Wall is 73" high (9" shorter than other walls).

Parts (Step B9)
Narrow Wall Panel
(12" x 73") x 1

Hardware (Step B9)
2 1/2" Screws
x 3 total

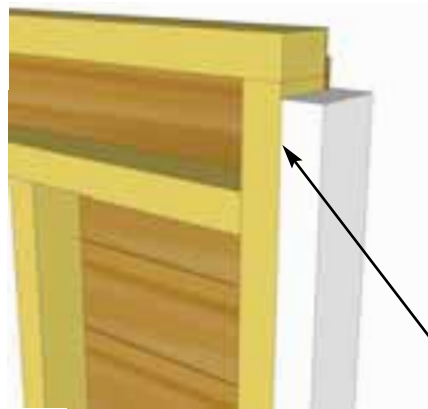
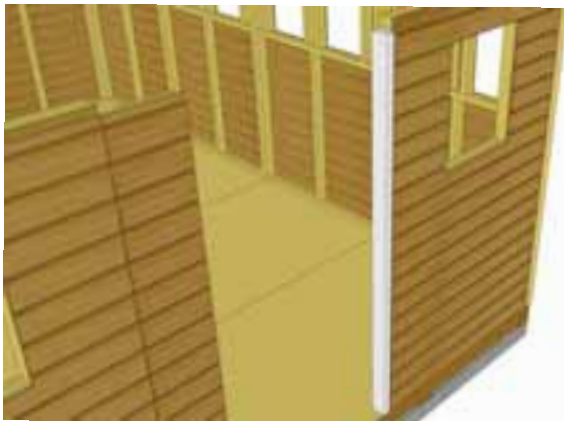

Door Jamb sits flush with wall framing.

B10. Locate **Vertical Door Jamb** and position flush against right wall panel stud. The Jamb is 3 1/2" wide and will sit flush to outside of wall siding. When positioned correctly, secure Jamb using 4 - **2 1/2" Screws**. **Note:** Part size will vary depending on type of siding chosen for shed. See Parts List.

Part (Step B10)
Vertical Door Jamb
(1 1/2" x 3 1/2" x 73") x 1

Hardware (Step B10)
2 1/2" Screws
x 4 total

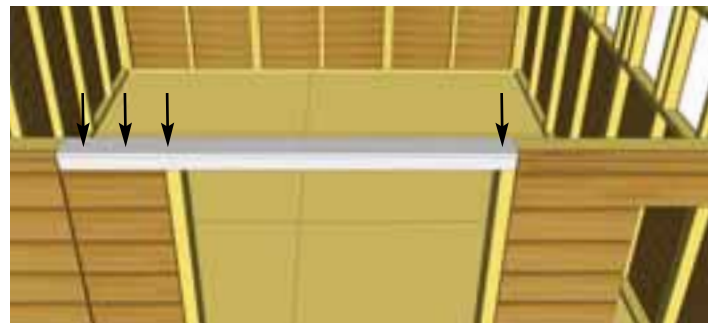

B11. Position and attach **Door Header** to **Door Jamb** and **Narrow Wall Panel** top framing. Header should fit flush with **Door Jamb** and Outside of **Narrow Wall** Siding. Attach with 4 - **2 1/2" Screws**.

Part (Step B11)
Door Header
(2" x 3" x 45 1/2") x 1

Hardware (Step B11)
2 1/2" Screws
x 4 total

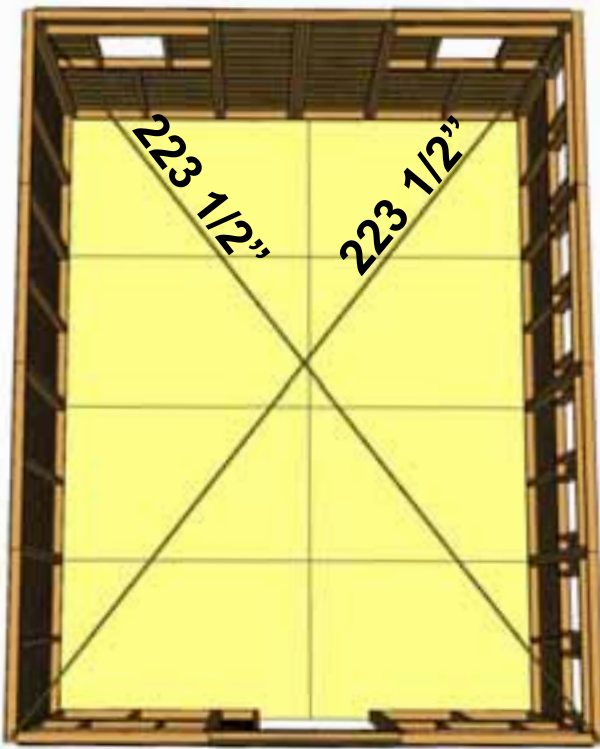

Advice: Prior to fastening walls and installing rafters, take time to confirm your walls are level, square and plumb.

Measure diagonal at top and bottom of walls corner-to-corner. This should be approximately 223 1/2". More importantly, if measurements are not within 1/4", your walls are not square. Adjusting now will make it easier to the roof section later.

Important: If walls are not lining up and appear higher or lower than each other, please check the level of your floor. You may need to make slight adjustments before proceeding.

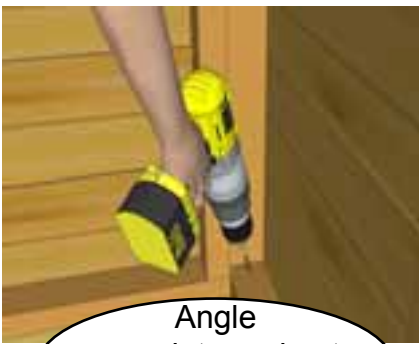

Angle screws into perimeter Floor Joists.

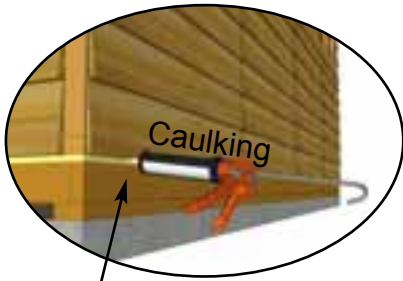

Caulking

Optional: Caulking seams will help prevent moisture from entering your shed. Caulking is included to complete polygal Windows only. Additional Caulking may be required.

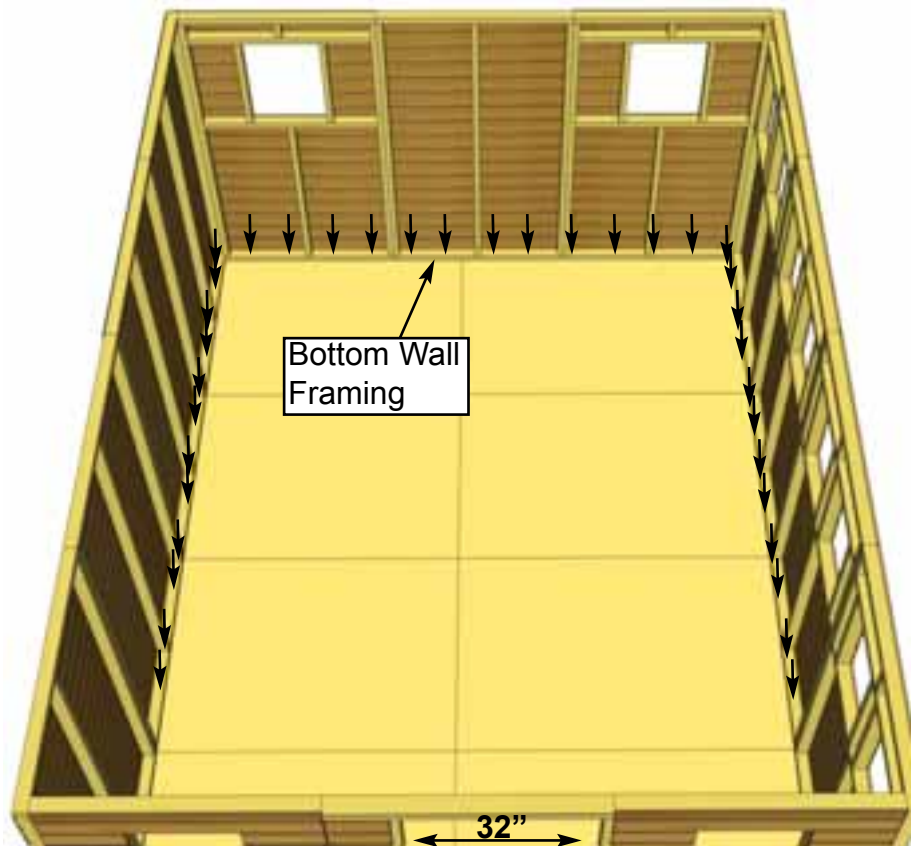

B12. When all walls are attached together, check alignment with the floor. Bottom wall framing should sit flush with outside of floor joists. When positioned correctly, fasten bottom wall plates to floor using 4 - 2 1/2" screws per wall panel (54 total). **Confirm 32" wide door opening at bottom.**

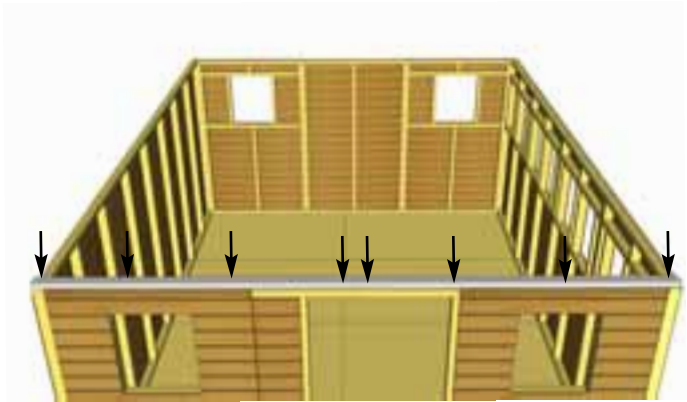
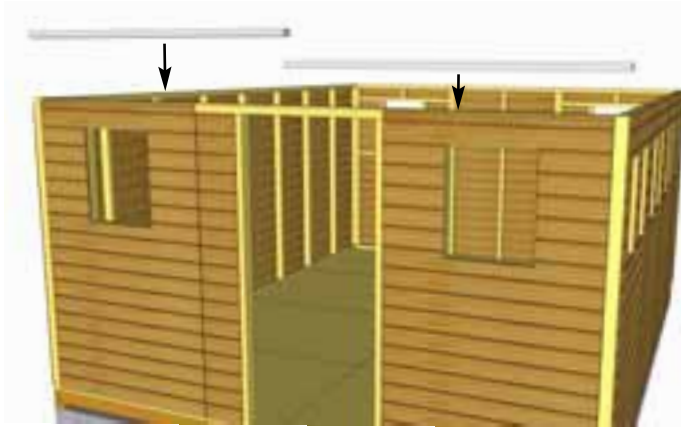

B13. Position and attach **F & R Riser Plates** on top of **Front and Rear Wall Frames**. attach with **4 - 2 1/2" Screws** each. Complete both front and rear of shed.

Parts
F&R Riser Plates
 (1 1/2" x 2 1/2" x 70 3/4") x 4

Hardware
2 1/2" Screws
 x 16 total

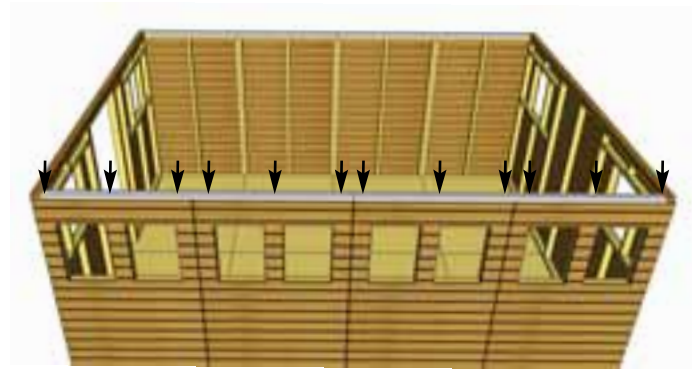
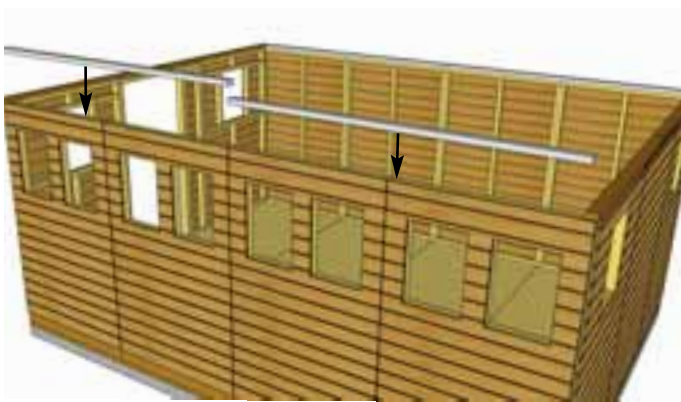

B14. Position and attach **Side Riser Plates** with **6 - 2" Screws** per piece. Complete both sides of shed.

Parts
Side Riser Plates
 (1 1/2" x 2 1/2" x 88 1/2") x 4

Hardware
2" Screws
 x 24 total

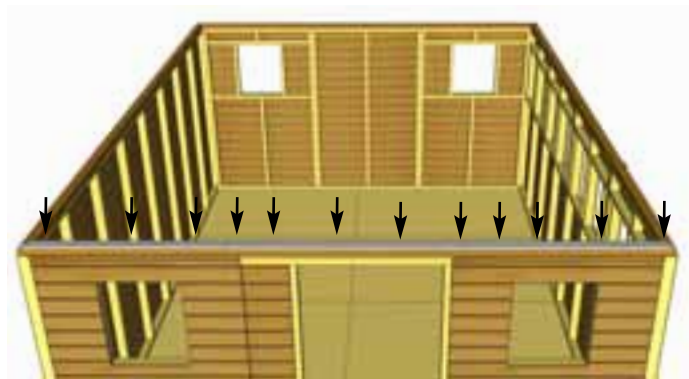
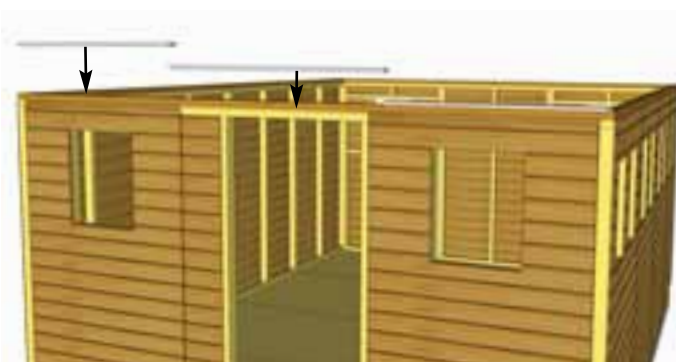

B15. Position and attach **Front & Rear Top Plates**. There are two pieces with angle cut ends and one straight piece per side. Attach with **4 - 1 1/4" Screws** per piece. Complete Front and Rear

Parts
F&R Top Plates Angle
 (3/4" x 2 1/2" x 45") x 4
F&R Top Plates Straight
 (3/4" x 2 1/2" x 51 1/2") x 2

Hardware
1 1/4" Screws
 x 24 total

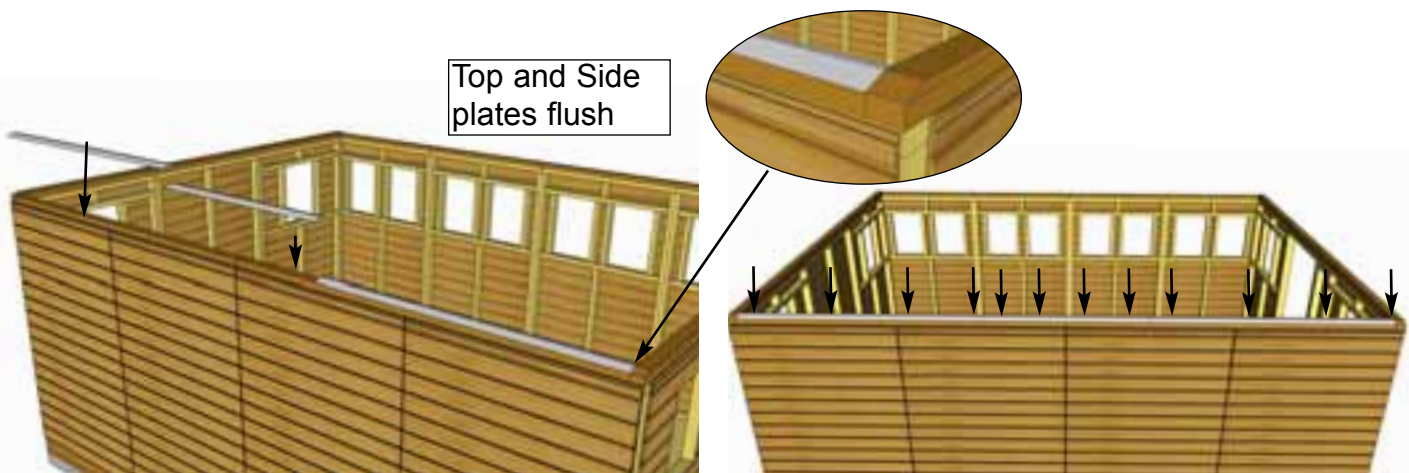

<p>B16. Position and attach Side Top Plates on Side Riser Plates. 65 3/4" side plates are on the outside with the 45 1/2" plate in the center. Angle of Side Plates should match angle of F&R Top Wall Plates. Attach each piece with 4 - 1 1/4" Screws. Complete both sides of shed.</p>	<p><u>Parts</u> Side Top Plates (3/4" x 2 1/2" x 45 1/2") x 2 (3/4" x 2 1/2" x 65 3/4") x 4</p>	<p><u>Hardware</u> 1 1/4" Screws x 24 total</p>
---	---	--

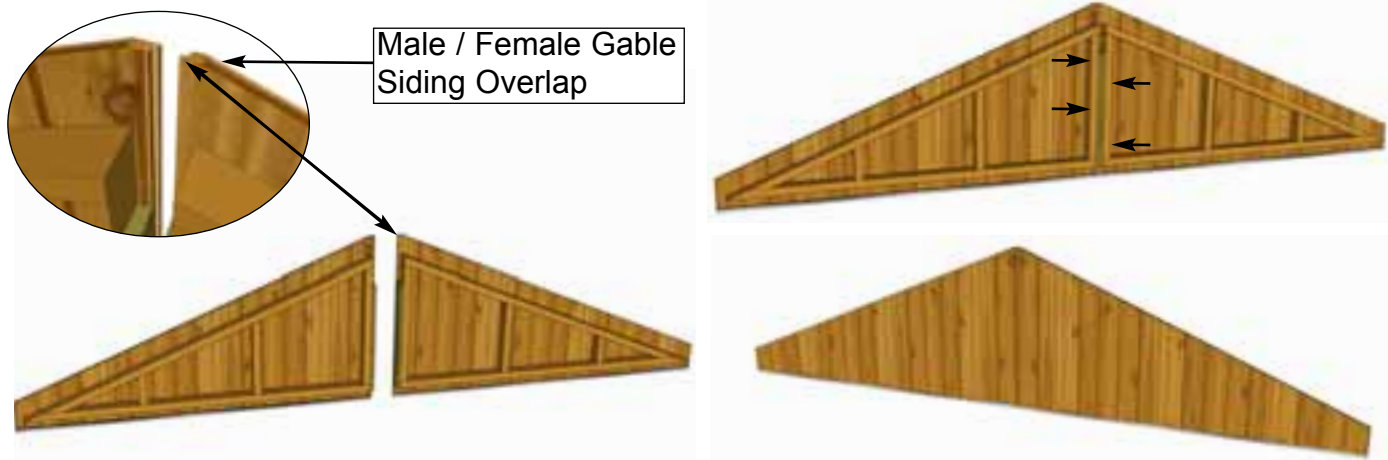

<p>B17. Locate Triangular Gable Half Walls for both sides of shed. Align framing and wall siding lap together. Screw center wall framing of each piece together with 4 - 2 1/2" screws. Note: Prior to attaching, try each combination of Gables for best fit.</p>	<p><u>Parts (Steps B20 - B21)</u> Gable Half Walls x 4</p>	<p><u>Hardware (Steps B20 - B21)</u> 2 1/2" Screws x 8 total 2" Screws x 8 total</p>
---	--	--

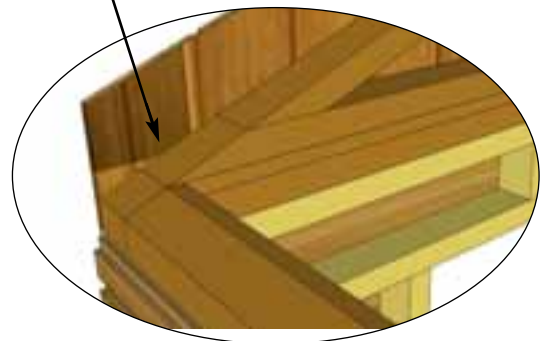
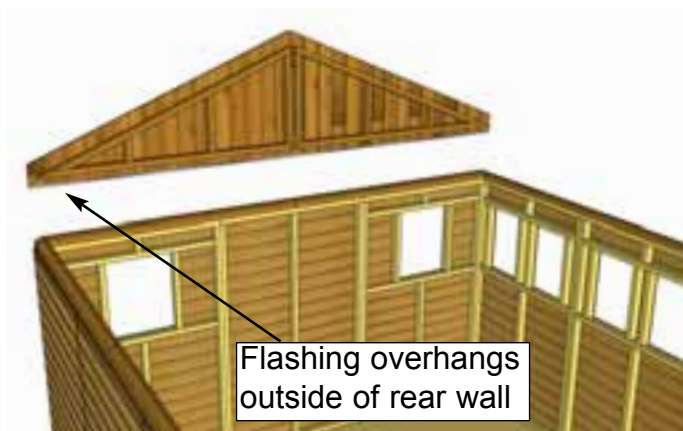

B18. Place completed **Gable Section** so framing sits flush with the inside of the **Top Wall Plate**. It should also be centered side-to-side on the **Top Wall Plate**. Gable Flashing overhangs wall on the outside. Temporarily attach **Gables** to **Top Wall Plate** with **4 - 2" screws**. Gables may need slight adjustment in **Step C11** when attachment will be completed with an additional 6 screws. Screw from the bottom of **Gable** framing down into **Top Wall Plate** and **Wall Framing**. Complete **Gable** positioning and attachment on the other side. **Hint:** Use a straight edge to check the angle of the Gable framing and Top Plate. Both angles should lineup at 22.5°.

C. Rafter Section

Exploded view of all parts necessary to complete the Rafter Section. Identify all parts prior to starting.

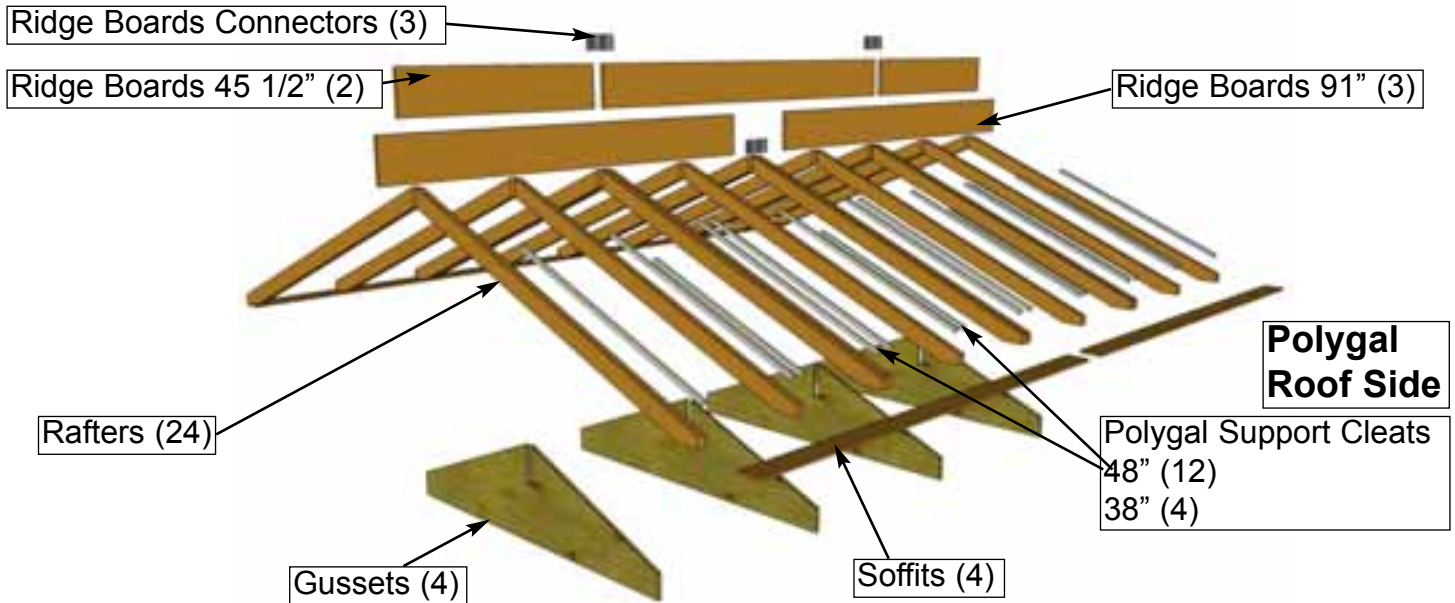

Important: Locate all parts necessary to assemble each Rafter Section prior to beginning.	
Parts for One Rafter Section (Polygal Side): 12 - 1 1/2" x 3 1/2" x 80 7/8" - Rafters 2 - 3/4" x 9 1/4" x 91" - Ridge Board 2 - 1/2" x 4 1/2" x 91" - Soffits 12 - 3/4" x 3/4" x 48" - Polygal Support Cleats 4 - 3/4" x 3/4" x 38" - Polygal Support Cleats * Must complete 2 Rafter Sections	Parts for Other Rafter Section (Non-Polygal Side): 12 - 1 1/2" x 3 1/2" x 80 7/8" - Rafters 2 - 3/4" x 9 1/4" x 45 1/2" - Ridge Boards 1 - 3/4" x 9 1/4" x 91" - Ridge Board 2 - 1/2" x 4 1/2" x 68 1/4" - Soffits Remaining Rafter Pieces: 4 - 3/4" x 80" x 19 3/4" - Gussets

Follow **Steps C1-C15** to Assemble Rafter Sections. Make sure to complete on a flat, level surface.

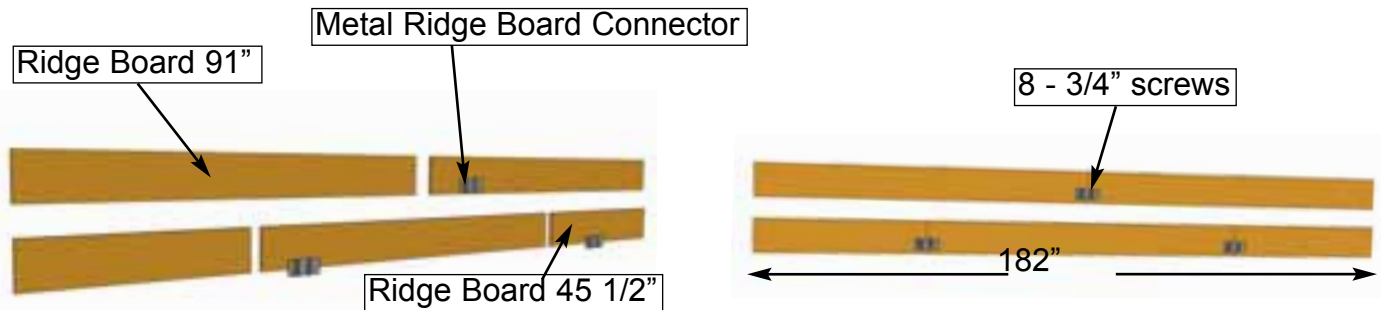

C1. Locate Ridge Boards and attach together using Metal Ridge Board Connectors and 8 - 3/4" screws evenly spaced on boards per connector. Place connector approximately 1 1/4" up from bottom of Ridge Board . Total length when connected is 182". Complete two Ridge Boards .	Parts (Steps C1) Ridge Boards (3/4" x 9 1/4" x 45 1/2") x 2 (3/4" x 9 1/4" x 91") x 3	Hardware (Steps C1) 3/4" Screws x 24 total Metal Ridge Board Connector x3 total
---	--	--

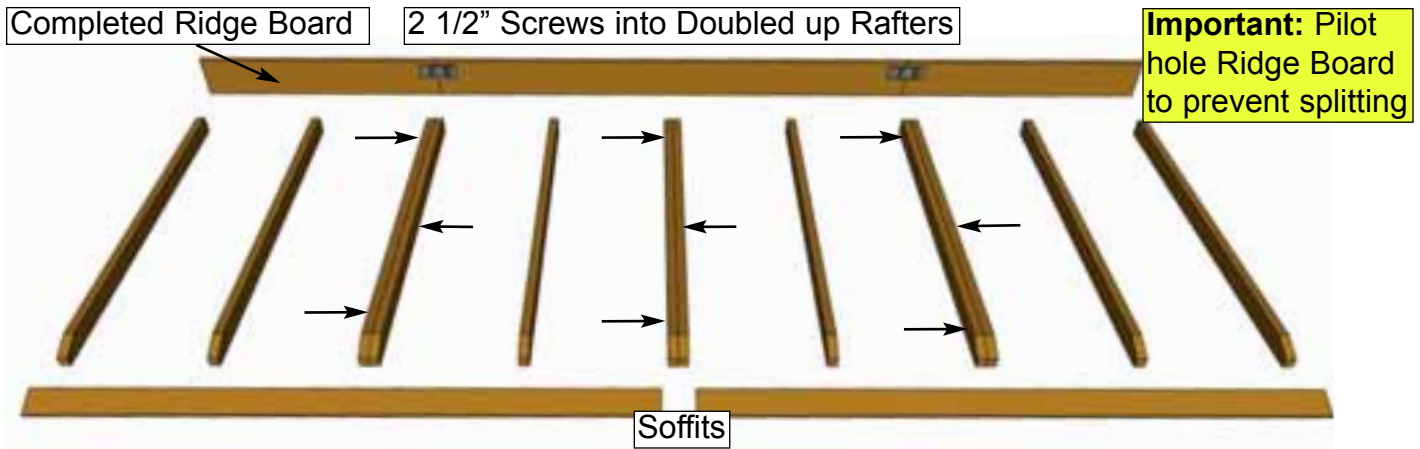

<p>C2. Lay out 12 Rafters, 2 Soffits and the completed Ridge Board from Step 33 on level ground as shown. Double up Rafters as illustrated. Screw doubled up Rafters together with 3 - 2 1/2" Screws. Note: completed rafter section will be flipped over in Step C6.</p>	<p>Parts (Steps C2 - C5)</p>	<p>Hardware (Steps C2 - C5)</p>
	<p>Ridge Boards (3/4" x 9 1/4" x 45 1/2") x 2 (3/4" x 9 1/4" x 91") x 3</p>	<p>2 1/2" Screws x 18 total</p>
	<p>Rafters (1 1/2" x 3 1/2" x 80 7/8") x 24</p>	<p>2" Screws x 48 total</p>
	<p>Soffits (1/2" x 4 1/2" x 91") x 4</p>	<p>1 1/4" Screws x 48 total</p>

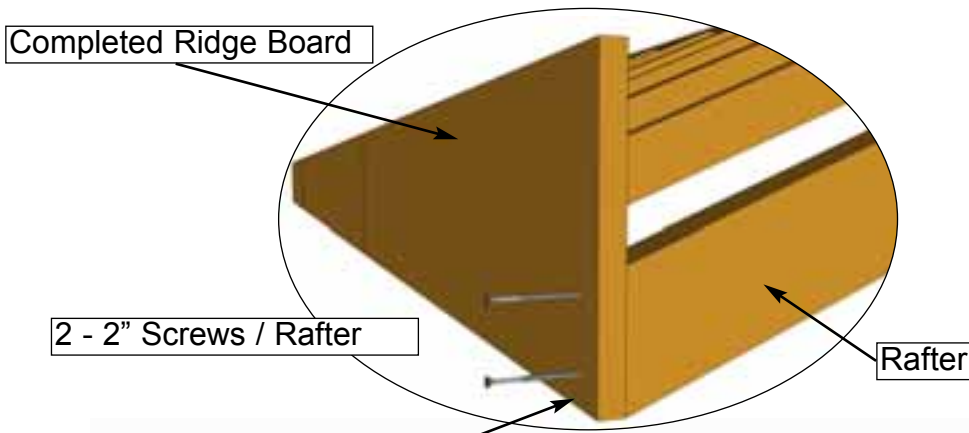

Important: Measure 20 1/2" spacing accurately to accommodate Polygal Panels. See Step 66.

Expert Advice: Use Polygal Panel to confirm correct width

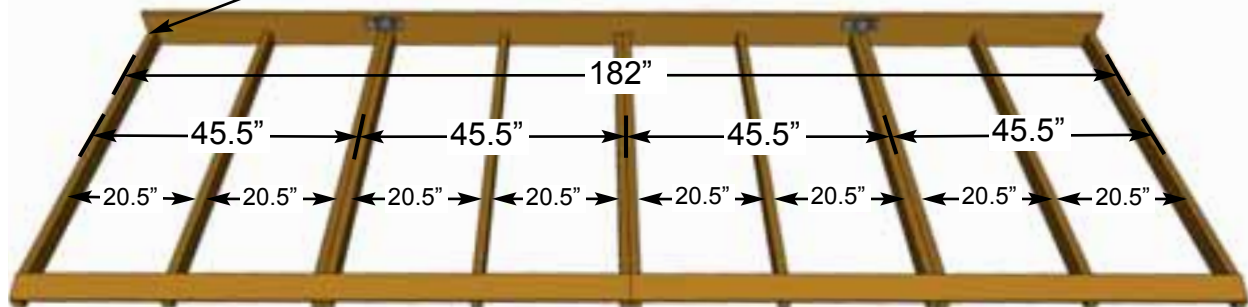

C3. Attach completed Ridge Board to ends of both outside Rafters with 2 - 2" Screws per end. Measure and position interior Rafters as illustrated above. When positioned correctly, attach Ridge Board to remaining Rafters with 2 - 2" Screws per rafter end. **Important:** Pilot Hole Ridge Board to prevent splitting.

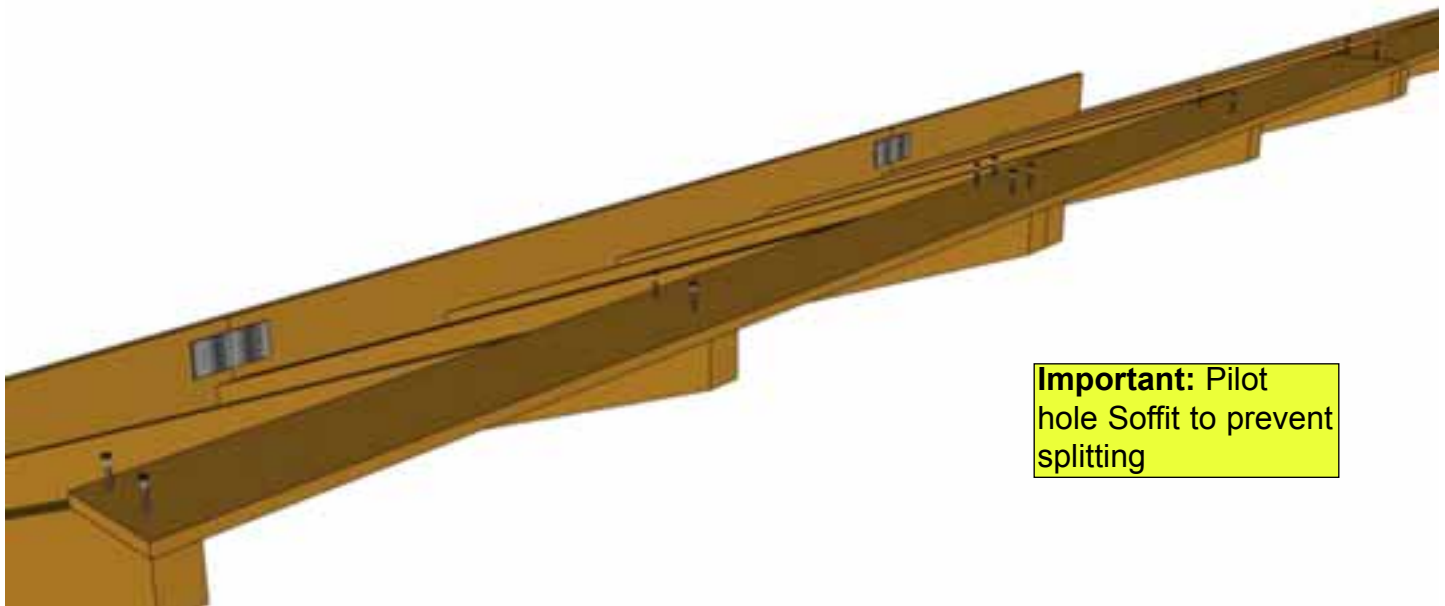

Important: Pilot hole Soffit to prevent splitting

C4. Attach end **Soffit** Board flush to ends of outside **Rafters** with 2 - 1 1/4" Screws per **Rafter** end. Complete both outside **Rafter/Soffit** connections first. Measure and position interior **Rafters** as illustrated above. When positioned correctly, attach **Soffits** to remaining **Rafters** with 2 - 1 1/4" Screws/**Rafter**. **Important:** Pilot Hole **Soffits** to prevent splitting.

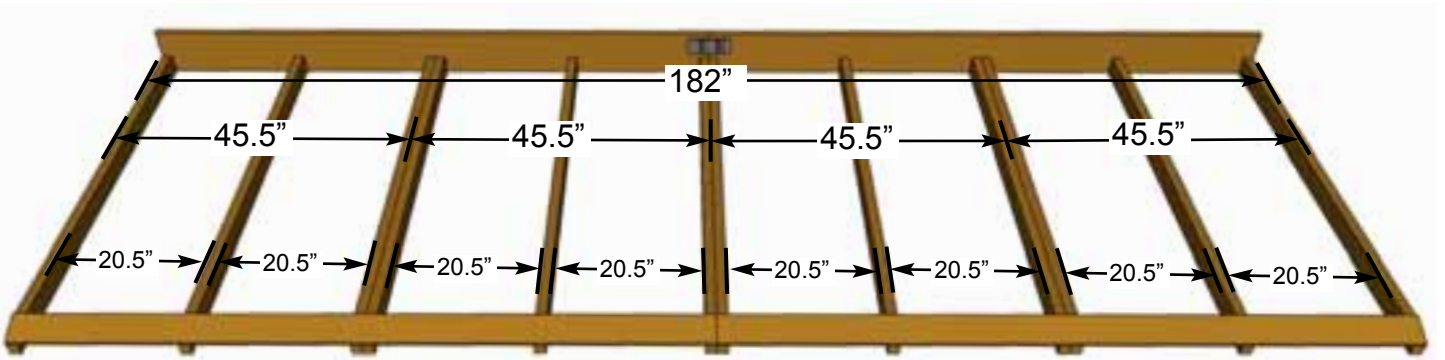

C5. Complete second **Rafter** section following Steps C2 - C4.



Soffits facing the ground

C6. With some helpers flip over each **Rafter** section so they can be lifted onto the shed. **Soffits** should now be on the ground. Prepare to lift onto Wall and **Gable** Frame

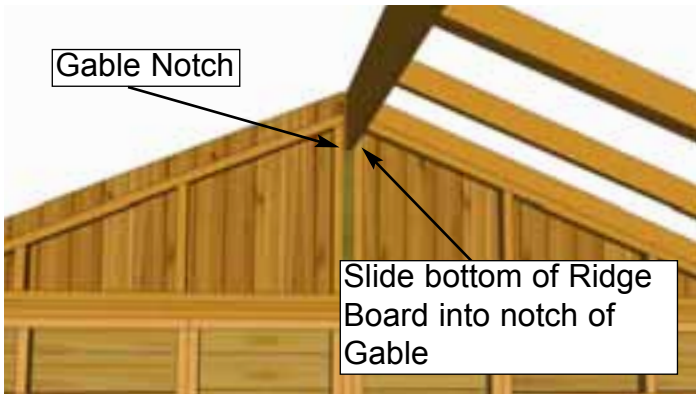

C7. With the assistance of two or more helpers and some ladders, slide first **Rafter Section** up onto **Gable Framing** until bottom of **Ridge Board** slips into gable notch. Position **Rafters** so they sit evenly on **Gable Framing** from side to side. Where **Wall** and **Soffit** meet, a small gap may appear. Confirm all **Rafters** are resting on **Top Plate**.

Ensure Ridge Boards are flush with one another.

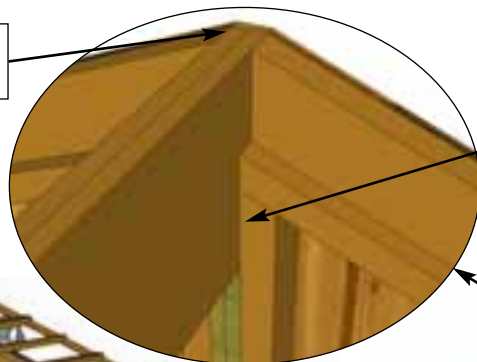

Bottom of Ridge Board fits in gable notch.

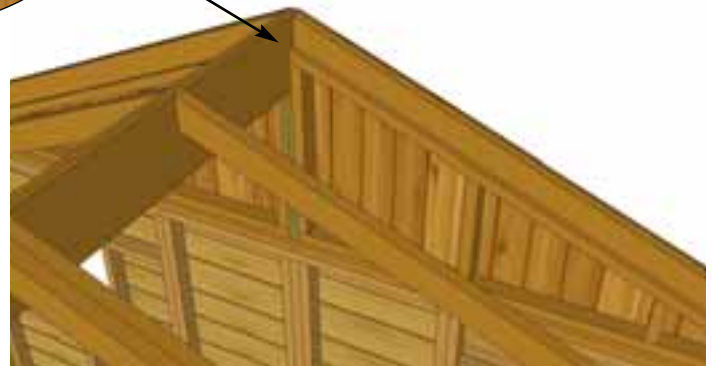

C8. Lift second **Rafter Section** up and place on **Gable Framing**. Slide **Rafter Section** up on framing until bottom of **Ridge Board** slips into Gable notch. **Soffit** will sit approximately 1/8" away from wall as per **Step C7**.

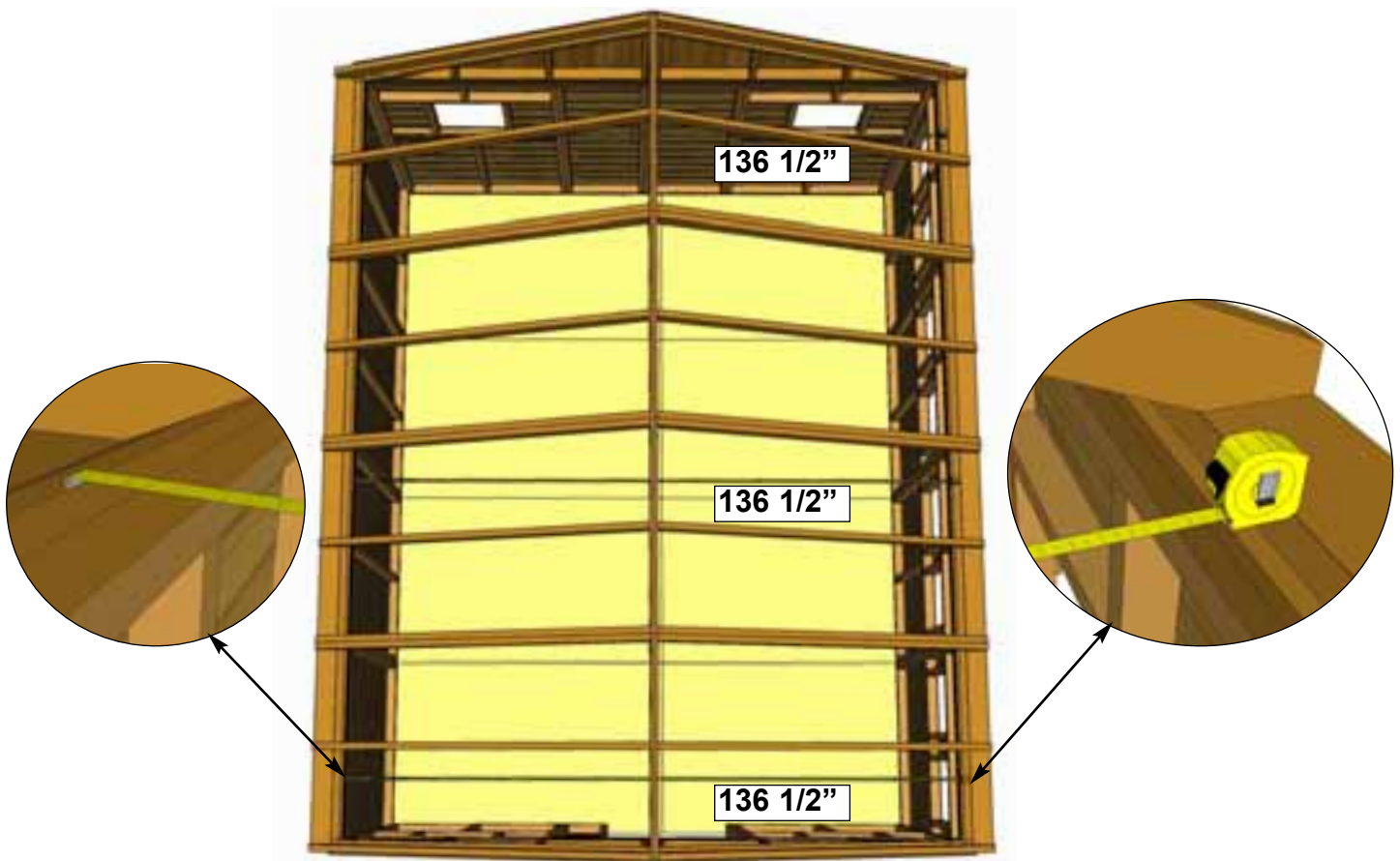

C9. Take the inside-to-inside measurement between **Top Wall Plates** and **Bottom Wall Plates** at the front, middle, and rear of your shed. These measurement should each be approximately 136 1/2", but more importantly, if they are not within 1/4" of each other, your walls are not square.

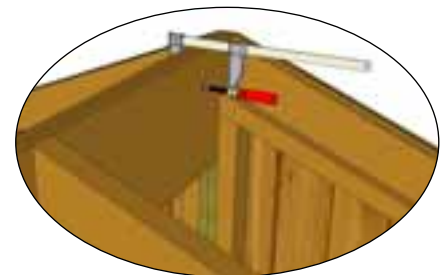
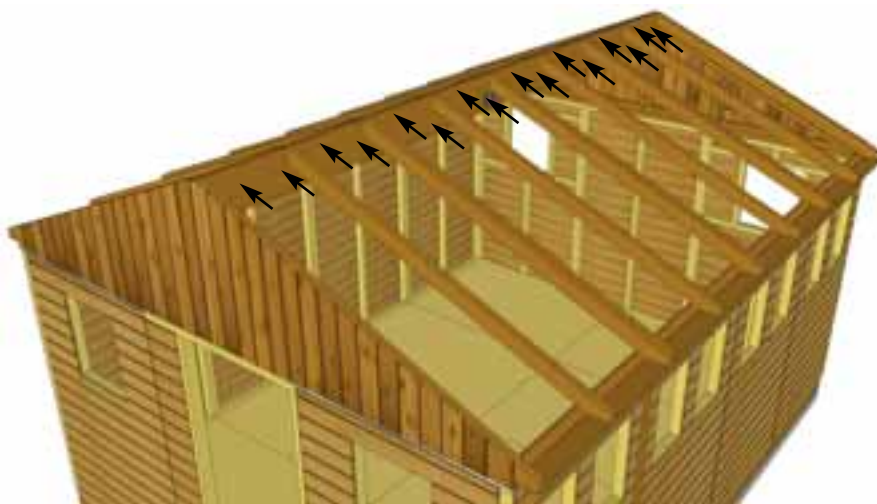

Advice: It may be helpful to use a clamp to help hold Ridge Boards together flush while screwing.

C10. Where **Ridge Boards** meet, press together and secure with **16 - 1 1/4" Screws** per side. We recommend using a clamp to hold the **Ridge Boards** together flush while screwing. Stagger screw position vertically on **Ridge Board** to create a stronger connection. Complete both sides, Important: if there is a gap between **Ridge Boards**, try pushing side walls closer together from outside. Walls should be 136 1/2" apart at top from inside of wall plate to wall plate as per **Step C7**.

Hardware (Steps C10)
1 1/4" Screws
 x 32 total



Important: If Gable framing does not line up with Rafters, remove temporary 2" screws from Gable framing. Re align gable and then secure.

C11. With both Rafter Sections correctly aligned, secure Gable Framing to both outside Rafters with 8 - 2" Screws per side at top and with 8 - 2" Screws into Top Wall Plates at bottom.

Hardware (Steps C11)
2" Screws
x 32 total

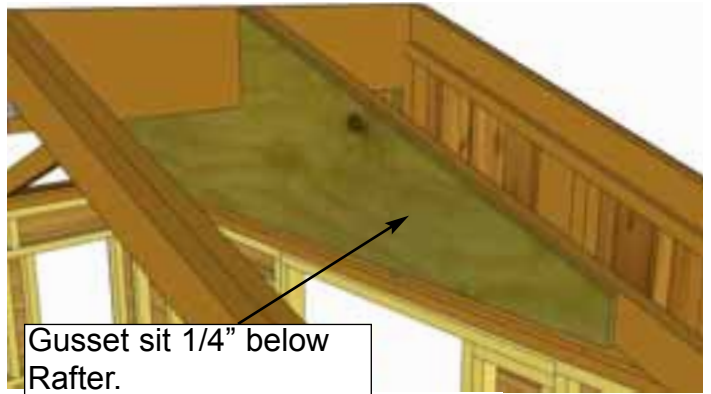

Gusset sit 1/4" below Rafter.

C12. Start by attaching one Gusset onto the middle Rafters as illustrated. Attach only 1 - 2" Screw per side now. **Important:** Pilot hole Gussets to prevent splitting.

Parts (Steps C12 - C13)
Gussets
(3/4" x 80" x 19 3/4") x 4

Hardware (Steps C12 - C13)
2" Screws
x 40 total

Important: Before attaching remaining Gussets, recheck the inside-to-inside wall measurements are done.. Use a level to check they are square.



C13. Once walls are confirmed to be square and plumb, attach the remaining 3 Gussets with 10 - 2" Screws per Gusset. Gussets attach to single Rafters. Attach remaining screws to Gusset that was attached in Step 46. **Important:** Pilot hole ends of Gusset to prevent splitting.

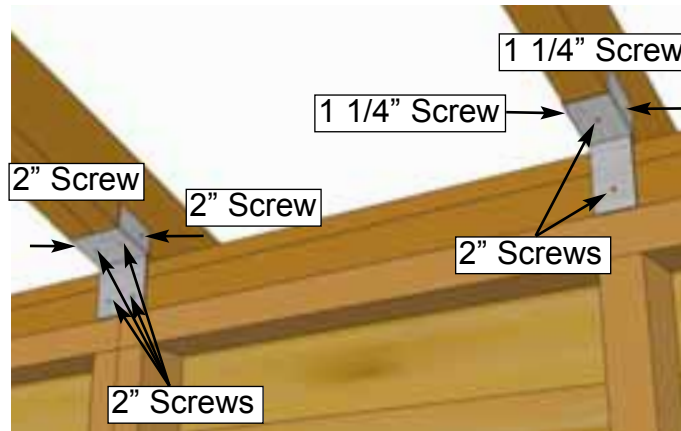

C14. Attach all Single and Double Rafter Brackets where Rafters meet Top Wall Plates inside of shed. Attach with 2 - 1 1/4" Screws and 2 - 2" Screws per Single Rafter Bracket and 6 - 2" Screws per Double Rafter Bracket.

Hardware (Steps C14)
 Single Rafter Bracket x 8 total
 Double Rafter Bracket x 6 total
 1 1/4" Screws x 16 total
 2" Screws x 52 total

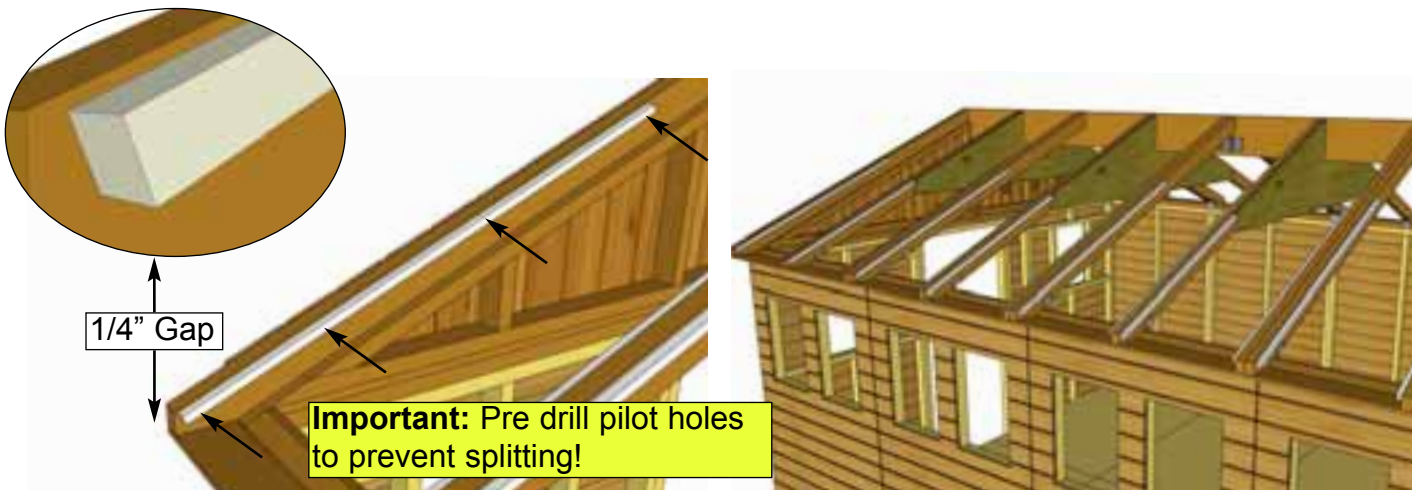

C15. Position Polygal Support Cleats alongside Rafters. Leave a 1/4" gap down from top of Rafter. The shorter Cleat is for the Rafters with a Gussset attached. Secure each Cleat to Rafter with 4 - 1 1/4" Screws. Ensure to pre-drill pilot holes to avoid splitting Complete remaining Polygal Support Cleats.

Parts (Step C15)
 Polygal Support Cleats Short
 (3/4" x 3/4" x 38") x 4
 Polygal Support Cleats Long
 (3/4" x 3/4" x 48") x 12

Hardware (Step C15)
 1 1/4" Screws
 x 64 total

D. Roof Section - Cedar

**Exploded view of all parts necessary to complete the Roof Section.
Identify all parts prior to starting.**

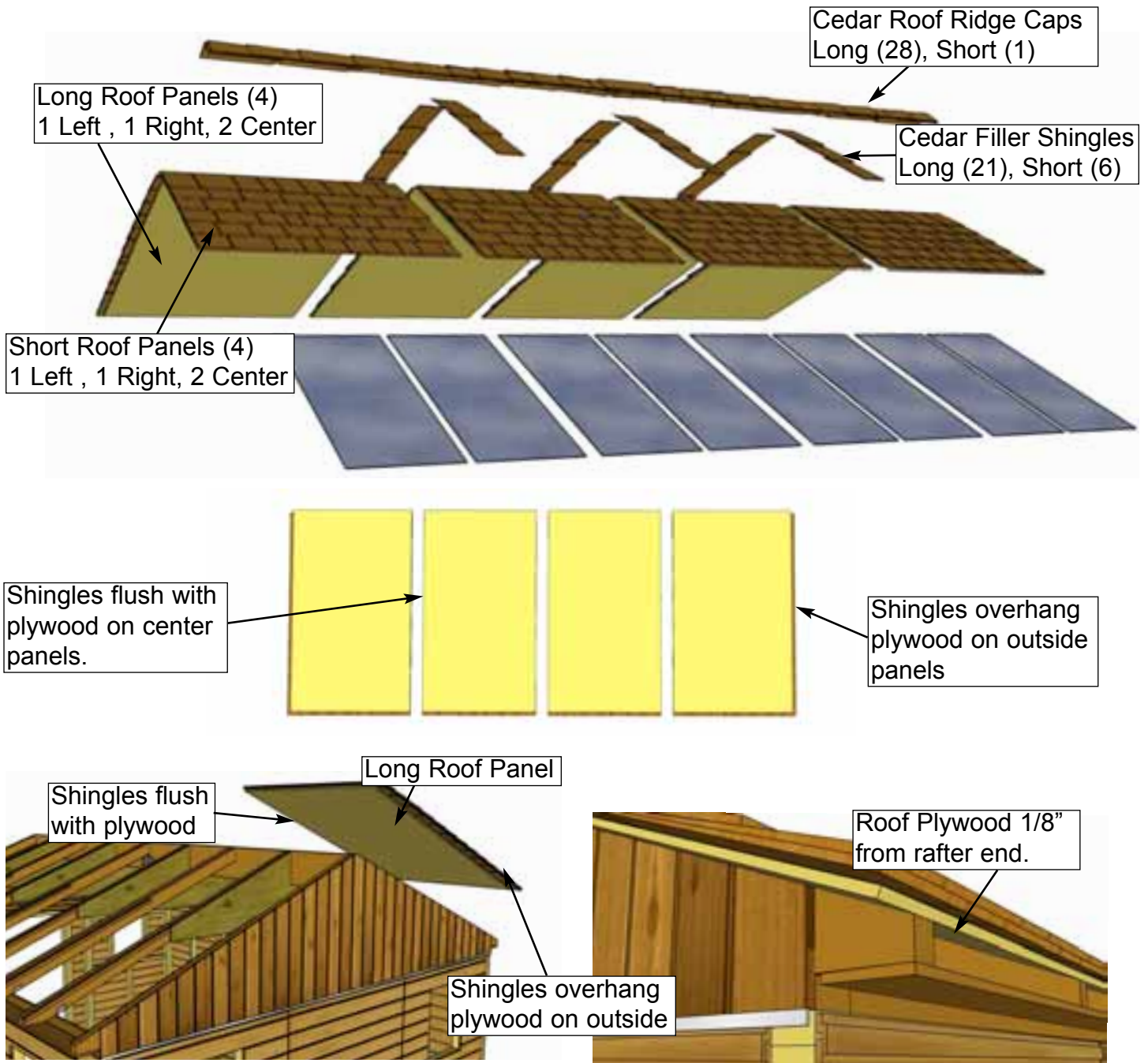

D1. Identify Roof Panels. There are 4 **Long Roof Panels** and 4 **Short Roof Panels**. Start on the long side of roof (side without polygal support cleats). Lift the long left panel onto roof such that the roof plywood is 1/8" from end of roof rafter.

Parts (Step D1 - D5)
Long L&R Roof Panels
 (48" x 81") x 2
Long Center Roof Panels
 (45 1/2" x 81") x 2

Hardware (Step D1 - D5)
2 1/2" Screws
 x 6 total

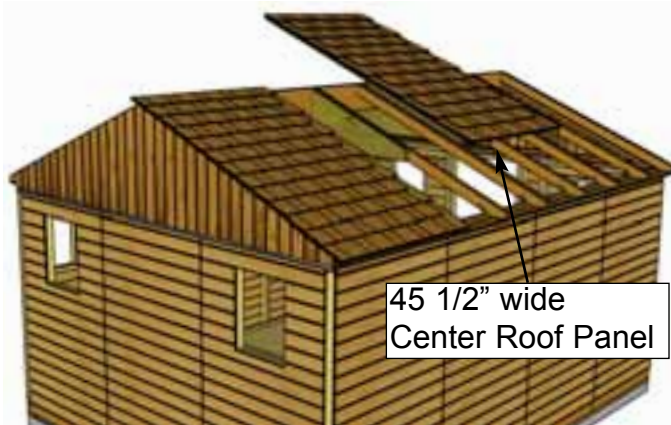
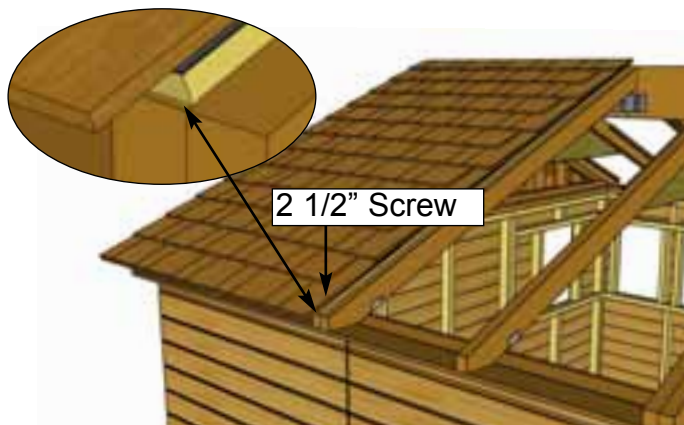

D2. Position Panel so roof plywood sits evenly on doubled up Rafters. Screw Panel to Rafters through bottom row of shingles with 1 - 2 1/2" Screw. Lift up and place a Long Center Roof Panel on Rafters. Center Panel will have plywood flush with shingles on both sides. Position evenly on Rafters.

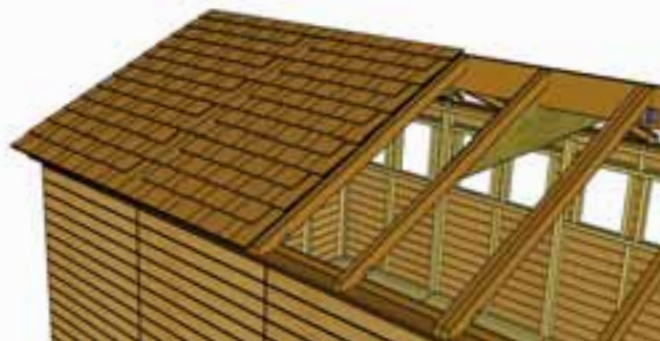

D3. Position Center Roof Panel so plywood is 1/8" from end of Rafters as per Step D1. From side-to-side, make sure Roof Panel is sitting equally on rafters. When positioned correctly, screw down with 2 - 2 1/2" Screws into outside lower shingles.

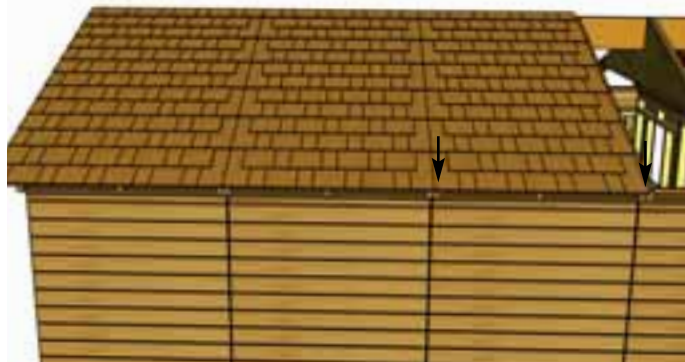

D4. Locate 2nd Center Roof Panel and position so plywood is 1/8" from end of Rafters as per Step D1. From side-to-side, make sure Roof Panel is sitting equally on rafters. When positioned correctly, screw down with 2 - 2 1/2" Screws into outside lower shingles.

Shingles overhanging outside of roof plywood



D5. Lift up and place remaining **Long Outside Roof Panel** on Rafters. With **Outside Roof Panel** centered on rafter and aligned as per **Steps D1 - D2**, screw panel down with **1 - 2 1/2" Screw**.

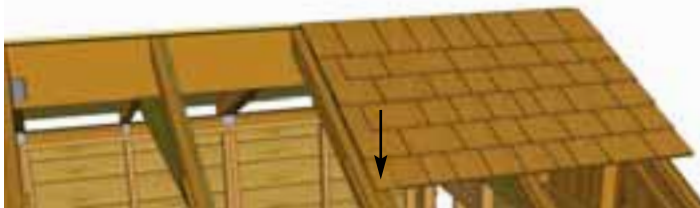

Small Gap between roof panels at peak

D6. Locate **Short Right Roof Panel**. Lift and place panel on polygal side of roof. Position **Short Right Roof Panel** equally on seam of doubled up Rafter as per **Step D2**. Align Roof Panel at top so even with long panel at peak. Reach through opening in Rafters to attach. When positioned correctly, screw down with **1 - 2 1/2" Screw** in bottom row of shingles as illustrated above. **Hint:** work from inside of shed to position and secure Polygal Side Roof Panels.

Parts (Step D6 - D7)
Short L&R Roof Panels
 (48" x 37 1/2") x 2
Short Center Roof Panels
 (45 1/2" x 37 1/2") x 2

Hardware (Step D6 - D7)
2 1/2" Screws
 x 6 total

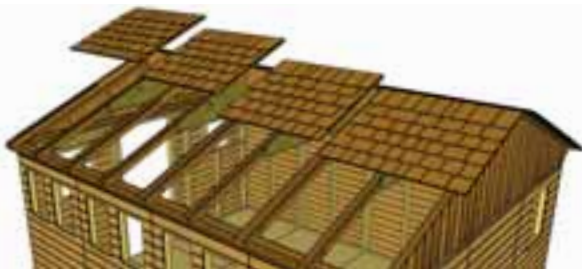

D7. Repeat **Steps D3 - D5** to attach remaining panels on short roof side. Align evenly at roof peak.

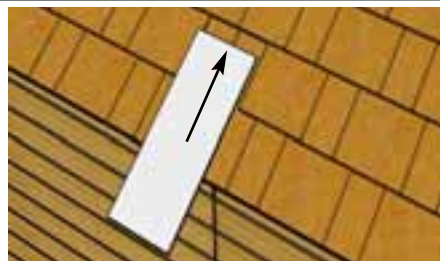

D8. **Roof Filler Shingles** are included to cover roof seams. Starting at the bottom, slide the first Long shingle in until flush with other bottom shingles.

Parts (Steps D8 - D10)
Filler Shingles - Long x 21
Filler Shingles - Short x 6

Hardware (Steps D8 - D10)
2 1/2" Screws
 x 21 total

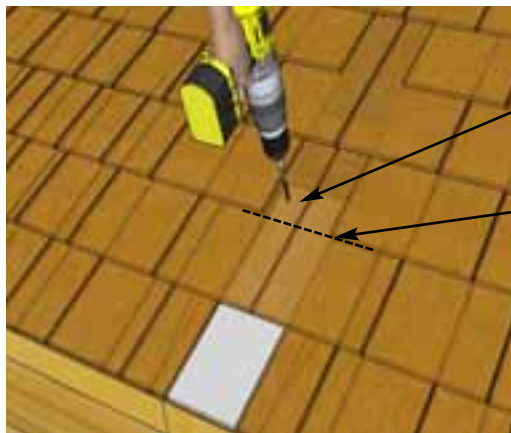

Attach above the exposure line.

Exposure Line

D9. Screw first **Filler Shingle** down to rafters using **1 - 2 1/2" Screws** (1 per panel). Make sure to screw into both rafters.

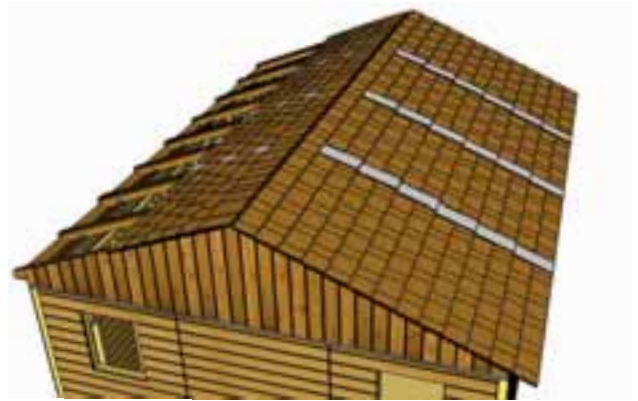
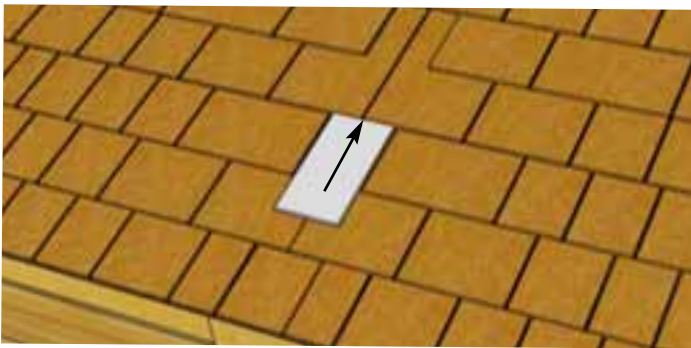

D10. Slide in another **Filler Shingle** and attach as per **Step D9**. On your last row of shingles, attach smaller **Filler Shingles** with **2 - 1 1/2" Shingle Nails** near the top, to be covered by **Ridge Caps** in **Step D13**. Complete both rows of **Filler Shingles** where roof seams meet in the same way.

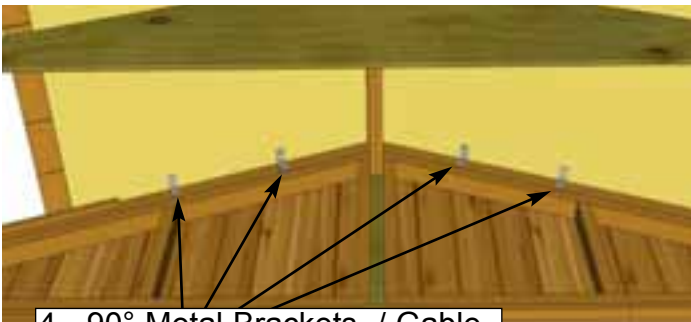

4 - 90° Metal Brackets / Gable.

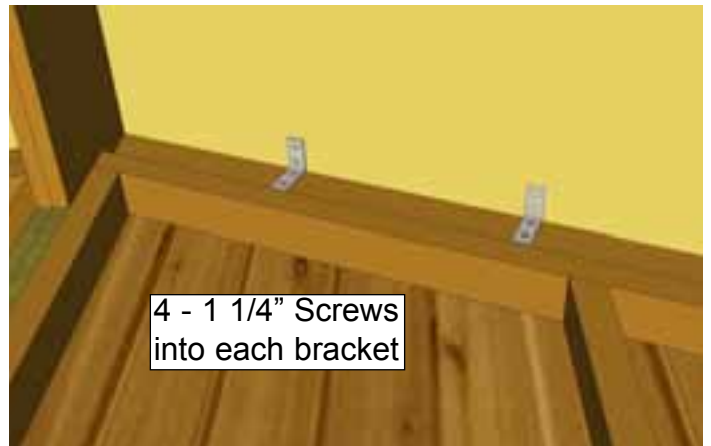

4 - 1 1/4" Screws into each bracket

D11. Position **4 - 90° Metal Brackets** onto the roof plywood and outside Rafter and secure with **4 - 1 1/4" Screws** each. Complete for both Gables. There are 8 brackets total (4 per side).

Hardware (Step 60)

1 1/4" Screws

x 32 total

90° Metal Bracket

x 8 total

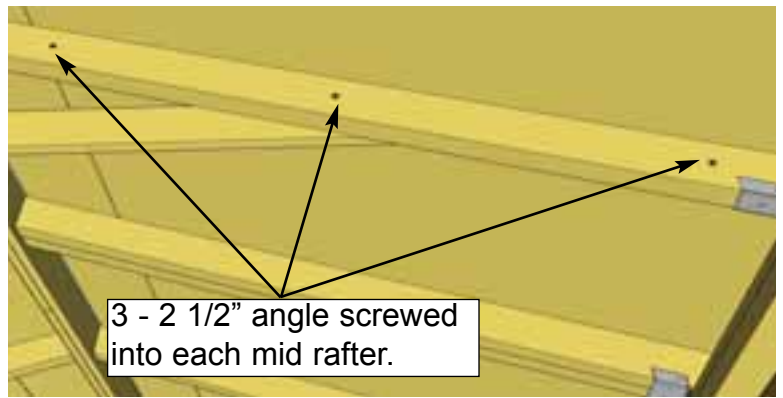
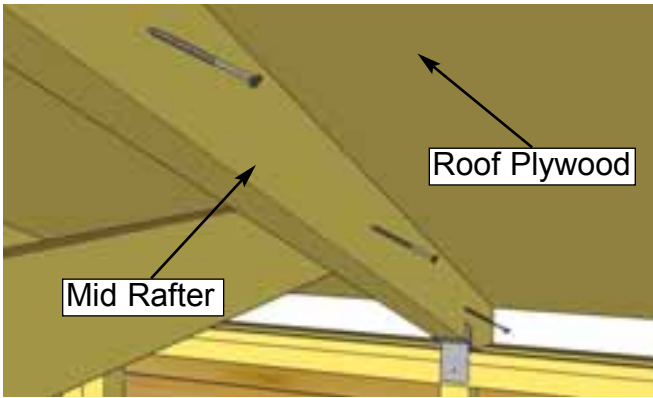

D12. To further secure roof panels, from the inside, drill 1/8" pilot holes in each single rafter (3 per rafter) on an angle. Using 3 - 2 1/2" Screws, per rafter secure rafters to roof plywood. **Note:** from outside, have a helper push roof panel down so plywood sits flush against rafter when securing.

Hardware (Step D12)
 2 1/2" Screws
 x 24 total

Alternate Ridge Cap seams (offsetting angle cut at peak)

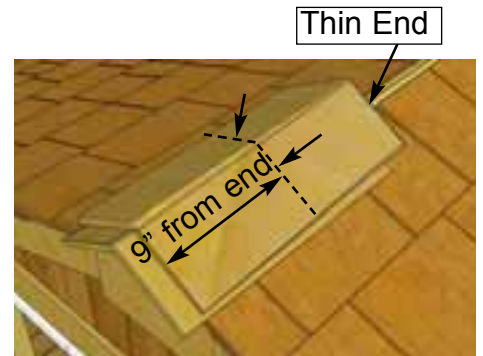
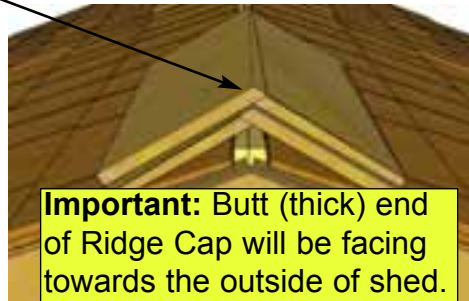
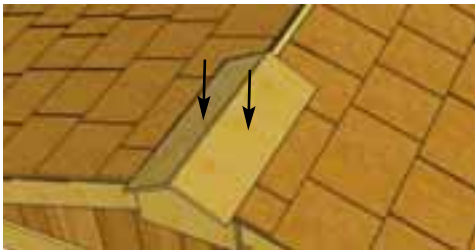

D13. Place 1st **Roof Ridge Cap** on roof peak overhanging shingles by approximately 1". Attach with 2 - 1 1/2" **Shingle Nails** 9" from end. Place 2nd Ridge Cap 1" back from first cap. Attach with 2 - 1 1/2" **Shingle Nails** 9" from end. Alternate each Ridge Cap seam as you proceed.

Parts (Steps D13 - D14)
 Roof Ridge Caps Long x 28
 Roof Ridge Caps Short x 1

Hardware (Steps D13 - D14)
 1 1/2" Shingle Nails
 x 60 total

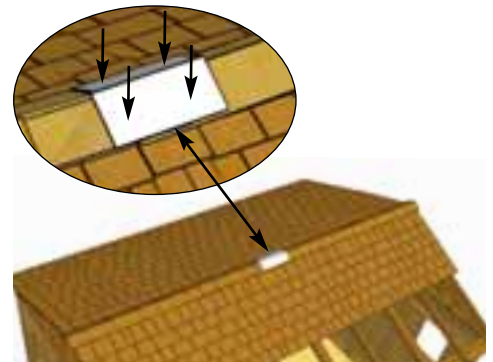
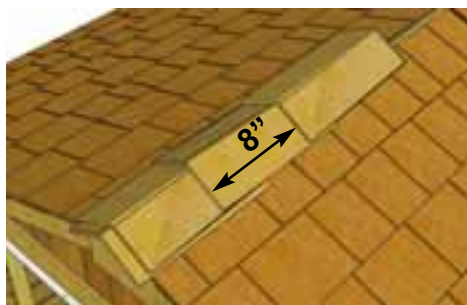

D14. Place 3rd **Ridge Cap** 8" back from 2nd (enough to cover shingle nails). Attach 3rd Ridge Cap as per **Step D13**. Continue to position and attach Ridge Caps until half the roof is complete. From opposite side, position and attach Ridge Caps as described above. One Ridge Cap is cut shorter to fit in the center of the roof. Attach center cap with 4 - 1 1/2" **Shingle Nails**.

D. Roof Section - Metal

Exploded view of all parts necessary to complete the Roof Section. Identify all parts prior to starting.

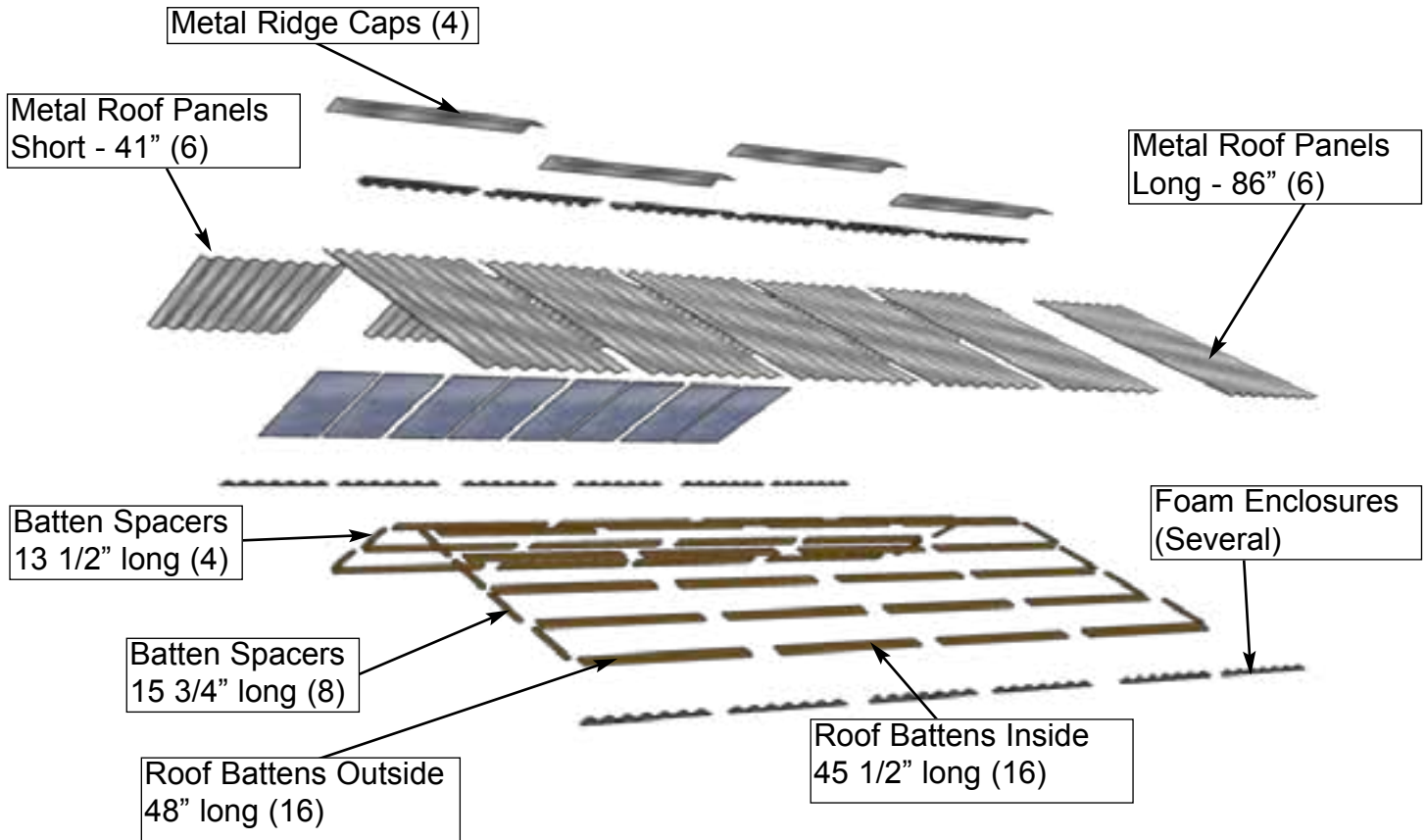

Polygal Side

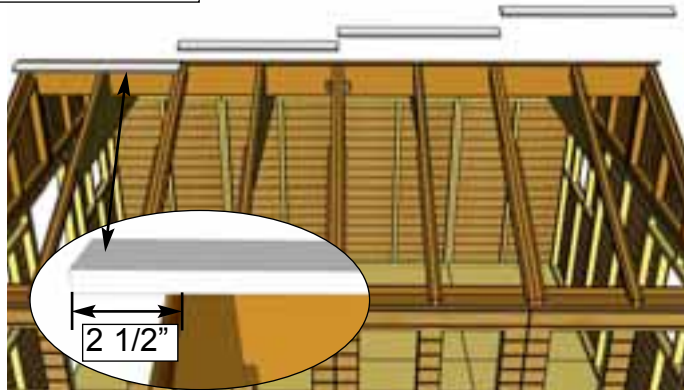

Flush to Ridge Board



D1. Start on Poygal side of Roof. Locate 2 **Outside Roof Batts** and 2 **Inside Roof Batts**. Place Batts on top of Rafter section where Rafters and Ridge Boards meet. Batten will overhang outside Rafter by 2 1/2\".

Parts (Steps D1 - D6) Outside Batts (3/4" x 3 1/2" x 48") x 16 Inside Batts (3/4" x 3 1/2" x 45 1/2") x 16	Parts (Steps D1 - D6) Batten Spacer Long (3/4" x 1 1/2" x 15 3/4") x 8 Batten Spacer Short (3/4" x 1 1/2" x 13 1/2") x 4
Hardware (Steps D1 - D6) 1 1/4" Screws x 120 total	

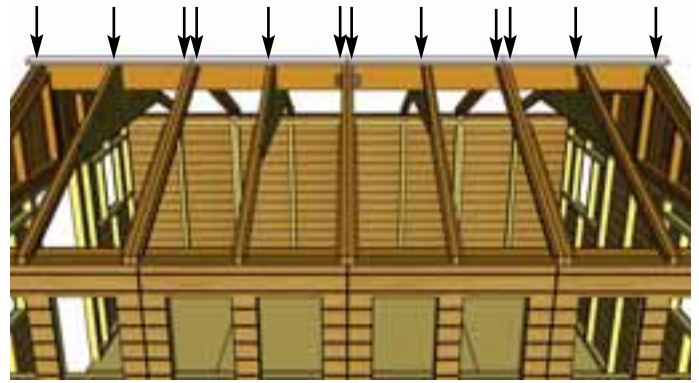
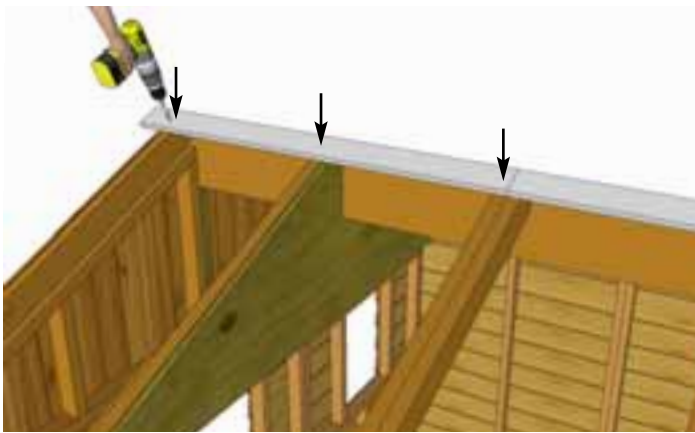

D2. Attach **Battens** to Rafters with **12 - 1 1/4" Screws** per row (3 screws per Batten). **Important:** Pre-drill pilot holes with 1/8" drill bit first to prevent ends from splitting.

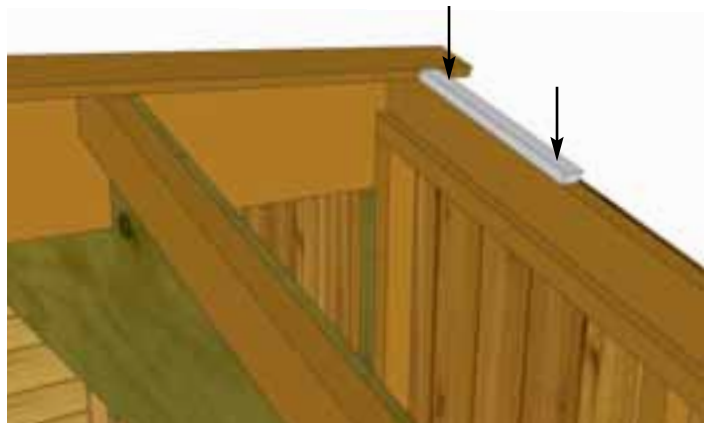
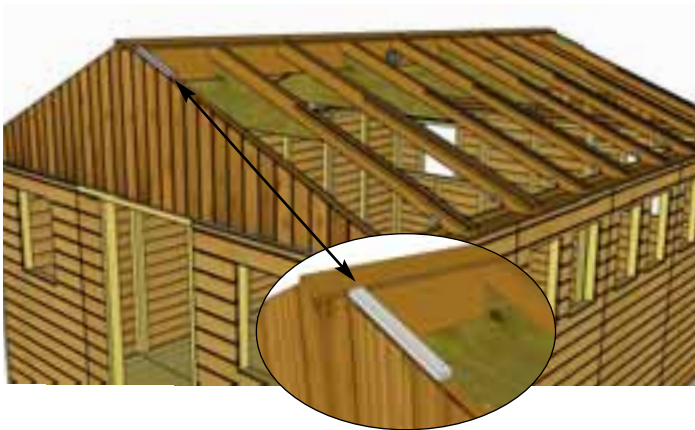

D3. Place **Batten Spacer Short** flush with first set of Battens on outside Rafter. Batten Spacer allows you to line up next row of Battens. Attach each **Batten Spacer** with **2 - 1 1/4" Screws**.

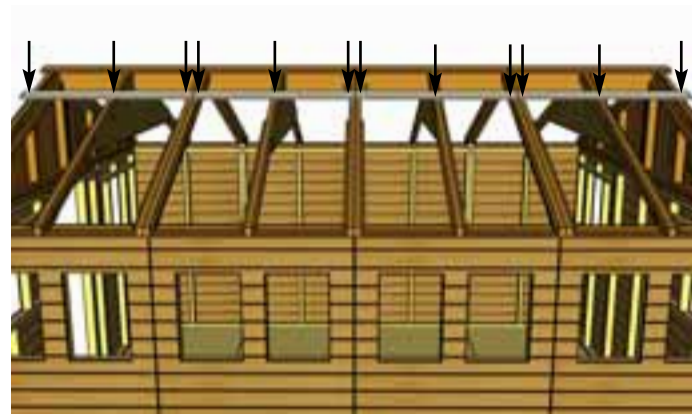

D4. Locate 2 more **Outside Roof Battens** and 2 more **Inside Roof Battens**. Place outside Battens flush with Batten Spacers and overhanging outside Rafter by 2 1/2". Secure row of Battens to Rafters with **12 - 1 1/4" Screws** as per **Step D2**.

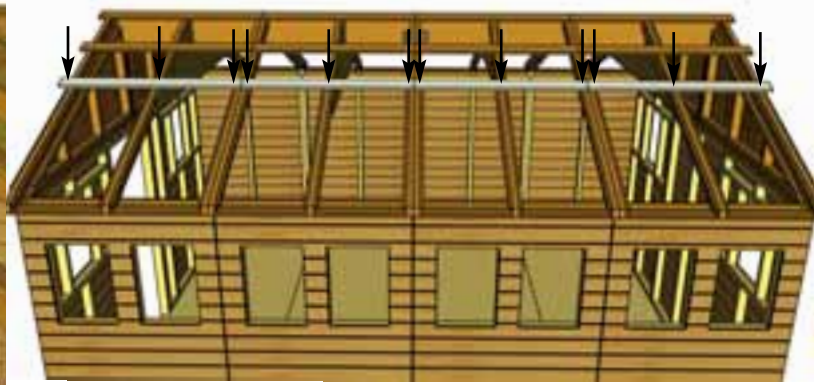
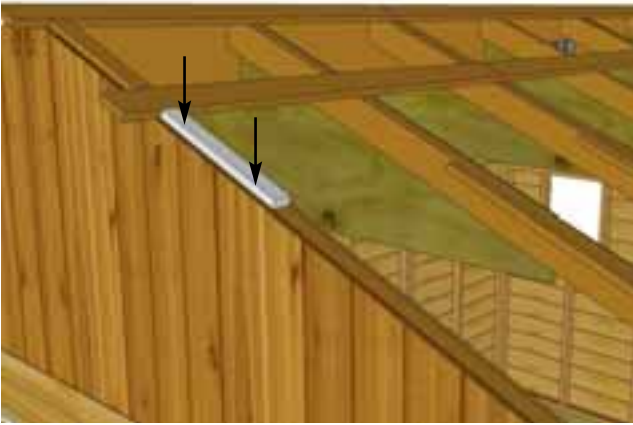

D5. Locate another pair of **Batten Spacers Short** and position flush with second row of Battens on outside Rafter. Attach Batten Spacers to outside Rafter with 2 - 1 1/4" Screws per spacer. Locate 2 more **Outside Roof Battens** and 2 more **Inside Roof Battens**. Attach row of Battens to Rafter with 12 - 1 1/4" Screws for the row as per Step D2.

Non-Polygal Side

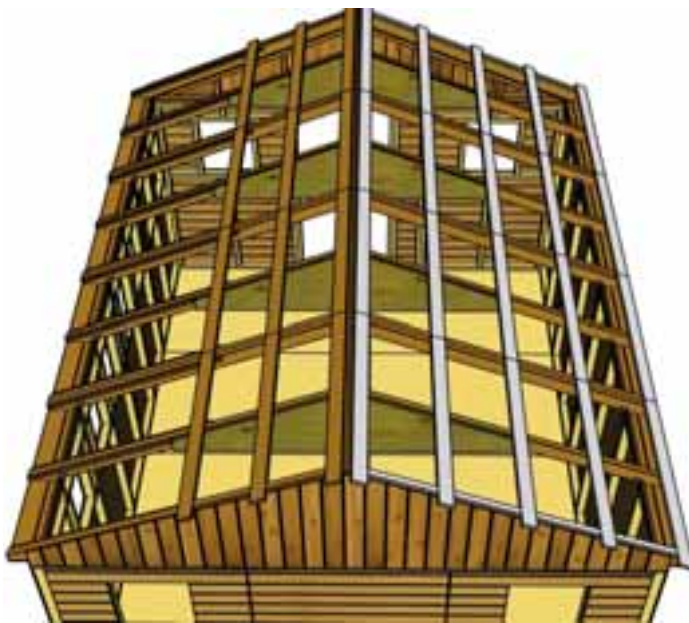

D6. Switch to opposite side of Roof. Complete second side of Roof by repeating Steps D1 - D5. Second half of Roof has 5 rows of Battens and uses **Batten Spacers Long**.

Metal Roof Panels overlap each other

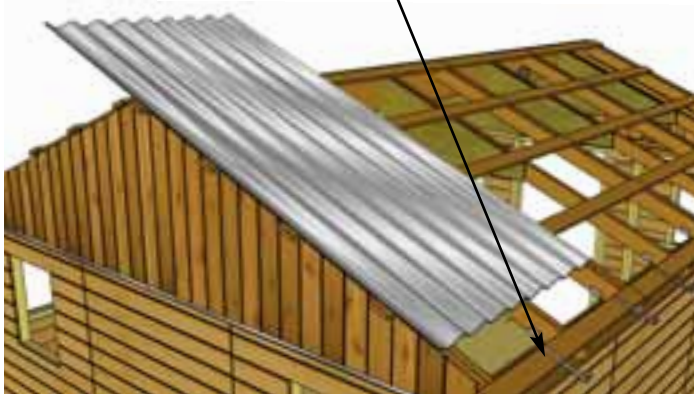
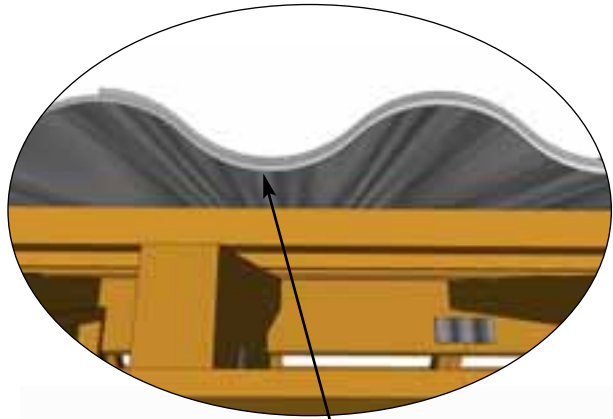
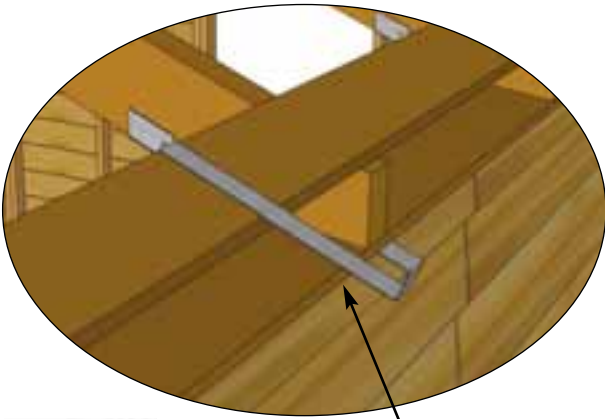

D7. Locate all **Metal Roof Panels** and **Metal Roof Hangers**. To temporarily help hold the **Metal Roof Panel Long** in place, hook a **Metal Roof Hanger** onto the lower **Batten** approximately where the center of the first panel will be. Place the first **Metal Roof Panel Long** on **Battens**. Do not fasten Panels down until **Step D13**. place remaining **Metal Roof Panels** on **Hangers** the same way.

Parts (Steps D7 - D16)
Metal Roof Panels Long
(86" long) x 6
Metal Roof Panels Short
(41" long) x 6

Hardware (Steps D7 - D16)
2" - Metal Roof Screws
x 54 total

Hardware (Steps D7 - D16)
Metal Roof Hangers
x 6 total

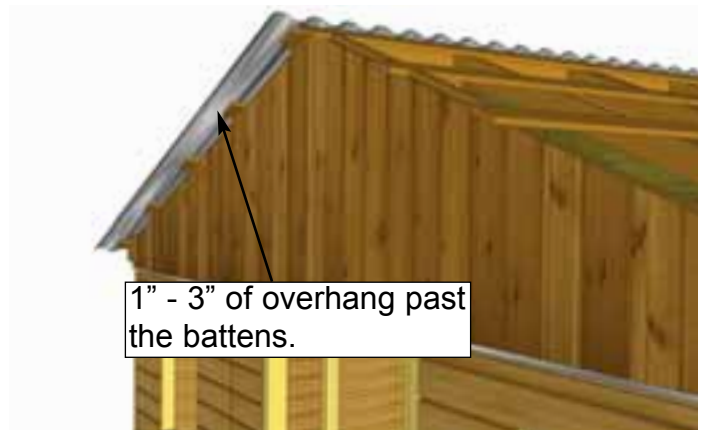

D8. **Metal Roof Panels** overhang on the side of shed should be approximately 4" and is set by **Metal Roof Hangers**. Overall width past the end of **Battens** on front and rear can vary from 1" - 3" depending on your personal preferences. The **Metal Roof Panels** have room to space out to achieve desired overhang.

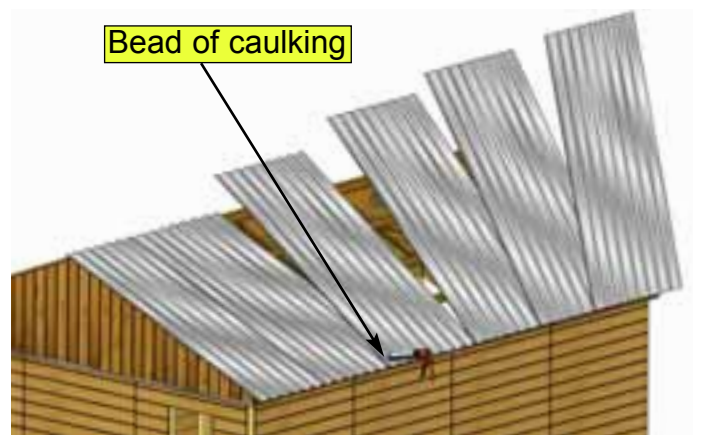

D9. Once the Metal Roof Panels are spaced correctly from side-to-side and top-to-bottom, lift 5 panels up and run a bead of caulking down the overlapping seams of each panel to seal the joints. Place panels down one by one once seam is caulked. You will likely need assistance from a helper for this step.

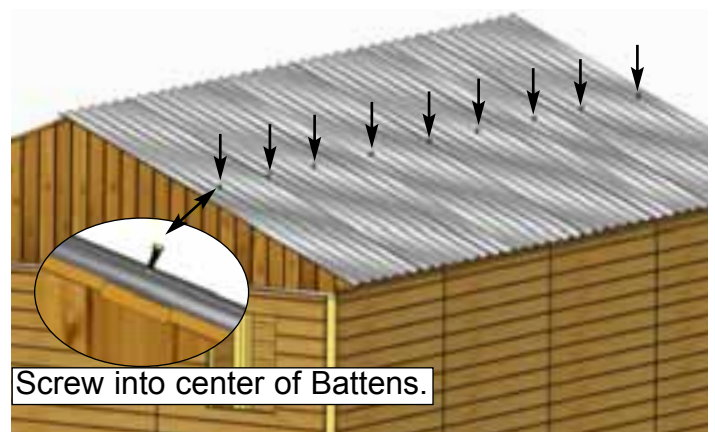

D10. Using 9 - 1 1/2" Metal Roof Screw and 1/4" Nut Driver, partially secure Metal Roof Panels down to the middle Batten row. Only fasten screws half way so the Metal Roof Hangers can be removed. Metal Screw is self-tapping, screw into the center of Battens, 27 more 1 1/2" Metal Screws will be used to secure roof to lower Batten once hangers are removed.

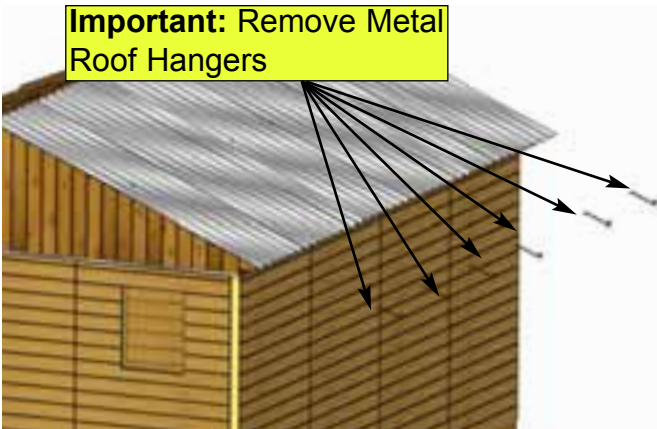

D11. Before fully fastening Metal Roof Panels down, remove Metal Roof Hangers and insert Foam Enclosures between Metal Roof Panels and bottom Battens. Enclosures will prevent moisture and unwanted bugs from entering your shed through here.

Parts (Step D11)
Foam Enclosures
(Several Pieces)

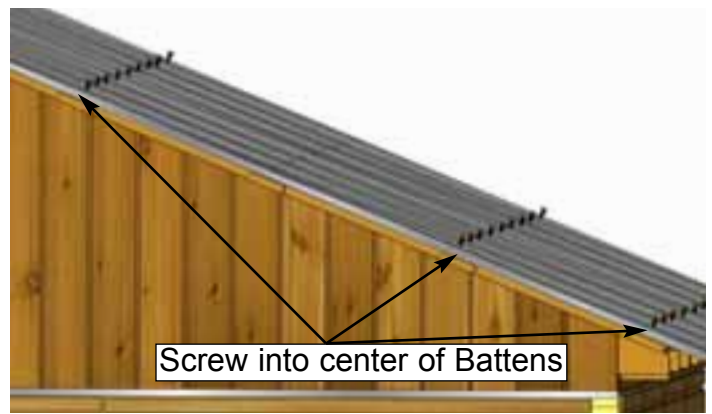

D12. To secure **Metal Roof Panels**, use an additional 27 - 1 1/2" **Metal Screws** and 1/4" **Nut Driver**, Secure **Metal Roof Panels** down to lower 4 rows of **Battens**. Leave the top row unsecured for now to secure **Ridge Cap** later in **Step D17**. Tighten screws in middle row that were partially secured in **Step D10**.



D13. Move to polygal side of roof and locate **Metal Roof Panels Short**. Space panels apart as per **Step D8** to match opposite side. **Metal Roof Panels Short** will overhang lowest **Batten** by approximately 2 3/4". Caulk seams between panels before fastening to **Battens**. **Important:** **Metal Roof Hangers** do not set the overhang on the short panel side. Use a helper in addition to the hanger brackets to help keep panels in place while caulking and before fastening.

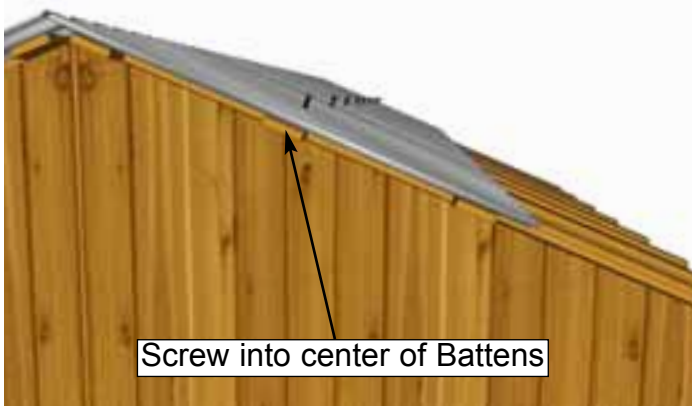

D14. Once seams have been caulked ensure the roof panels are overhanging the lowest **Batten** by approximately 2 3/4". When panels are positioned correctly secure panels to middle row of **Battens** with 9 - 1 1/2" **Metal Screws**. With middle row secured place **Foam Enclosures** between bottom of roof panels and lowest row of **Battens**.

Parts (Step D14)
Foam Enclosures
 (Several Pieces)

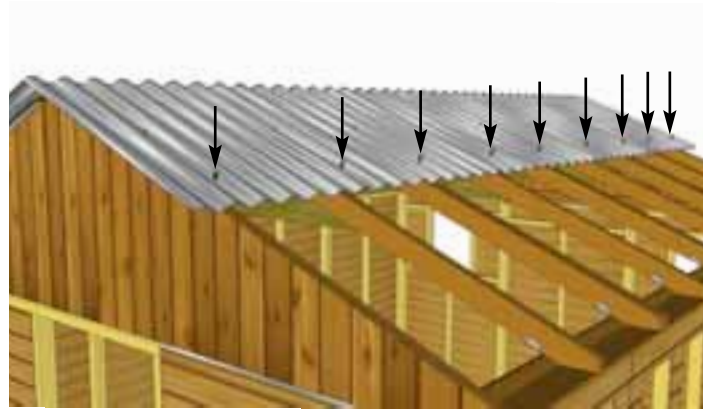

D15. Attach Metal Roof Panel to lowest row of Battens with 9 - 1 1/2" Metal Screws.



D16. Before attaching Metal Ridge Caps, place strips of Foam Enclosure near to top of shed. Enclosures will prevent moisture from coming in from the top. Complete both sides.

Parts (Step D16)
Foam Enclosures
(Several pcs)

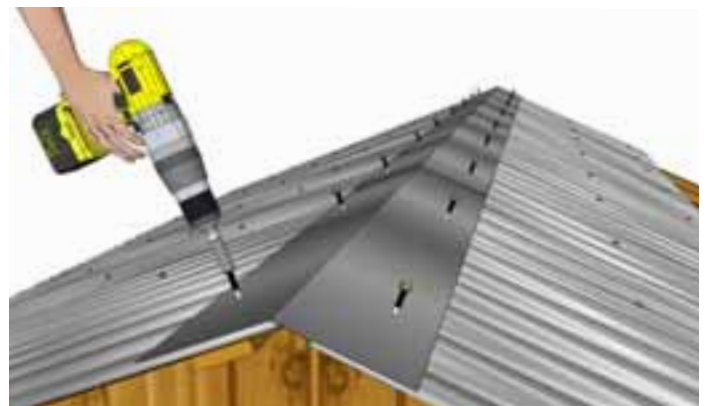

D17. Place Metal Ridge Caps on apex of roof. Evenly space from front to back. Caps will overlap each other. Overhang the cap approximately 1-2" past each end. When ridge cap is correctly positioned, secure with 18 - 1 1/2" Long Self Tapping Metal Screws using 1/4" nut driver (9/side). Screw into final Battens into center of Batten. Do not overtighten.

Hardware (Step D17)
1 1/2" - Metal Roof Screws
x 18 total

Parts (Step D17)
Metal Ridge Caps
(60" long) x 4

D. Roof Section - Plywood

**Exploded view of all parts necessary to complete the Roof Section.
Identify all parts prior to starting.**

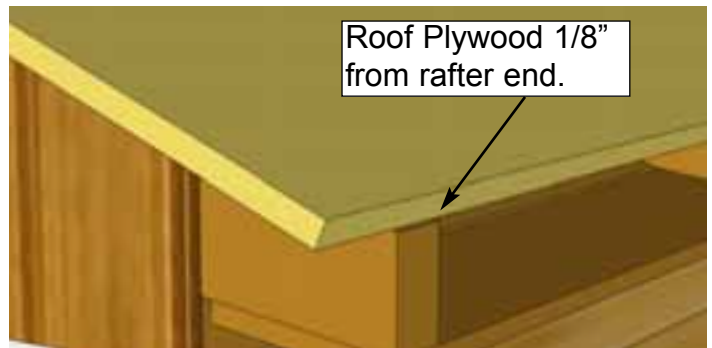
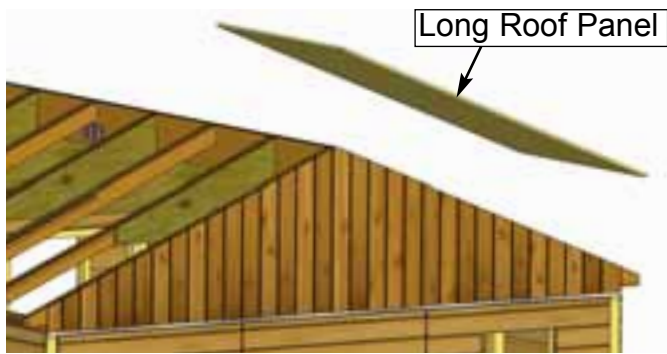
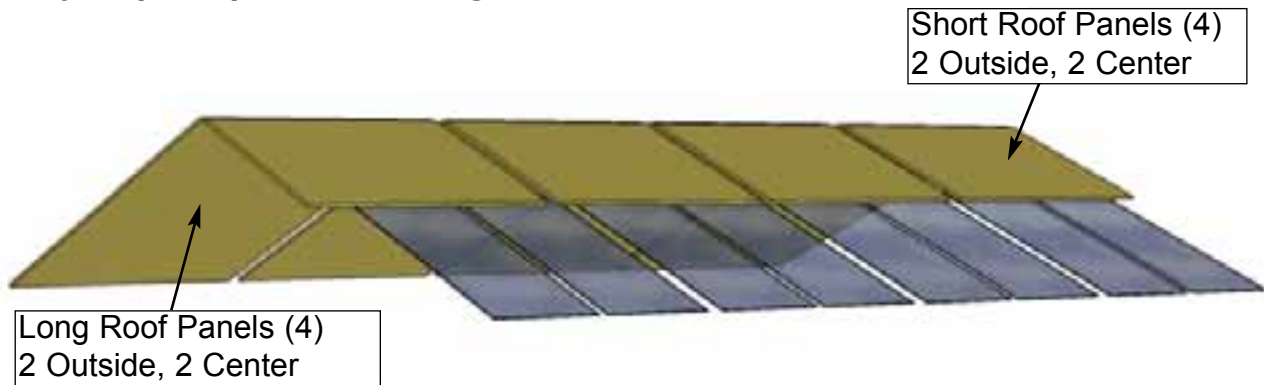

D1. Identify Roof Panels. There are 4 **Long Roof Panels** and 4 **Short Roof Panels**. Start on the long side of roof (side without polygal support cleats). Lift the long left panel onto roof such that the roof plywood is 1/8" from end of roof rafter.

Parts (Step D1 - D5)
Long L&R Roof Panels
 (5/8" x 48" x 81 1/2") x 2
Long Center Roof Panels
 (5/8" x 45 1/2" x 81 1/2") x 2

Hardware (Step D1 - D5)
1 1/4" Screws
 x 36 total

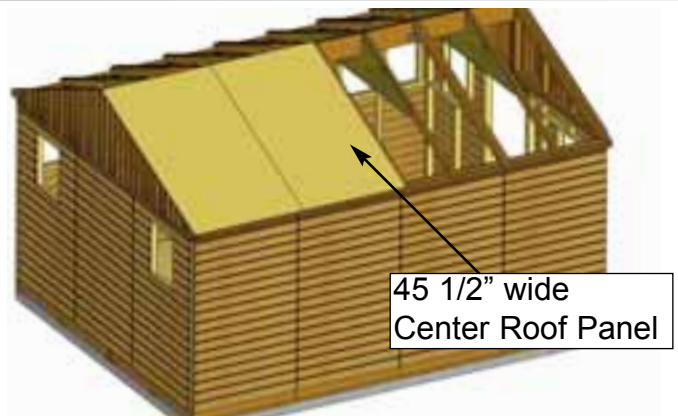
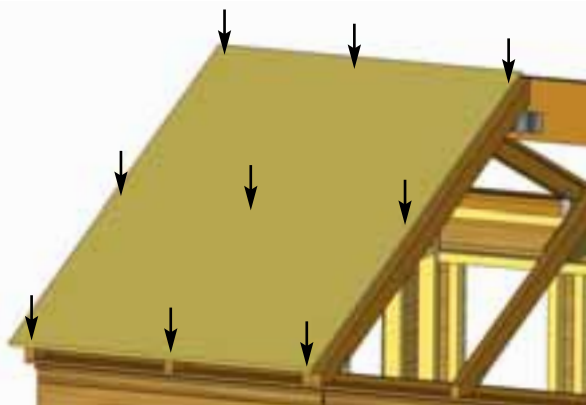

D2. Position Panel so roof plywood sits evenly on doubled up Rafters. Screw Panel to Rafters with 9 - 1 1/4" Screws. Lift up and place a **Long Center Roof Panel** on Rafters. Position evenly on Rafters.

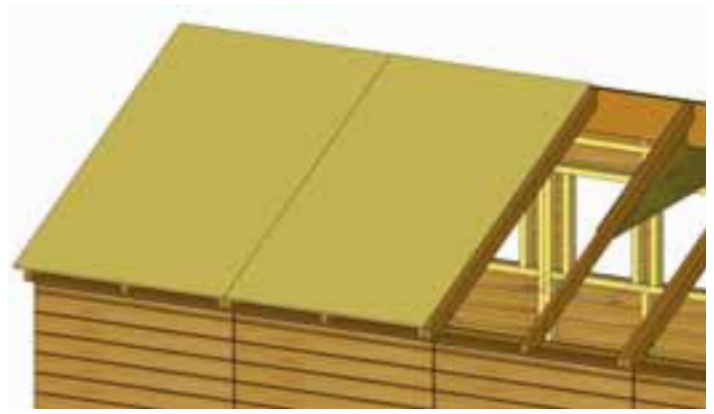
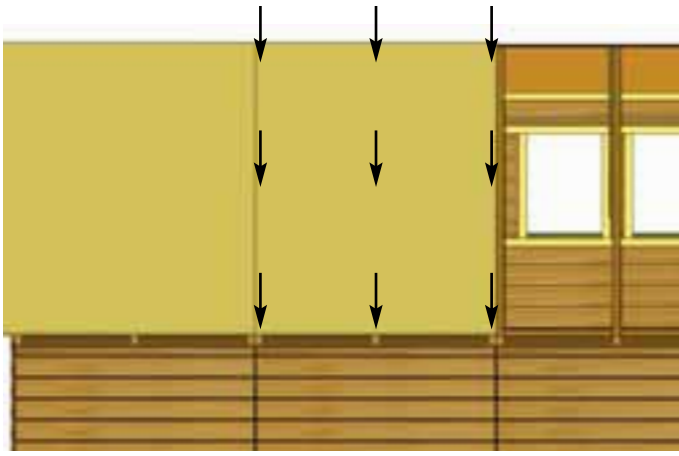

D3. Position **Center Roof Panel** so plywood is 1/8" from end of Rafters as per **Step D1**. From side-to-side, make sure Roof Panel is sitting equally on rafters. When positioned correctly, screw down with 9 - 1 1/4" Screws into Rafters.

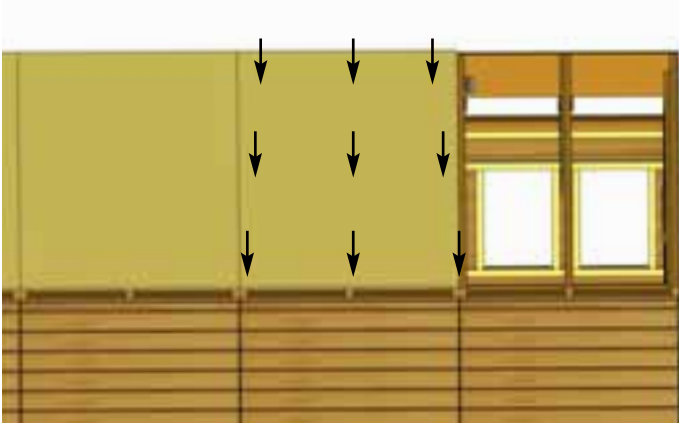

D4. Locate 2nd **Center Roof Panel** and position so plywood is 1/8" from end of Rafters as per **Step D1**. From side-to-side, make sure Roof Panel is sitting equally on rafters. When positioned correctly, screw down with 9 - 1 1/4" Screws into Rafters.

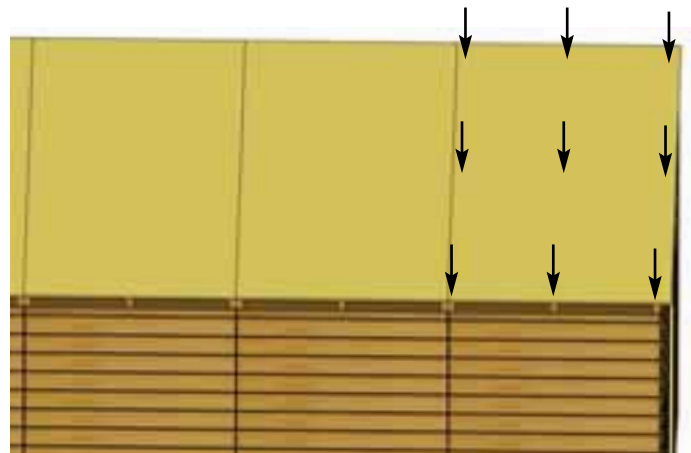

D5. Lift up and place remaining **Long Outside Roof Panel** on Rafters. With **Outside Roof Panel** centered on rafter and aligned as per **Steps D1 - D2**, screw panel down with 9 - 1 1/4" Screws.

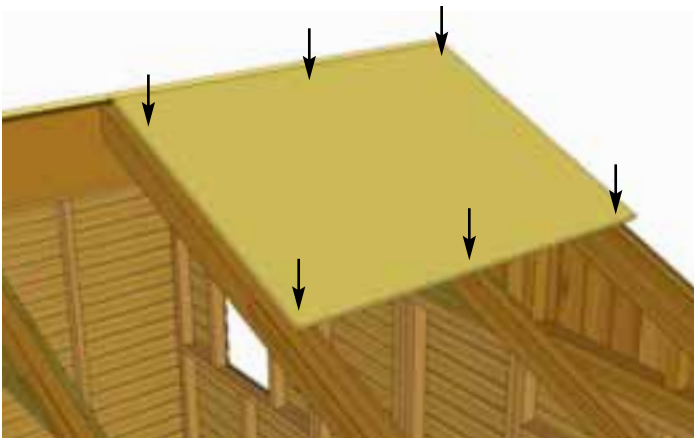

D6. Locate **Short Right Roof Panel**. Lift and place panel on polygal side of roof. Position **Short Right Roof Panel** equally on seam of doubled up Rafter as per **Step D2**. Align Roof Panel at top so even with long panel at peak. Reach through opening in Rafters to attach. When positioned correctly, screw down with **6 - 1 1/4" Screws** into Rafters as illustrated above. **Hint:** work from inside of shed to position and secure Polygal Side Roof Panels.

Parts (Step D6 - D7)
Short L&R Roof Panels
 (5/8" x 48" x 37 1/2") x 2
Short Center Roof Panels
 (5/8" x 45 1/2" x 37 1/2") x 2

Hardware (Step D6 - D7)

1 1/4" Screws
 x 24 total

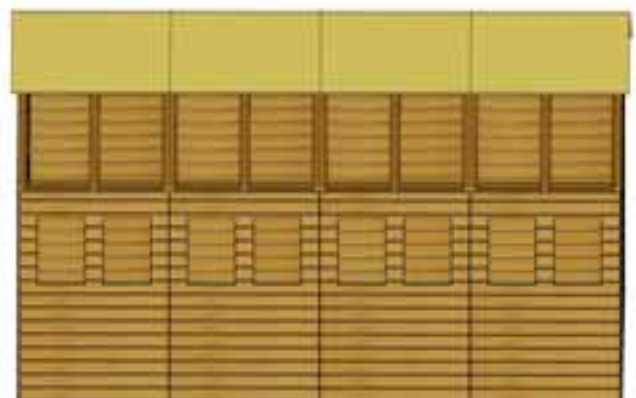

D7. Repeat **Steps D3 - D5** to attach remaining panels on short roof side. Align evenly at roof peak.

D. Polygal Roof Section - Cedar / Metal / Plywood

Exploded view of all parts necessary to complete the Roof Section. Identify all parts prior



Polygal Panels (8)

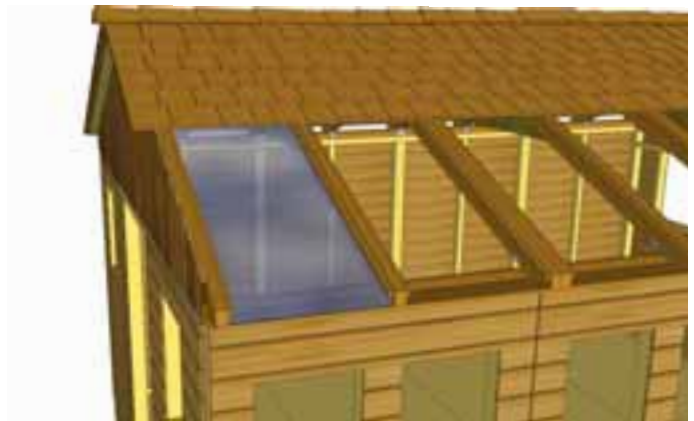
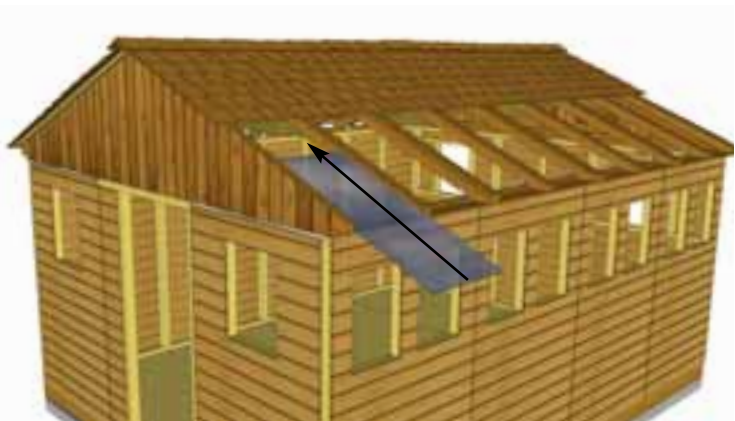

D1. Installation of 8 **Polygal Panels** is next. Start by removing protective plastic layer from each panel. Exterior/interior side of protective polygal film is printed on film, be sure to note the side and install accordingly. Slide panel up between **Rafters** so it rests on **Polygal Support Cleats**. From the inside, carefully slide end of **Polygal Panel** underneath roof. Position **Polygal Panel** equally between **Rafters**. **Polygal Panel** will overhang end of **Rafter** by 1/2".

Hardware (Steps D1 - D3)

1" Screws (Cedar Roof)
x 72 total

1" Screws (Metal Roof)
x 72 total

1" Screws (Plywood Roof)
x 48 total

3/4" Screws (Plywood Roof)
x 24 total

Parts (Steps D1 - D3)

Polygal Panels
(48" long) x 8

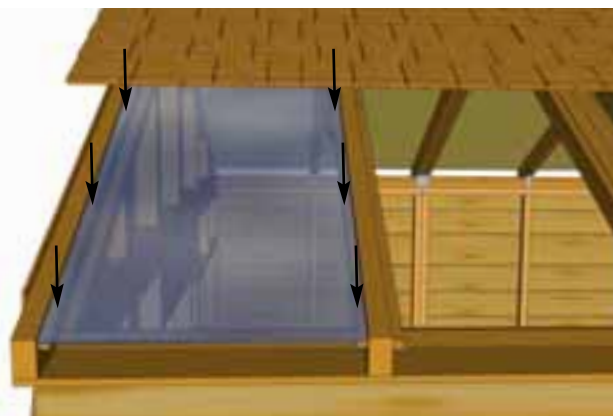

D2. Drill pilot holes with 1/8" bit through **Polygal Panel** and **Polygal Support Cleats**. Once aligned, with 6 - 1" **Screws**, secure panel to **Polygal Support Cleats**. Polygal is delicate, tighten screws a half turn at a time so screws are flush with top of **Polygal Panel**. For Cedar Roof, use 3 - 1" **Screws** to secure **Polygal Panel** to underside of Roof Plywood. For Metal Roof, use 3 - 1" screws to secure **Polygal Panel** to underside of Roof Batten. For Plywood Roof Use 3 - 3/4" **Screws** to secure **Polygal Panel** to underside of Roof Plywood



D3. Position and secure remaining **Polygal Panels** as per **Steps D1 - D2**. With a caulking gun, apply silicone to seal gaps between **Rafters** and **Polygal Panels**. Apply silicone down each side of **Rafter**. Use liberal amounts to properly seal.

E. Miscellaneous Section

Exploded view of all parts necessary to complete the Miscellaneous Section. Identify all parts prior to starting.

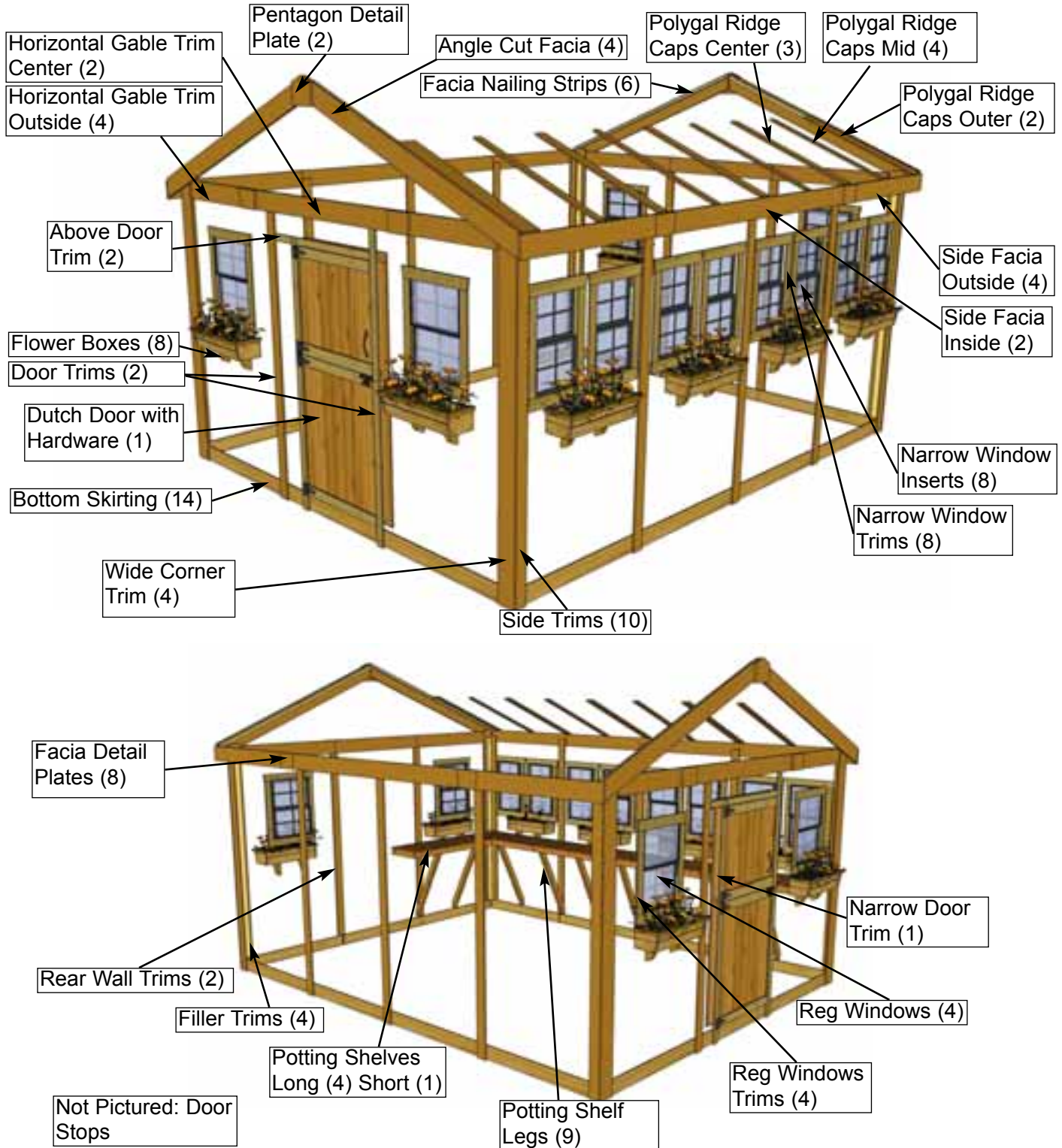

Expert Advice: When installing trim, sort pieces according to color and pieces that are most pleasing to the eye. Start with least visible side and use the least desirable pieces first. Install trim to most visible sides as your skill installing trim improves.

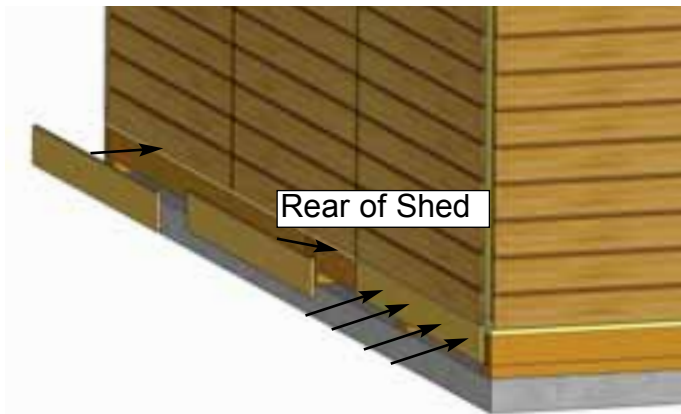

E1. Attach **Bottom Skirting - Bevel** around the base of the shed. Skirting will hide floor framing. Gaps on outside will be covered by trim pieces later. Start with front and rear skirting pieces first and attach with **4 - 1 1/2" Finishing Nails** per piece.

Hardware (Step E1)
1 1/2" - Finishing Nails
 x 56 total

Parts (Step E1)
Bottom Skirting-Bevel
 (1/2" x 4 1/2" x 45 1/4") x 14



E2. Check the wall seams for visible gaps prior to attaching filler trim and apply caulk where needed. Caulking gaps will help prevent moisture from entering and will help the longevity of your shed. Caulking is included to complete Polygal Windows only. Additional Caulking may be required for gaps.

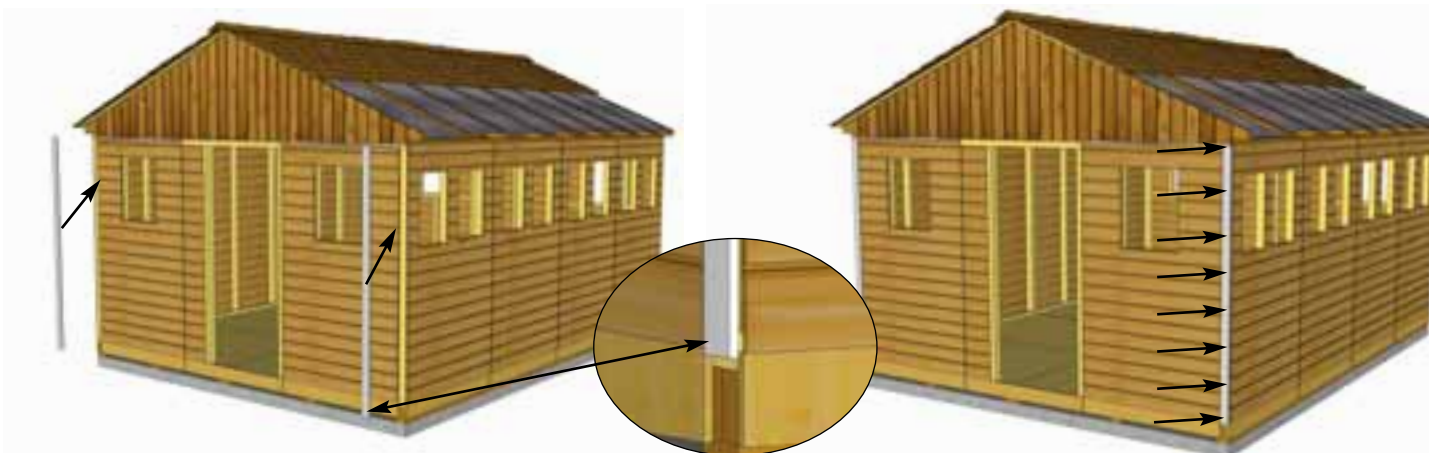

E3. Attach **Filler Trim** to front and rear walls in each corner. Attach with **8 - 1 1/2" Finishing Nails** per piece. Strips are positioned flush with bottom skirting.

Parts (Step E3)
Filler Trims
 (1/2" x 2 1/2" x 75") x 4

Hardware (Step E3)
1 1/2" Finishing Nails
 x 32 total

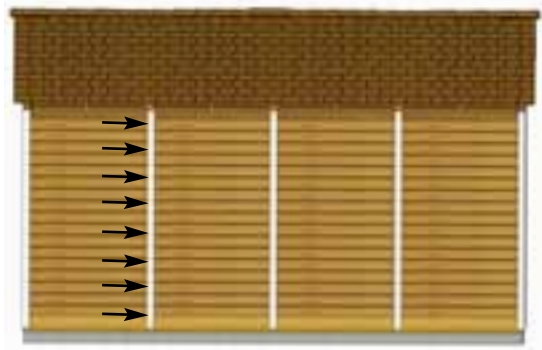

E4. Attach **Side Trims** to cover side wall seams and in the corners. align tight underneath **Soffit** and even with **Filler Trims**. Attach each with piece with 8 - 1 1/2" Finishing Nails. Note: Trim may sit slightly below **Bottom Skirting**.

Parts (Step E4)
Side Trims
 (1/2" x 2 1/2" x 80")
 x 10

Hardware (Step E4)
1 1/2" Finishing Nails
 x 80 total

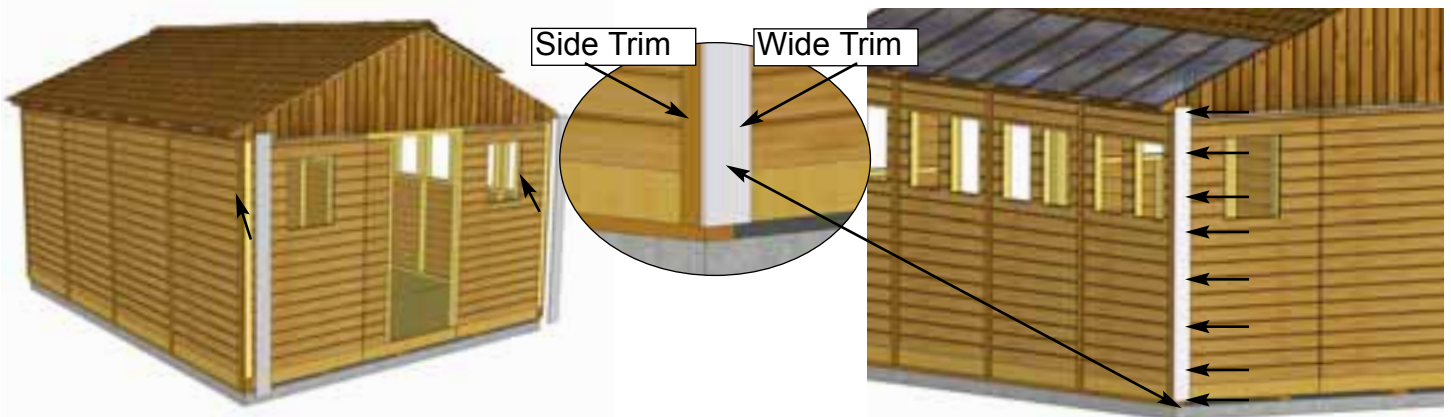

E5. Attach **Wide Corner Trims** over **Filler Trims**. Wide Trim will cap Side Trims. Attach with 8 - 1 1/2" Finishing Nails per piece.

Parts (Step E5)
Wide Corner Trims
 (1/2" x 5 1/2" x 82") x 4

Hardware (Step E5)
1 1/2" Finishing Nails
 x 32 total



E6. Attach **Rear Wall Trims**. to rear of shed. Use 8 - 1 1/2" Finishing Nails per piece.

Parts (Step E6)
Rear Wall Trims
 (1/2" x 2 1/2" x 78 1/2") x 2

Hardware (Step E6)
1 1/2" Finishing Nails
 x 16 total



Vertical position determined by Horizontal Gable trims.

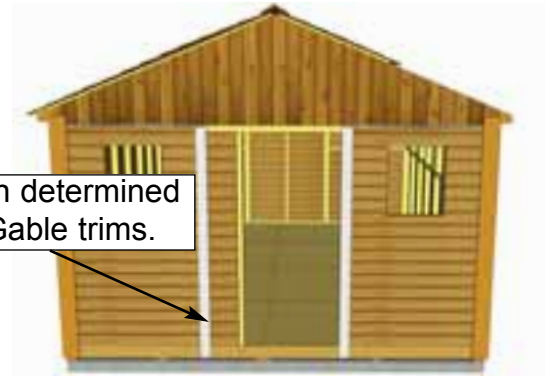

E7. Position **Narrow Door Trim** on left side of door opening and one **Door Trim** on right side of door. Right side will sit flush with **Door Jamb**. Left side will sit flush on edge of **Narrow Wall**. Do a dry run with the **Horizontal Gable Trim** from **Step E11** to determine vertical location of right trim, left trim will sit below **Drip Edge** installed in **Step E11**. Attach with **8 - 1 1/2" Finishing Nails** per piece.

Hardware (Step E7)
1 1/2" - Finishing Nails
 x 16 total

Parts (Step E7)
Narrow Door Trim
 (1/2" x 2 1/2" x 78 1/2") x 1
Door Trim
 (1/2" x 3 1/2" x 78 1/2") x 1



E8. Attach **Door Trim** to cover seam between **Window Wall Panel** and **Narrow Wall Panel**. Use **8 - 1 1/2" Finishing Nails**.

Parts (Step E8)
Left Door Trim
 (1/2" x 3 1/2" x 78 1/2") x 1

Hardware (Step E8)
1 1/2" Finishing Nails
 x 8 total

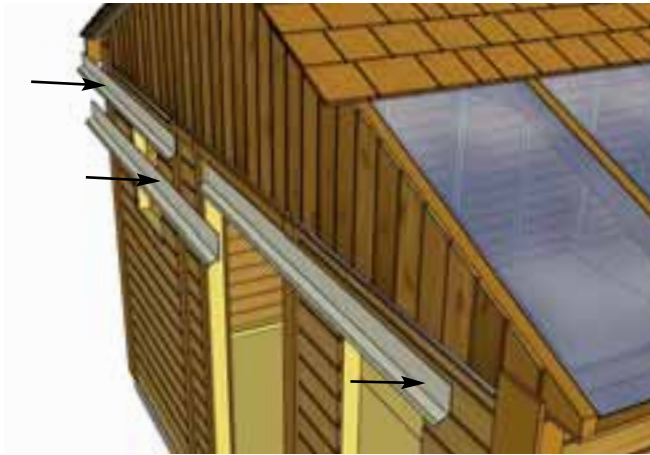

E9. Locate Drip Edge (3). With pieces overlapping attach to Door Header with 8 - 1 1/2" Finishing Nails. Note: Drip edge pieces should be overlapping each other Door Trims before attaching drip edge to confirm proper spacing.

Part (Step E9)
Drip Edge
(60") x 3

Hardware (Step E9)
N1 - 1 1/2" Finishing
Nails
x 24 total

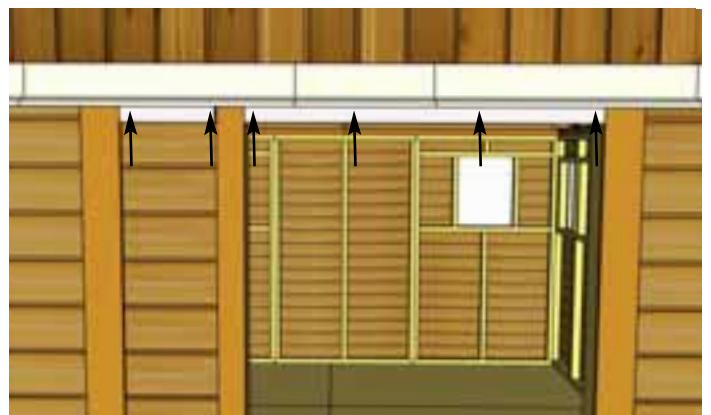

E10. Attach Horizontal Door Trims above door and below Drip Edge. Attach with 2 - 1 1/2" Finishing Nails for short piece and 4 - 1 1/2" Finishing Nails for longer piece.

Parts (Step E10)
Horizontal Door Trim
(1/2" x 2 1/2" x 8") x 1
(1/2" x 2 1/2" x 32") x 1

Hardware (Step E10)
1 1/2" Finishing Nails
x 6 total



E11. Locate **Horizontal Gable Trims** for both front and rear of shed. Position equally over Gable and Wall seam. Attach each piece with **6 - 1 1/2" Finishing Nails**.

Parts (Step E11)
Horizontal Gable Trims
 (1/2" x 4 1/2" x 42") x 2
 (1/2" x 4 1/2" x 45 1/4") x 4

Hardware (Step E11)
1 1/2" Finishing Nails
 x 36 total

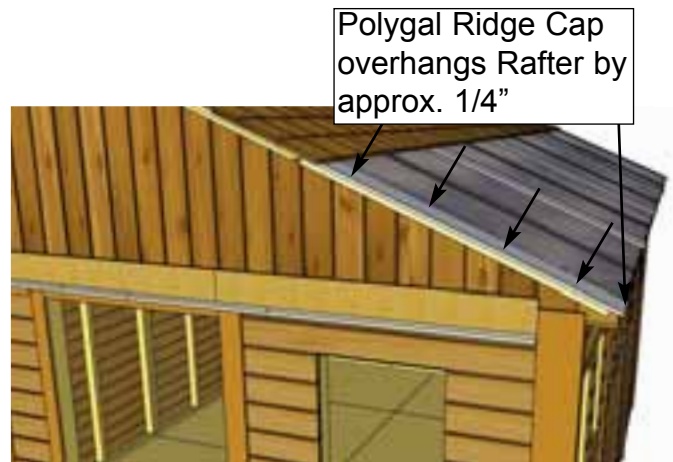
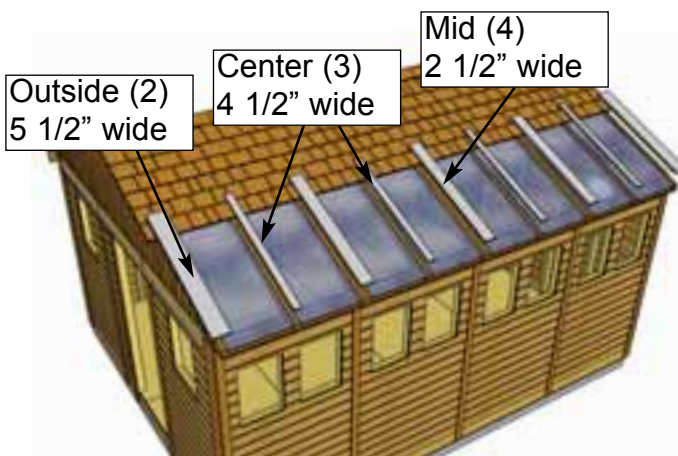

E12. Locate all **Polygal Ridge Caps** (4 Mid, 2 Outside, and 3 Center). Starting from the outsides, position both 5 1/2" wide caps so the long edge with pre-attached fascia nailing strip is below cedar roof panel. When correctly aligned, attach Caps to center of outside Rafter with **4 - 1 1/2" Finishing Nails**. Use a straight edge to align Cap with Cedar Roof Panels. See above.

Parts (Step E12 - E14)
Outside Polygal Ridge Caps
 (1/2" x 5 1/2" x 44") x 2
Center Polygal Ridge Caps
 (1/2" x 4 1/2" x 44") x 3
Mid Polygal Ridge Caps
 (1/2" x 2 1/2" x 44") x 4

Hardware (Step E13 - E15)
1 1/2" Finishing Nails
 x 36 total

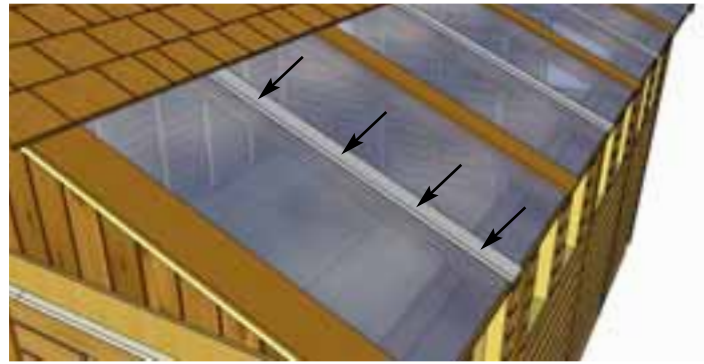

E13. Position and attach **Mid Ridge Caps** evenly spaced on single **Rafters**. Align top to bottom as per **Step E12**. Secure each piece with **4 1 1/2" Finishing Nails**.

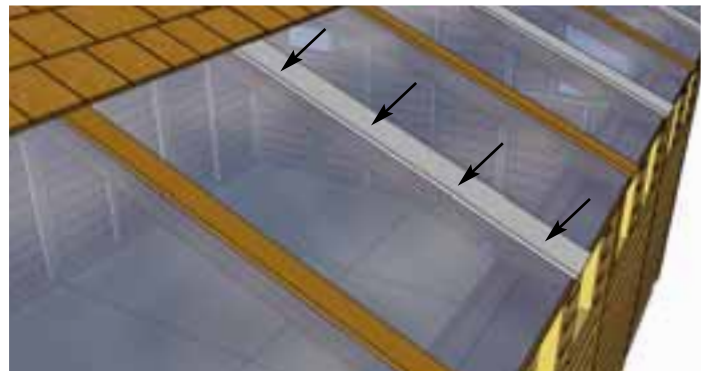

E14. Position and attach **Center Ridge Caps** evenly spaced on double **Rafters**. Align top to bottom as per **Step E13**. Secure each piece with **4 - 1 1/2" Finishing Nails**.



E15. Attach **Facia Cleat Short** centered on underside of Polygal Side Battens, flush to edge. Attach **Facia Cleat Long** to underside of **Battens** on Non-Polygal side, flush edge to edge. Repeat this step on rear of shed. Fasten each cleat with **3 - 1 1/4" Screws** per piece.

Parts
Facia Cleat Short
 (3/4" x 1 1/2" x 36 1/2") x 2
Facia Cleat Long
 (3/4" x 1 1/2" x 40") x 4

Hardware
1 1/4" Screws
 x 18 total

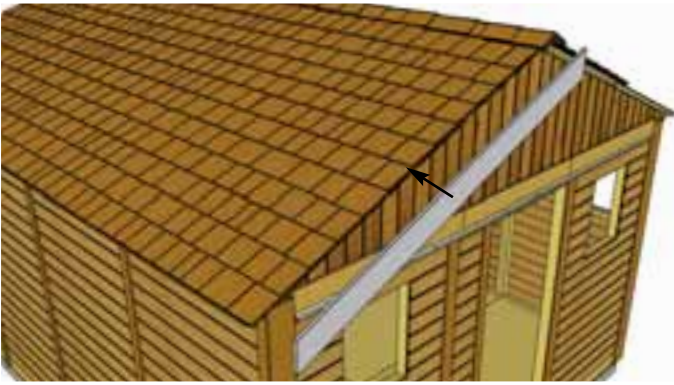

E16. Attach **Front and Rear Facia (angle cut on ends)**, to **Facia Cleats** on **Non-Polygal Roof side**, with **10 - 1 1/2" Finishing Nails** per piece. Line up **Facia** so **Facia ends** line up with **Rafter ends**.

Hardware (Step E16, E18)
1 1/2" Finishing Nails
 x 40 total

Parts (Step E16, E18)
F&R Facia (angled ends)
 (3/4" x 5 1/2" x 81 1/4") x 4



E17. Attach **Side Facia** to roof **Rafter ends**. There are **3 Side Facia** pieces per side. Secure with **8 - 1 1/2" Finishing Nails** per piece. **Side Facia** will cap **Front and Rear Facia**.

Parts (Step E17, E19)
Side Facia
 (3/4" x 5 1/2" x 49 1/2") x 4
 (3/4" x 5 1/2" x 89 1/4") x 2

Hardware (Step E17, E19)
1 1/2" Finishing Nails
 x 48 total

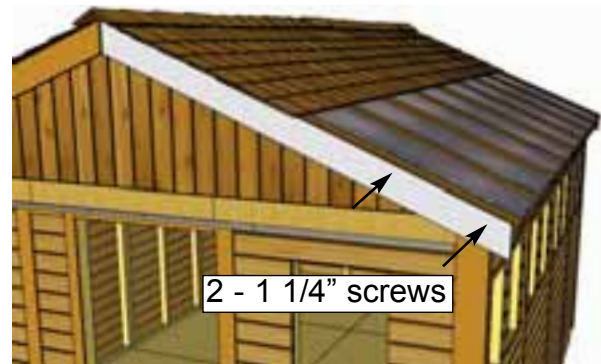

E18. Attach remaining **Front & Rear Facia** pieces to **Facia Cleats** under **Roof Battens** and **Outside Ridge Cap** edge with **10 - 1 1/2" Finishing Nails** and **2 - 1 1/4" screws**. Use screws where **Outside Ridge Cap** and **Facia** meet. Once again, line up **Facia** so it is aligned with **Rafter ends**. Do a **dry run** with **Front, Rear and Side Facia** to confirm positioning prior to attaching.

Hardware (Step E18)
1 1/4" Screws
 x 4 total

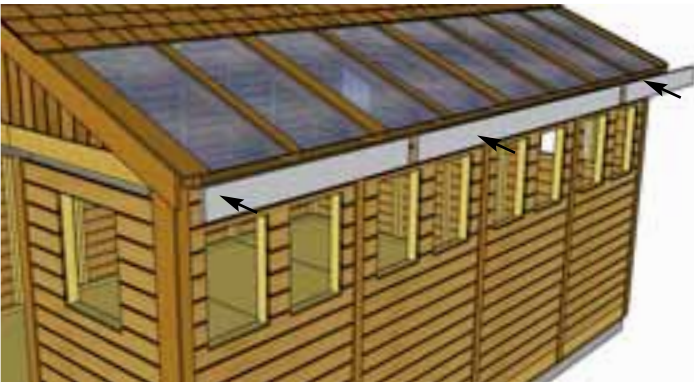

E19. Attach remaining Side Fascia to roof Rafter ends as per Step E17. Side Fascia fits underneath Polygal Panels and Polygal Ridge Caps.

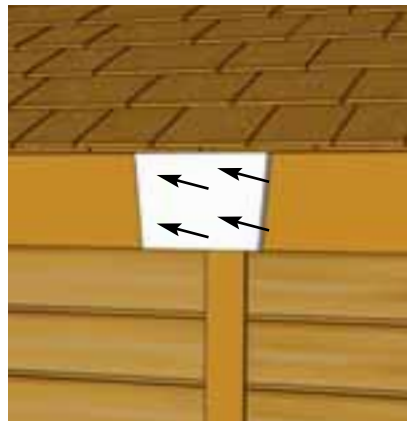

E20. Attach Fascia Detail Plates and Pentagon Detail Plates to cover seams where Fascia and Trim pieces come together. Secure each with 4 - 1 1/2" Finishing Nails.

Parts (Step E20)
Pentagon Detail Plates
 (9 1/2" x 7 1/2") x 2
Fascia Detail Plates
 (8" x 5 1/2") x 4

Parts (Step E20)
Gable Detail Plates
 (8" x 4 1/2") x 4
Hardware (Step E20)
1 1/2" Finishing Nails
 x 36 total

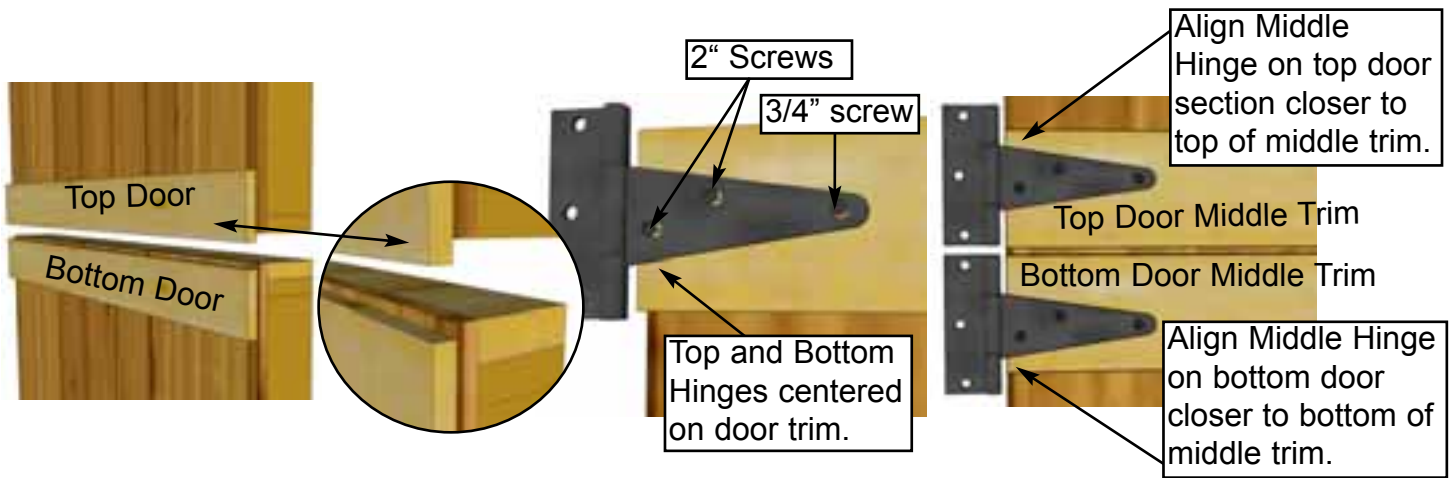

E21. Attach Door Hinges to **Top** and **Bottom Dutch Door** sections. Top Door section has middle trim overhanging door at bottom while bottom door section has middle trim recessed slightly. Top and Bottom Hinges should be centered on door trim. Align the middle hinge for the top door section closer to the top of the middle door trim. Align the middle hinge for the bottom door section closer to the bottom of the middle door trim. Middle hinges should not overlap. Position middle hinges accordingly. Use **2" & 3/4" Black Headed Screws** as shown above.

Parts (Step E21)
Dutch Door
 (Top) x 1
 (Bottom) x 1

Hardware (Step E21)
2" Black Screws
 x 8 total
3/4" Black Screws
 x 4 total
Black T Hinge
 x 4 total

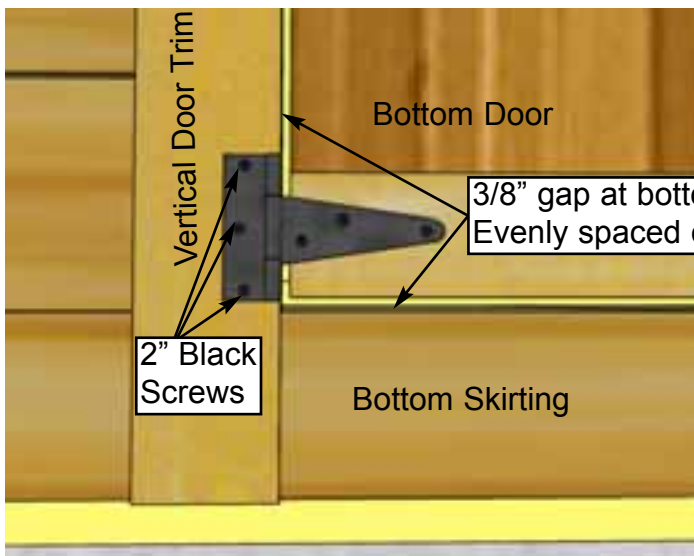

E22. Place **Bottom Dutch Door** panel into position. Gap $3/8$ " on bottom, evenly space on sides, and attach hinge to doorway seam trim with 3 - **2" Black Headed Screws**. Use shim to help keep the door evenly spaced on bottom. One of the **Shim Shingles** can be used.

Parts (Step E22)
Dutch Door
 (Bottom) x 1
Shim Shingles

Hardware (Step E22)
2" Black Screws
 x 6 total

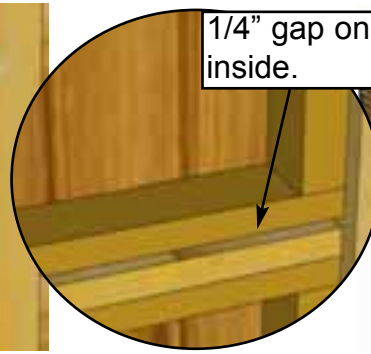
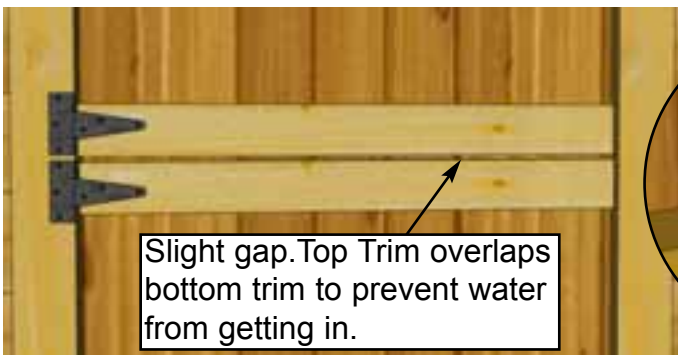

E23. Place the **Top Dutch Door** panel into place and gap top and bottom trims on the outside about 1/8" apart/ On the inside, horizontal door frames should be about 1/4" apart. Use a shim once again to help you. Attach hinges to trim with **2" Black Headed Screws** provided.

Parts (Step E23)
Dutch Door
 (Top) x 1
 (Bottom) x 1
Shim Shingles

Hardware (Step E23)
2" Black Screws
 x 12 total



E24. Attach **Door Handle**, **Exterior Barrel Bolt** and **Interior Barrel Bolt** to door. **Handle** is positioned on top door, **Barrel Bolt** on bottom door, and **Interior Barrel Bolt** (silver) on top door stud. Attach **Black Barrel Bolt** as illustrated above with 4 - **3/4" Black Screws**. Note how female part of Barrel Bolt is positioned higher than male part. Do a dry run first to position **Barrel Bolt** correctly. Important: Drill pilot holes with 1/8" drill bit prior to securing to prevent wood from splitting.

Hardware (Step E24)
3/4" Black Screws
 x 16 total
3/4" Silver Screws x 6 total
Black Handle x1
Black Barrel Bolt x1
Silver Barrel Bolt x1

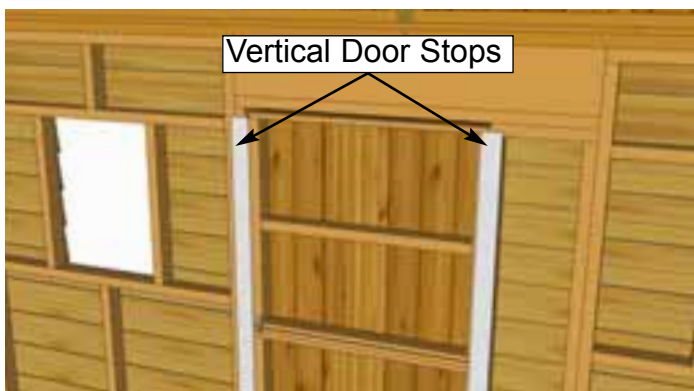

E25. Attach **Interior Vertical** and **Horizontal Door Stops** to door framing from inside of shed. Use 4 - **2" screws** to secure each stop. Stops should overlap door by approx. 1/2".

Parts (Step E25)
Door Stops
 (1/2" x 2 1/2" x 72") x 2
 (1/2" x 2 1/2" x 36") x 1

Hardware (Step E25)
2" Screws
 x 12 total

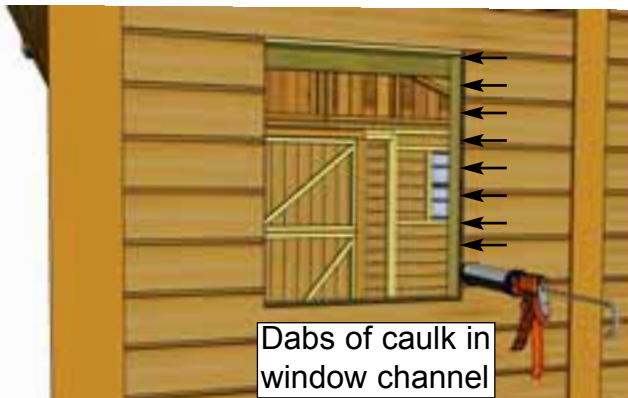

E26. Locate **Window Inserts**. There are two type **Regular** and **Narrow** (for double window walls). Before installing, dab caulk in siding channel on both sides and across top of window opening. This will prevent water from getting in behind window. Position window in cavity and secure with **8 - 1 1/4" Screws**. **Window trims** will be installed next to hide caulking.

Parts (Step E26)
Regular Window Inserts
 x 4
Narrow Window Inserts
 x 8

Hardware (Step E27)
1 1/4" Screws
 x 96 total



E27. Position **Window Trim** around window doing a dry run first and attach with **4 - 1 1/2" Finishing Nails** per piece. There are two Trim Kits (Regular/Narrow). The regular window kit = 1" x 24 1/16"=top (angle cut on ends), 3" x 23" = Sides and Bottom. Narrow window kit = 1" x 19 7/8" Top, 2" x 21 7/16" Sides, 1" x 18 3/4" Bottom. Window trim has a small dado on reverse face. Outside flange of window will roughly sit in the dado to give a better fit.

Hardware (Step E27)
1 1/2" Finishing Nails
 x 192 total

Parts (Step E27)
Regular Window Trim
 x 4
Narrow Window Trim
 x 8



E28. Assemble **Flower Box Kits** with Assembly Instructions included on Page 60. Position completed Flower Box below bottom of window trim and secure with **2 - 2 1/2" screws**. Screw from inside of box into the center wall stud. Attach second screw 2" underneath first screw and once again into the wall stud. Install Flower Box Kits underneath each window/double-window.

Hardware (Step E28)

2 1/2" Screws
x 16 total

Parts (Step E28)

Flower Box Kits
x 8



E29. Locate **Long Potting Shelf** and 2 **Potting Shelf Legs**. Position shelf in corner tight against wall framing. While supporting the shelf, attach shelf with **2 - 2 1/2" Screws** to wall frame. Place leg underneath shelf and attach to inside shelf framing and wall framing as illustrated above with **2 - 2 1/2" Screws**.

Parts (Step E29)

Long Potting Shelves
(16" x 45") x 4
Short Potting Shelf
(16" x 41") x 1
Potting Shelf Legs
(1 1/2" x 2 1/2" x 38") x 9

Hardware (Step E29)

2 1/2" Screws
x 38 total



E30. Place next **Potting Shelf** against wall framing and end of Long Shelf framing. Attach with 2 - 2 1/2" Screws as per **Step E29** to first shelf and wall framing. Use a level to confirm shelving is square and level. Attach legs as previously illustrated. Screw to wall stud and up into the underside of shelf framing. Continue attaching shelves along wall as per **Steps E29** . Short Potting Shelf goes in the corner and only receives one leg.

Outdoor Living Today Flower Box Assembly Instructions

Parts Lists:

A - Base, Rear & Front Box Frames (3pcs)	$3/4" \times 5 1/2" \times 23"$
B - End Cap Frames (2pcs)	$3/4" \times 5 1/2" \times 7" / 8"$
C - Front Trim (1 pc)	$3/4" \times 1 1/2" \times 26"$
D - Side Trims (2 pc)	$3/4" \times 1 1/2" \times 8 3/4"$
E - Brackets (2 pc)	$1 1/2" \times 5 1/2" \times 5 1/2"$
F - 1 1/4" Screws (15 pc)	(15 pc)
G - 1 1/2" Nails (10 pc)	(10 pc)

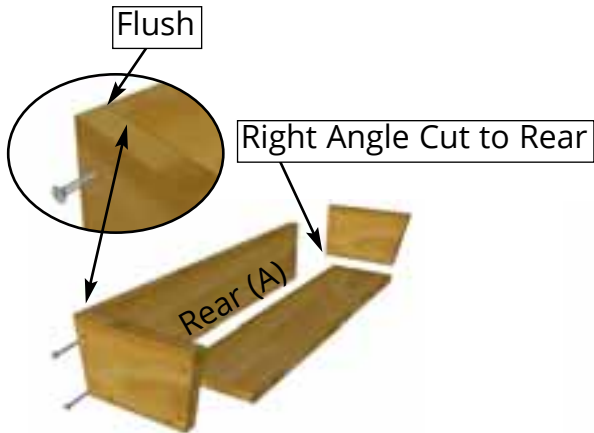
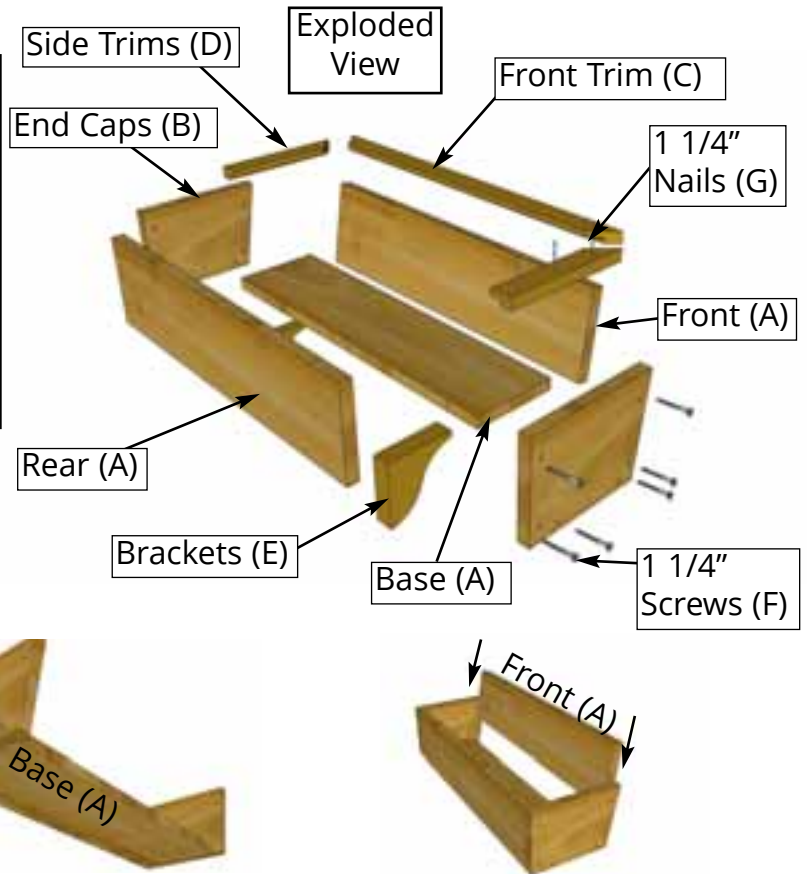

1. On a table position Rear Box and End Cap Frames together so flush at top. Fasten together with 2 - 1 1/4" screws. Place Base Frame tight against Rear and End Cap and flush at bottom. Secure with 2 - 1 1/4" screws. Complete attachment of remaining End Cap Frame. Slide Front Frame between End Caps.

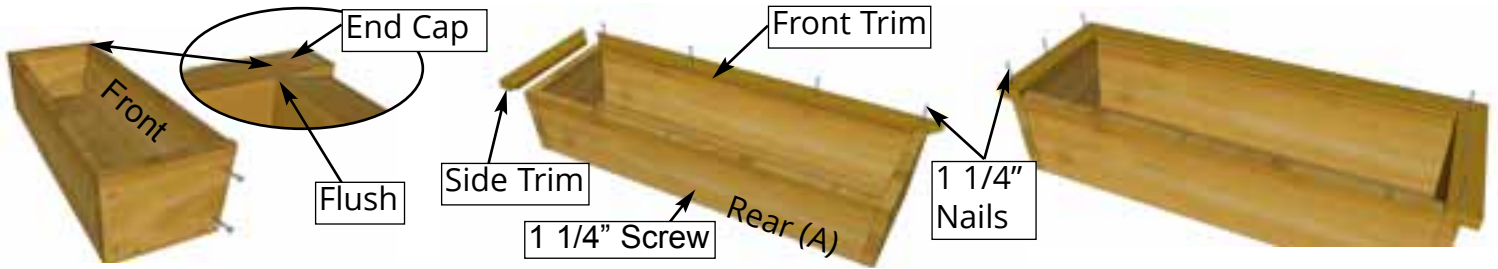

2. Position Front Frame Piece flush with End Cap. Attach both ends with 2 - 1 1/4" screws. Pilot hole Rear Box Frame near bottom center and secure to Base edge with 1 - 1 1/4" screw. Evenly position Front Trim (mitre cut on end and dado cut on inside bottom) tight against front frame and nail down with 4 - 1 1/4" nails. Position Side Trims as per Front and secure with 3 - 1 1/4" nails per side.

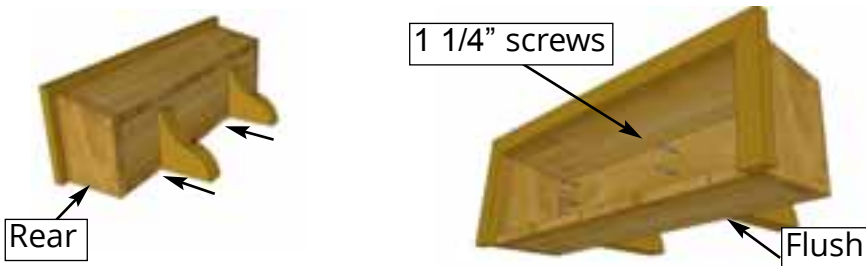

3. On a flat surface, flip Flower Box on it's rear face. Evenly space Brackets and secure through Base Frame and into the Brackets with 2 - 1 1/4" screws per Bracket. Position completed Flower Box beneath window trim and screw from inside of box into the center wall stud with 2 - 2" screws. (2" screws supplied with Base Kit.)



Outdoor Living Today

Congratulations on
assembling your
12x16 Sunshed!



Note: Our Sheds are shipped as an unfinished product. If exposed to the elements, the lumber will weather to a silvery-gray color. If you prefer to keep the lumber looking closer to the original color, we suggest that you treat the wood with a good oil base wood stain. You may also wish to paint your new shed rather than stain it. In both cases we recommend that you consult with a paint and stain dealer in your area for their recommendations.

We hope your experience constructing our **12x16 Sunshed** has been both positive and rewarding. We value your feedback and would like to hear back from you on how well we are doing in the following areas:

1. Customer Service
2. On Time Shipping
3. Motor Freight Delivery
4. Quality of Materials
5. Assembly Manual
6. Overall Satisfaction



The materials contained in this Assembly Manual may be downloaded or copied provided that ALL copies retain the copyright and any other proprietary notices contained on the materials. No material may be modified, edited or taken out of context such that its use creates a false or misleading statement or impression as to the positions, statements or actions.

Please call, write or email us at:

Canadian Address
9393 287th Street
Maple Ridge, British Columbia
Canada V2W 1L1

United States Address
P.O. Box 96
Sumas, Washington
USA 98295

Toll Line: 1.888.658.1658

Fax: 1.604.462.5333

sales@outdoorlivingtoday.com