

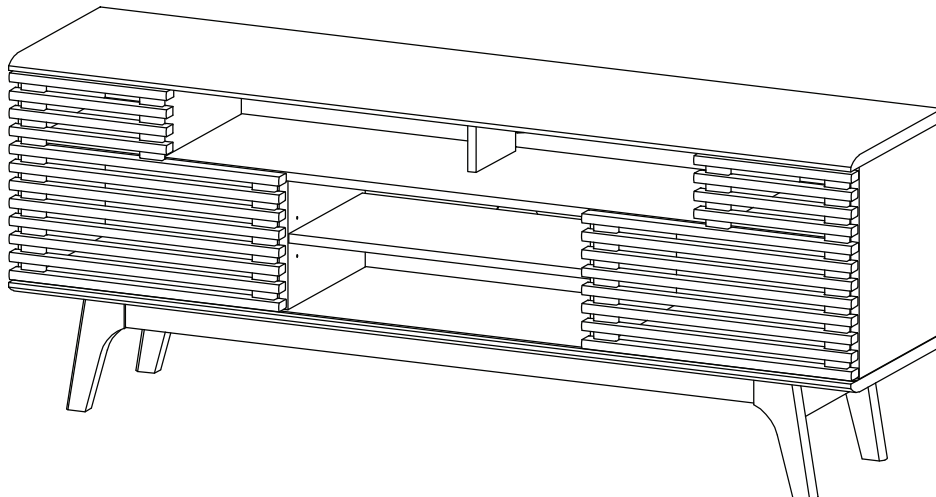

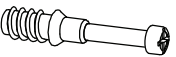







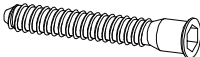

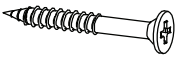
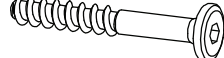



Before you start, here are some helpful advice:

1. We suggest you spend a short time reading through this leaflet and then follow the simple step-by-step instructions.
2. Owing to the size and weight of the TV Stand, we recommend that it is assembled by two adults, on a carpeted or padded area, in the room that it is intended for. Approximate assembly time: 70 minutes.
3. Please do not use any tools other than those provided or recommended in these instructions.
4. Please do not throw away any of the packaging or instructions until you have checked all the components and hardware and the furniture is fully assembled.
5. Assemble all components loosely until advised to tighten. Depending on use, it may be necessary to tighten the components from time to time, so please save the tools that have been provided.
6. Please keep all pieces out of reach of children.



### Hardware :

A) Cambolt/Metal  ∅ 6 x 35 mm x 17	B) CamLock/Metal  ∅ 15 mm x 17	C) Dowel/Wood  ∅ 8 x 30 mm x 50	D) Screw/Metal  M 7 x 50 mm x 9	E) Hex/Allen Key/Metal  L 4 x 1
F) Screw/Metal  5.5 x 35 mm x 4	G) Screw/Metal  M 6.4 x 53 mm x 4	H) Floor Protector/Sponge/Felt  25 x 25 x 2 mm x 4	I) Buffer/Rubber  ∅ 8 mm x 1	J) Screw/Metal  M 6 x 12.5 mm x 14
K) Anti-Deflection Bar/Metal  1200 mm x 1	L) Screw Cup/Plastic  ∅ 15 mm x 9	M) Shelf Pin/Metal  ∅ 5 x 15 mm x 4	N) Wedge/Plastic  9 x 14 x 10 mm x 18	O) Screw/Metal  M 3.5 x 15.5 mm x 18
P) Stoper/Plastic  42 x 14 x 8 mm x 2	Q) Pin Sliding Top/Plastic  ∅ 8 x 19 mm x 4	R) Pin Sliding Bottom/Plastic  ∅ 8 x 16 mm x 4	S)  Screwdriver (Not Include) x 1	

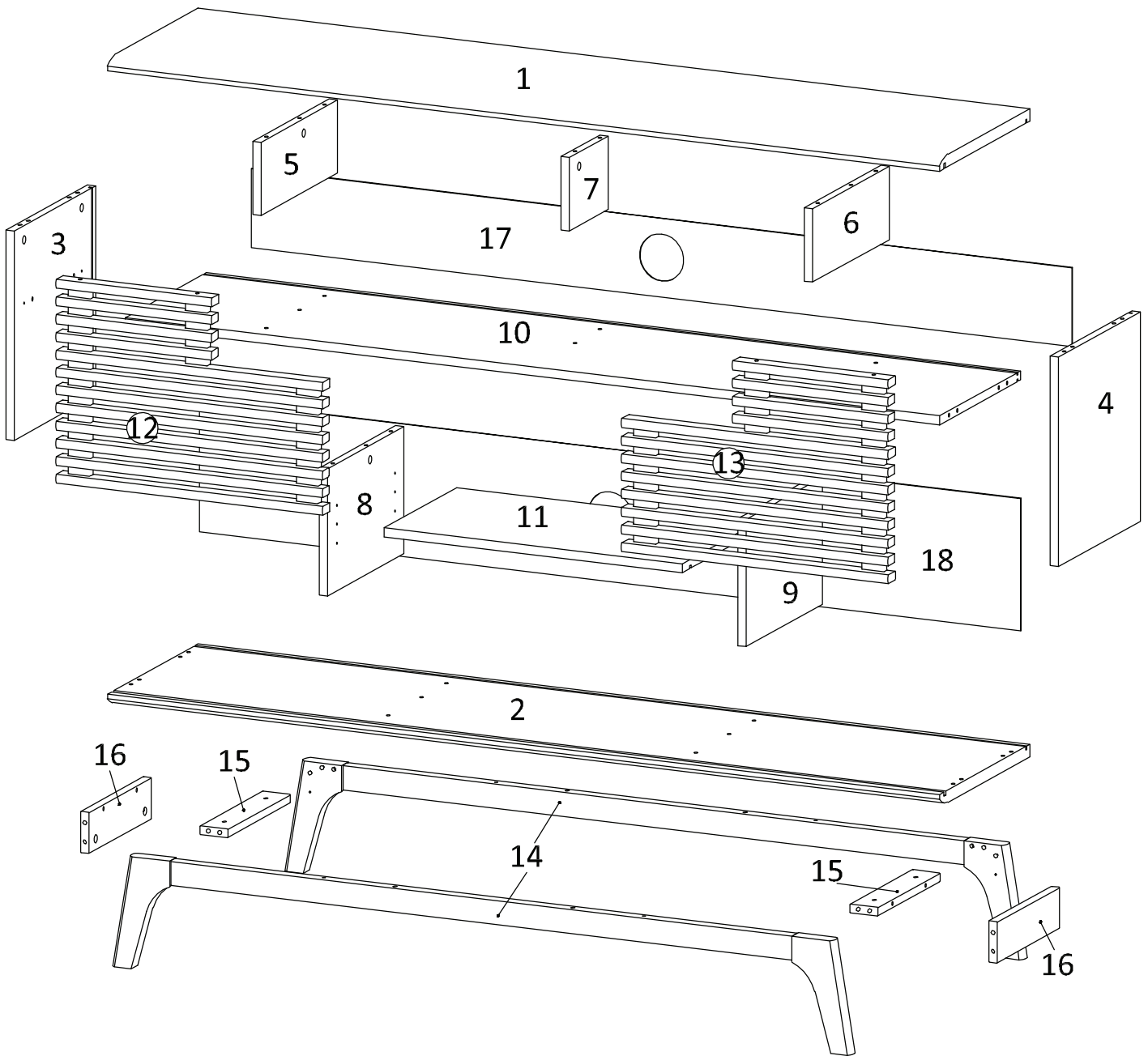

**Components:**

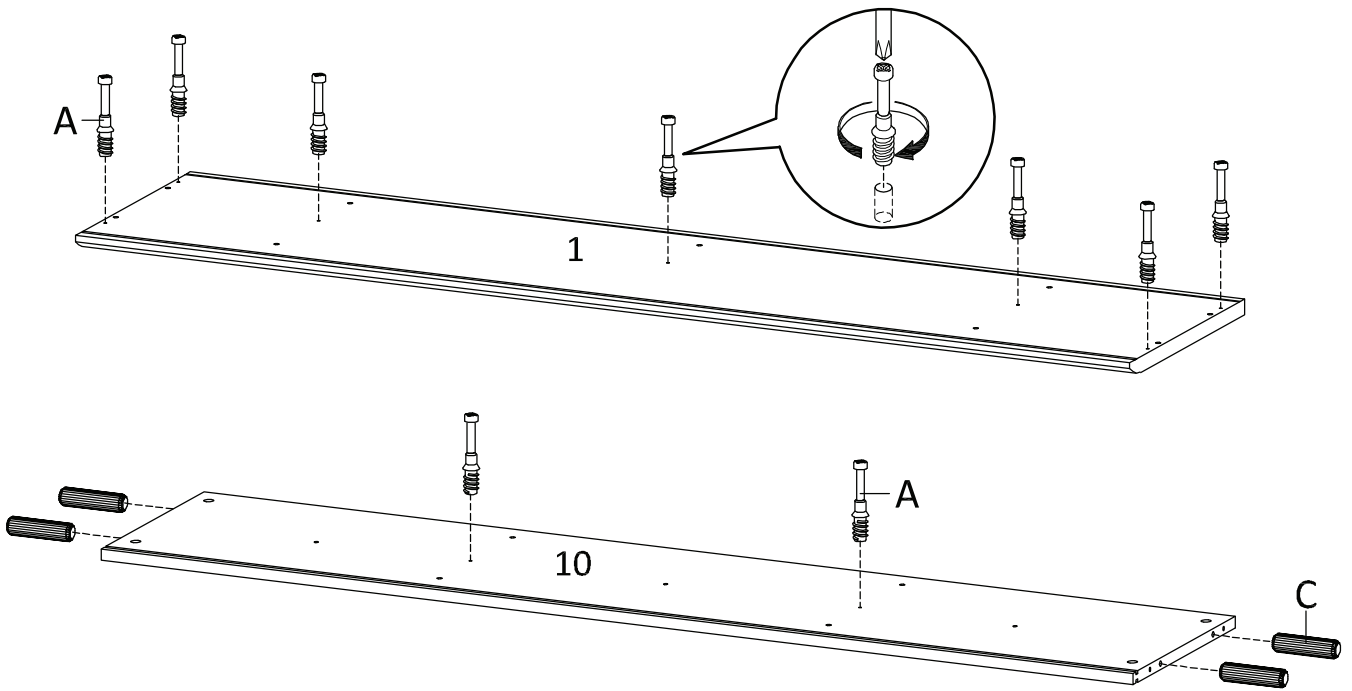

1	Top Board	x1	2	Bottom Board	x1	3	Side Board Left	x1	4	Side Board Right	x1
5	Center Board 1	x1	6	Center Board 2	x1	7	Center Board 3	x1	8	Center Board 4	x1
9	Center Board 5	x1	10	Fixed Shelf	x1	11	Adjustable Shelf	x1	12	Frame Door Left	x1
13	Frame Door Right	x1	14	Assembly Leg	x2	15	Support 1	x2	16	Support 2	x2
17	Back Board 1	x1	18	Back Board 2	x1						

**STEP 1:**

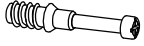

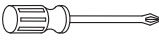

		
Ax9	Cx4	Sx1

Hardware required.  
Screwdriver not included

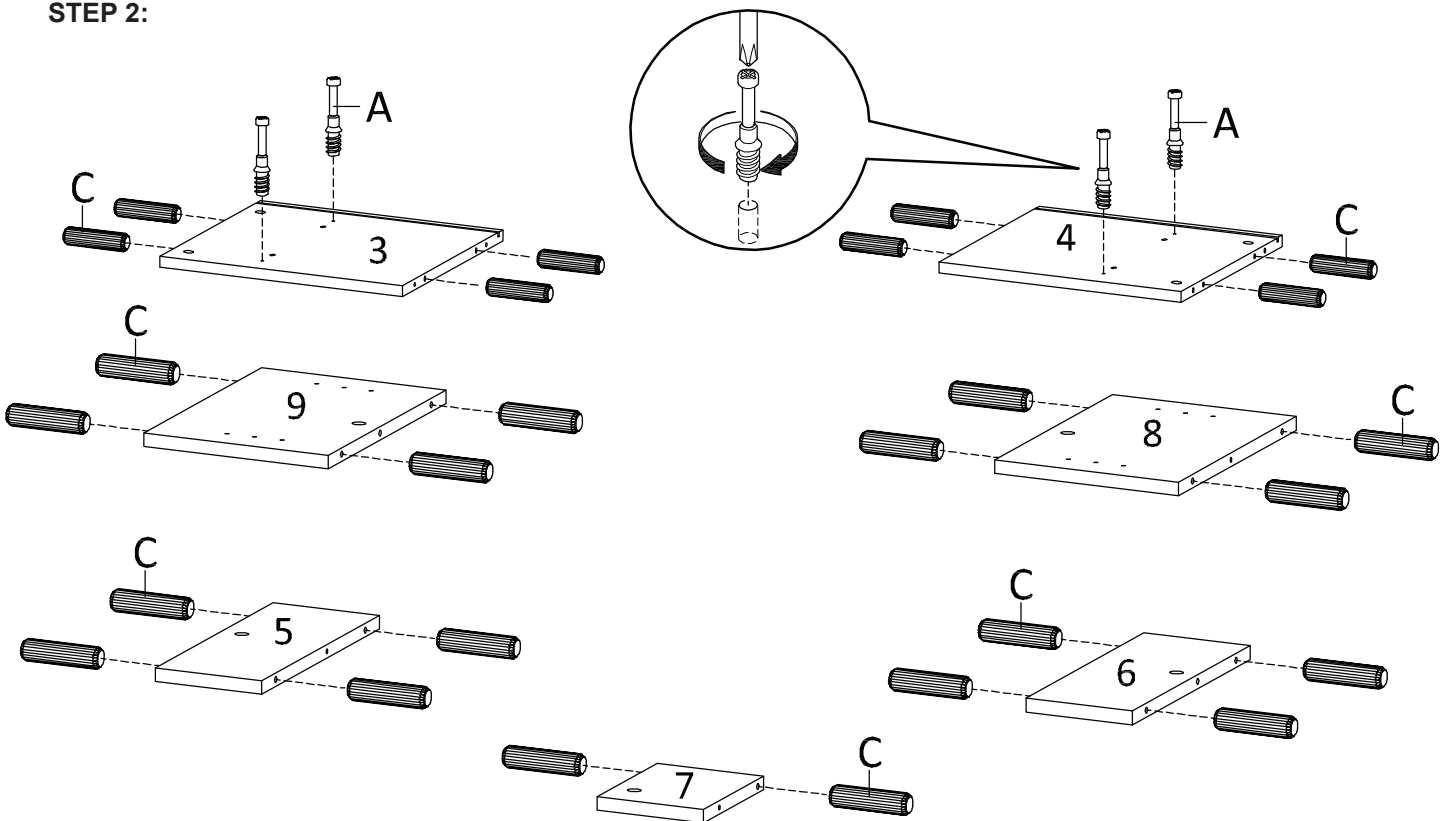
**STEP 2:**

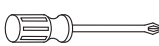

		
Ax4	Cx26	Sx1

Hardware required.  
Screwdriver not included

**STEP 3:**

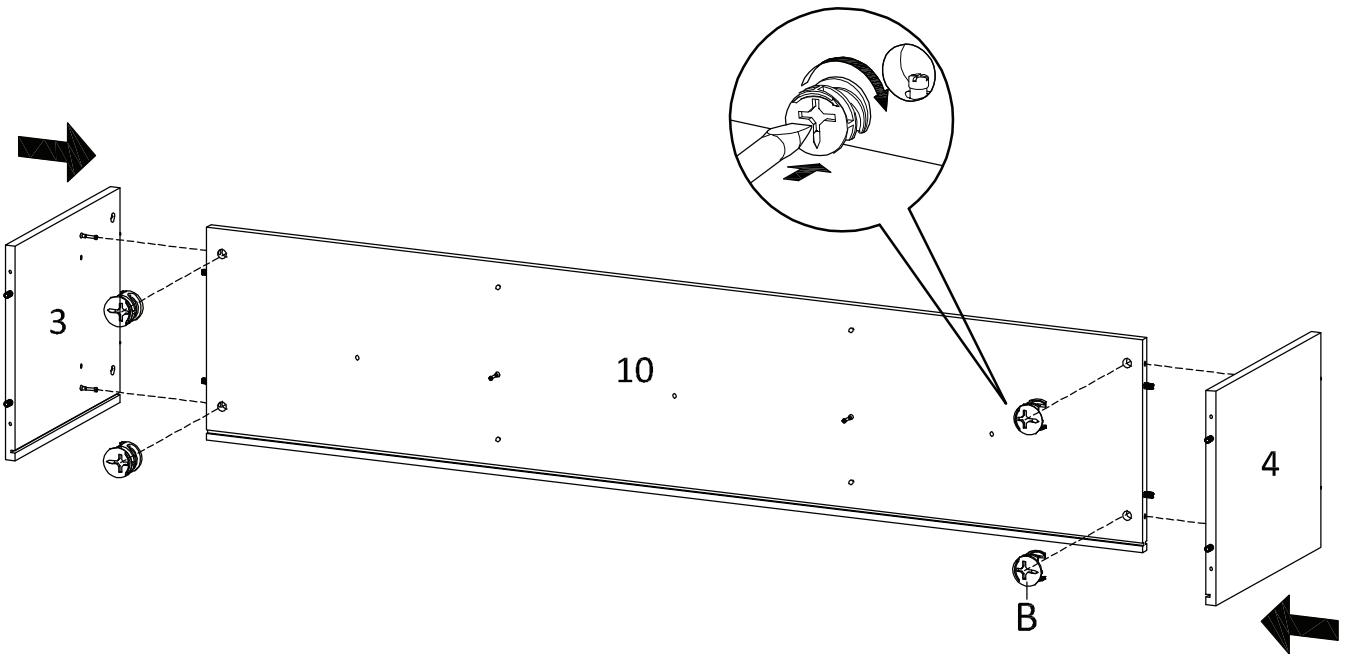

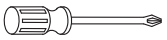

	
Bx4	Sx1

Hardware required.

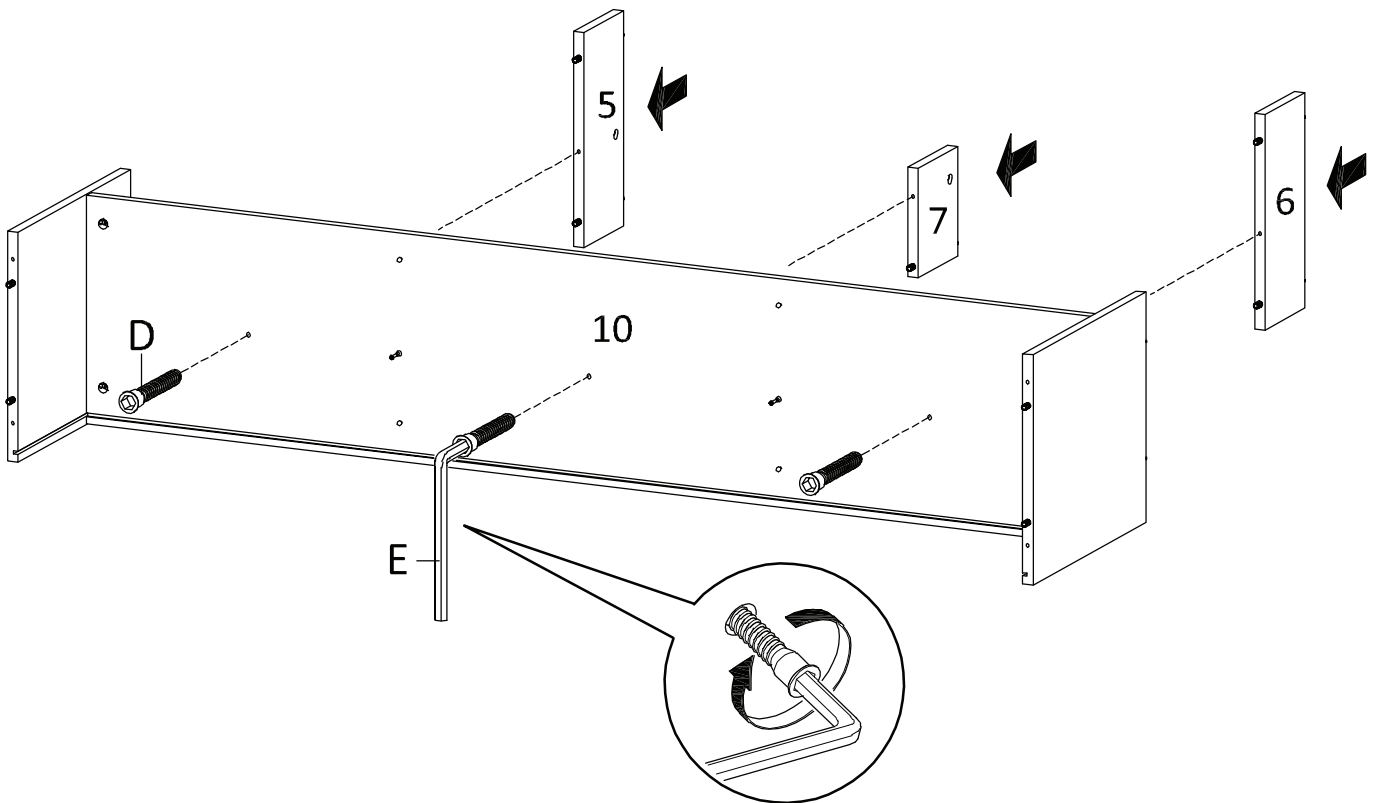
**STEP 4:**





	
Dx3	Ex1

Hardware required.

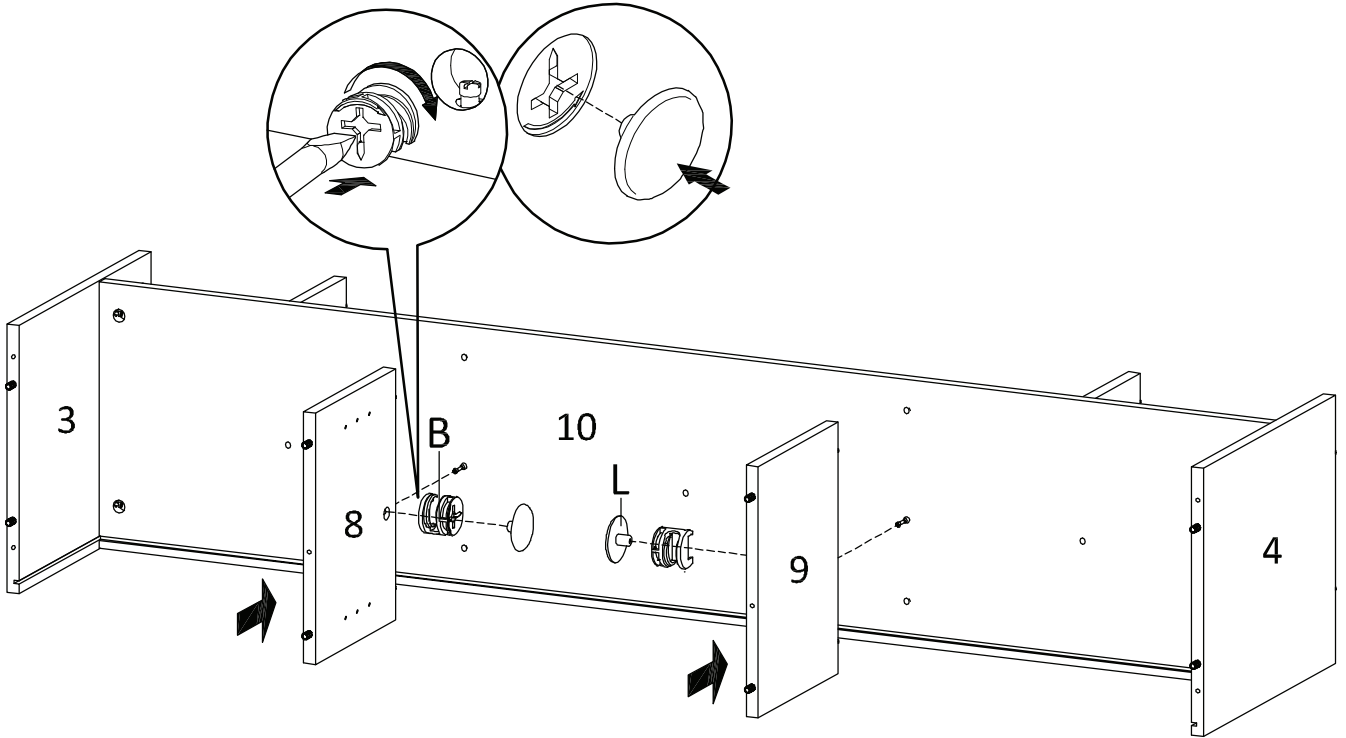
**STEP 5:**



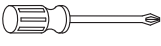

		
Bx2	Lx2	Sx1

Hardware required.  
Screwdriver not included

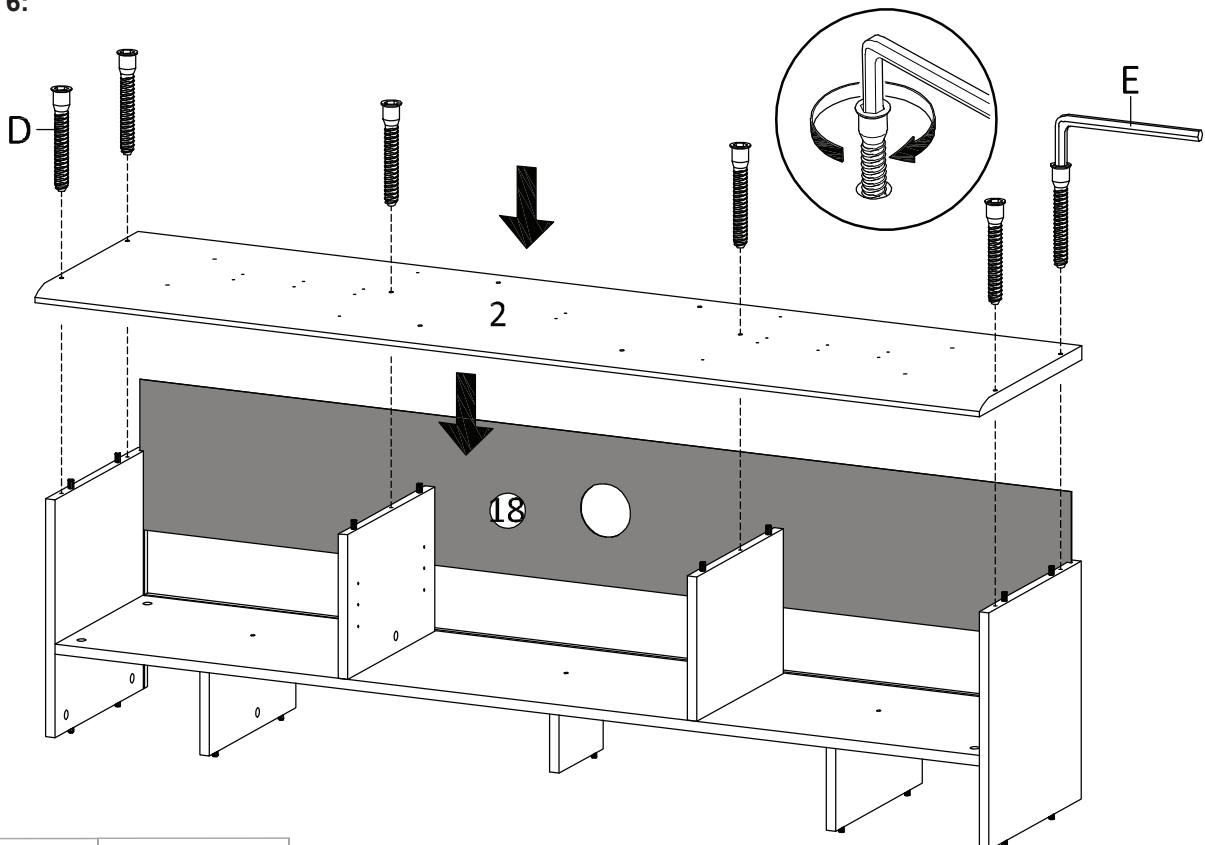
**STEP 6:**



	
Dx6	E

Hardware required.

**STEP 7:**

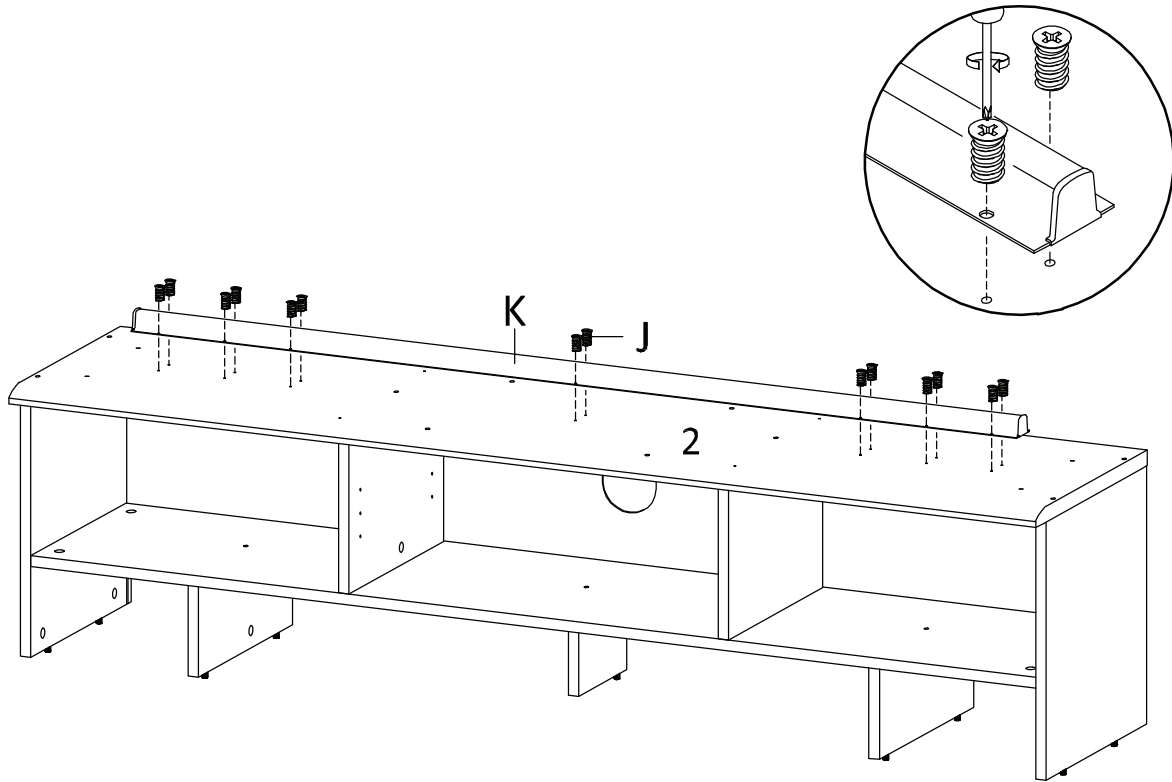

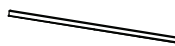
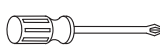

		
Jx14	Kx1	Sx1

Hardware required.  
Screwdriver not included

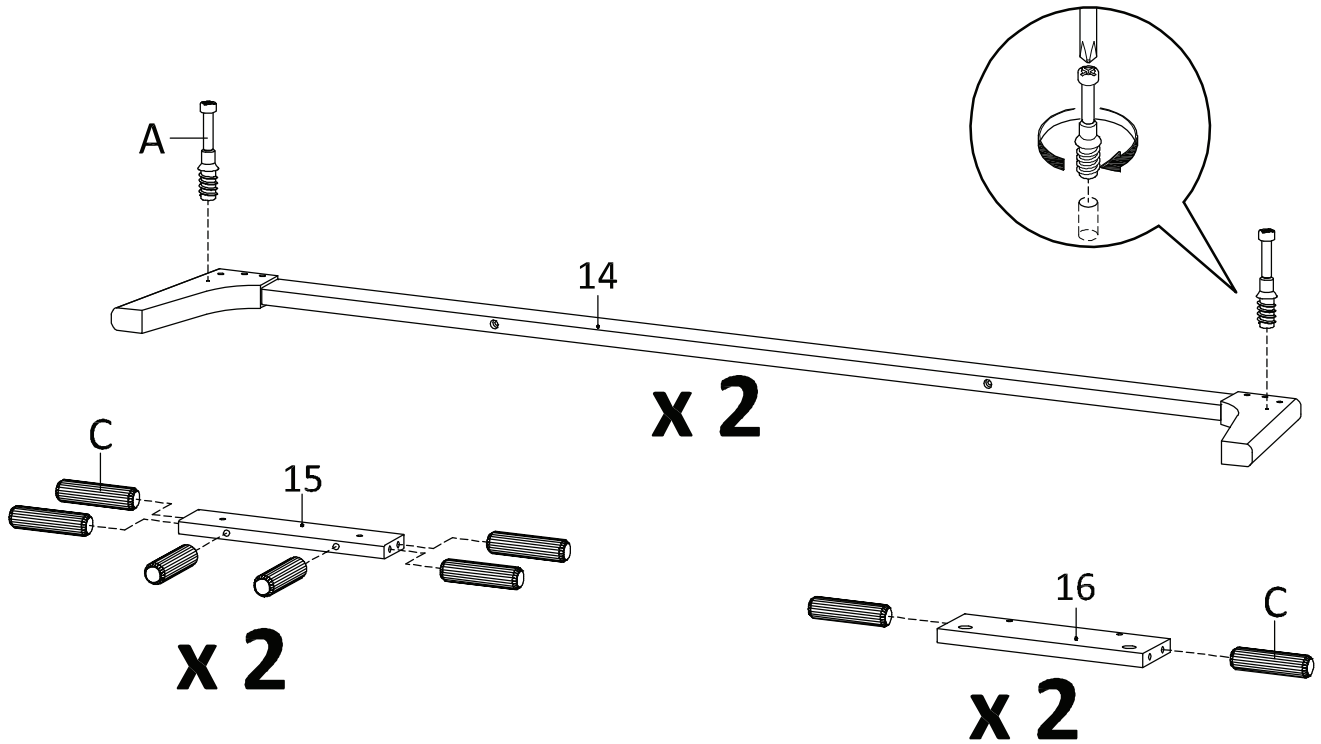
**STEP 8:**



		
Ax4	Cx16	Sx1

Hardware required.  
Screwdriver not included

**STEP 9:**

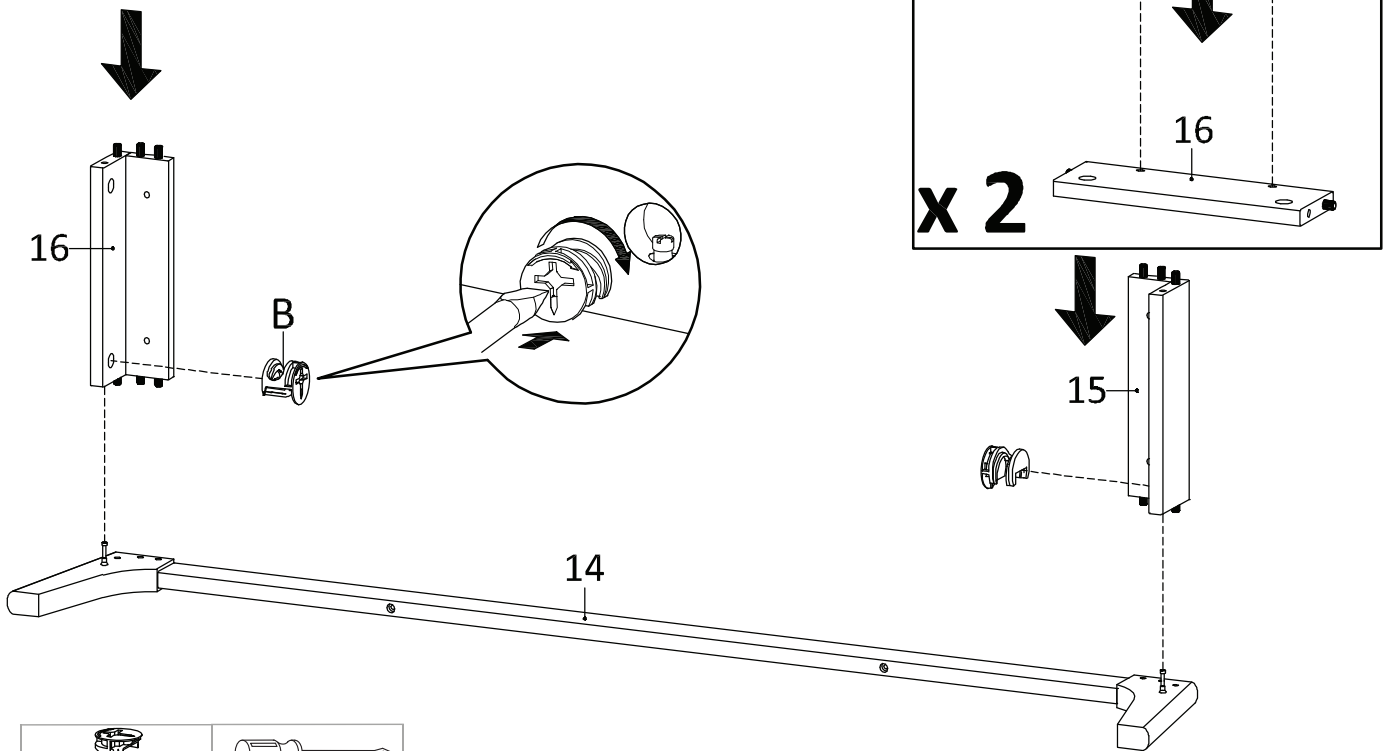

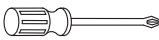
	
Bx2	Sx1

Hardware required.  
Screwdriver not included

**STEP 10:**

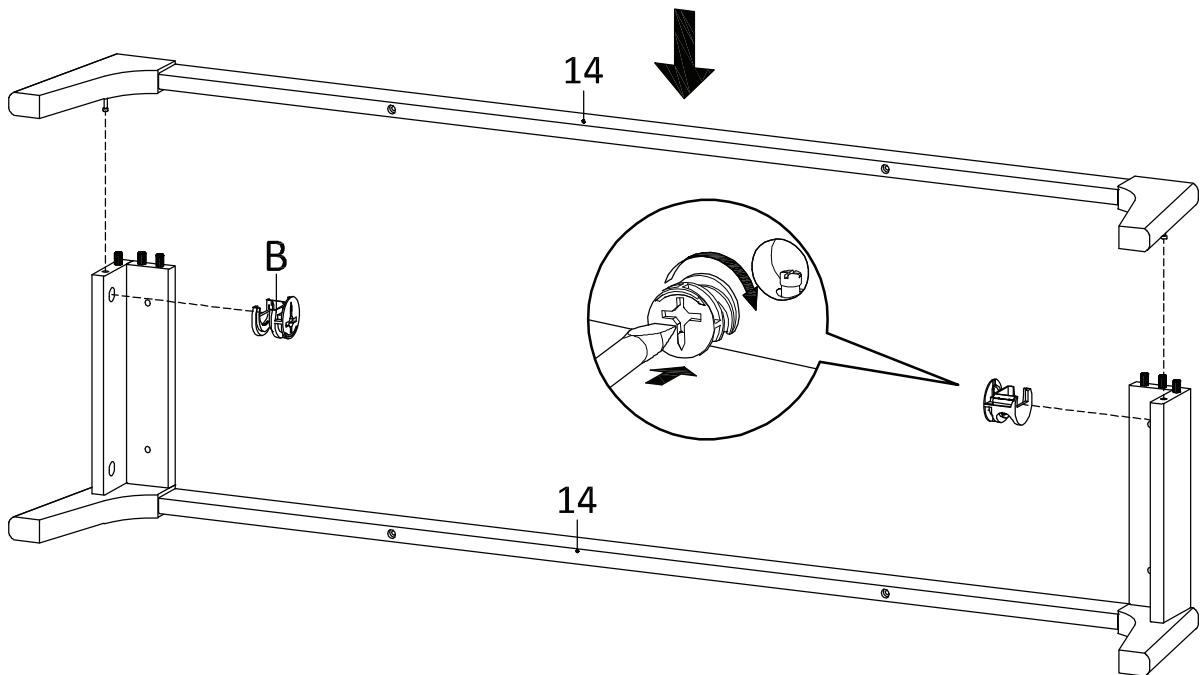

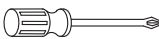
	
Bx2	Sx1

Hardware required.  
Screwdriver not included

**STEP 11:**

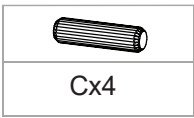
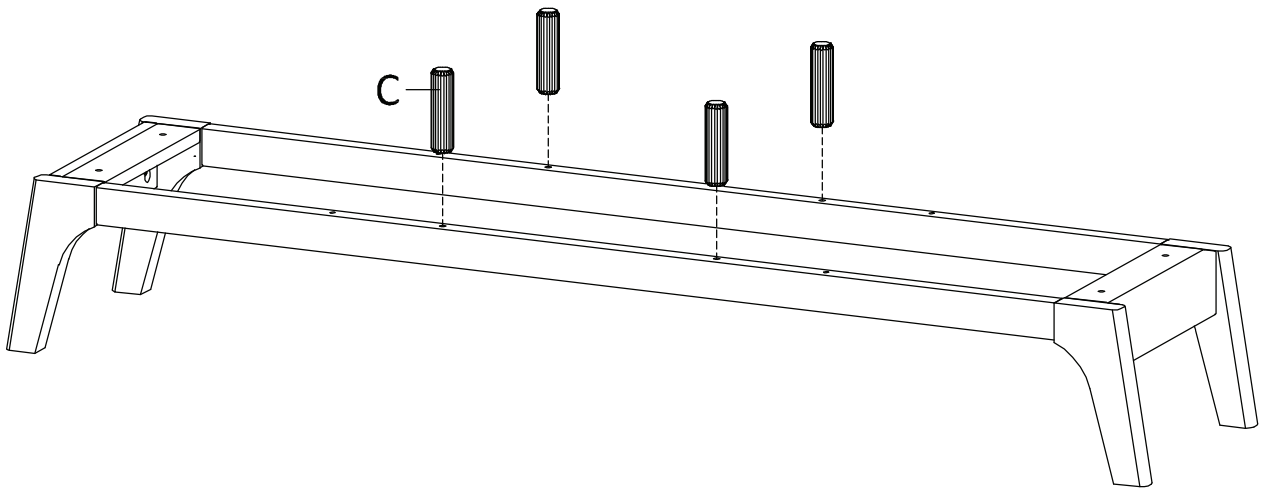

Cx4

Hardware required.

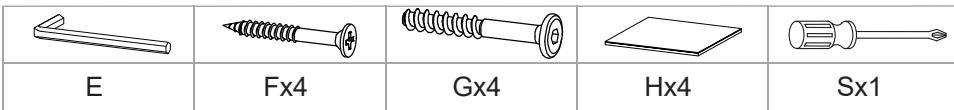
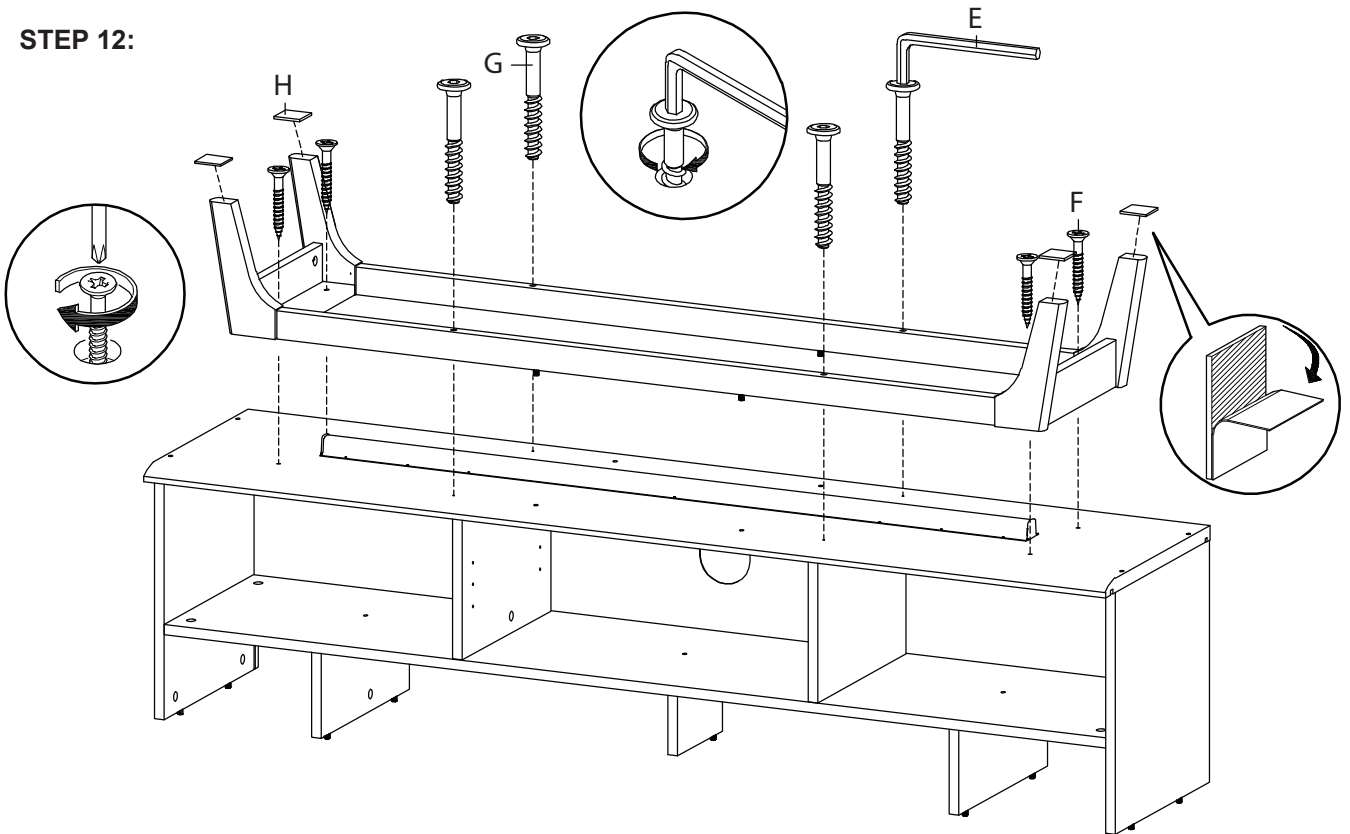

**STEP 12:**

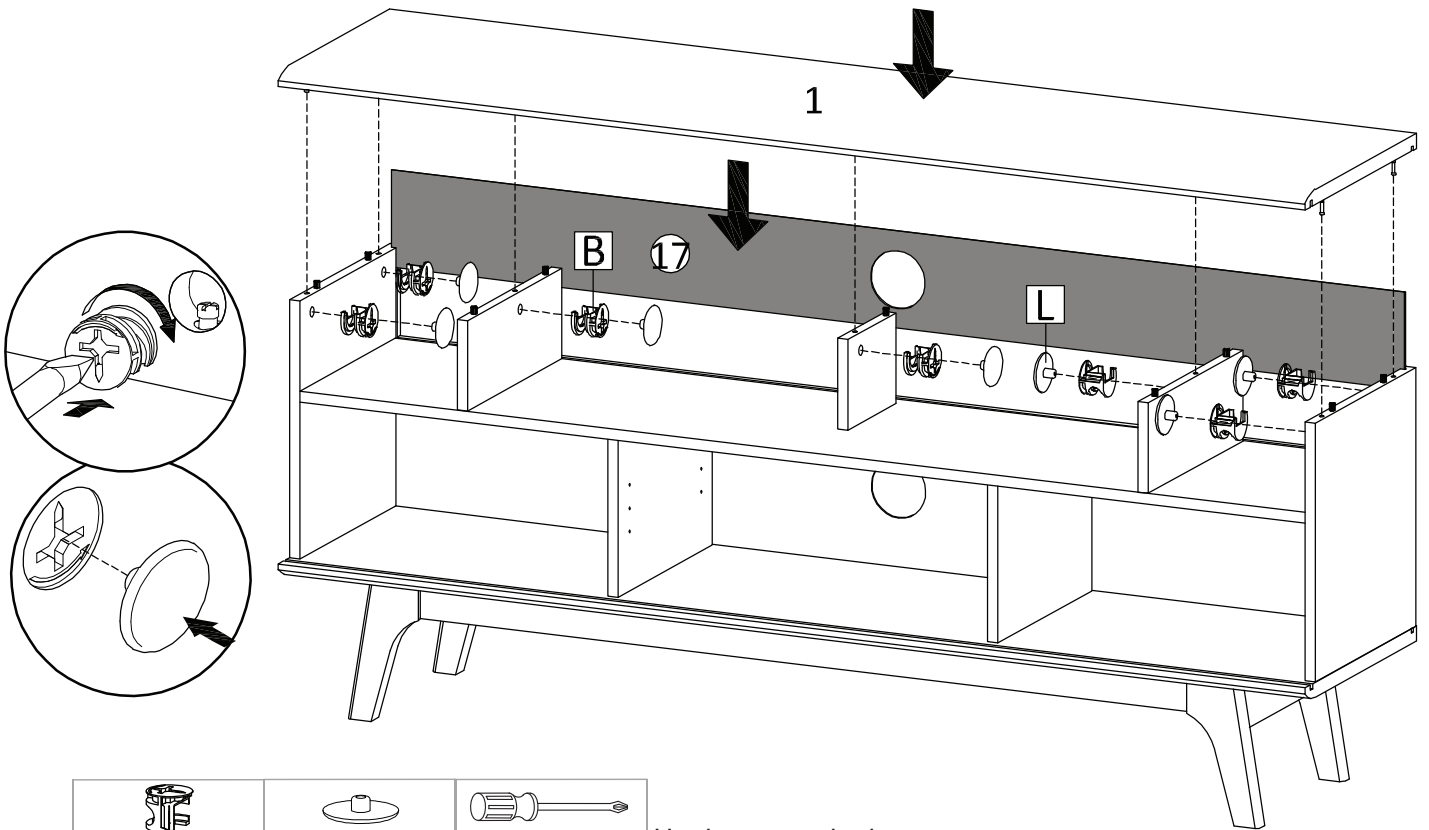

Hardware required.  
Screwdriver not included

**STEP 13:**



		
Bx7	Lx7	Sx1

Hardware required.  
Screwdriver not included

**STEP 14:**

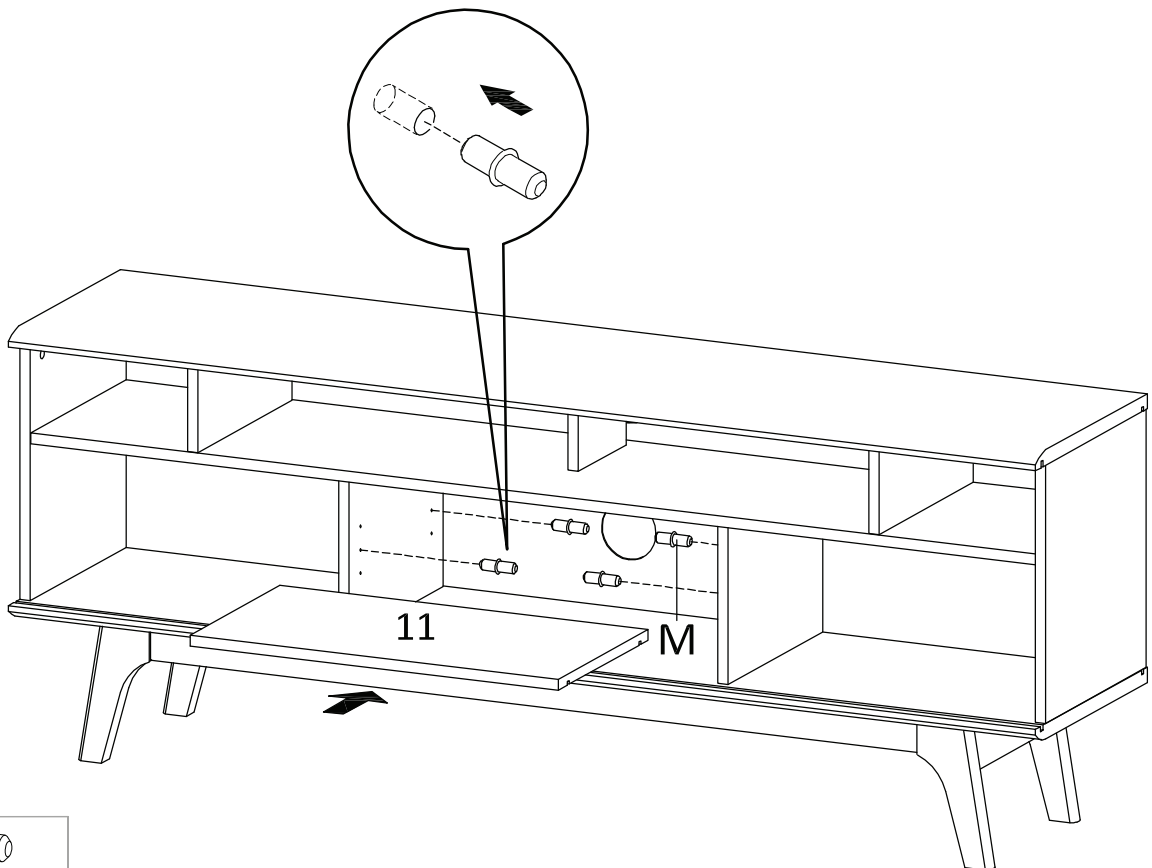

Mx4

Hardware required.

**STEP 15:**

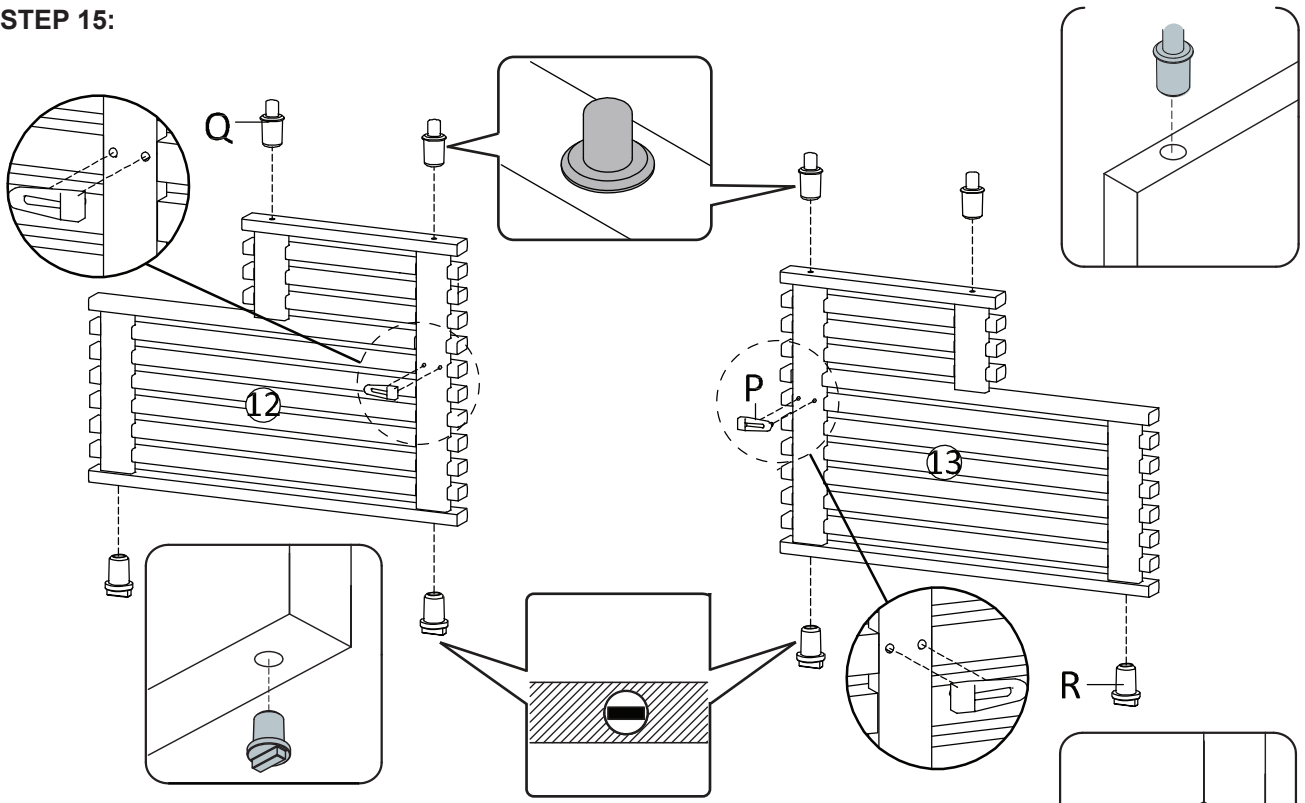

Px2	Qx4	Rx4

Hardware required.

**STEP 16:**

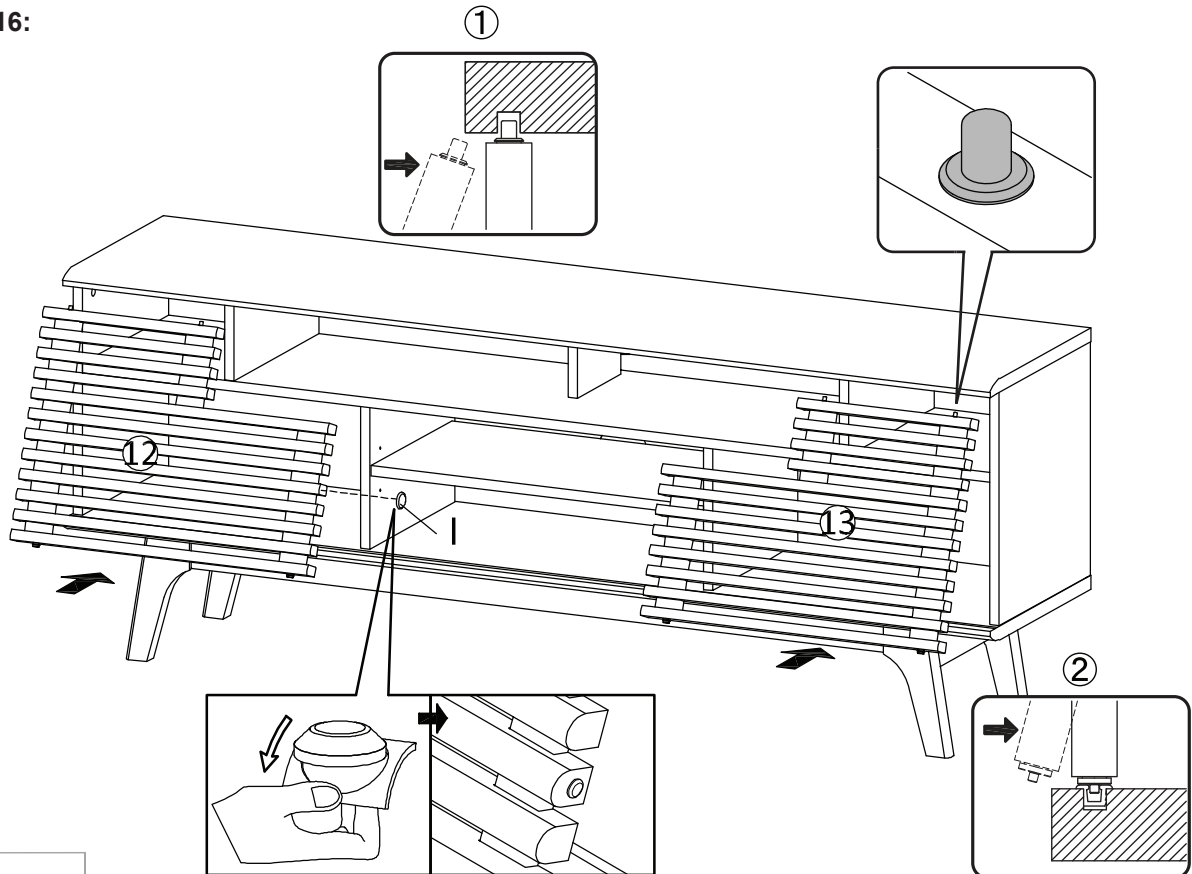



Ix1

Hardware required.

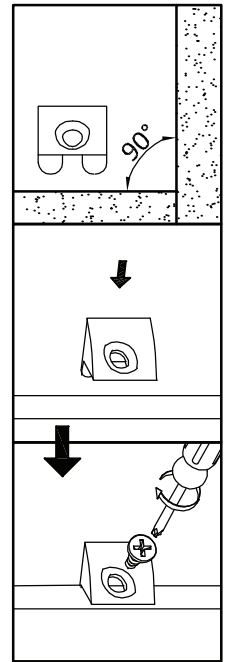
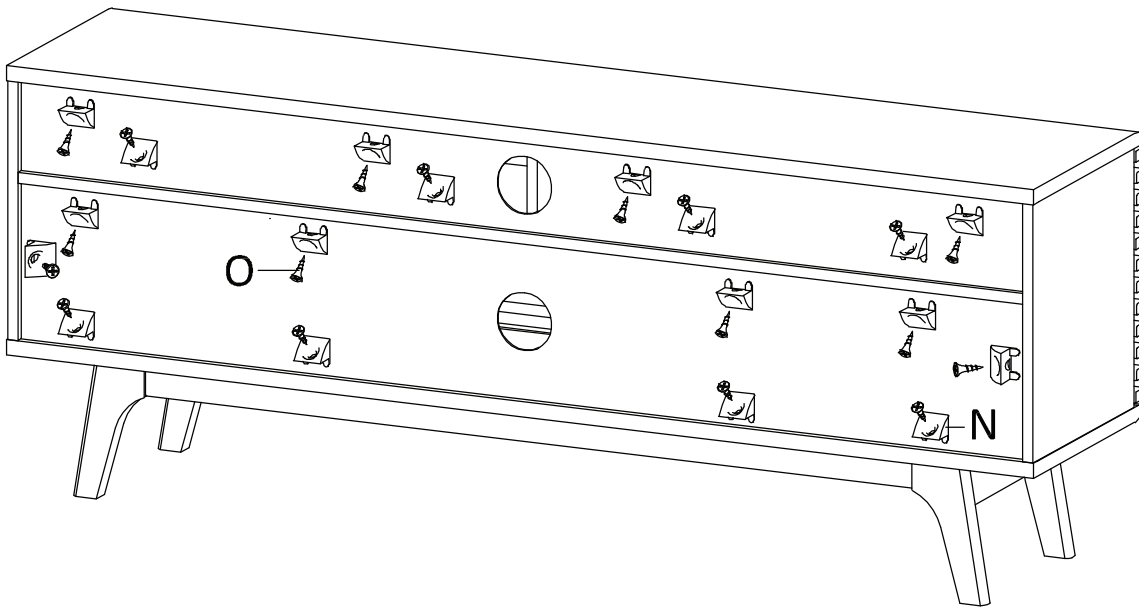
**STEP 17:**

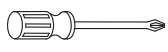

		
Nx18	Ox18	Sx1

Hardware required.  
Screwdriver not included

**STEP 18:**

