

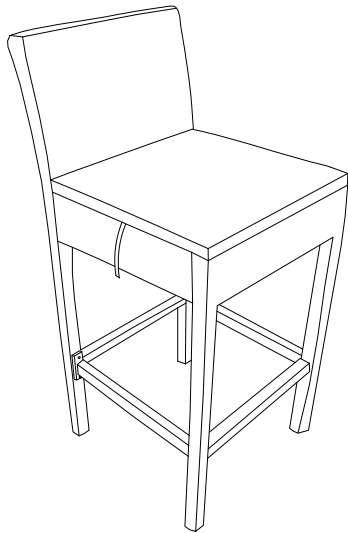



BAR STOOL

Before you start, here are some helpful advice:

1. We suggest you spend a short time reading through this leaflet and then follow the simple step by step instructions.
2. Owing to the size and weight of the bar stool, we recommend that it is assembled by two adults, on a carpeted or padded area, in the room that it is intended for. Approximate assembly time: 30 minutes.
3. Please do not use any tools other than those provided or recommended in these instructions.
4. Please do not throw away any of the packaging or instructions until you have checked all the components and hardware and the furniture is fully assembled.
5. Assemble all components loosely until advised to tighten. Depending on use, it may be necessary to tighten the components from time to time, so please save the tools that have been provided.
6. Please keep all pieces out of reach of children.



Hardware:

A		Short Bolt x20mm	x 8
B		Long Bolt x40mm	x 8
C		Flat Washer	x 16
D		Allen Wrench	x 1

Components:

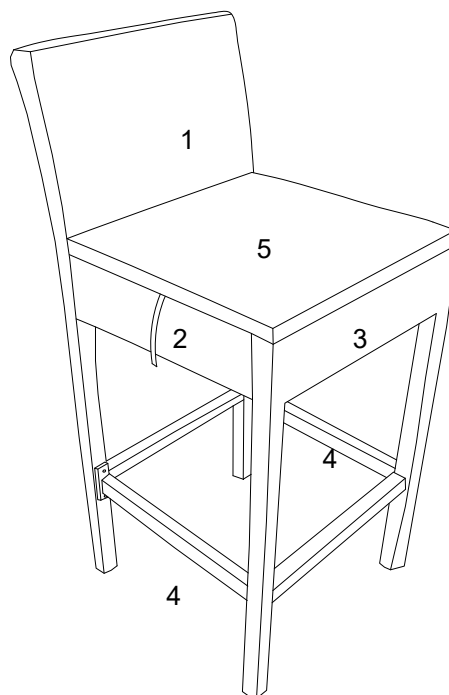

1	Bar Stool Back	x1	2	Bar Stool Seat	x1	3	Bar Stool Front	x1
4	Stretcher	x2	5	EEI-1006 Seat Cushion (Packed separately)				

BAR STOOL

STEP 1:



Please put **Bar Stool Back (1)** on a carpeted or padded area.

Place **Bar Stool Seat (2)** to **Bar Stool Back (1)** as shown.

Insert 4 pieces of **Long Bolt (B)** with 4 pieces of **Flat Washer (C)** into the holes on **Bar Stool Back (1)** through the holes on **Bar Stool Seat (2)**.

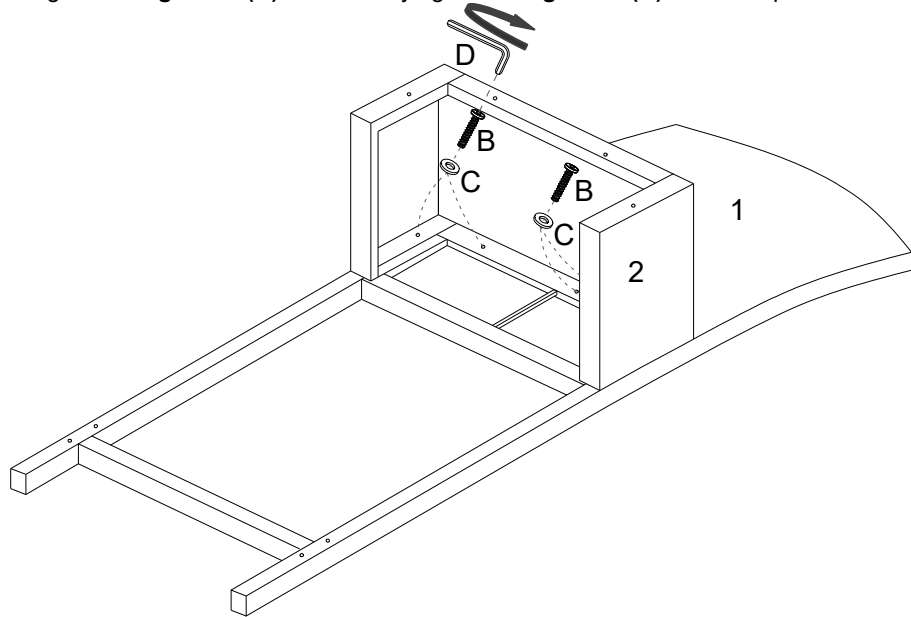
Use **Allen Wrench (D)** to tighten **Long Bolts (B)**. Do not fully tighten **Long Bolts (B)** at this step.



		
Bx4	Cx4	Dx1

Hardware & Tool required



STEP 2:

Place **Stretchers (4)** to the assembled **Bar Stool Back (1)** and **Bar Stool Seat (2)** as shown.

Insert 4 pieces of **Short Bolt (A)** with 4 pieces of **Flat Washer (C)** into the holes on **Bar Stool Back (1)** through the holes on **Stretchers (4)**.

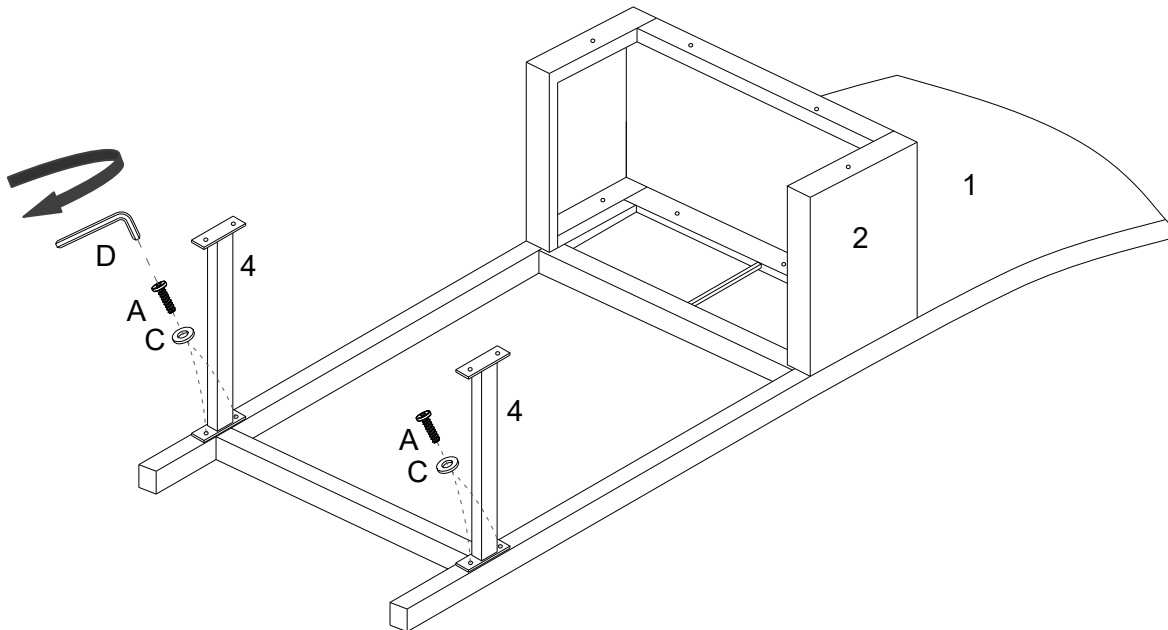
Use **Allen Wrench (D)** to tighten **Short Bolts (A)**. Do not fully tighten **Short Bolts (A)** at this step.



		
Ax4	Cx4	Dx1

Hardware & Tool required

BAR STOOL

STEP 3:

Put **Bar Stool Front (3)** to the assembled **Bar Stool Back (1)**, **Bar Stool Seat (2)** and **Stretchers (4)** as shown.

Insert 4 pieces of **Long Bolt (B)** with 4 pieces of **Flat Washer (C)** into the holes on **Bar Stool Front (3)** through the holes on **Bar Stool Seat (2)**

Insert 4 pieces of **Short Bolt (A)** with 4 pieces of **Flat Washer (C)** into the holes on **Bar Stool Back (1)** through the holes on **Stretchers (4)**.

Use **Allen Wrench (D)** to tighten all the **Short Bolts (A)** and **Long Bolts (B)**. Do not fully tighten the **Bolts (A&B)** at this step.

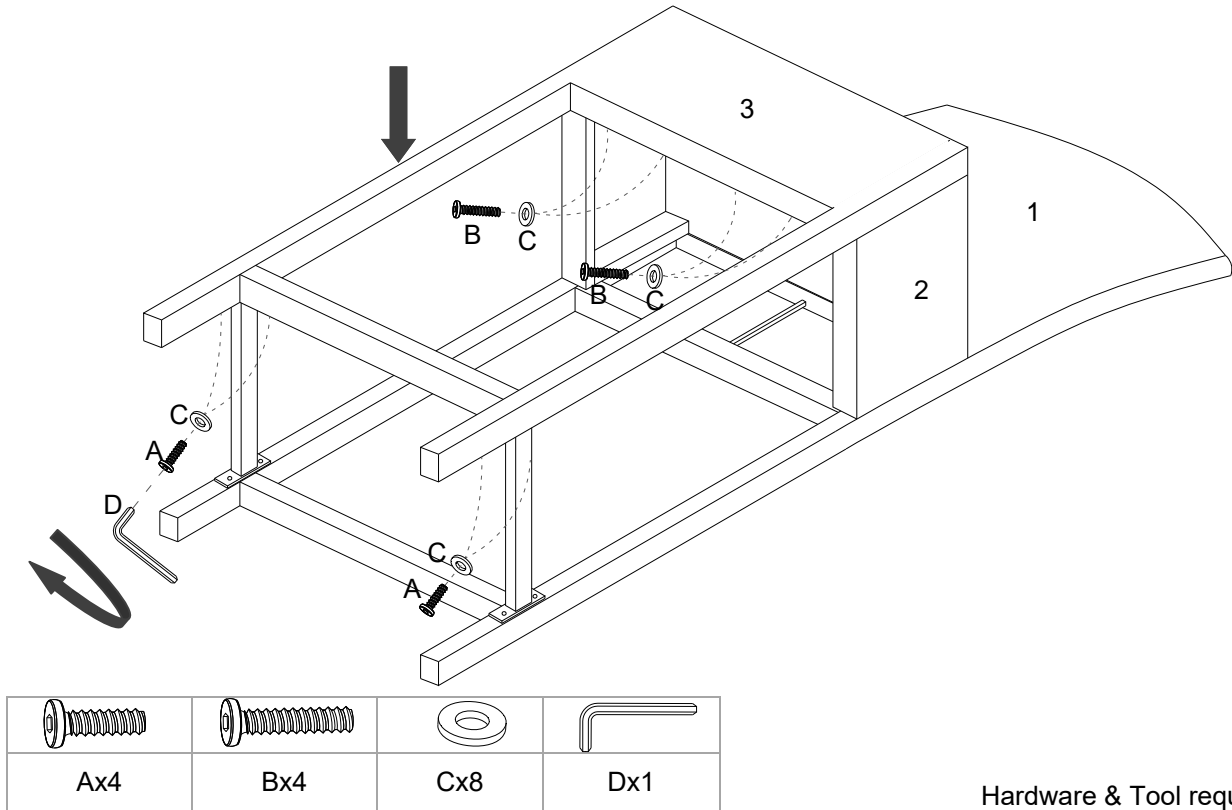

Hardware & Tool required

STEP 4:

Carefully turn over the assembled Bar Stool.

Please put a heavy object or seat one adult on top of the assembled Bar Stool to press the bar stool for leveling.

Use **Allen Wrench (D)** to tighten all the **Short Bolts (A)** and **Long Bolts (B)** clockwise until secure.

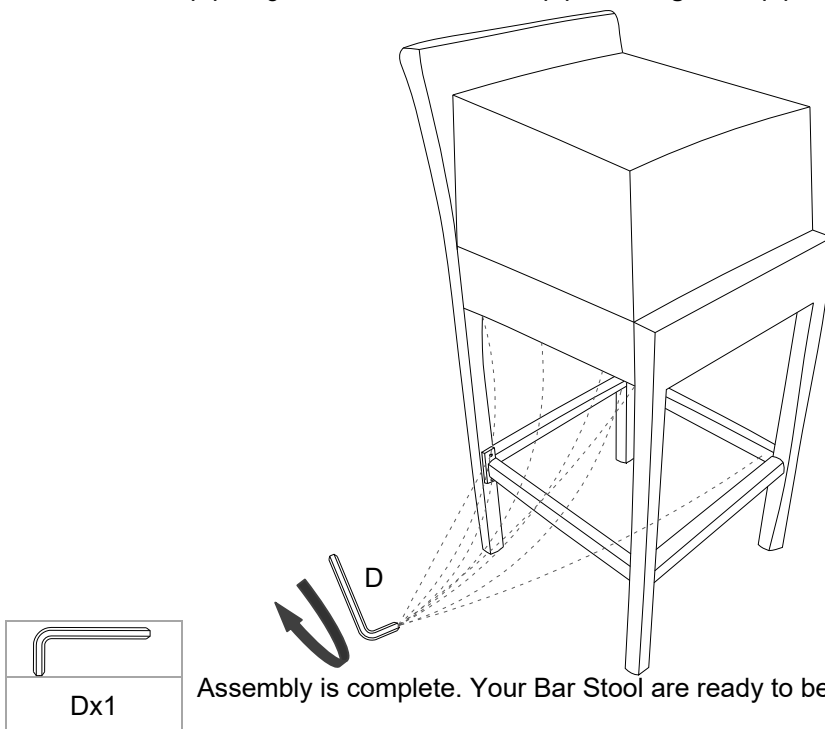

Assembly is complete. Your Bar Stool are ready to be used now!

Hardware & Tool required

BAR STOOL

STEP 5:

Carefully put **Seat Cushion (5)** to **Bar Stool Seat (2)**.

Fasten **Seat Cushion (5)** to **Bar Stool Seat (2)** by using the band on **Seat Cushion (5)** as shown.

