

Office Chair

Silla de Oficina

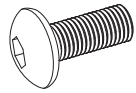

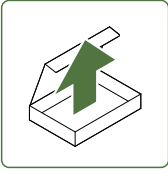

M6 x 14mm

A x 10

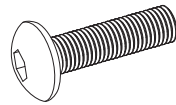

M6 x 20mm

B x 4



M6

C x 8

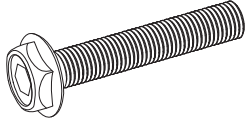

M6 x 35mm

D x 4

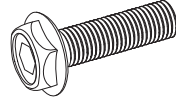

M6 x 20mm

E x 4

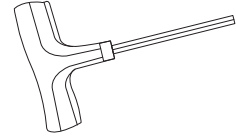

F x 1

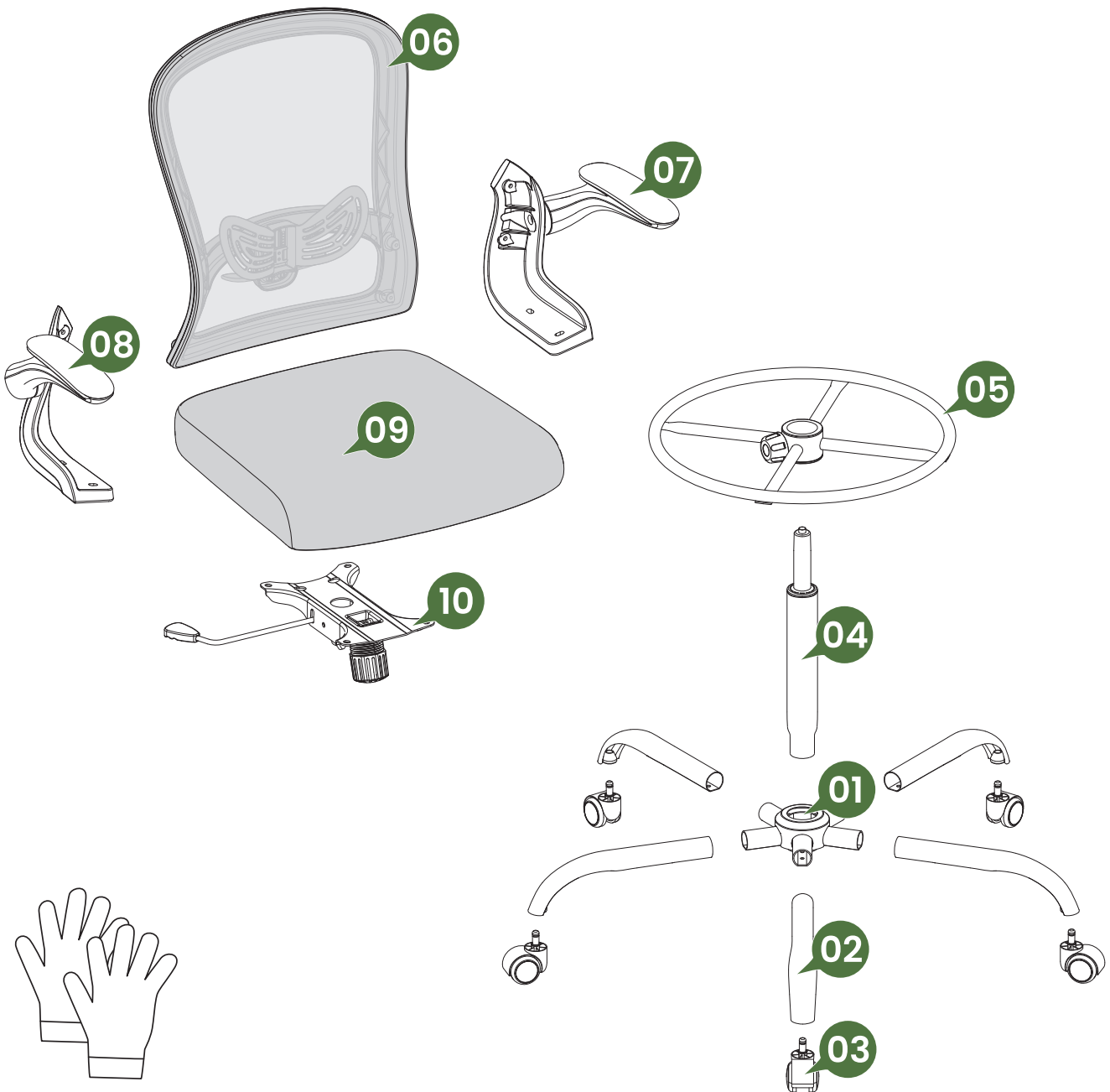

1

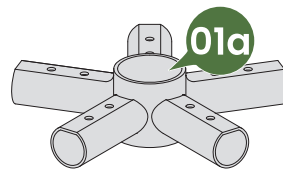
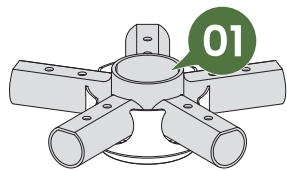

M6 x 14mm
A x 10



F x 1

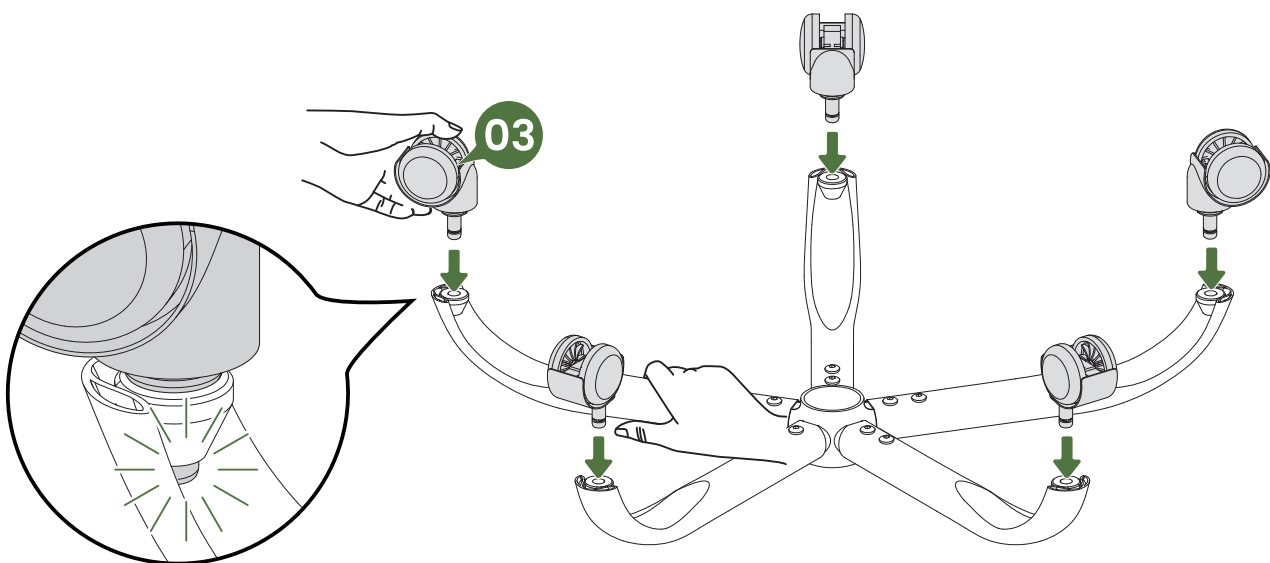
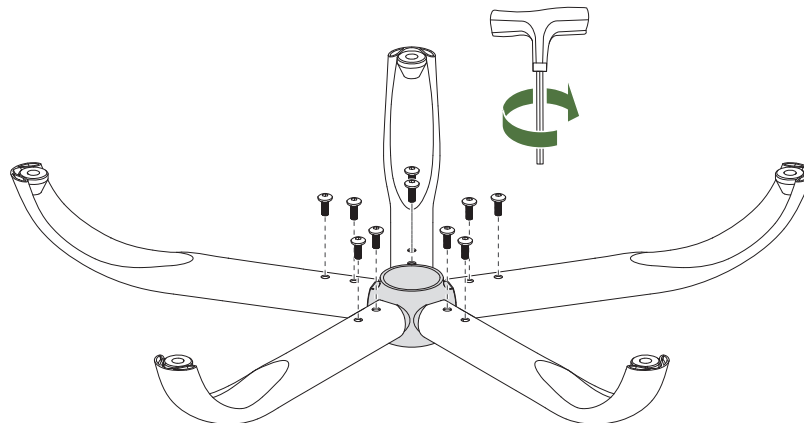
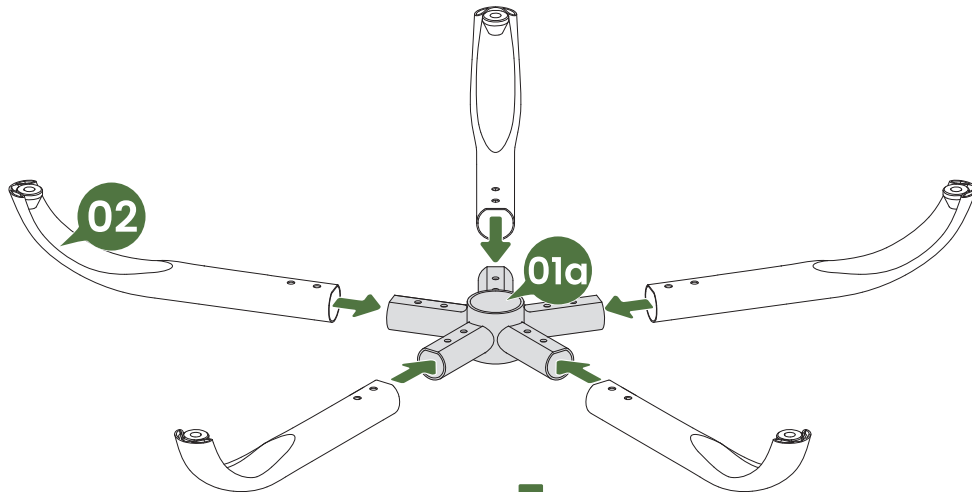
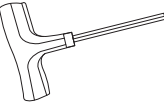

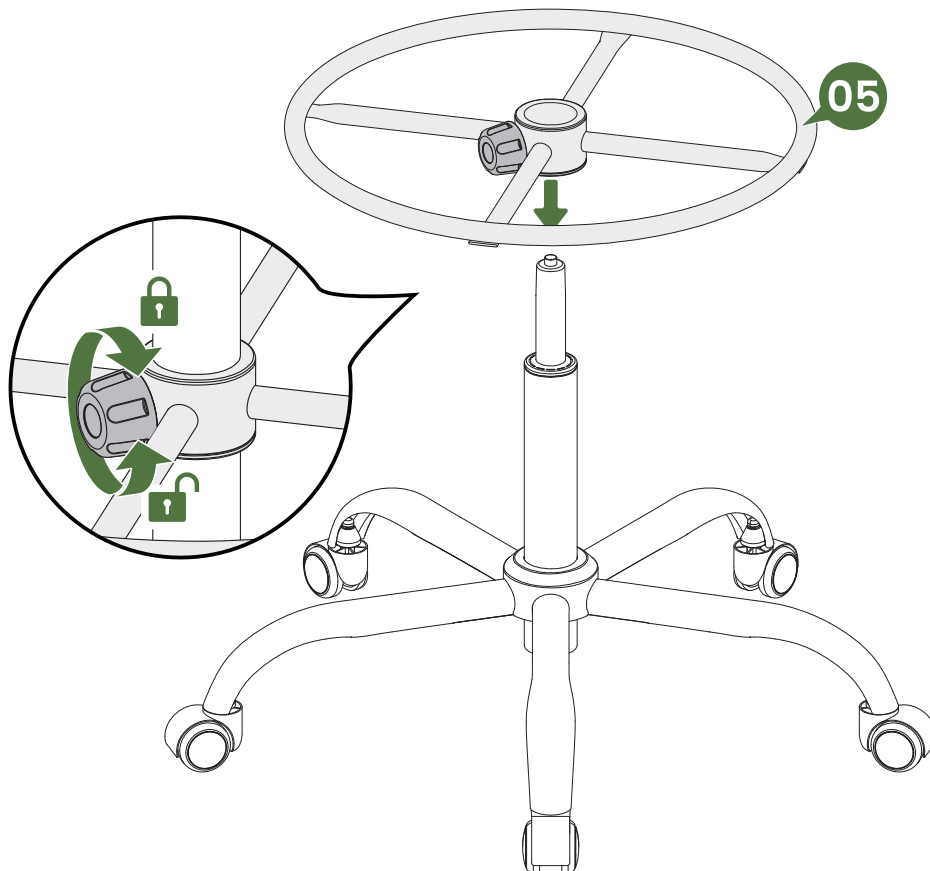
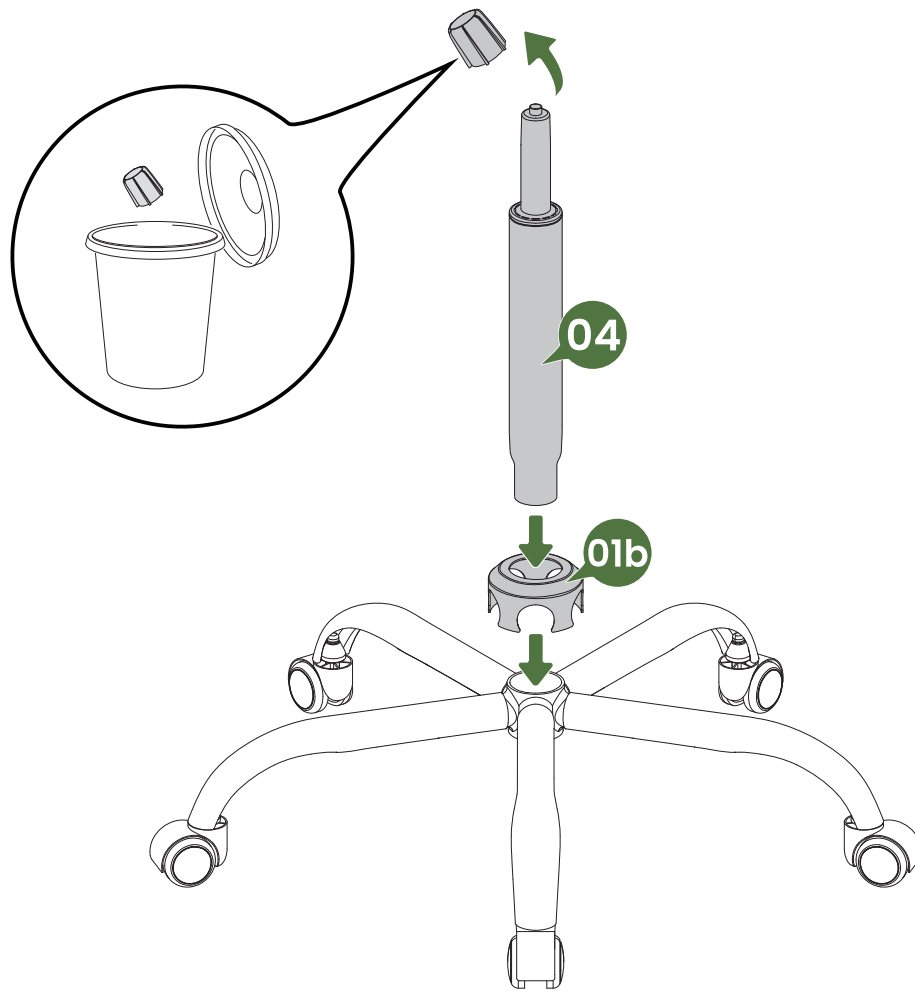



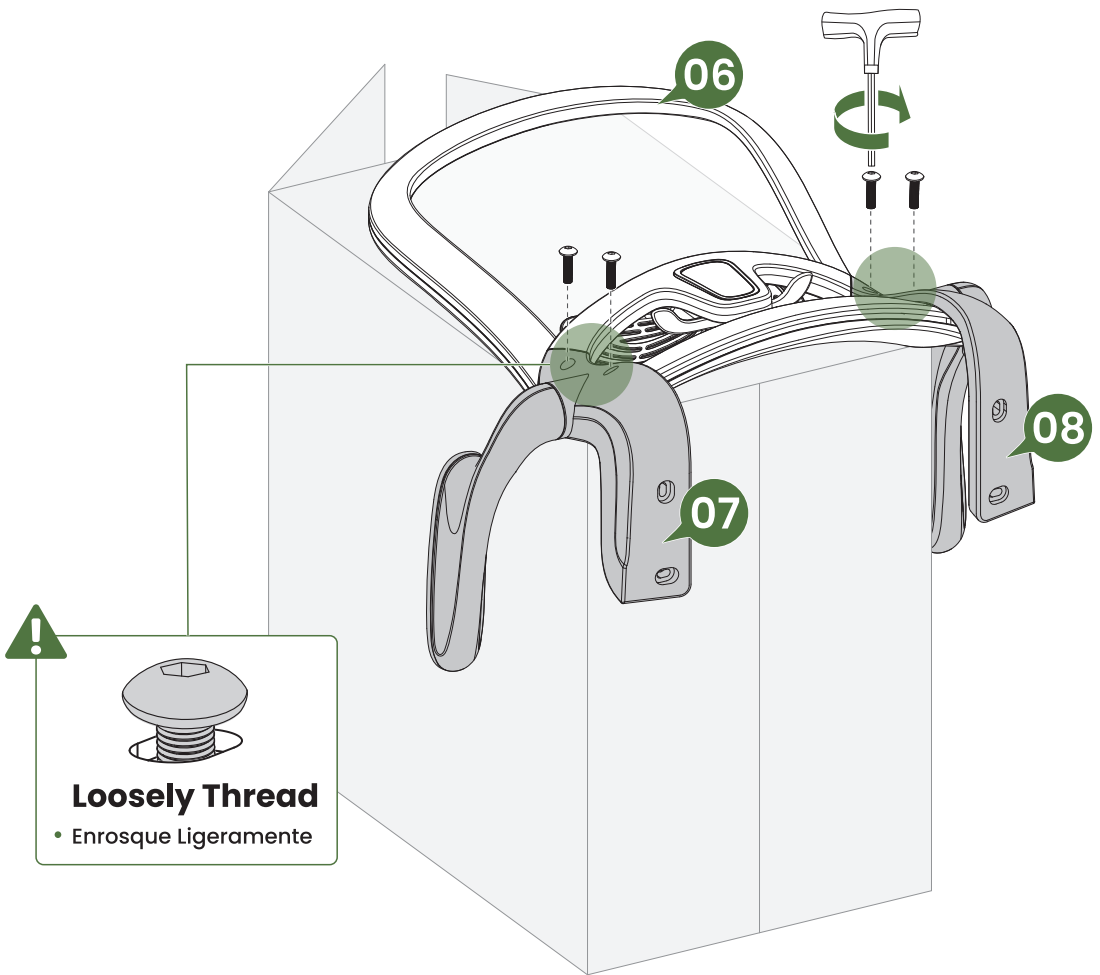
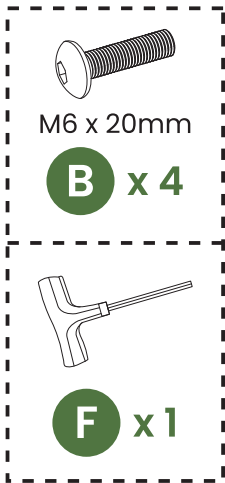

2

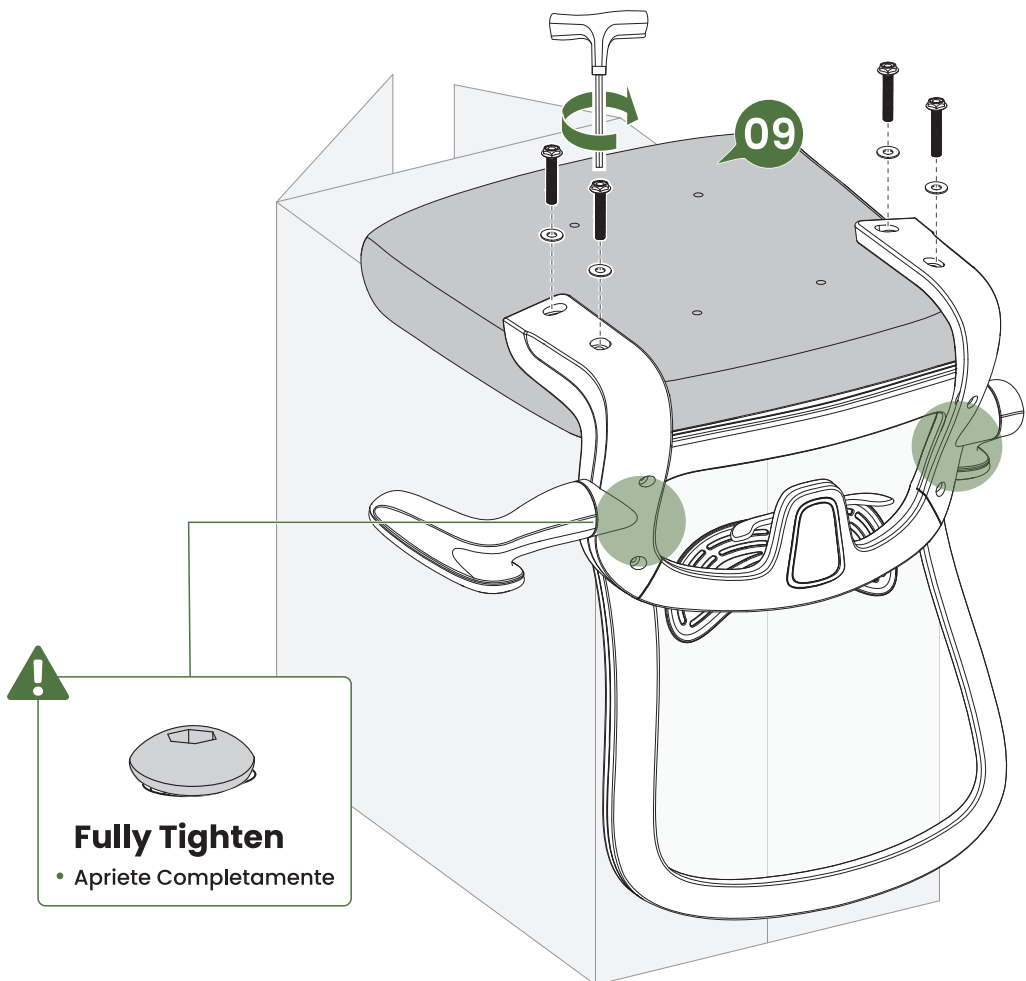
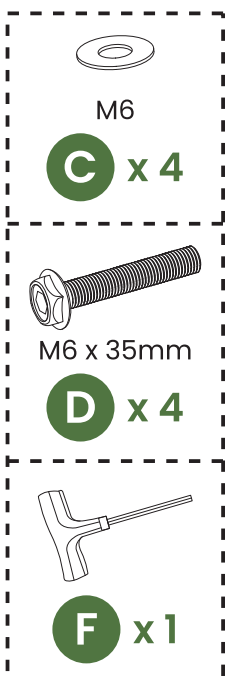

3

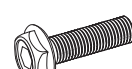

4

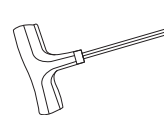
-  M6
-  **C** x 4
-  M6 x 20mm
-  **E** x 4
-  **F** x 1

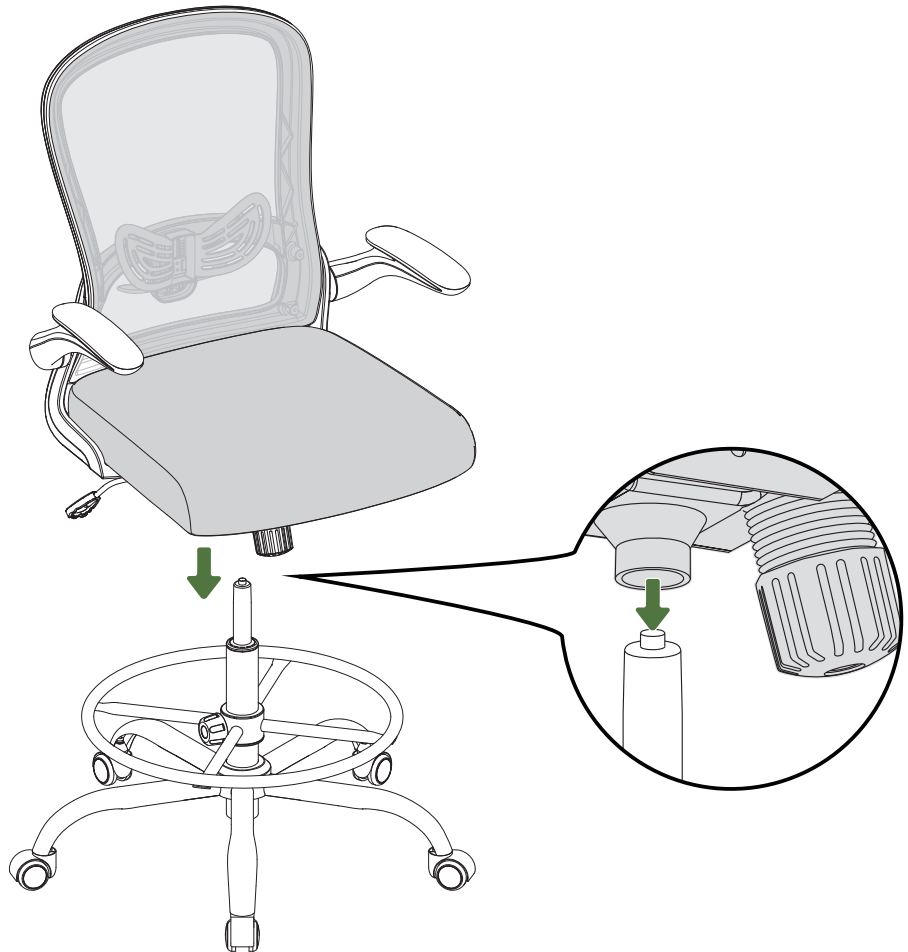
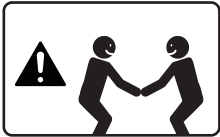
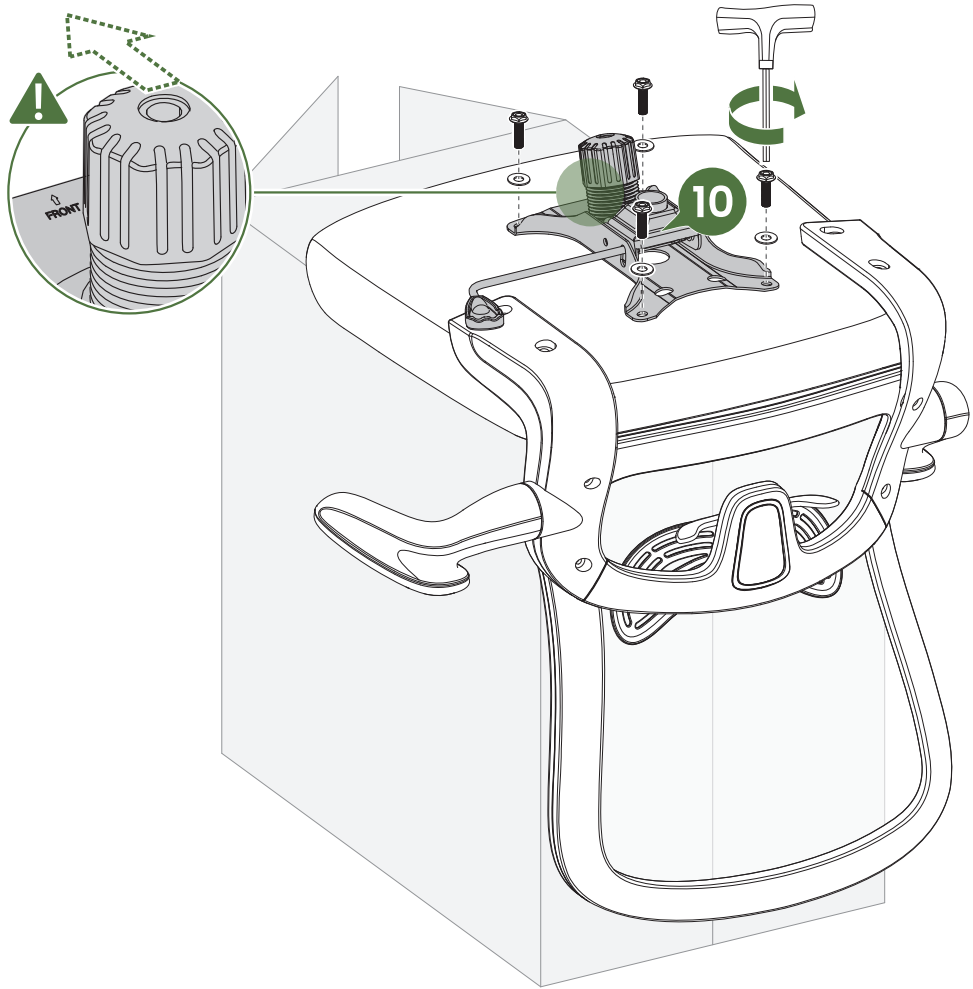

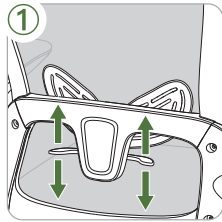
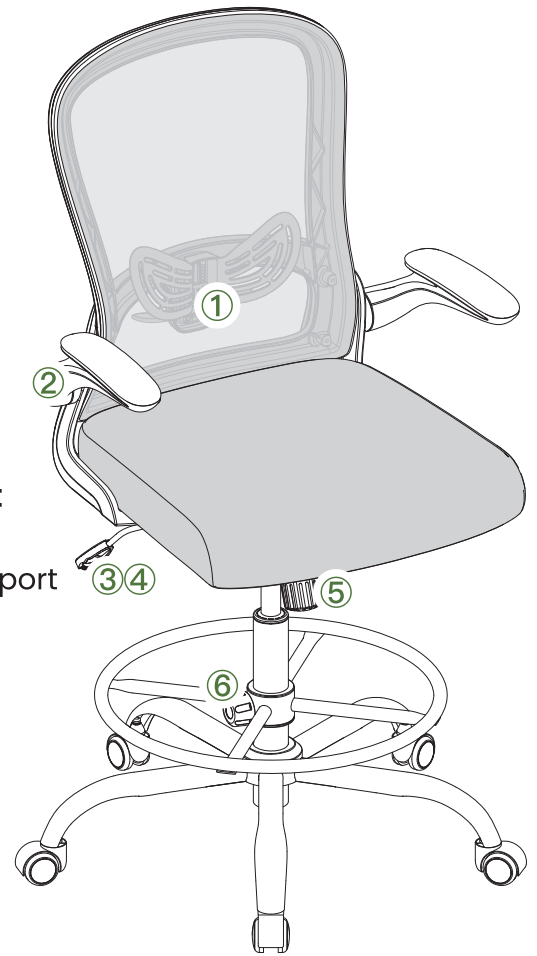

Lumbar Support Height Adjustment:

Grip both sides of the support to adjust it up or down.

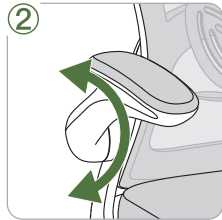
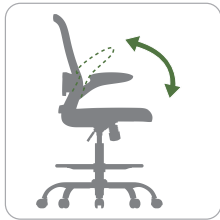

Folding Armrest:

Lower the armrest for support or raise it up when not in use.

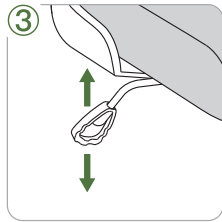
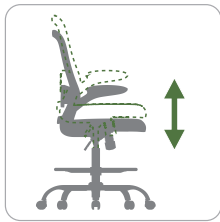

Seat Height Adjustment:

To raise the seat, lift your body off the chair, then pull the lever up. To lower the seat, rest your body in the chair, then pull the lever up.

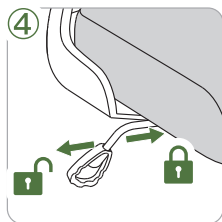
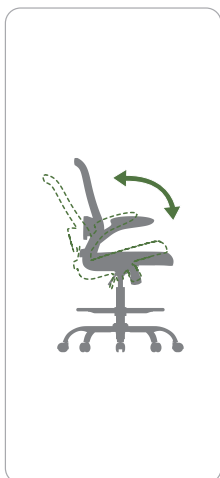

Backrest Rocking Function:

Pull the lever out to enable the rocking function. The chair will rock back and forth with the user rather than being locked in a fixed position. Return the lever to its original position to lock.

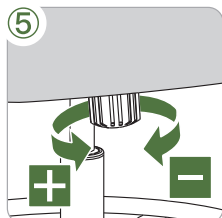

Backrest Tilt Tension Adjustment:

Turn the knob [+] or [-] to adjust the rocking tension. Increase for heavier user, and decrease for lighter user.

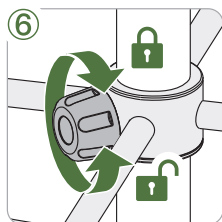
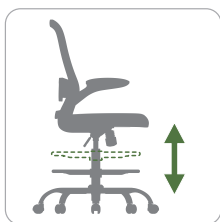

Footrest Ring Height Adjustment:

Turn the knob counter-clockwise to unlock. Lower or raise the footrest ring to the desired position, then turn the knob clockwise to lock.

IMPORTANT SAFETY INFORMATION



Home Office Use



Only (1) person should sit in the chair at a time.



Sit correctly in the chair with weight centered over the base.

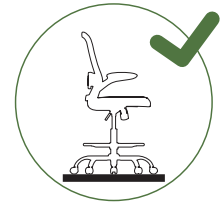

Only use the chair on level flooring.

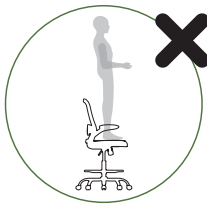

Do not stand on the chair or use it as a ladder or stair.

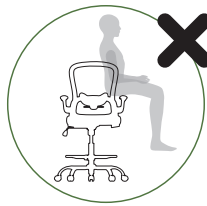

Sitting on the armrest can lead to damage and injury.



To avoid tipping over, do not lift legs up while tilting the backrest.

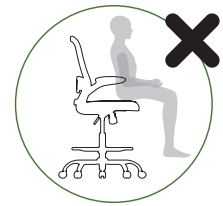

Do not sit on the edge of the chair.

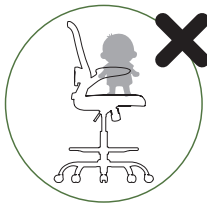

Children under 5 years of age should not operate the chair alone.

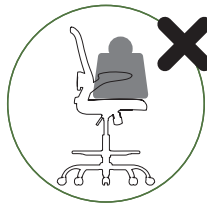

Do not put heavy objects on the chair, or use it as a trolley.

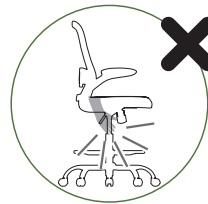

Keep hands away from the seat lift mechanism during operation.

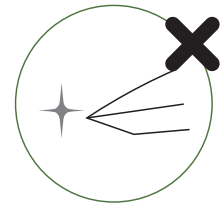

Do not use items with sharp edges or hooks near the chair.

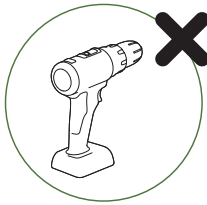

Use only hand tools. Do not use an electric drill.

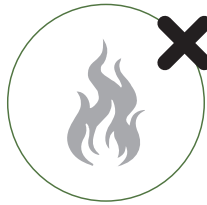

Keep the chair away from flame and heat sources.

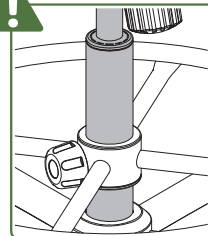

WARNING! Only trained personnel may replace or repair seat height adjustment components with energy accumulators.

CARE AND MAINTENANCE

- It is recommended that the office chair be thoroughly cleaned at least once a month to maintain its condition and functionality.
- Use a vacuum cleaner to suck up any dirt that may be resting on the seat.
- The casters will stick if not maintained regularly. Brush the casters with water and wipe clean with a damp cloth.
- If dirt solidifies on the surface of the casters, use soap and water to clean it off.
- Use a dry cloth to finish cleaning, or leave your office chair in a ventilated area to air dry.
- Direct sunlight can ruin an office chair over time, degrading most fabrics and materials. Keep your office chair out of direct sunlight.
- Humid conditions may lead to the formation of mildew on fabric and/or rust on metal parts. Do not keep your office chair in a damp environment.
- Be careful with drinks, food, or any type of liquids when you are near your chair. If a spill happens, clean and attend to stains immediately.
- Avoid the use of sharp objects or blades near the office chair that may cause damage.
- If possible, cover the chair to protect it from dirt and dust.
- **Examine the chair and retighten all fasteners every 6 months to ensure they are secure, including those connecting the seat, backrest, and chair mechanism.**

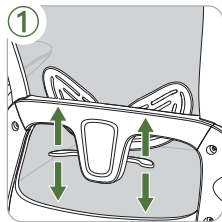
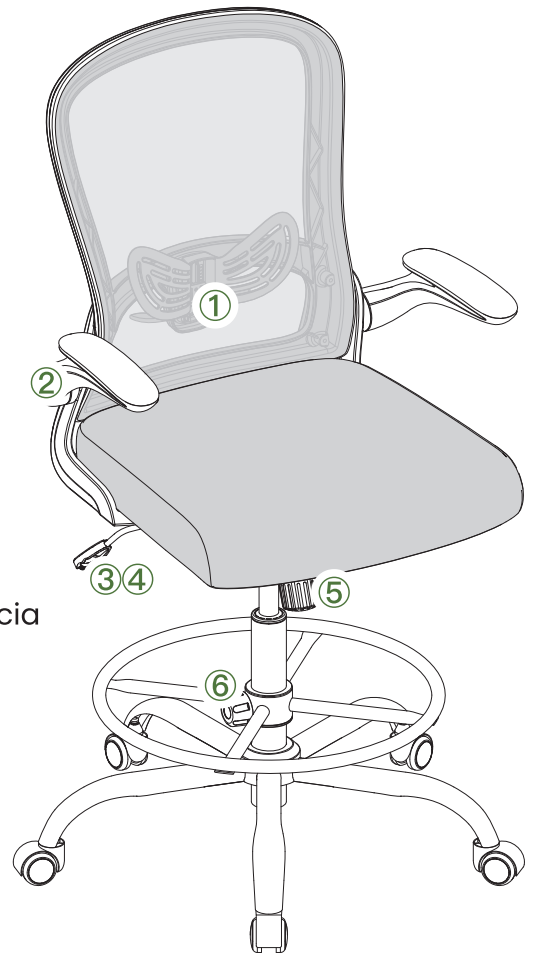

Ajuste de altura del soporte lumbar:

Agarre ambos lados del soporte para ajustarlo hacia arriba o hacia abajo.

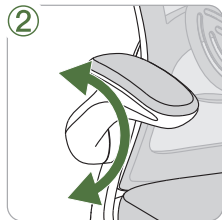
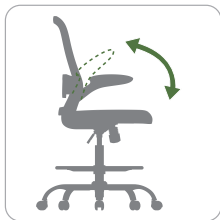

Apoyabrazos Plegable:

Baja el apoyabrazos para soporte o levántalo cuando no esté en uso.

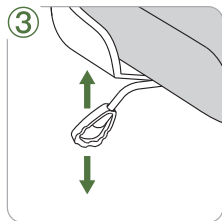
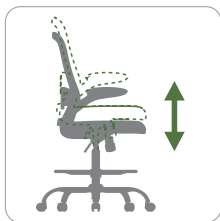

Ajuste de la altura del asiento:

Para levantar el asiento, levante el cuerpo de la silla y tire de la empuñadura hacia arriba. Para bajar el asiento, apoye el cuerpo en la silla y tire de la empuñadura hacia arriba.

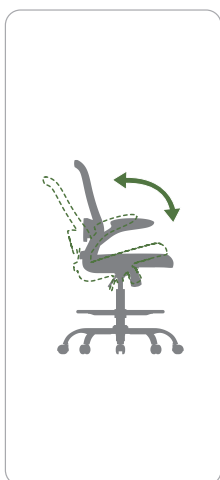

Función de balanceo del respaldo:

Tire de la empuñadura hacia fuera para activar la función de balanceo. La silla se balancea hacia adelante y hacia atrás con el usuario en lugar de estar bloqueada en una posición fija. Vuelva a colocar la empuñadura en su posición original para bloquearla.

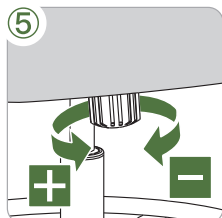

Ajuste del ángulo de inclinación del respaldo:

Gire la perilla [+] o [-] para ajustar la tensión del balanceo. Aumente para usuarios más pesados y disminuya para usuarios más ligeros.

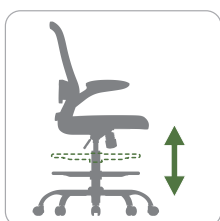

Ajuste de la altura del anillo del reposapiés:

Gire la perilla en sentido antihorario para desbloquear. Baje o suba el aro reposapiés a la posición deseada, luego gire la perilla en sentido horario para bloquear.

INFORMACIÓN IMPORTANTE DE SEGURIDAD



Uso en oficinas domésticas



Sólo (1) persona debe sentarse en la silla a la vez.



Siéntese en la silla con el peso centrado sobre la base.



Utilice la silla sólo en suelos nivelados.



No se suba a la silla ni la utilice como escalera o peldaño.



Sentarse en el reposabrazos puede provocar daños y lesiones.



Para evitar volcarse, no levante las piernas mientras inclina el respaldo.



No se sienta en el borde de la silla.

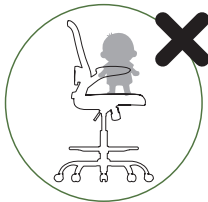

Los niños menores de 5 años no deben utilizar la silla cuando están solos.

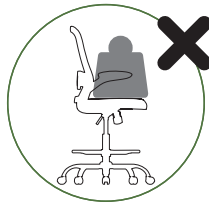

No coloque objetos pesados sobre la silla ni la utilice como carro.

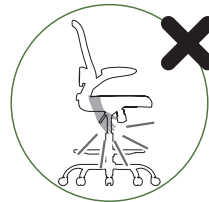

Mantenga las manos alejadas del mecanismo de elevación del asiento durante su funcionamiento.

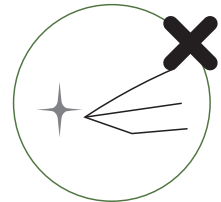

No utilice objetos con bordes afilados o ganchos cerca de la silla.

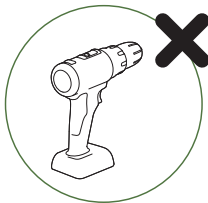

Utilice solo herramientas manuales. No utilice un taladro eléctrico.

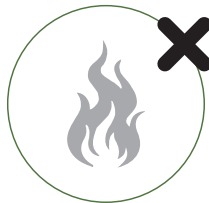

Mantenga la silla alejada de llamas y fuentes de calor.

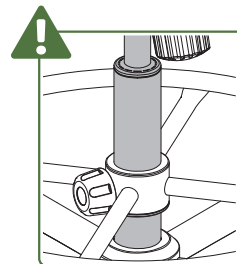

¡ADVERTENCIA! Sólo el personal cualificado puede sustituir o reparar los componentes de regulación de la altura del asiento con acumuladores de energía.

CUIDADO Y MANTENIMIENTO

- Se recomienda limpiar bien la silla de oficina por lo menos una vez al mes para mantener un buen estado y funcionalidad.
- Use una aspiradora para sacar toda la suciedad que se acumule en el asiento.
- Las ruedas se atorarán si no se les realiza un mantenimiento frecuente. Cepille las ruedas con agua y séquelas con un paño húmedo.
- Puede usar jabón y agua para limpiar cualquier suciedad que se haya solidificado en la superficie de las ruedas.
- Utilice un paño seco para terminar de limpiar o deje la silla de oficina en un lugar ventilado para que se seque al aire.
- La luz solar directa puede arruinar la silla de oficina a lo largo del tiempo, deteriorando las telas y materiales. Mantenga su silla de oficina lejos de la luz solar directa.
- Las condiciones de humedad pueden provocar la formación de moho en el tejido y/u óxido en las piezas metálicas. No guarde la silla de oficina en un ambiente húmedo.
- Tenga cuidado con las bebidas, comida o cualquier otro tipo de líquido cerca de su silla. Si se produce un derrame, limpie y elimine las manchas inmediatamente.
- Evite el uso de objetos afilados o cuchillas cerca de la silla de oficina que puedan causar daños.
- Si es posible, cubra la silla para protegerla de la suciedad y el polvo.
- **Examine la silla y vuelva a apretar todos los sujetadores cada 6 meses para asegurarse de que estén seguros, incluidos los que conectan el asiento, el respaldo y el mecanismo de la silla.**