

ASSEMBLY INSTRUCTIONS

ITEM#: OF1601

Important Safety Instructions:

- Please read all instructions before beginning assembly
- Please make sure receive all the parcels to start the assembly
- For your safety and convenience, assembly by two people is recommended
- Use the parts and hardware lists to identify and separate each of the components included
- Save all packing materials until assembly is completed to avoid the accidental discarding of smaller parts or hardware

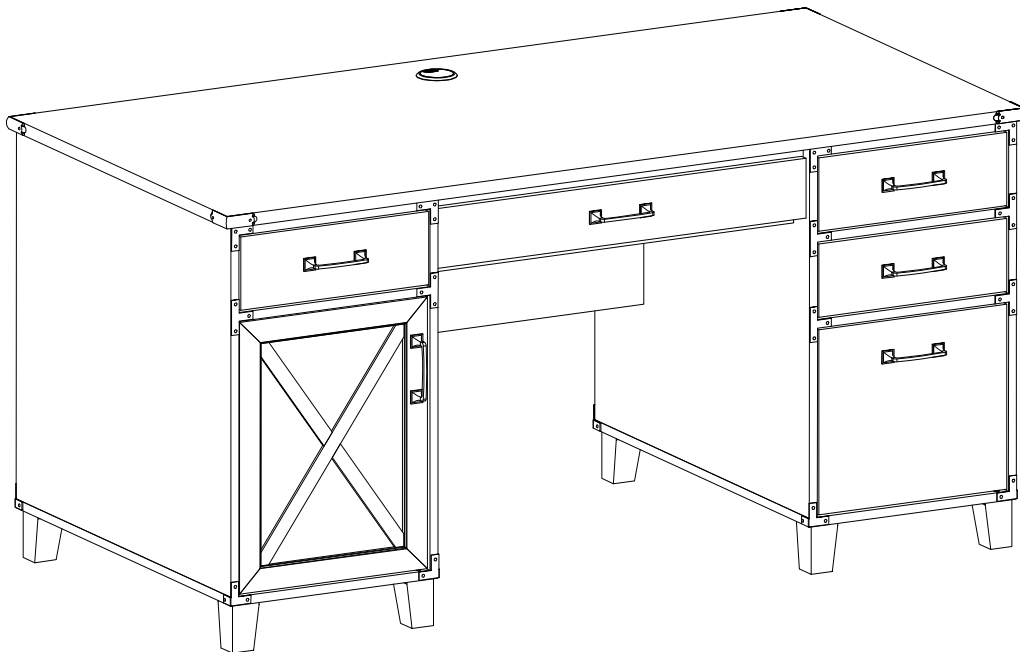







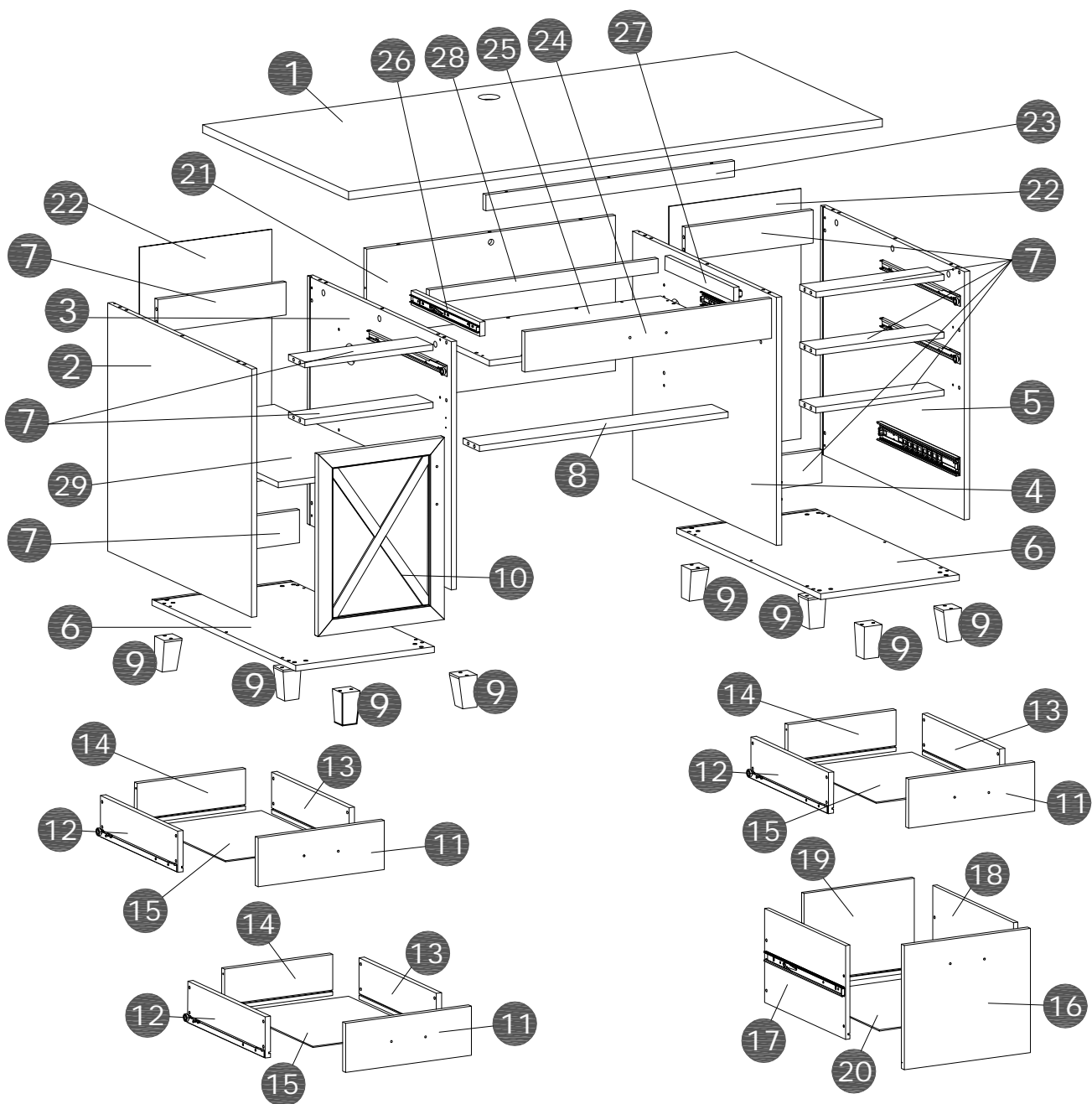

THANK YOU FOR PURCHASING

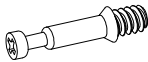

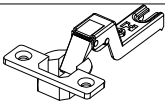
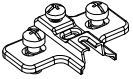

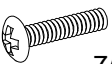

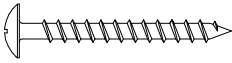
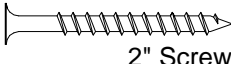
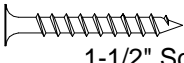
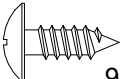
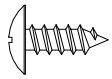
PARTS LIST

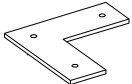
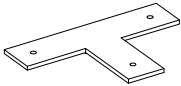
① X1	② X1	③ X1	④ X1	⑤ X1
⑥ X2	⑦ X9	⑧ X1	⑨ X8	⑩ X1
⑪ X3	⑫ X3	⑬ X3	⑭ X3	⑮ X3
⑯ X1	⑰ X1	⑱ X1	⑲ X1	⑳ X1
㉑ X1	㉒ X2	㉓ X1	㉔ X1	㉕ X1
㉖ X1	㉗ X1	㉘ X1	㉙ X1	

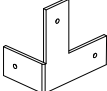
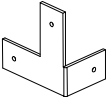
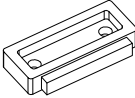
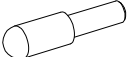
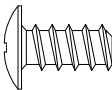
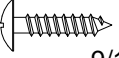
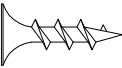

HARDWARE LIST

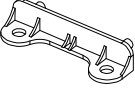
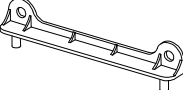
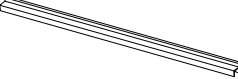
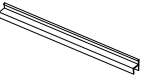
Name	Part	Qty.	Spare
A		33	1
B		33	1
C		48	1
D		2	
E		2	
F		6	
G	 7/8" Screw	10	1
H	 1" Screw	2	1
I		1	
J	 1-7/8" Screw	3	
K	 2" Screw	32	1
L	 1-1/2" Screw	22	1
M	 9/16" Screw	16	
N	 1/2" Screw	16	1
O		54	2
P		4	
Q		6	

Name	Part	Qty.	Spare
R	 5/6" nail	8	2
S		4	
T		4	
U		4	
V		1	
W		4	
X		2	
Y	 9/16" Screw	2	
Z		8	
AA		2	
BB	 Bumper Ø10x4mm	2	
CC		6	
DD		2	
EE		2	
FF		1	
GG		1	

STEP 1

C x18pcs 

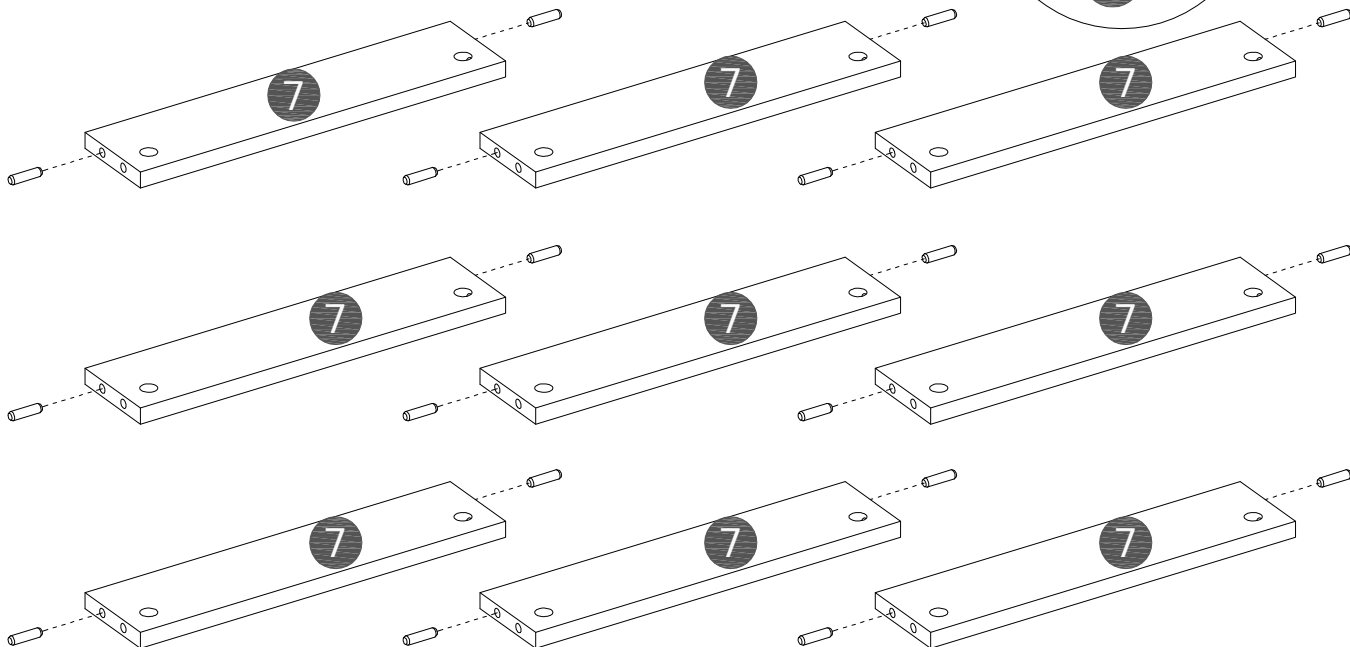
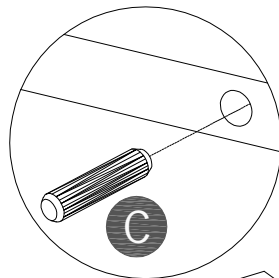

STEP 2

C x8pcs 

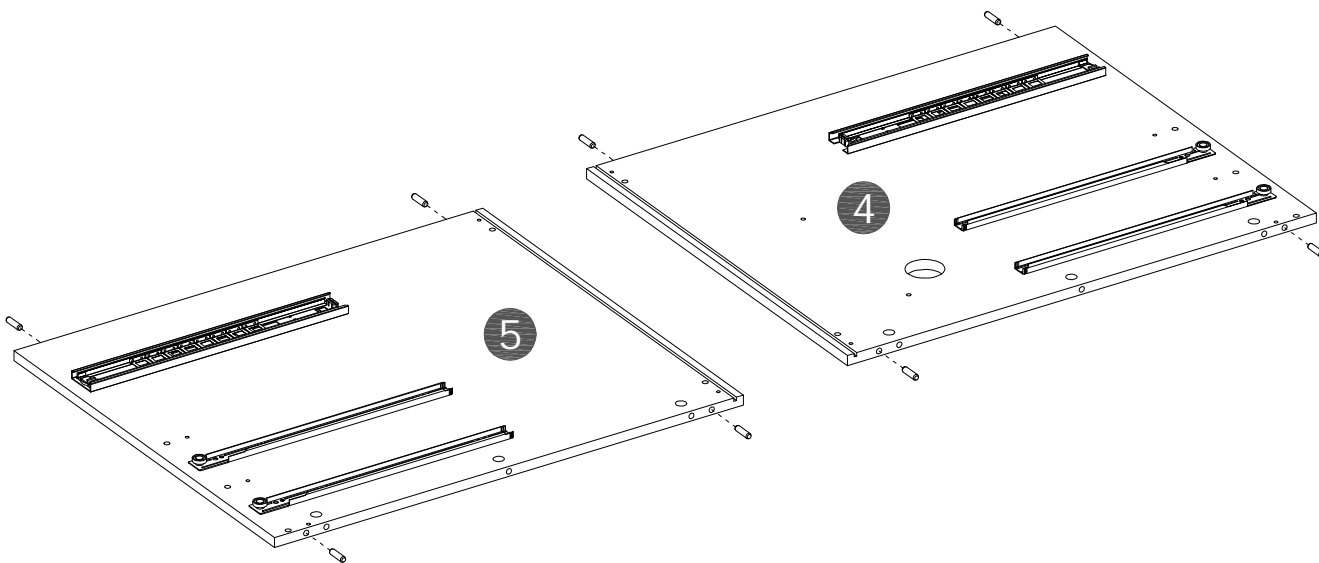
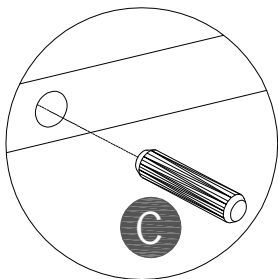

STEP 3

A x10pcs

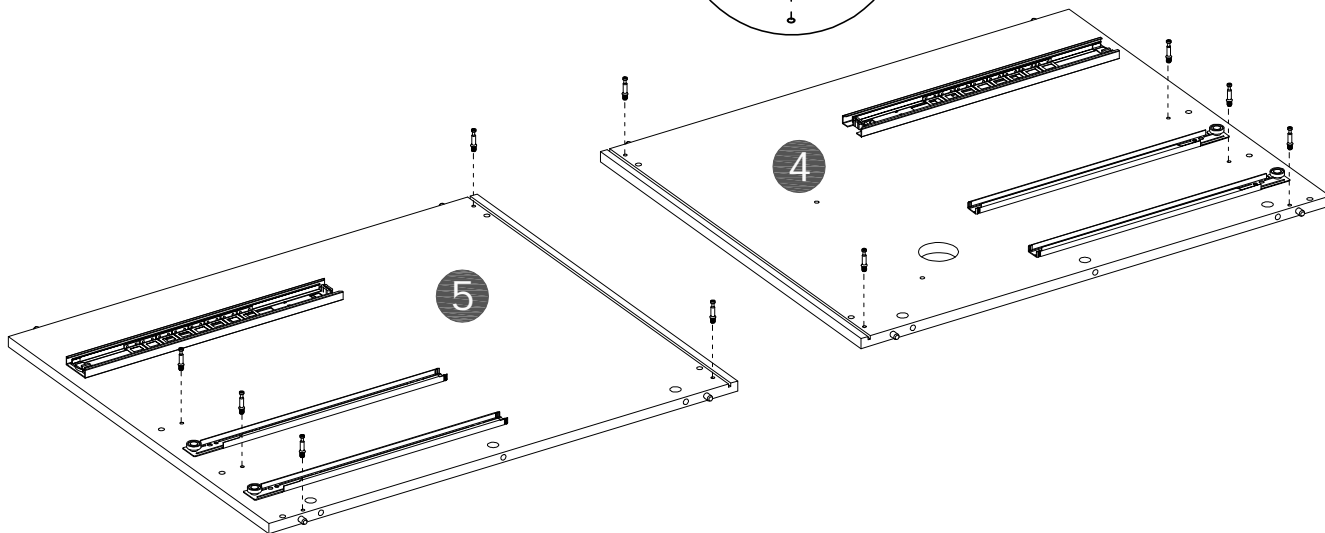
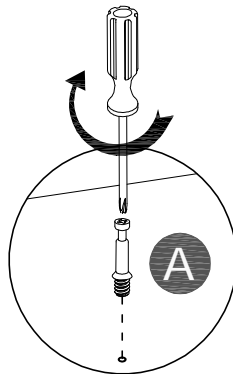
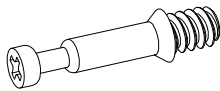

STEP 4

B x5pcs

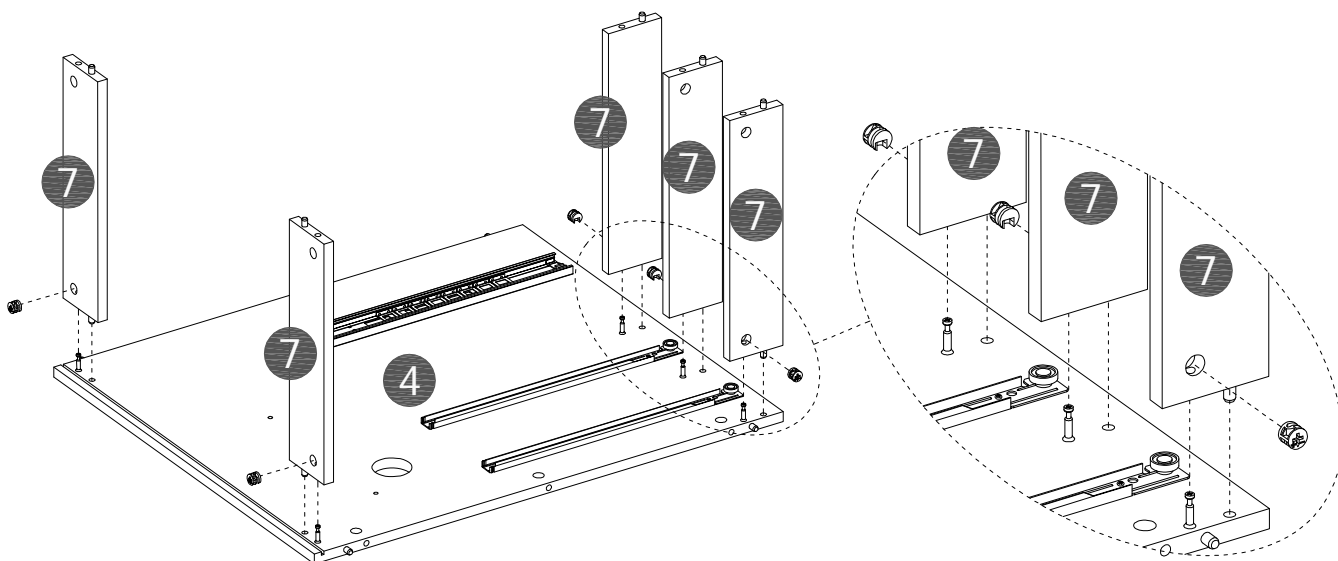
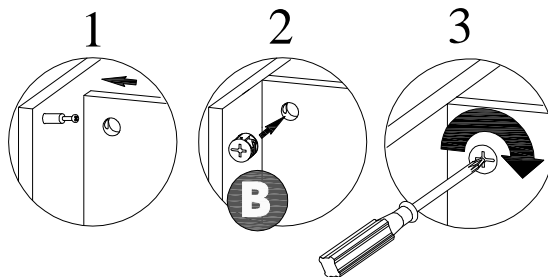

STEP 5

B x5pcs

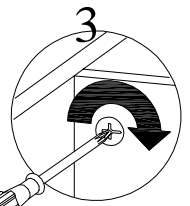
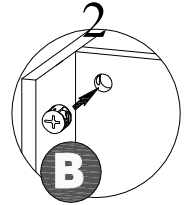
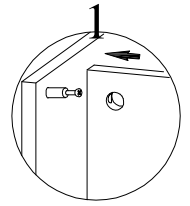
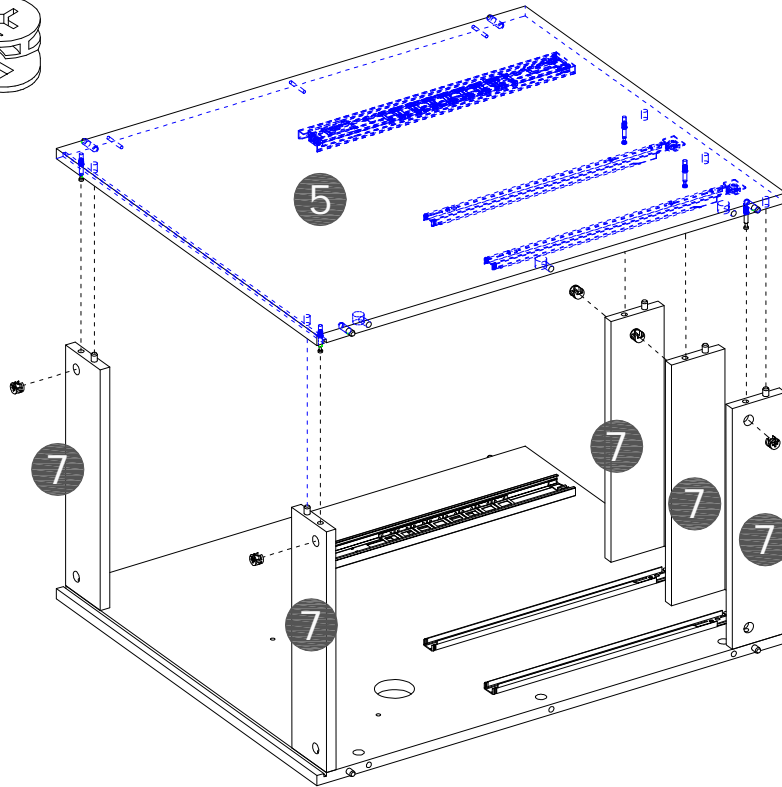

STEP 6

K x8pcs

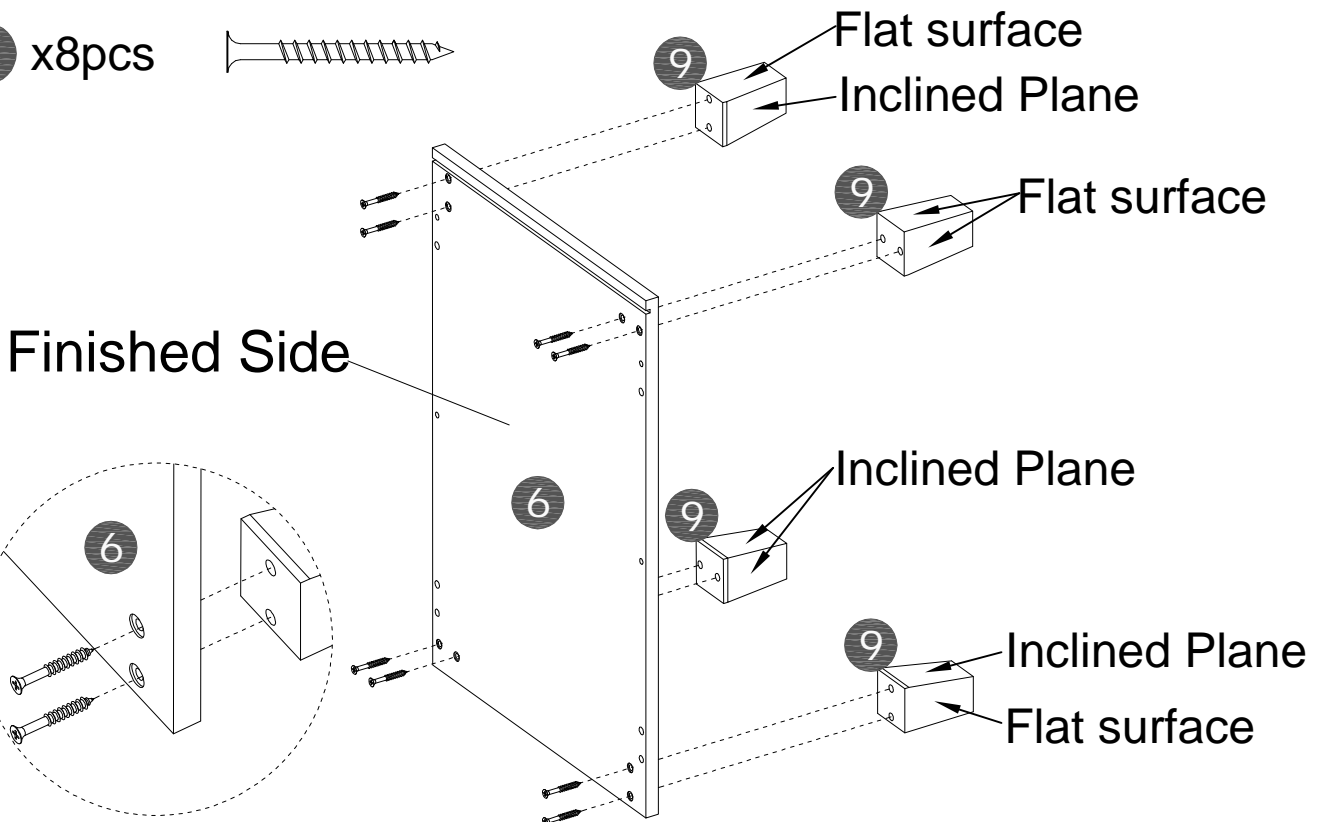
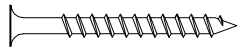

STEP 7

K x6pcs

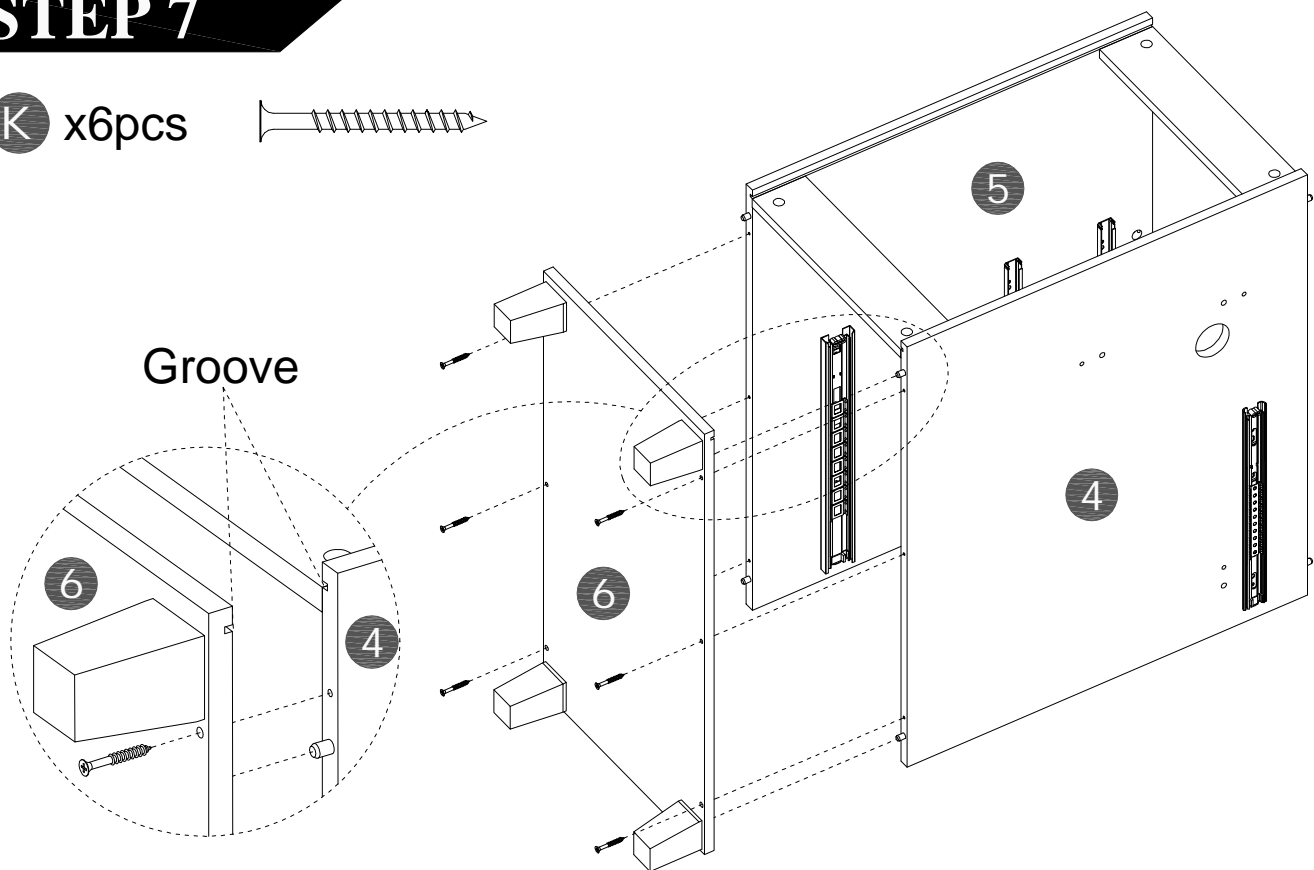
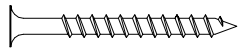

STEP 8

T x1pcs

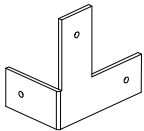

U x1pcs

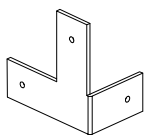

O x 6pcs



A x1pc

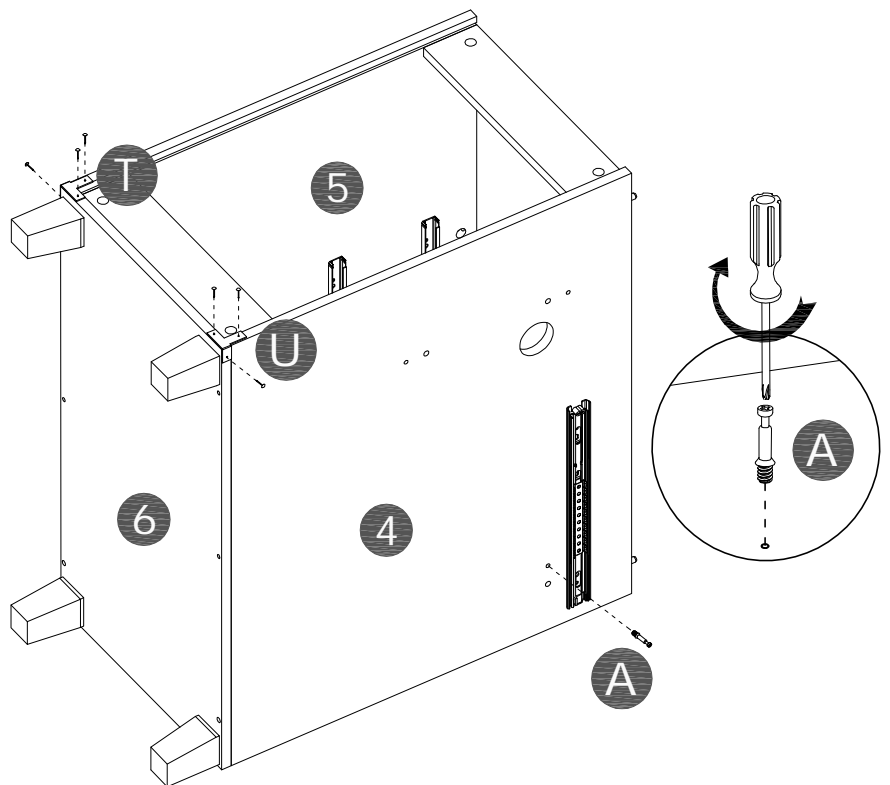
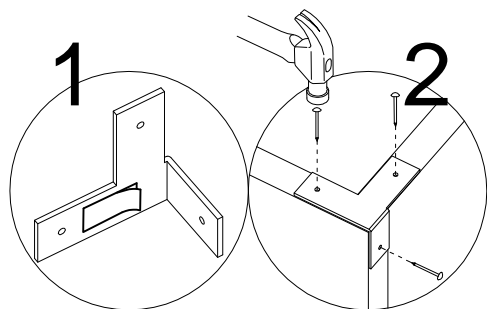
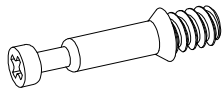

Peel off the adhesive sticker's protective paper and bond it onto the designated position before secure with nails.

STEP 9

T x1pcs

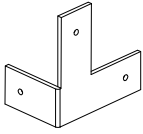

U x1pcs

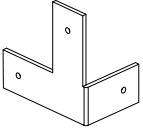

O x6pcs

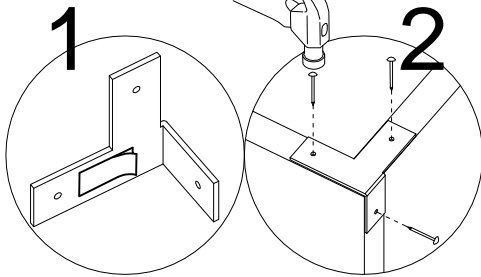

With assistant carefully flip the other side.

Peel off the adhesive sticker's protective paper and bond it onto the designated position before secure with nails.

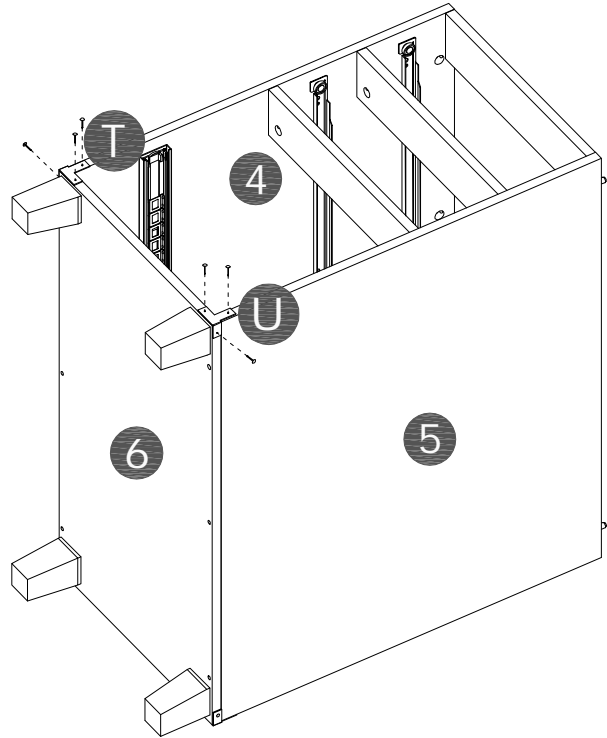

STEP 10

P x2pcs

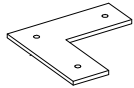

Q x4pcs

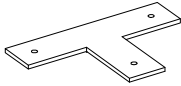

O x18pcs

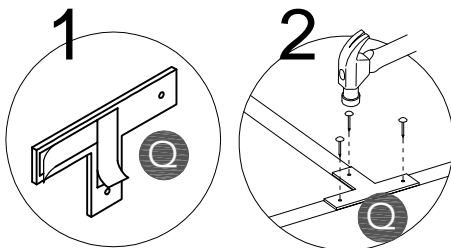
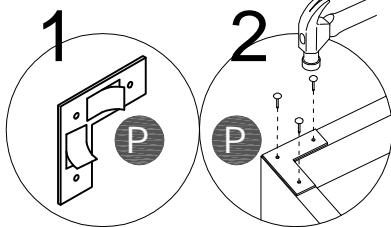

Peel off the adhesive sticker's protective paper and bond it onto the designated position before secure with nails.

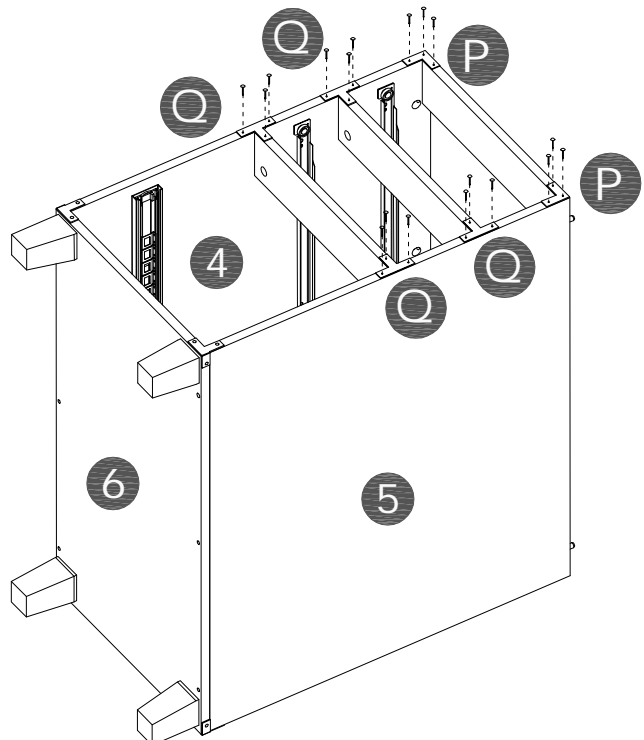

STEP 11

C x8pcs

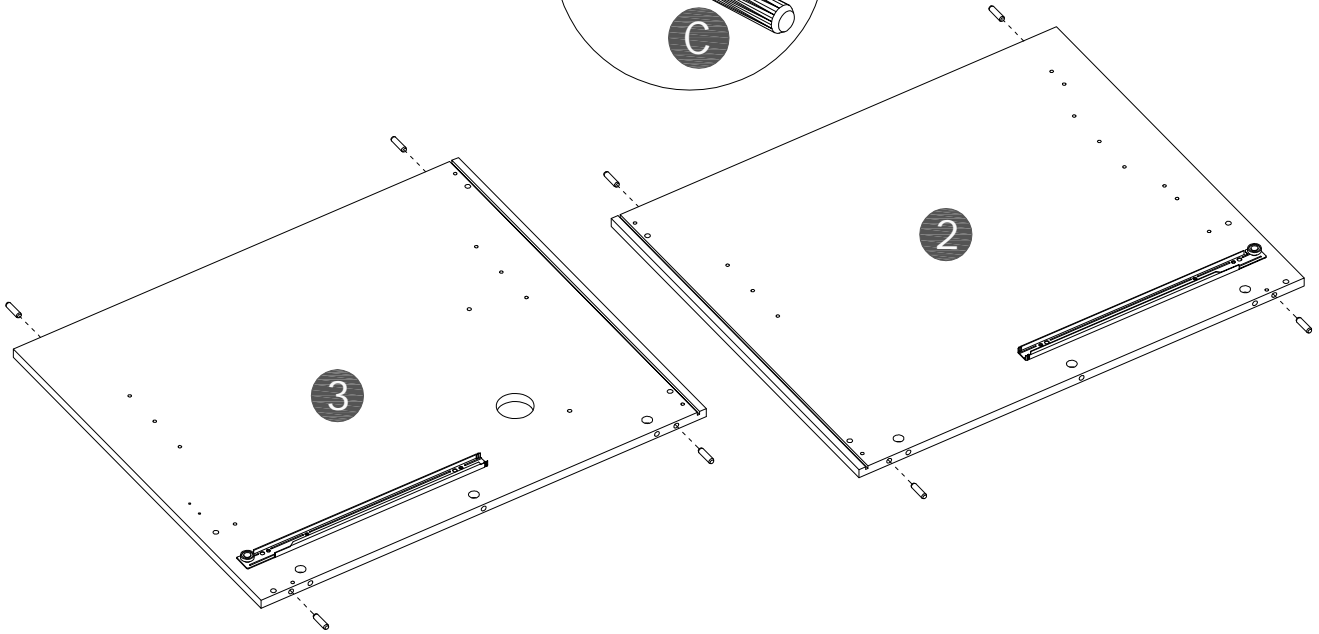
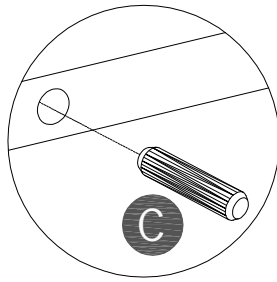
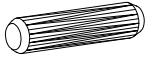

STEP 12

A x8pcs

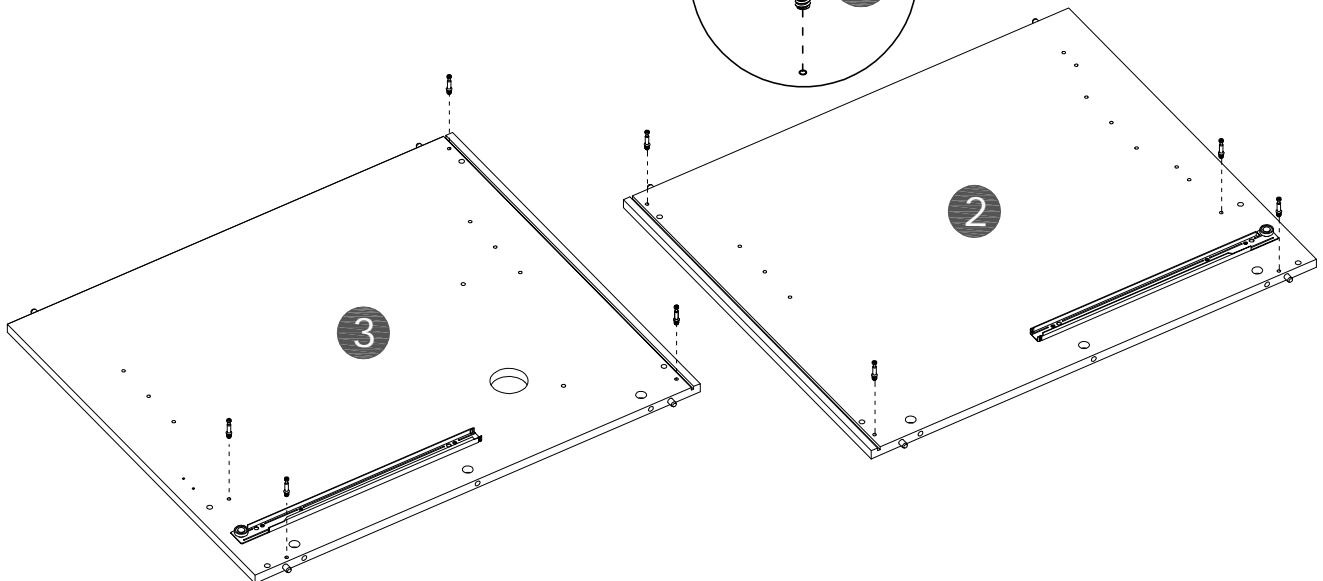
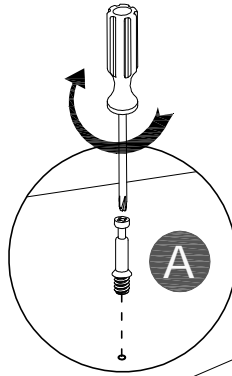
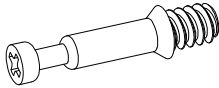

STEP 13

E x2pcs

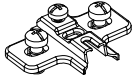

Y x2pcs



V x1pcs

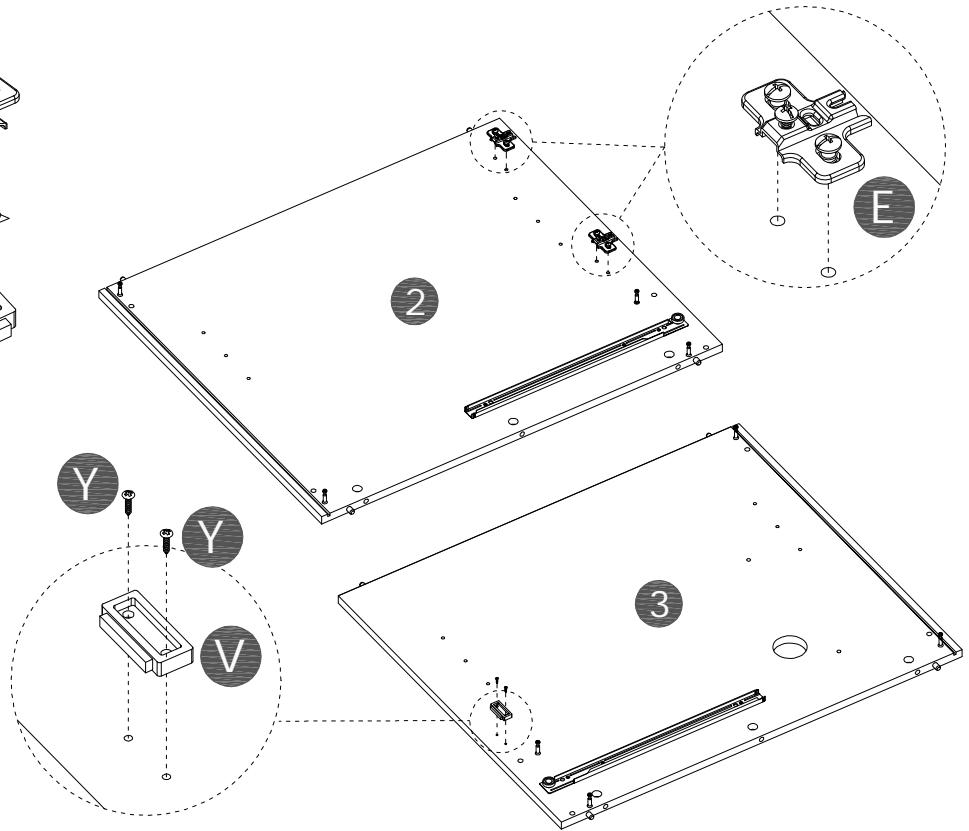
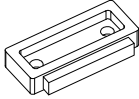

STEP 14

B x4pcs

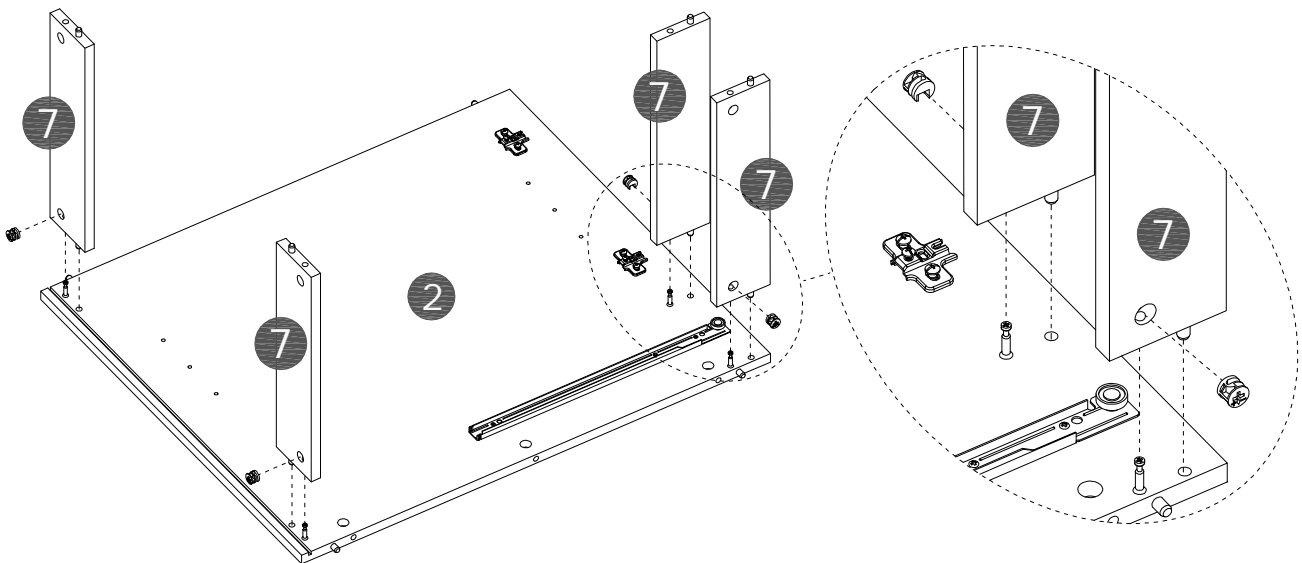
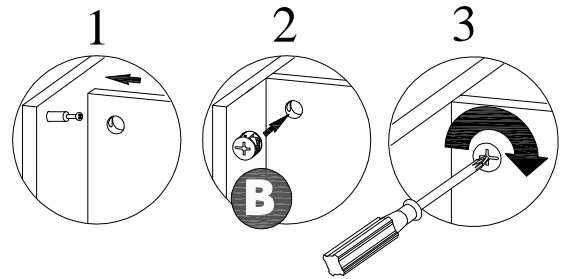

STEP 15

B x4pcs

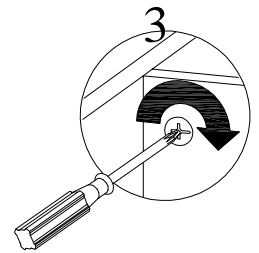
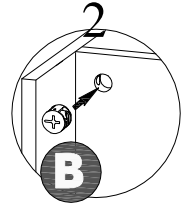
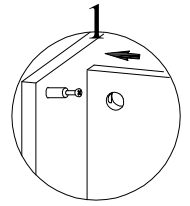
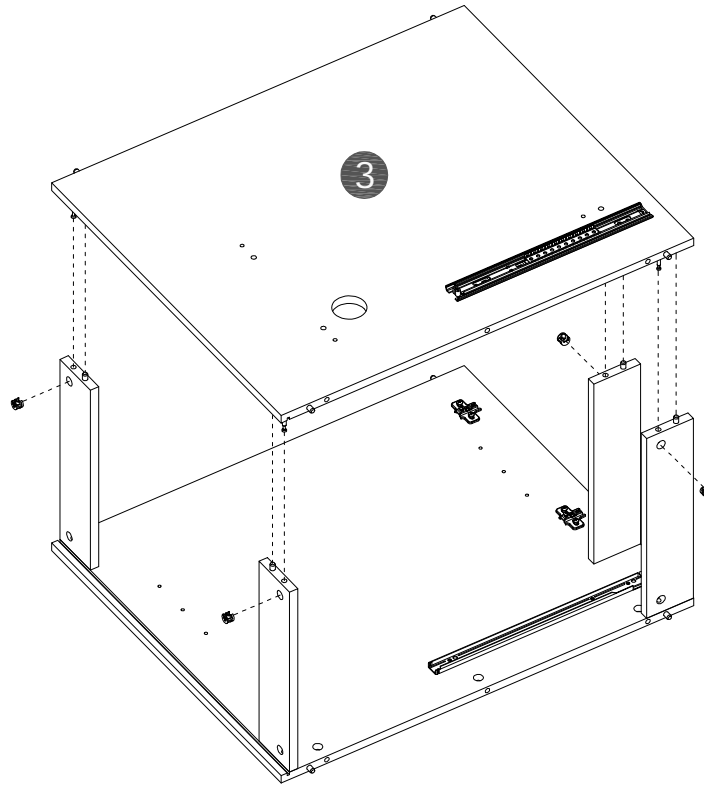
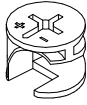

STEP 16

K x8pcs

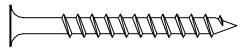

Finished Side

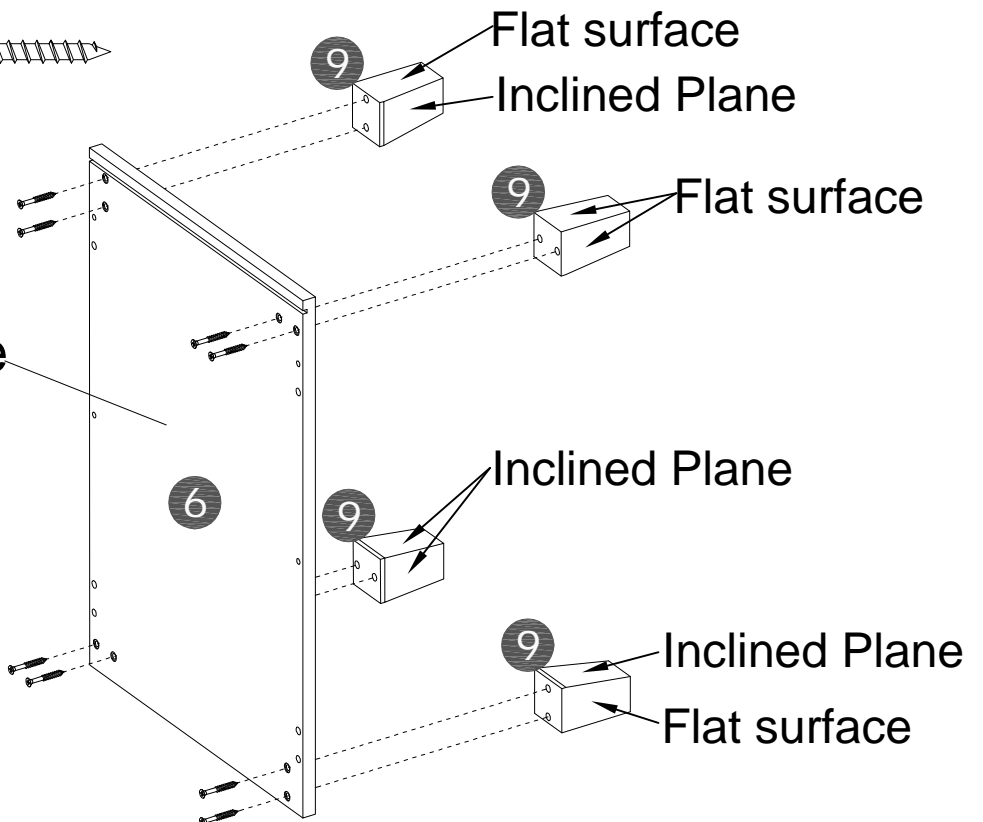
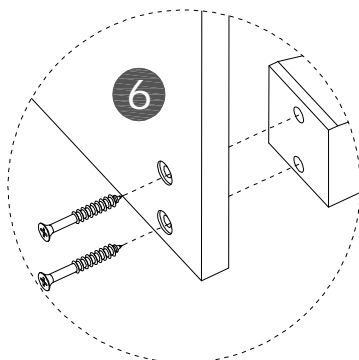

STEP 17

K x6pcs

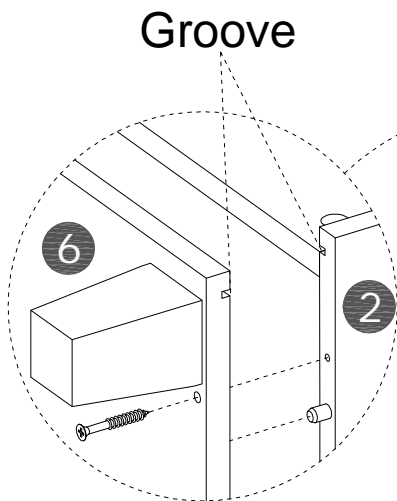
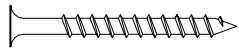

Groove

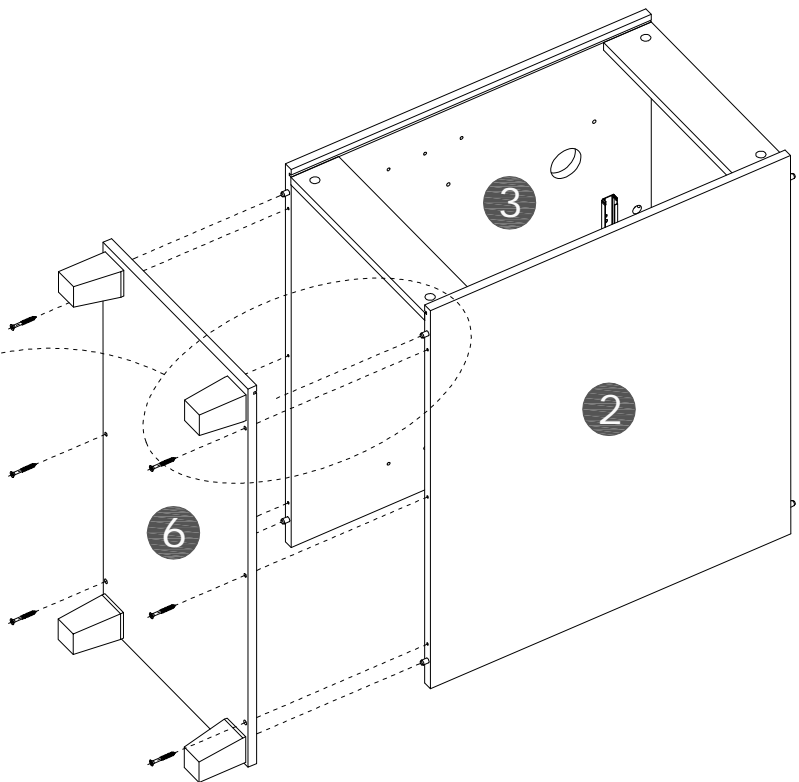

STEP 18

T x1pcs

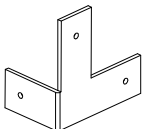

U x1pcs

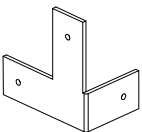

O x6pcs

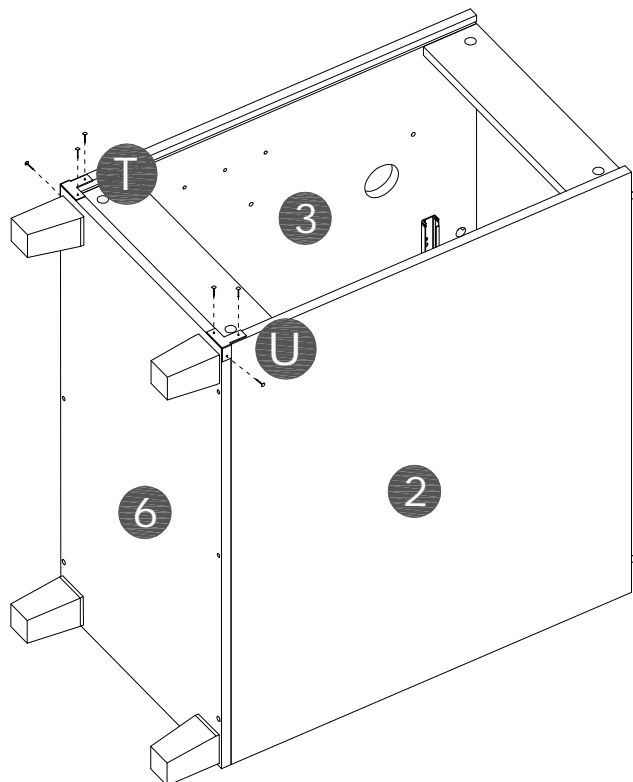
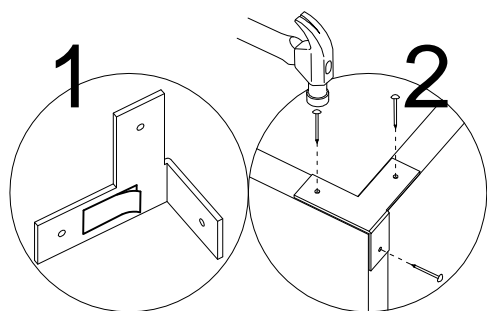

Peel off the adhesive sticker's protective paper and bond it onto the designated position before secure with nails.

STEP 19

T x1pcs

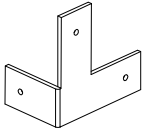

U x1pcs

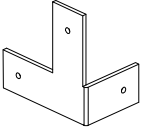

O x6pcs

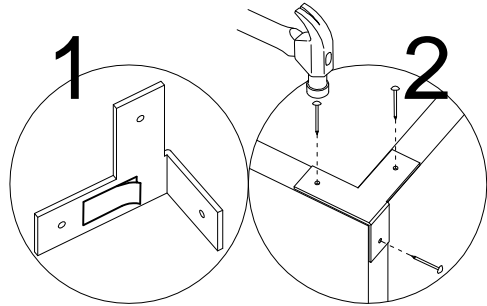

With assistant carefully flip the other side.

Peel off the adhesive sticker's protective paper and bond it onto the designated position before secure with nails.

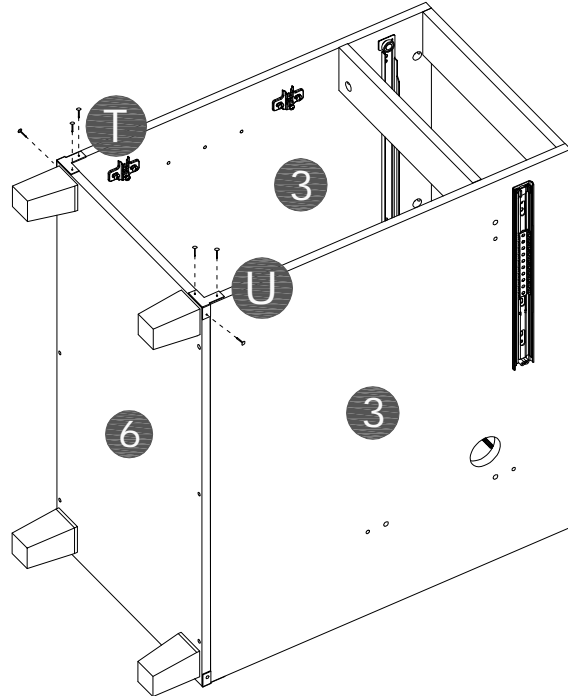

STEP 20

P x2pcs

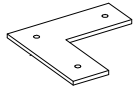

Q x2pcs

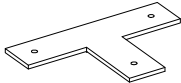

O x12pcs



A x1pc

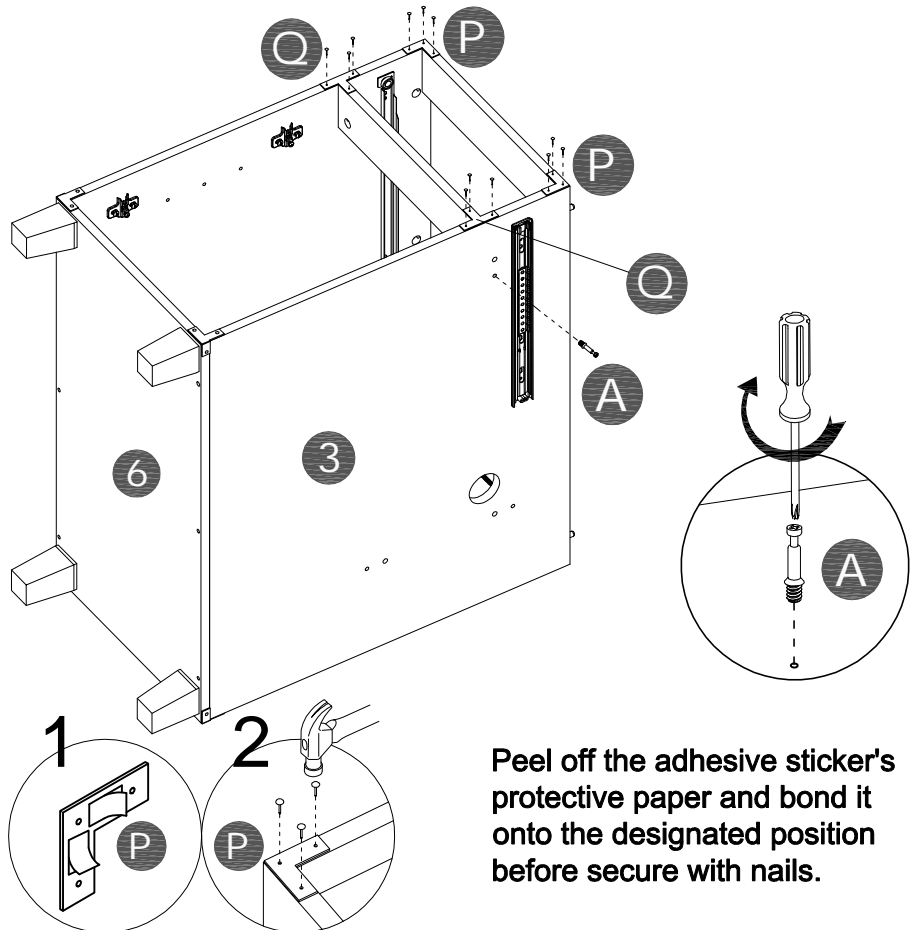
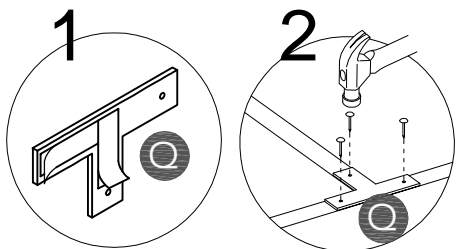
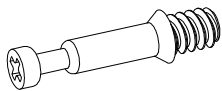

Peel off the adhesive sticker's protective paper and bond it onto the designated position before secure with nails.

STEP 21

C x8pcs 

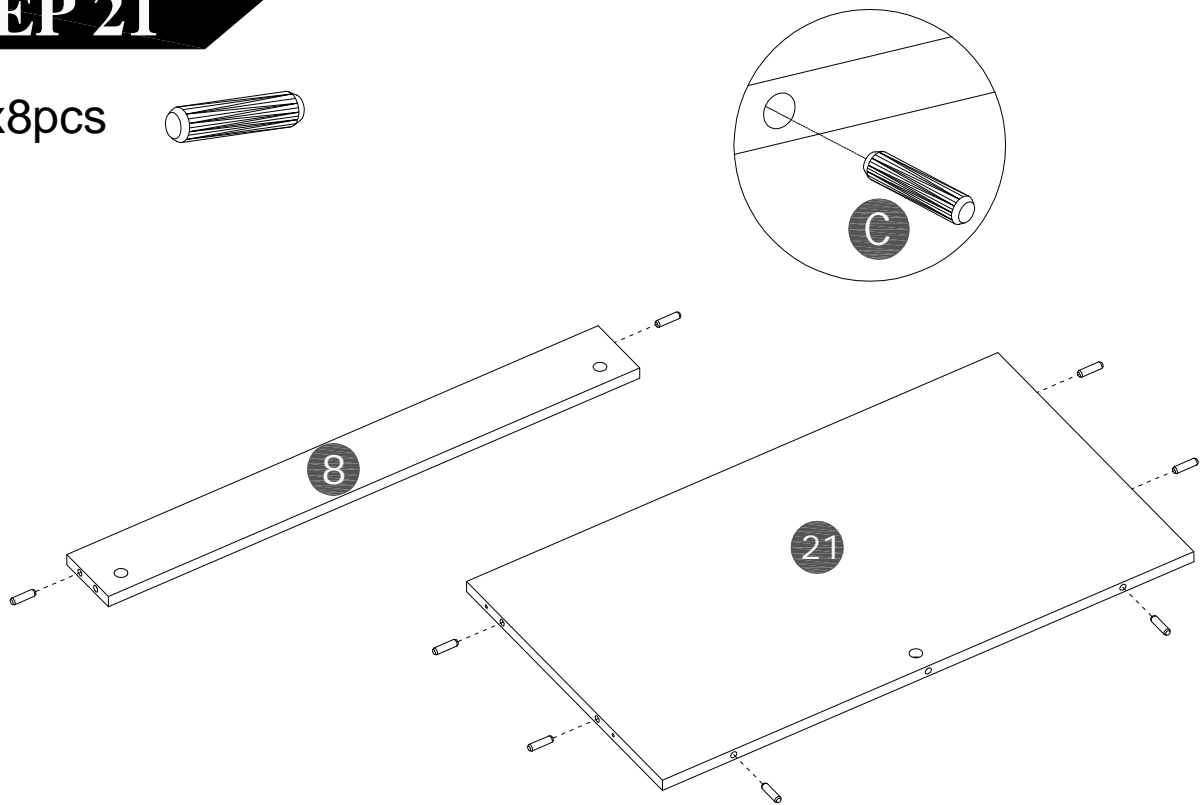

STEP 22

K x2pcs 

B x1pc 

Holes 15 mm in diameter
face the other side

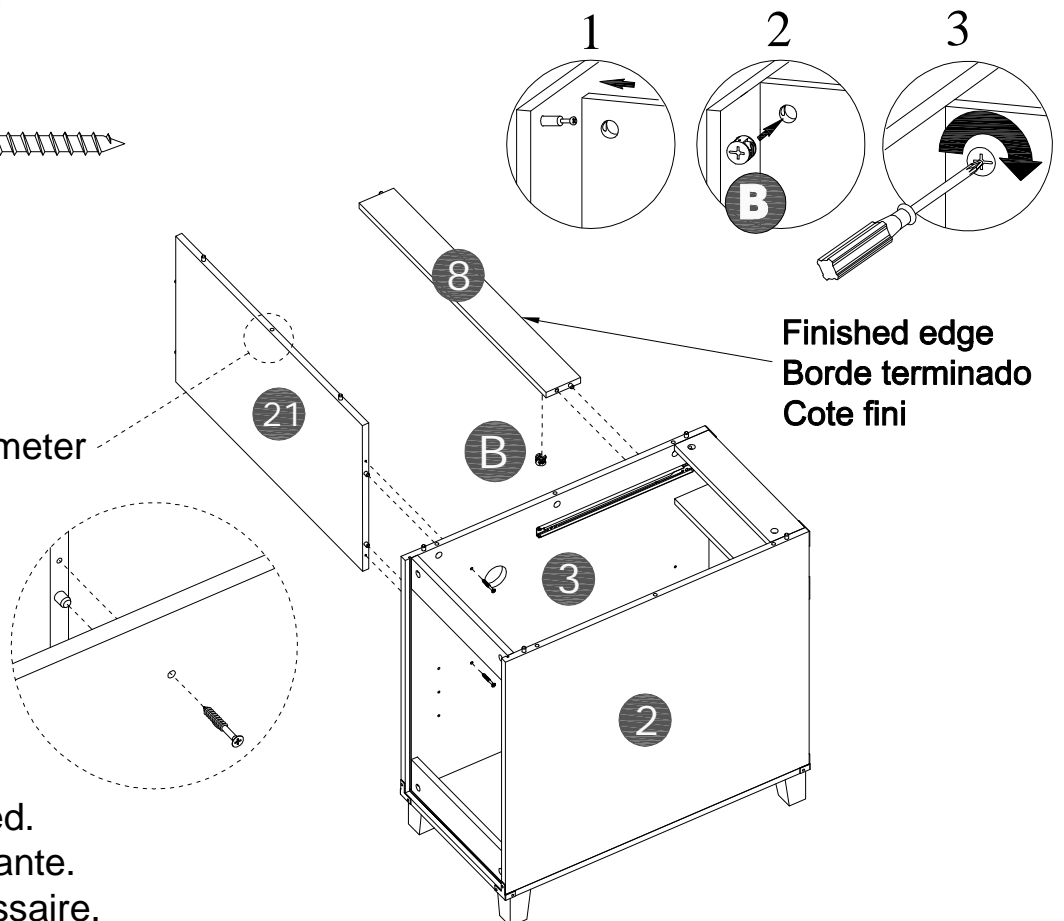

An assistant is required.
Es necesario un ayudante.
Un assistant est nécessaire.

STEP 23

K x2pcs

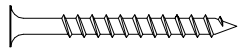

B x1pc

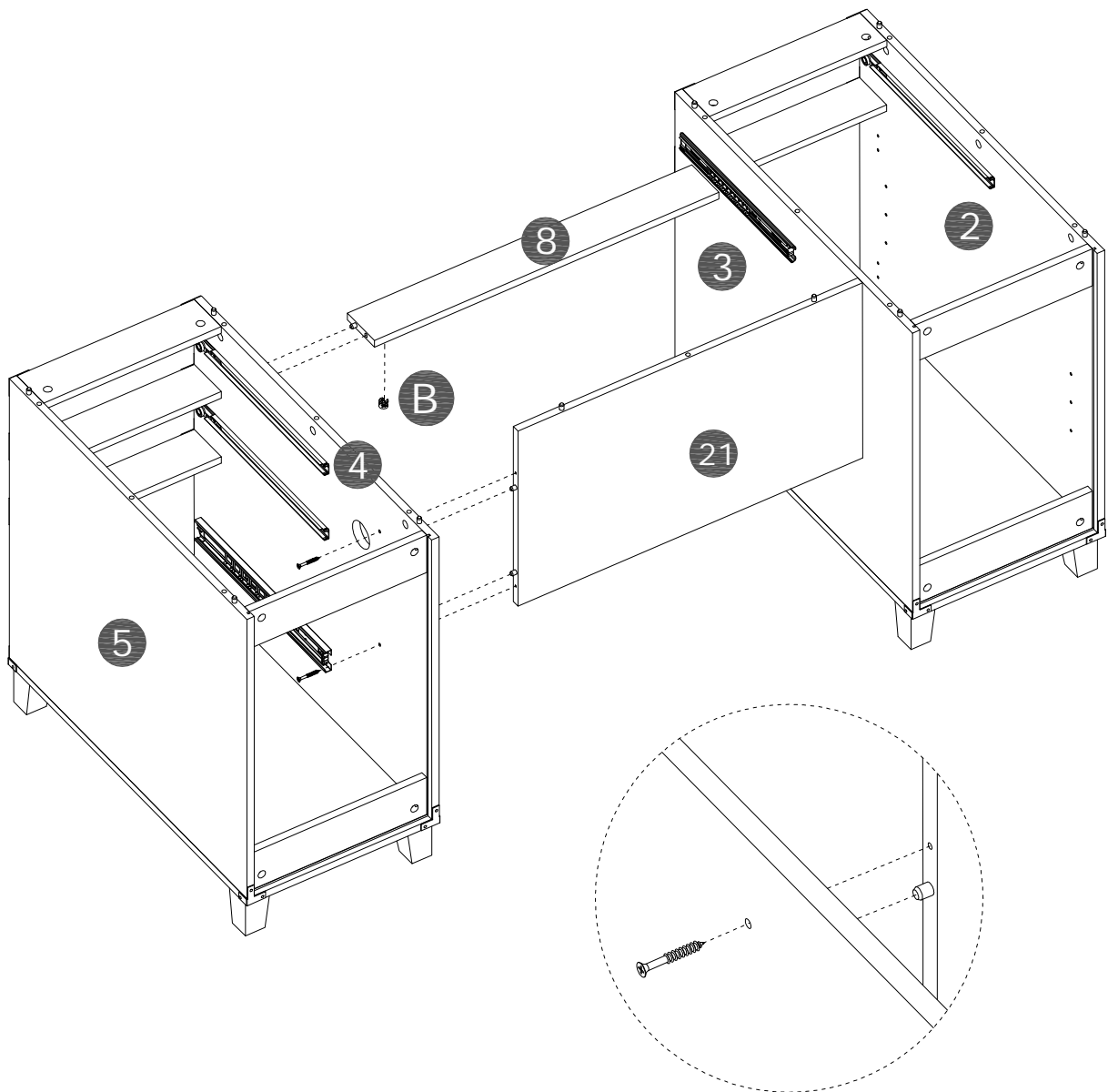
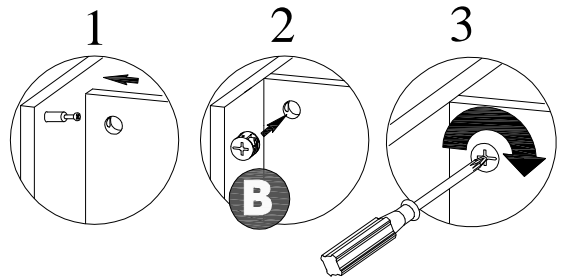

An assistant is required.
Es necesario un ayudante.
Un assistant est nécessaire.

STEP 24

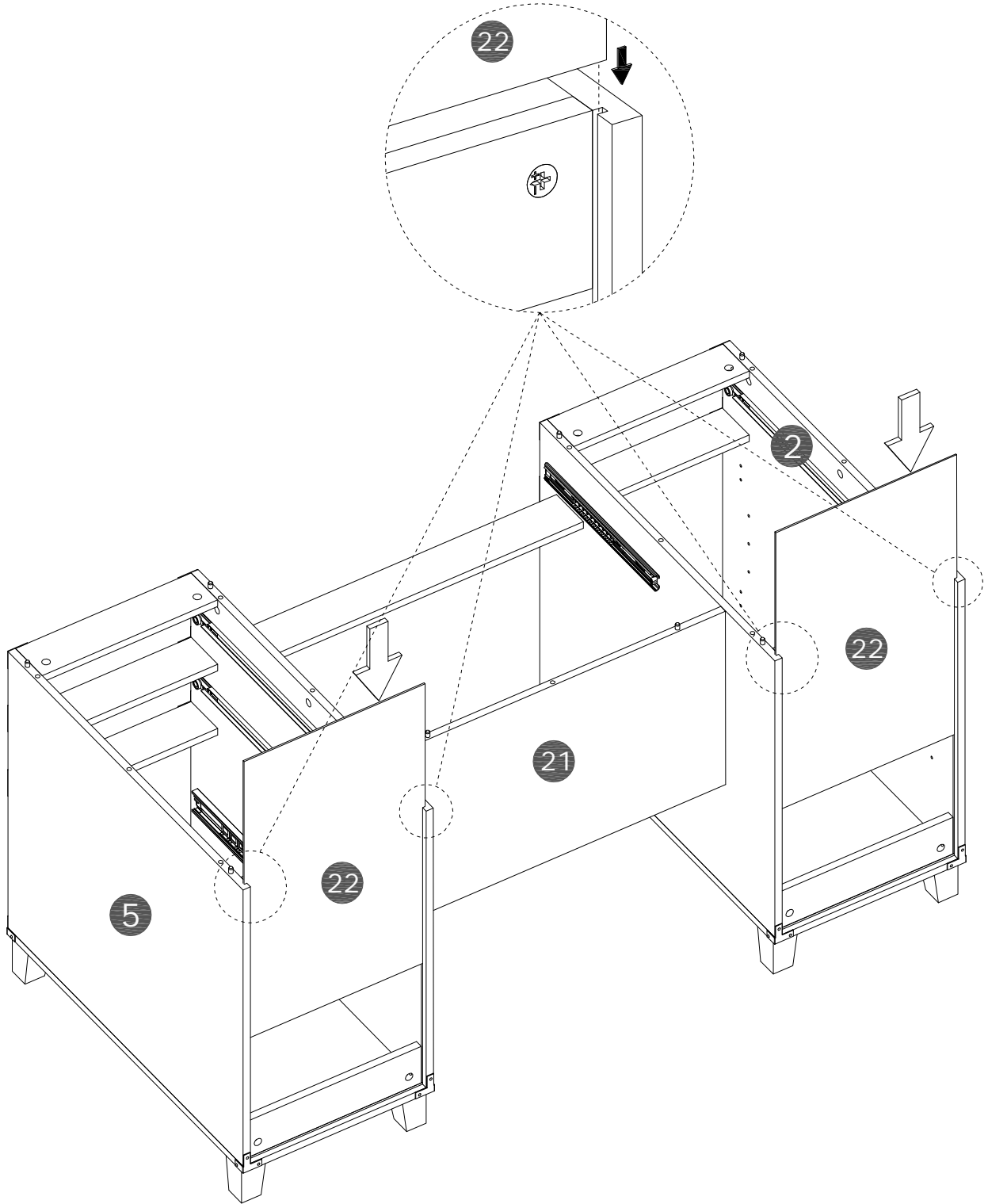

STEP 25

J x3pcs 

A x13pcs 

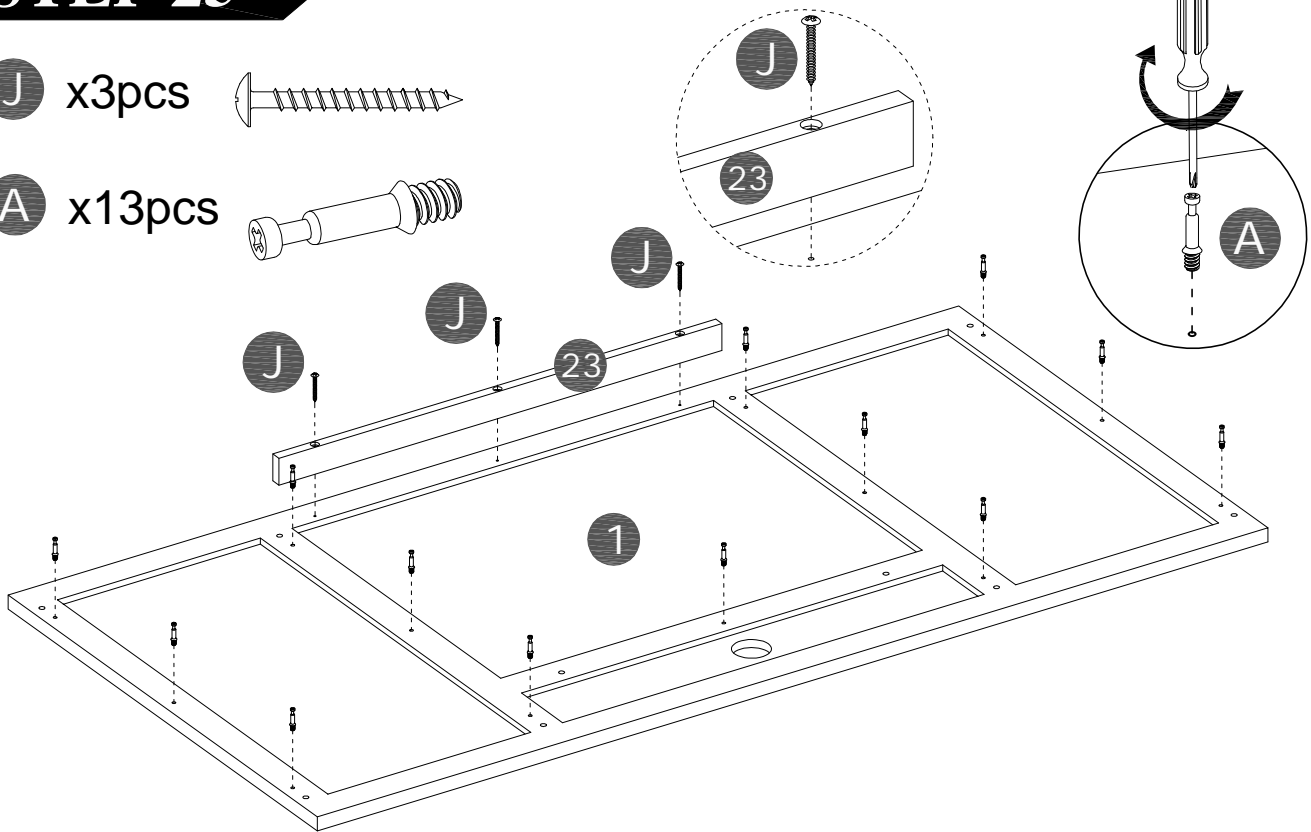

STEP 26

B x13pcs 

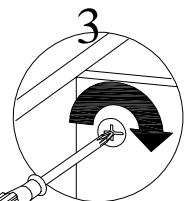
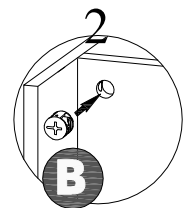
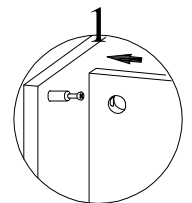
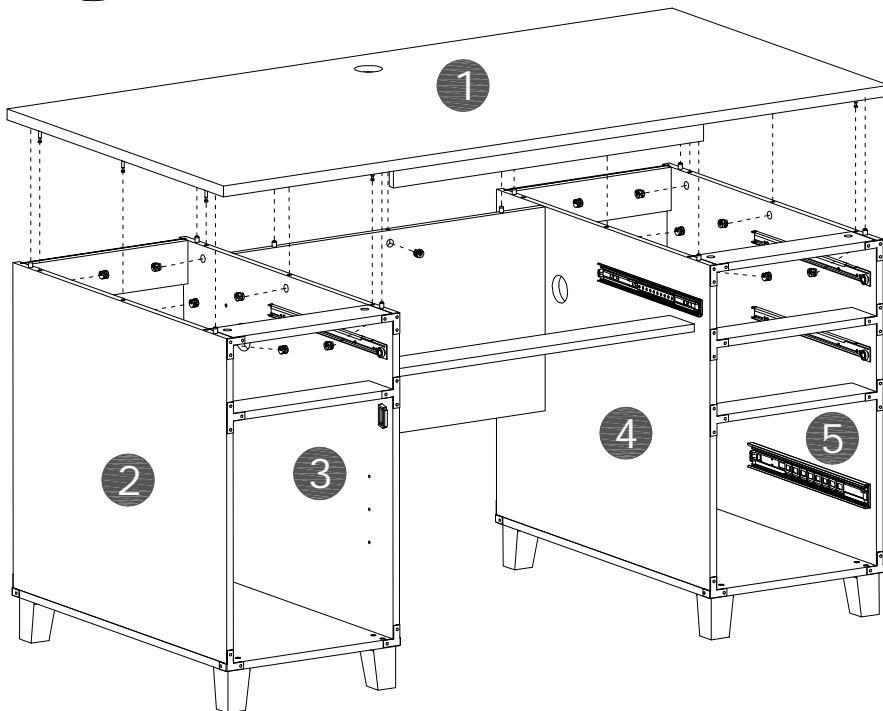

STEP 27

R x8pcs

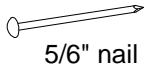

S x4pcs

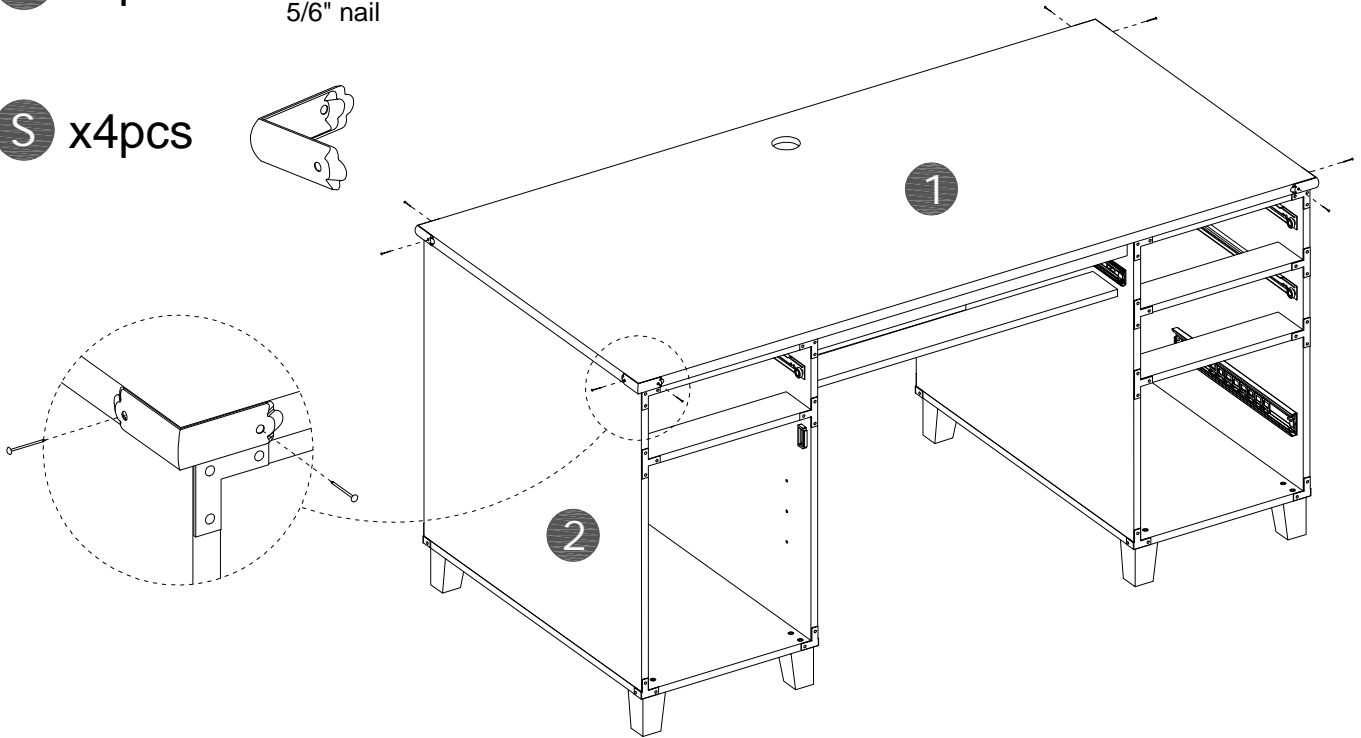
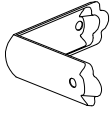

STEP 28

I x1pcs

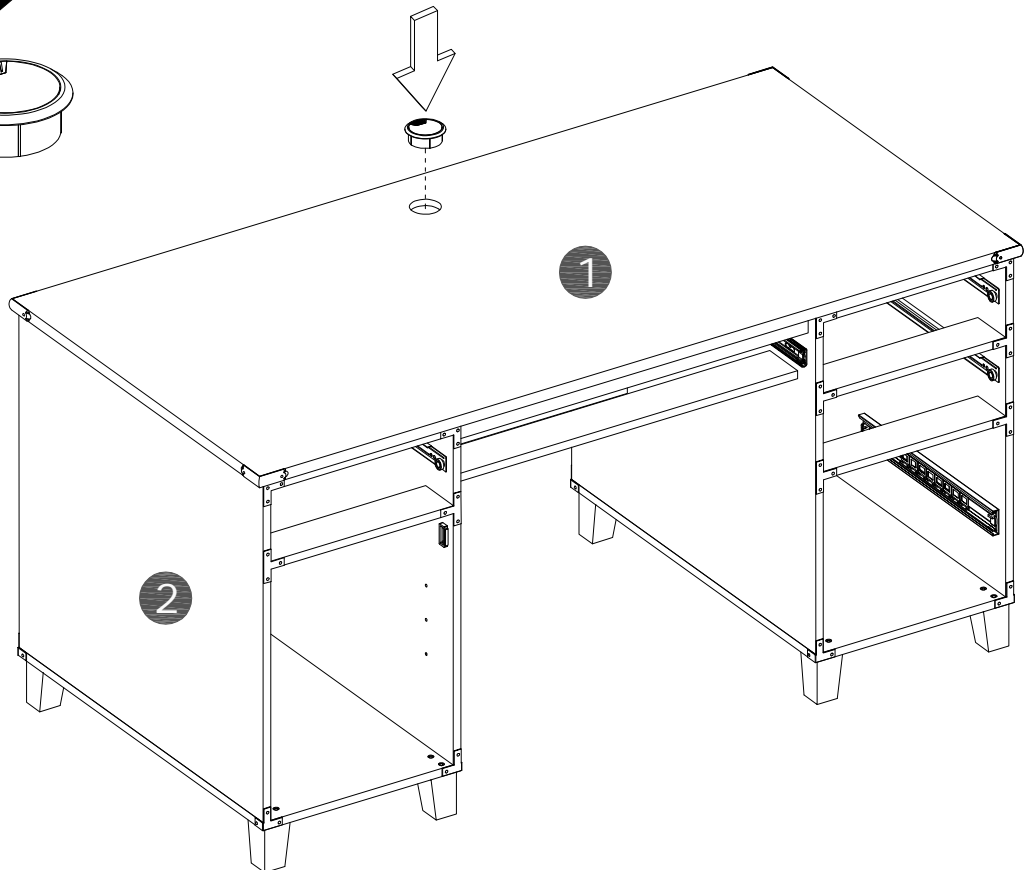
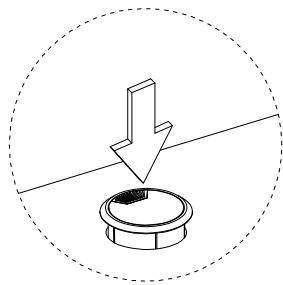
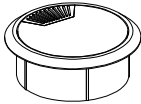

STEP 29

W x4pcs

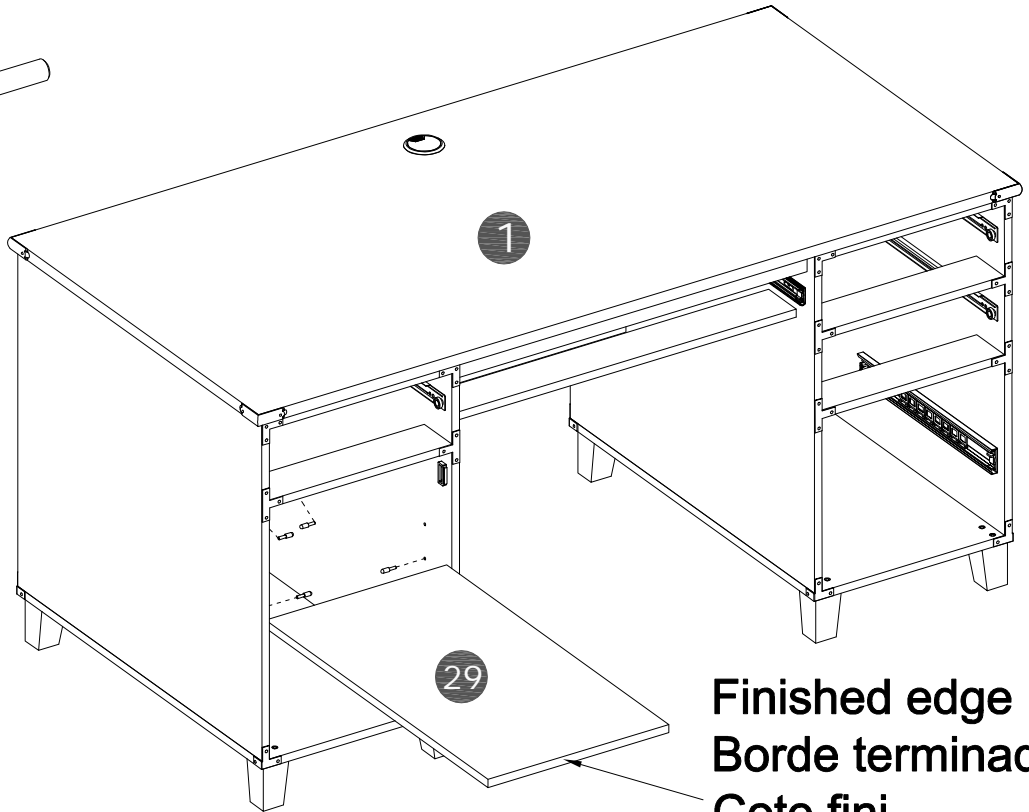
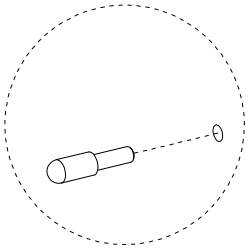
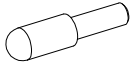

STEP 30

D x2pcs

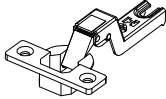

Z x4pcs

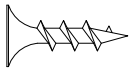

F x1pcs



H x2pcs

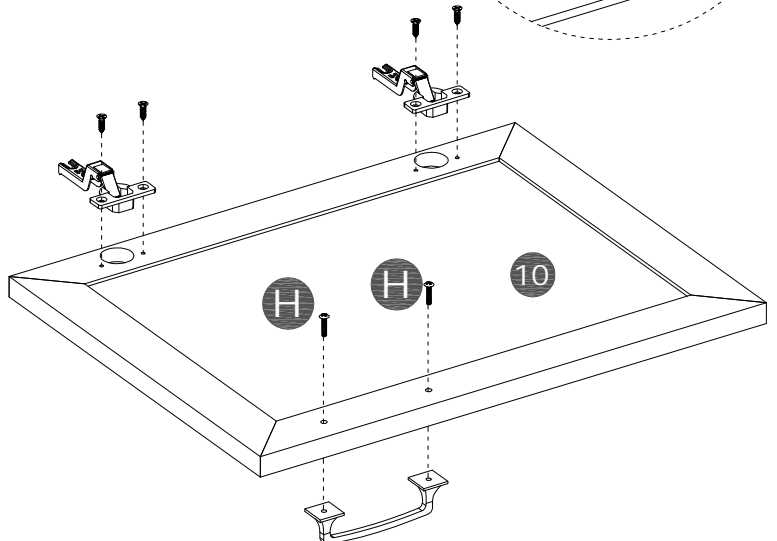
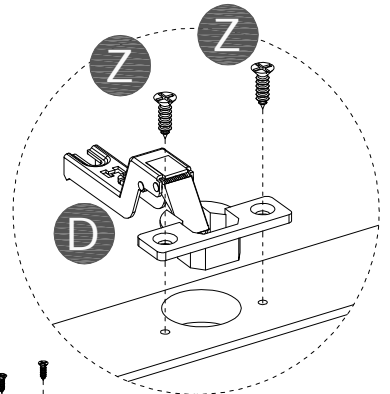

WARNING

Caution, Storing electronic equipment may result in equipment overheating.
Shelves located behind doors are not intended for storing electronic equipment. Placing electronic equipment in this area may result in equipment overheating

STEP 31

Installation

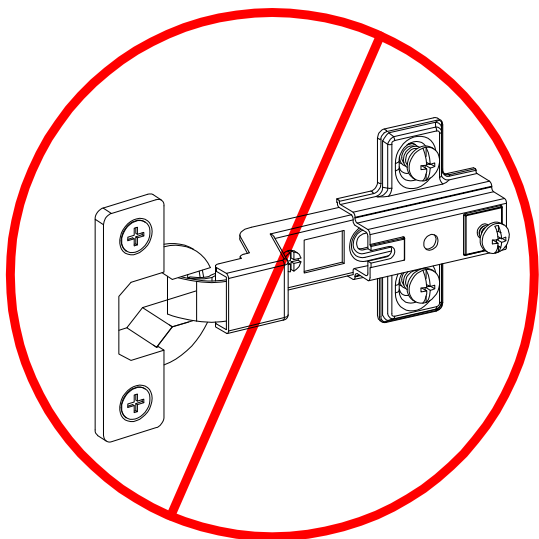

**DO NOT Insert
Hinge beneath mount**

Adjustment

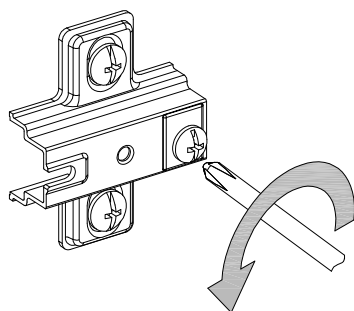
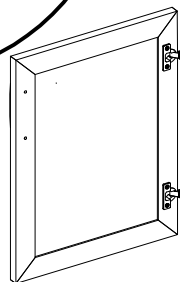
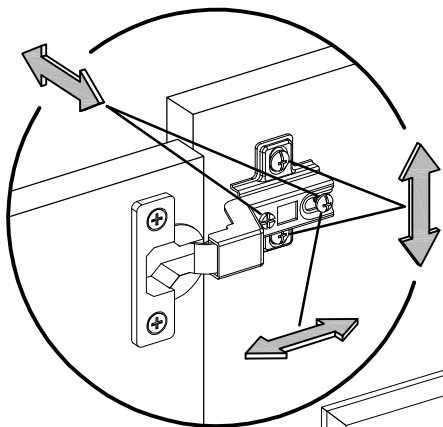

1

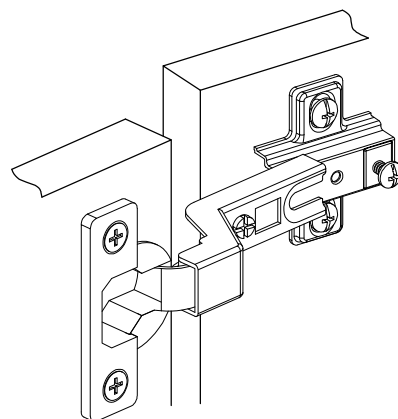

2

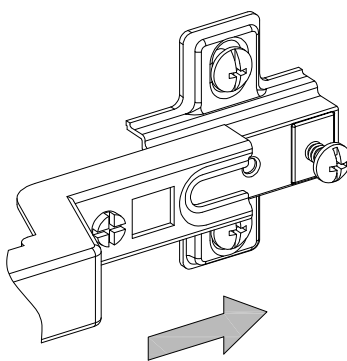

3

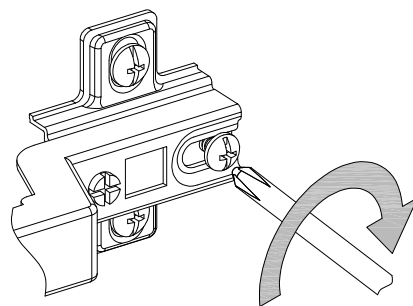

4

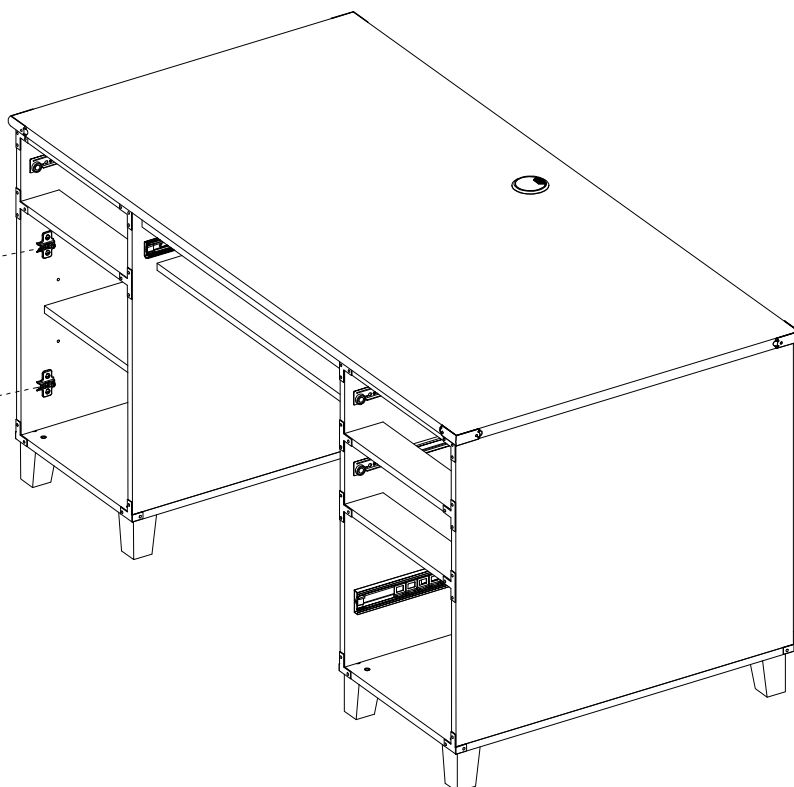

STEP 32

C x6pcs

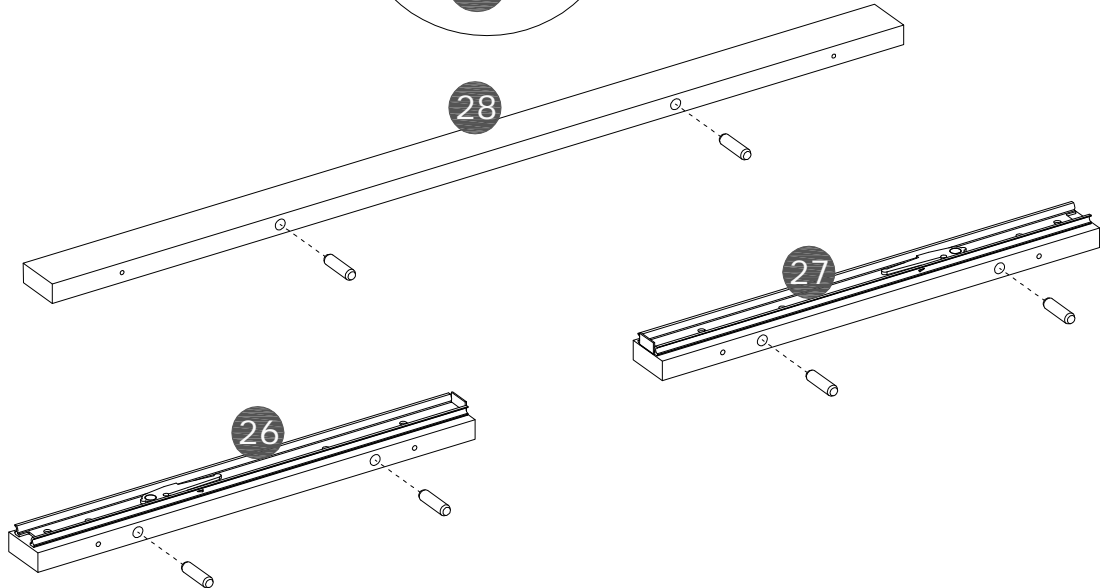
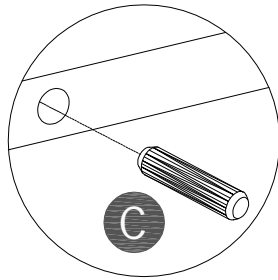

STEP 33

L x6pcs



Raw Side

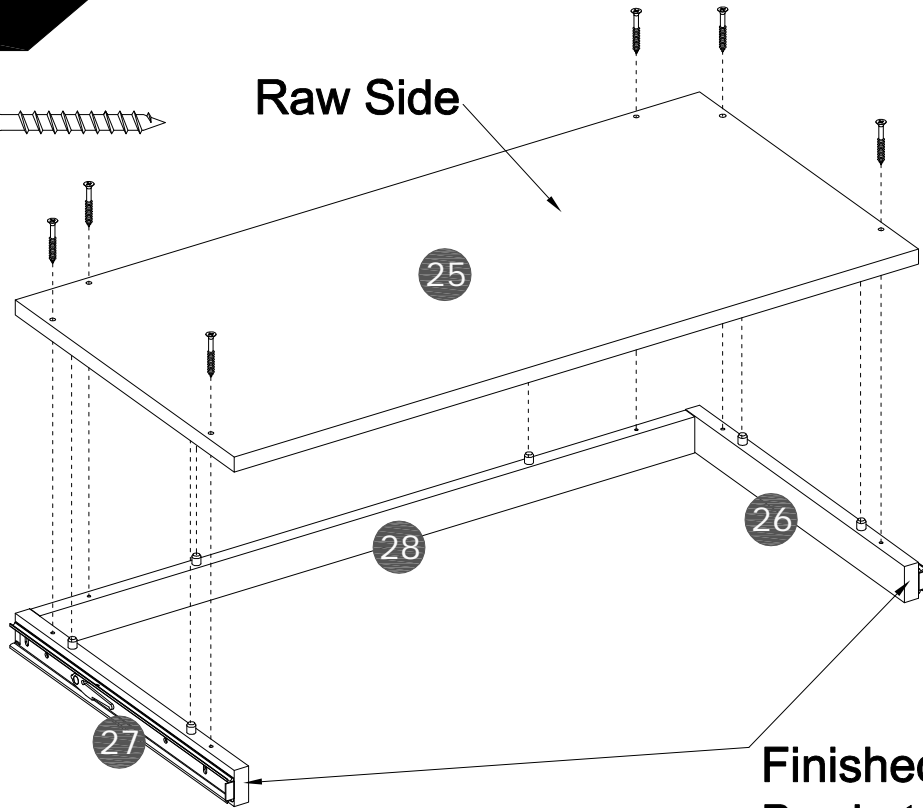

Finished edge
Borde terminado
Cote fini

STEP 34

AA x2pcs



Z x4pcs

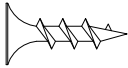

F x1pcs



G x2pcs



7/8" Screw

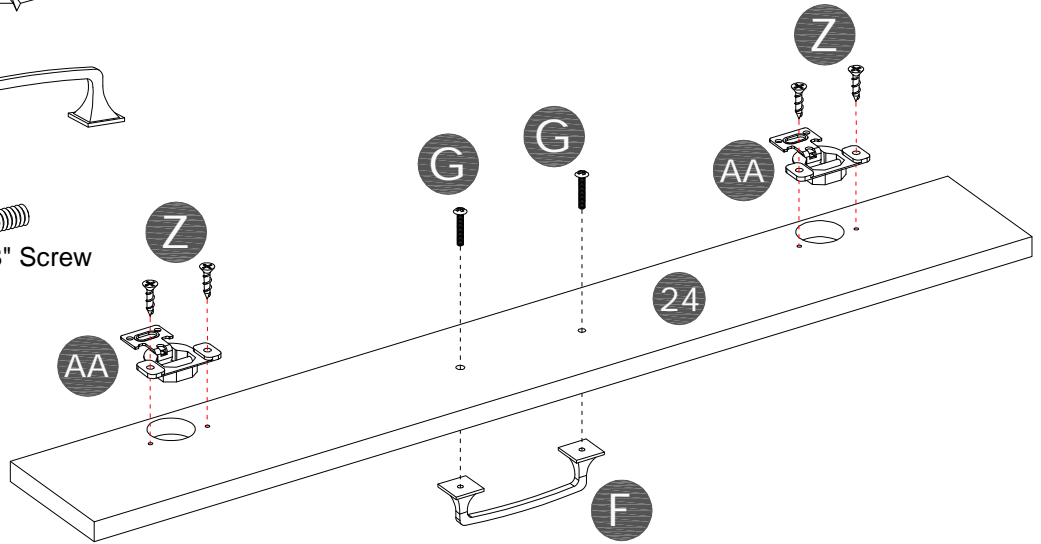

STEP 35

BB x2pcs



X x2pcs

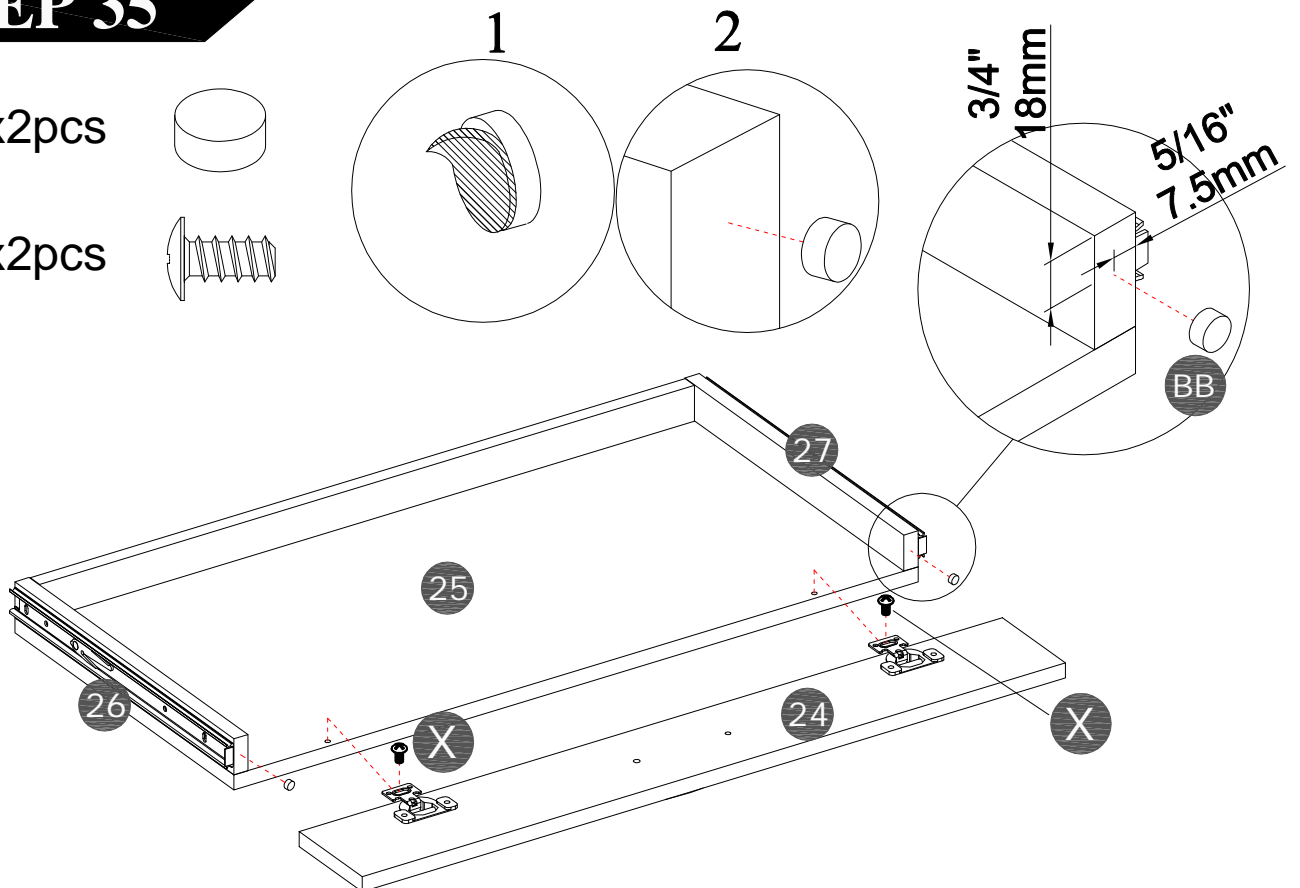
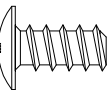

STEP 36

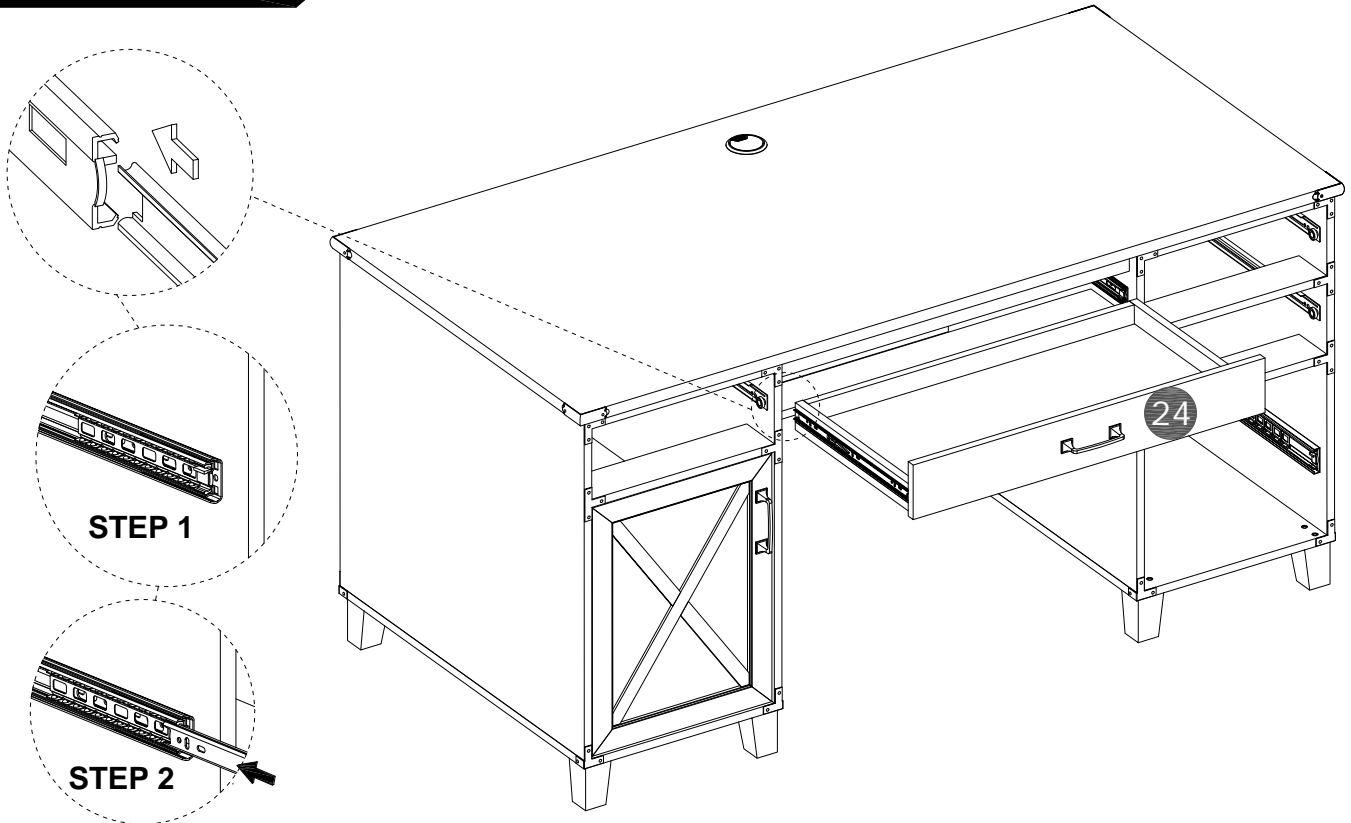

STEP 37

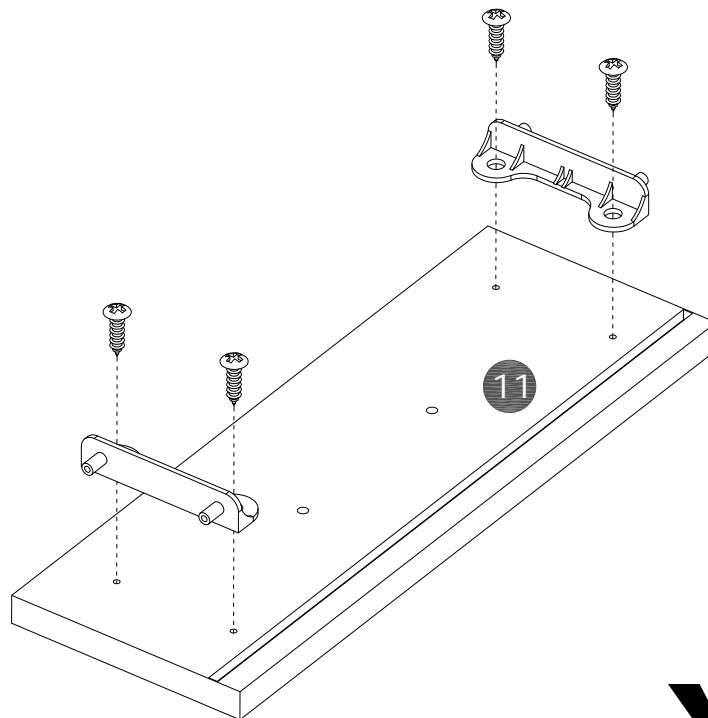
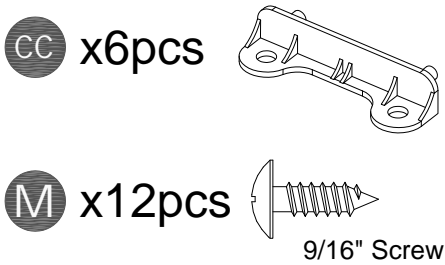

Do not use power screw driver,
use manual screw driver.

X3

STEP 38

Do not use power screw driver,
use manual screw driver.

N x12pcs

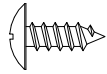

1/2" Screw

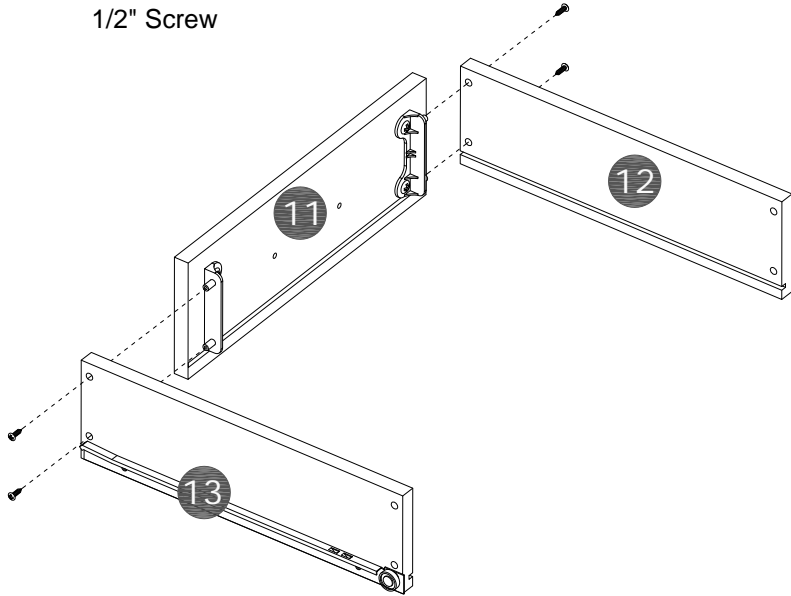

X3

STEP 39

Finished Side

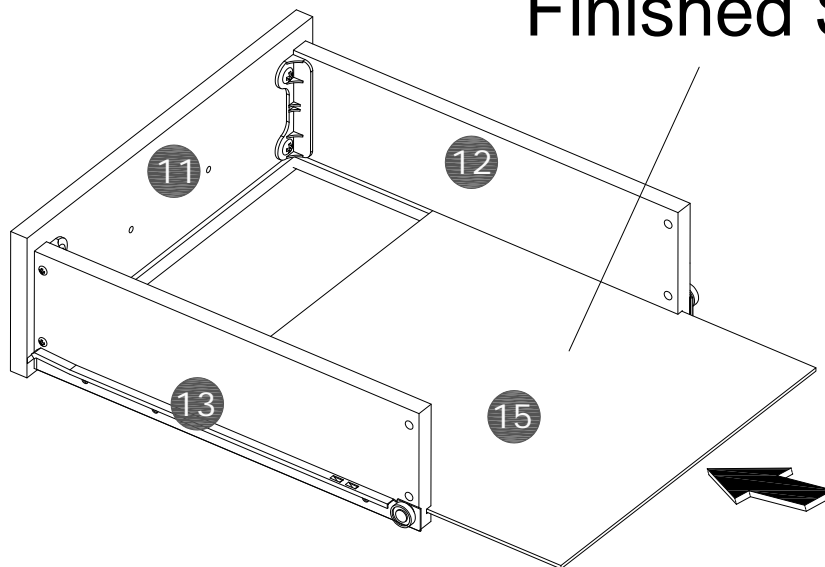

X3

STEP 40

L x12pcs 

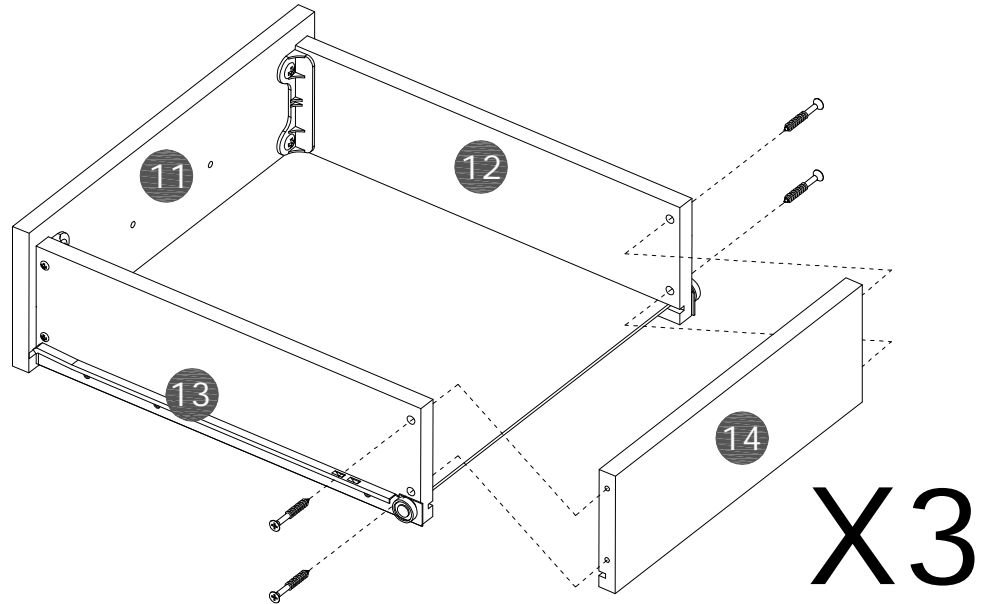

STEP 41

F x3pcs 

G x6pcs  7/8" Screw

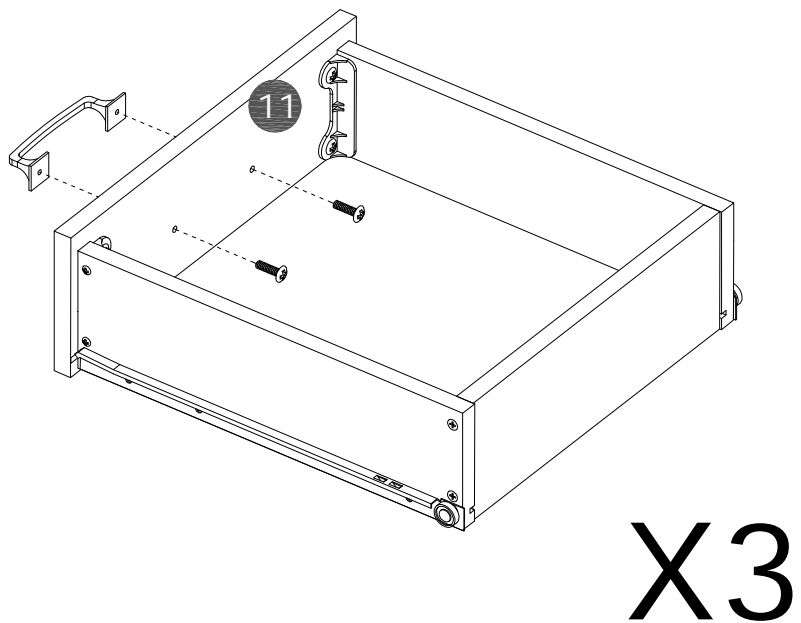

STEP 42

DD x2pcs

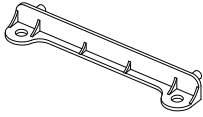

M x4pcs

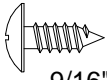

9/16" Screw

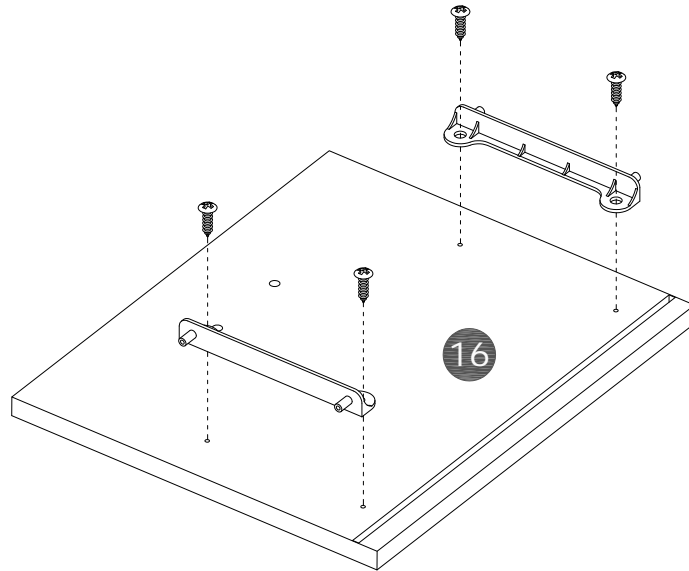

Do not use power screw driver,
use manual screw driver.

STEP 43

N x4pcs

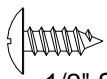

1/2" Screw

Do not use power screw driver,
use manual screw driver.

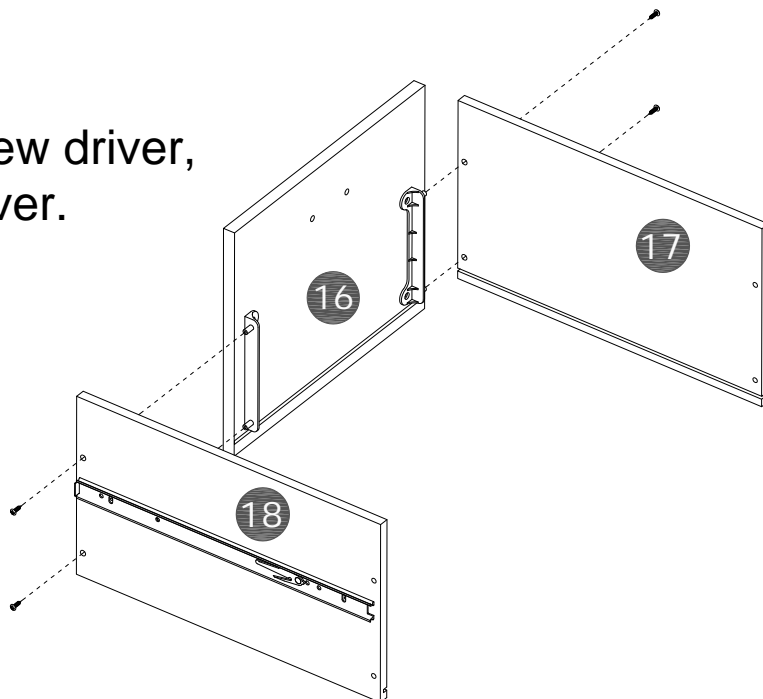

STEP 44

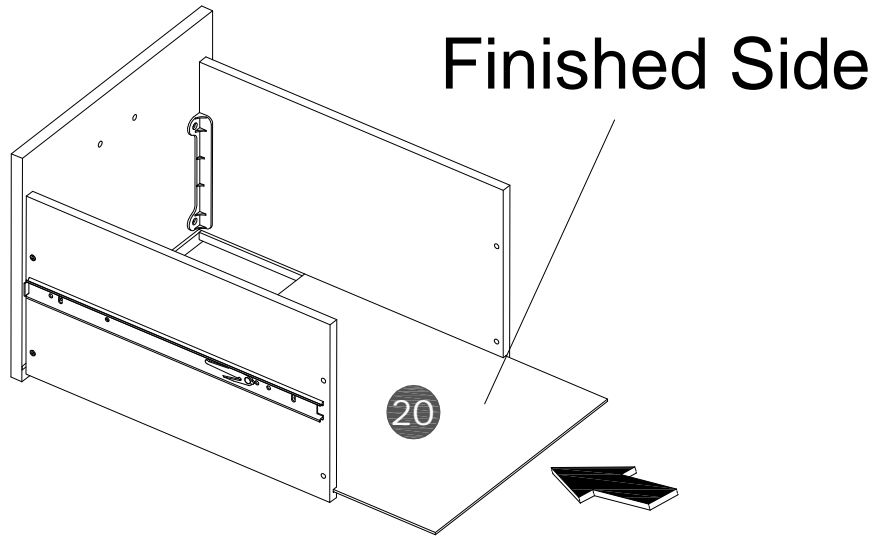

STEP 45

L x4pcs 

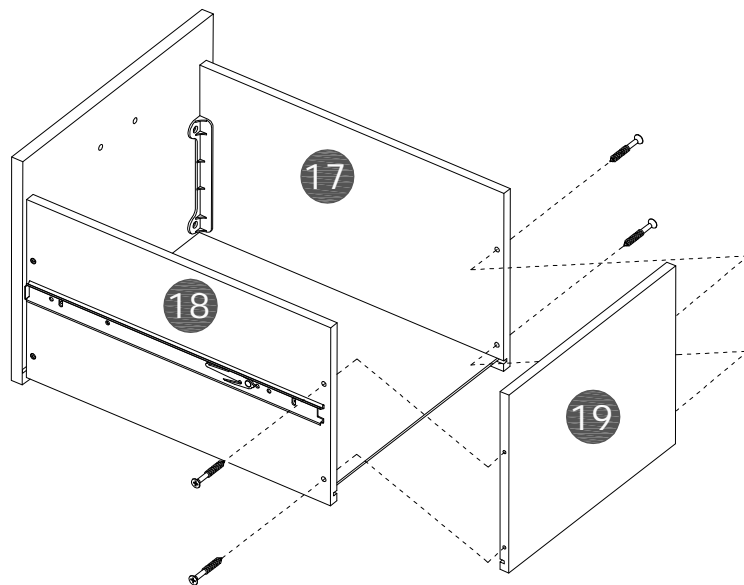

STEP 46

F x1pc



G x2pc



7/8" Screw

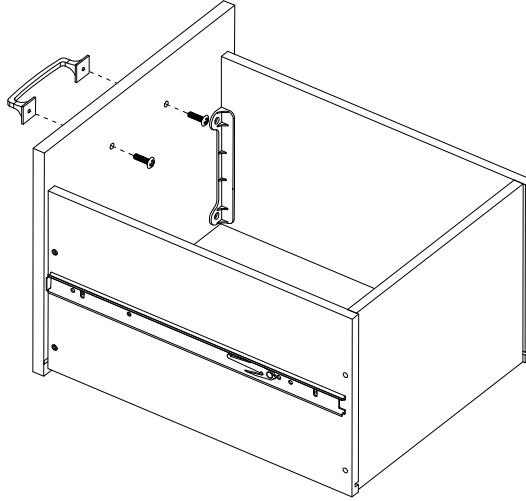

STEP 47

EE x2pc

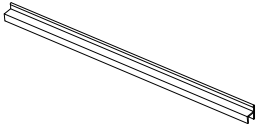

FF x1pc

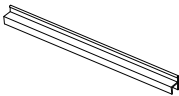

GG x1pc

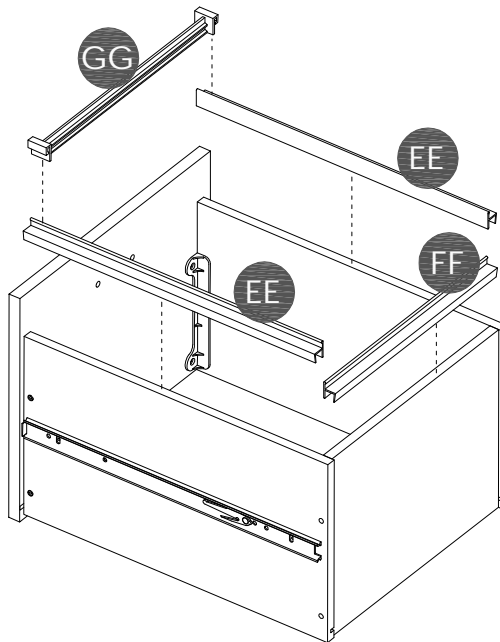
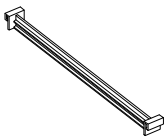

STEP 48

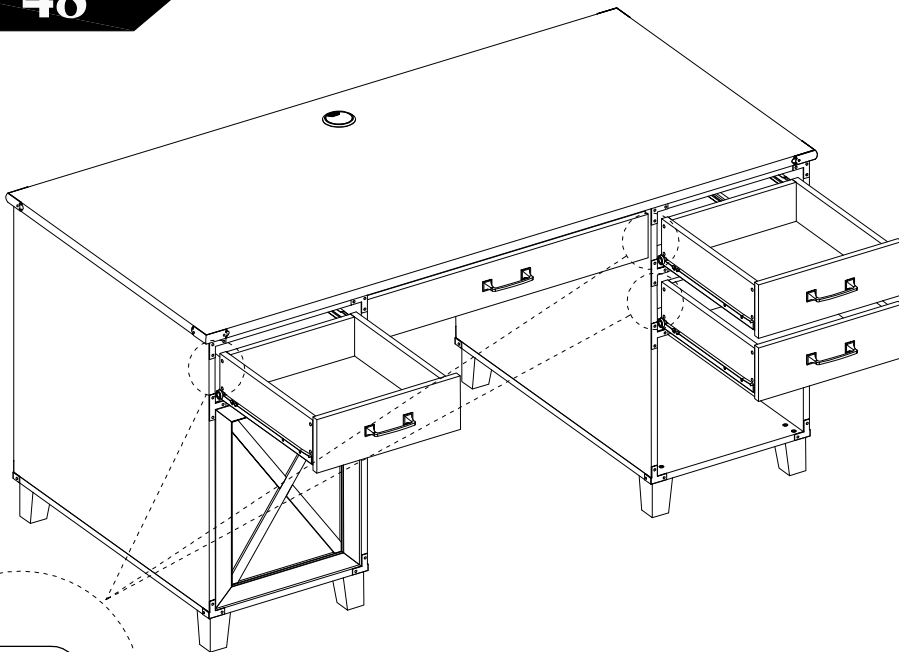

- Move unit to final location.
- Adjust drawer fronts as shown below.

Step1--Loosen screws on back of drawer front brackets as shown.

Step2--Position drawer front as required.

Step3--Tighten screws while holding drawer front in position.

STEP 1.

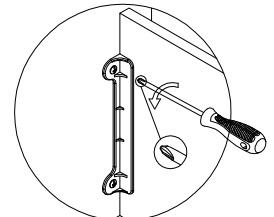

STEP 2.

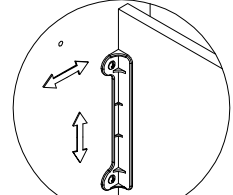

STEP 3.

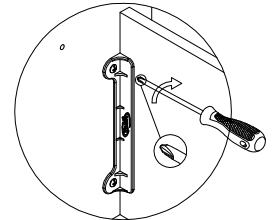

STEP 49

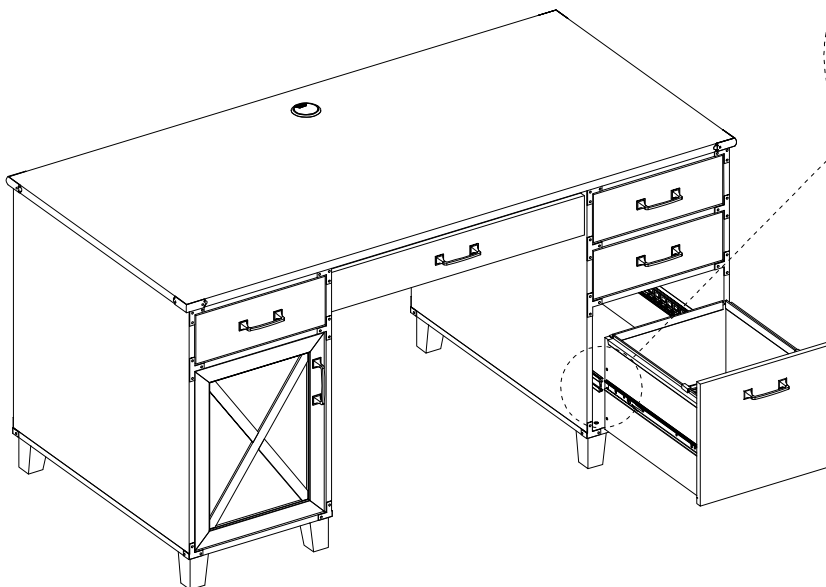

- Move unit to final location.
- Adjust drawer fronts as shown below.

Step1--Loosen screws on back of drawer front brackets as shown.

Step2--Position drawer front as required.

Step3--Tighten screws while holding drawer front in position.

STEP 1.

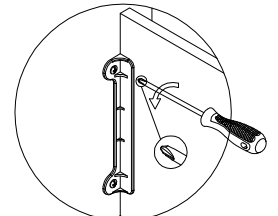

STEP 2.

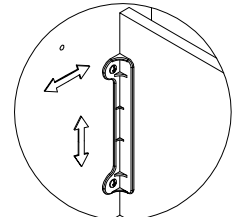

STEP 3.

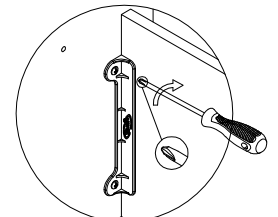

STEP 1

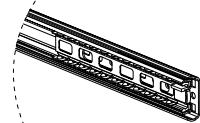

STEP 2

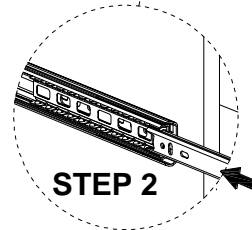

Maximum weight capacities

MAXIMUM WEIGHT: 200 LBS (91KG)

MAXIMUM WEIGHT: 17 LBS (7.7KG)

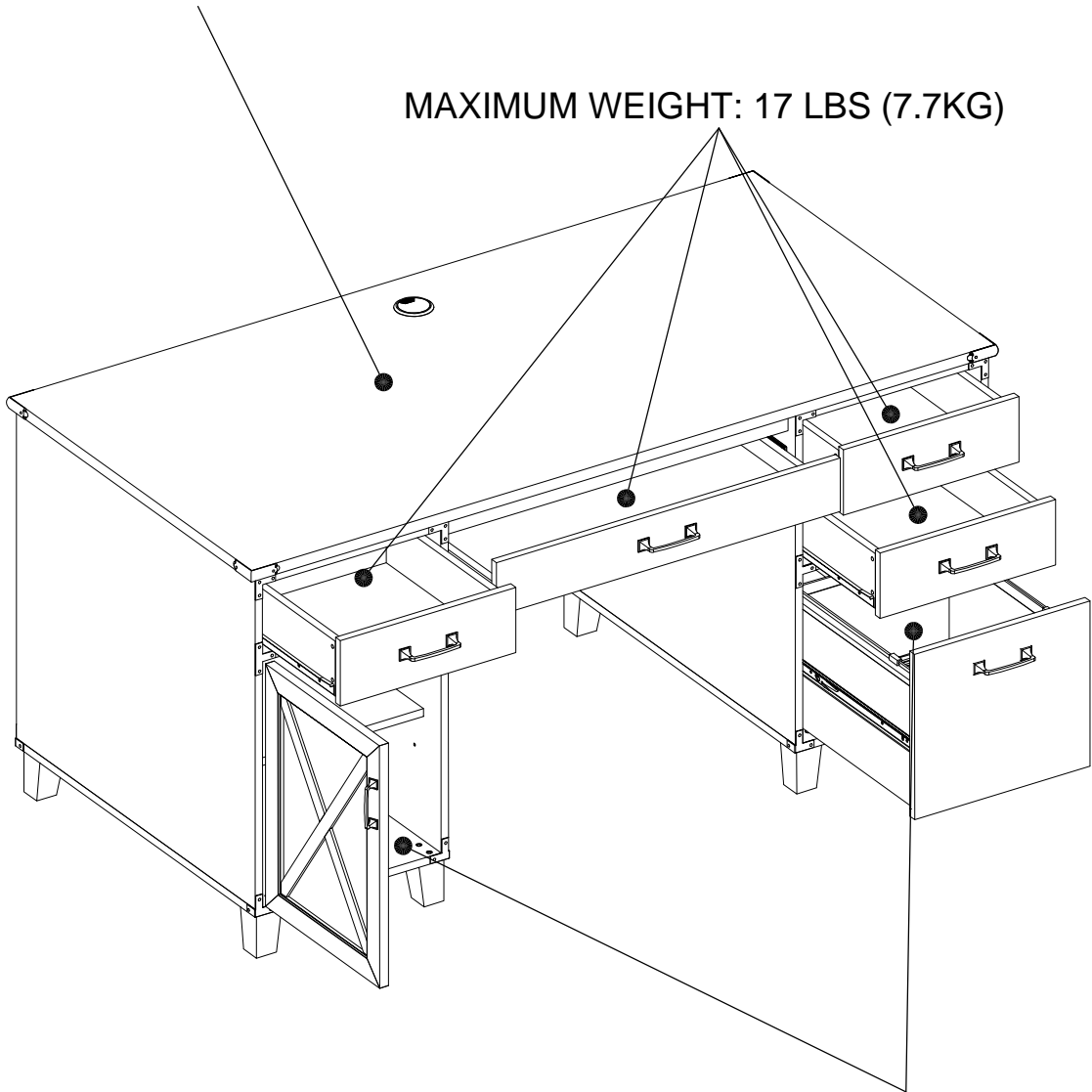

MAXIMUM WEIGHT: 33 LBS (15KG)

THIS PAGE INTENTIONALLY LEFT BLANK

What is Proposition 65?

Proposition 65 is a California law that requires warning labels on products that may contain one of more than 800-plus chemicals or ingredients that the California Office of Environmental Health Hazard Assessment (OEHHA) has deemed to cause cancer or other reproductive toxicity. Chemicals and elements on this list include wood dust, brass, and other everyday substances, which can be found in very common household items, such as: lamps, tableware, jewelry, crystal glasses, electric cords, beauty products, automobiles, and furniture.

Why Did I Find a Proposition 65 Warning on My Home Goods Product?

We include Proposition 65 warnings on all of our products because there is always a chance that one of the 800-plus common chemicals and ingredients listed under this law could potentially be on our furniture or packing materials. We risk large fines under this law, if we don't include this warning.

Should I worry?

We realize you may be worried finding this warning on our products, but we want to reassure you that the hazardous exposure limits for any of these chemicals have never been found on furniture products that we've shipped to our customers. Additionally, this warning label is very common and can be found on almost every piece of furniture sold in the state of California.

Just How Common Are Proposition 65 Warnings?

Proposition 65 warnings have become so common in California that it is hard to take a trip to local bank, grocery store, or restaurant without finding at least one warning. In fact, even the Disney Land Resort has a Proposition 65 warning:

