

# ASSEMBLY INSTRUCTIONS

## 8]bb]b[ 'HUV`Y

ASSEMBLY  
REQUIREMENTS

30 Minutes  
Assembly Time  
(Approximate)

2-Person  
Assembly

### Thank you for purchasing our product!

Please refer and use this assembly instruction to assemble the product.

Contact our customer service department in case there are any missing or damage parts or hardware. Replacement parts are normally shipped within 2 or 3 days.

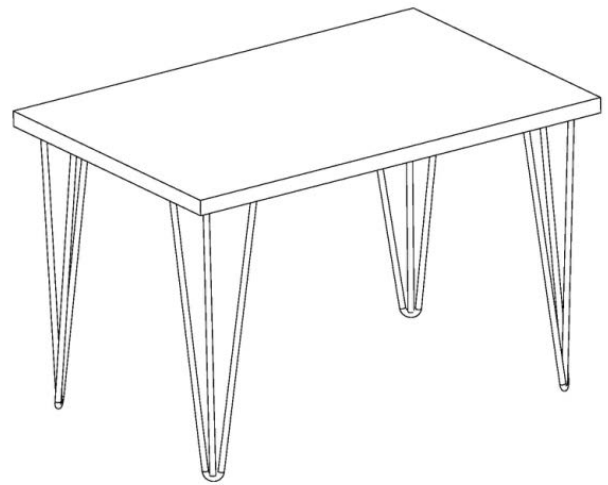

### ASSEMBLY PREPARATION

1. Remove all packaging materials, staples and packing straps from the carton.
2. Refer to Parts List and Hardware List, and ensure parts and hardware are complete before assembly. Contact customer service for missing parts.
3. Place all wooden parts on a clean, flat and soft surface (e.g. carpet or rug) to prevent parts from getting scratched.

### SAFETY PRECAUTION

1. KEEP ALL HARDWARE PARTS OUT OF REACH OF CHILDREN.
2. DISPOSE PLASTIC PACKAGING MATERIAL IMMEDIATELY TO AVOID ANY RISK OF SUFFOCATION TO CHILDREN AND ANIMALS.

### TIPS FOR ASSEMBLY

1. Allow ample room for assembly and assemble the product near where the product will be placed.
2. Assemble the product on a surface that does not scratch or damage the exterior gloss and finish of the furniture.
3. Identify all of the parts, hardware and quantities required for each step.
4. During assembly, do not over-tighten any fittings as this may cause damage.
5. DO NOT USE POWER TOOLS TO ASSEMBLE THIS PRODUCT.
6. Always place the product on a flat, level surface.
7. Do not sit or stand on the partially assembled product; only use the product for which it is intended.





### CARE AND MAINTENANCE

- Use a slightly damp cloth to clean the product. Do not use bleach or abrasive cleaning material.
- Check all the fittings periodically and re-tighten as necessary. Do not use the product if any of the parts is damaged or broken.
- Never allow any kind of liquid to remain on your furniture. Absorption can cause wood to warp or delaminate.
- Do not place hot items (e.g. hot drinks) directly onto the wood surface.
- Do not drag and/or pull the furniture.

This product is for indoor and household use only - not for commercial use.

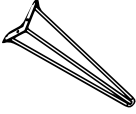
# ASSEMBLY INSTRUCTIONS DINING TABLE

## Parts and Hardware List

Item <b>1</b>	Description Table-top		Quantity 1 PC	Item <b>2</b>	Description Leg		Quantity 4 PCS
<b>A</b>	Screw	 6*20mm	24 PCS	<b>B</b>	Flat Washer	 6*16mm	24 PCS
<b>C</b>	Allen Key		1 PC				

## Assembly Overview

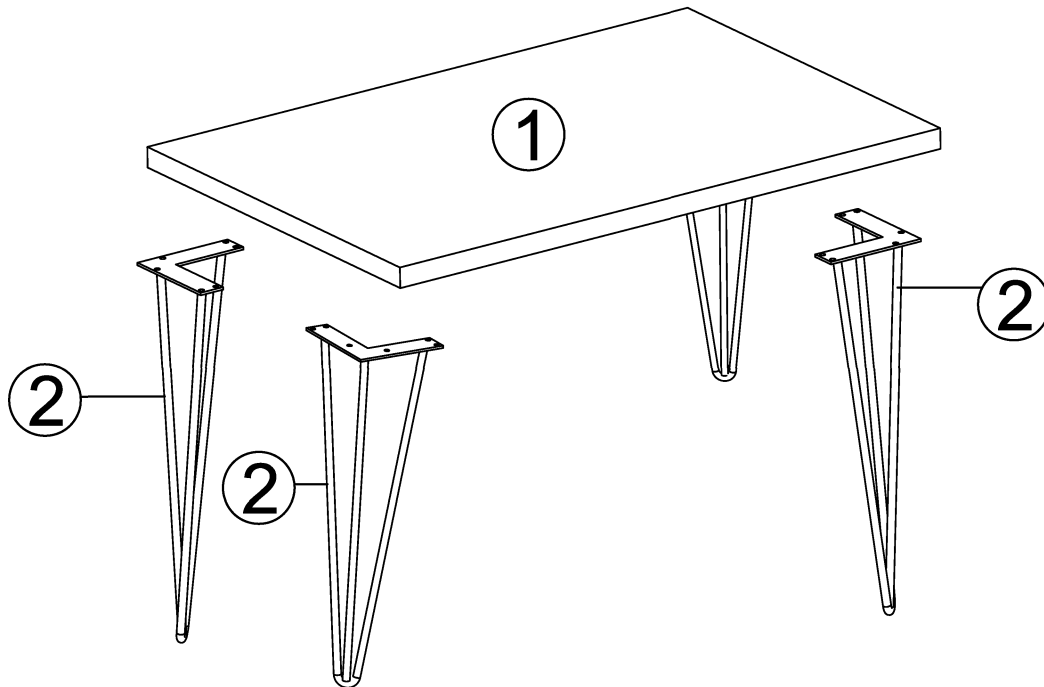

# STEP 1



DO NOT USE POWER TOOLS

A		24 pcs
B		24 pcs
C		1 pc

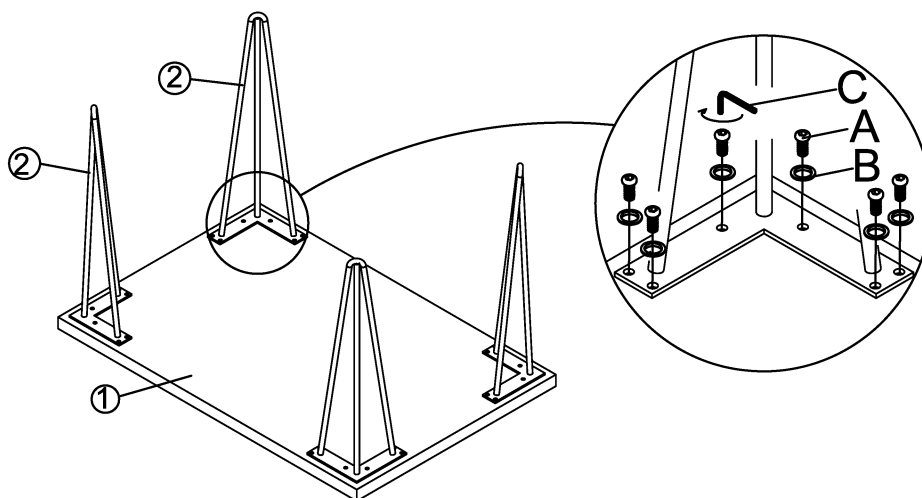

- With assistance, lay Table Top (1) flat with the bottom-side facing up on a material that does not scratch or damage the part.
- Position Leg (2) to align screw hole on (2) to screw holes on (1) at each corner.
- Use Screw (A) fitted with Flat Washer (B) to fasten (2) to (1). Use Allen Key (C) to drive (A). Do not tighten (A) completely until all 6 screws are in place on each leg.
- With assistance, set the table right-side up.

# STEP 2



DO NOT USE POWER TOOLS

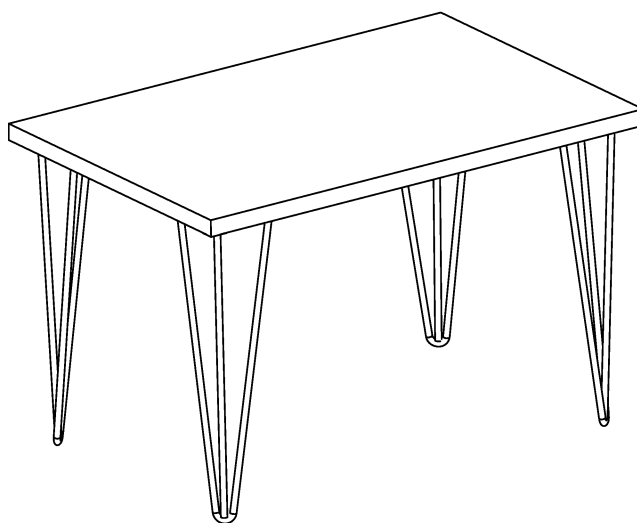

The assembly of the table is complete.