

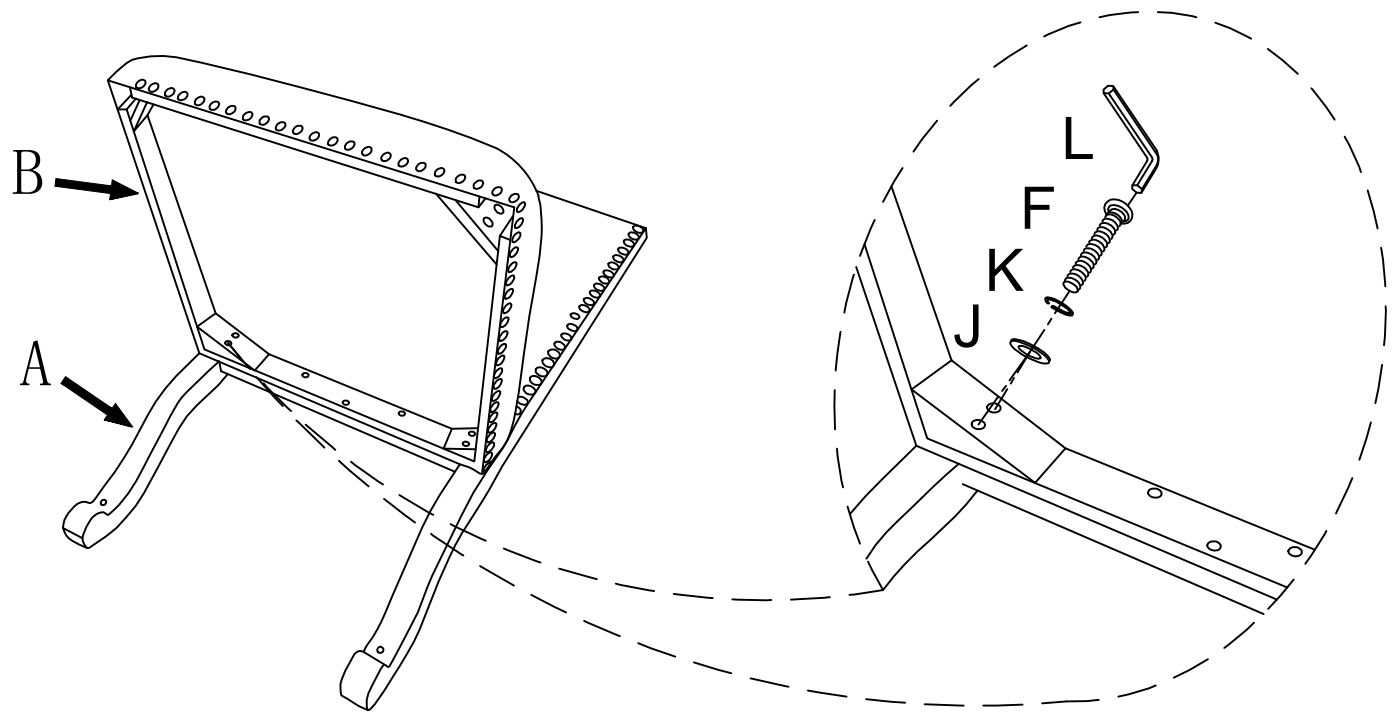

ASSEMBLY INSTRUCTIONS

ITEM# FZR3719

PARTS LIST				HARDWARE LIST			
NO.	DESCRIPTION		Q' ty	NO.	DESCRIPTION		Q' ty
A	Chair Back		1	F	Screw		4
B	Seat Frame		1	G	Screw		4
C	Right Leg		1	H	Screw		3
D	Left Leg		1	I	Screw		8
E	Stretchers		1	J	Flat Washer		11
				K	Lock Washer		11
				L	Allen Wrench		1
				M	Allen Wrench		1
				N	Connecting Metal		4

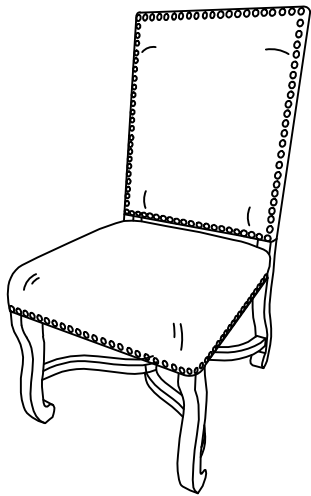

STEP1 :DON'T TIGHTEN THE SCREW AT THIS STEP.

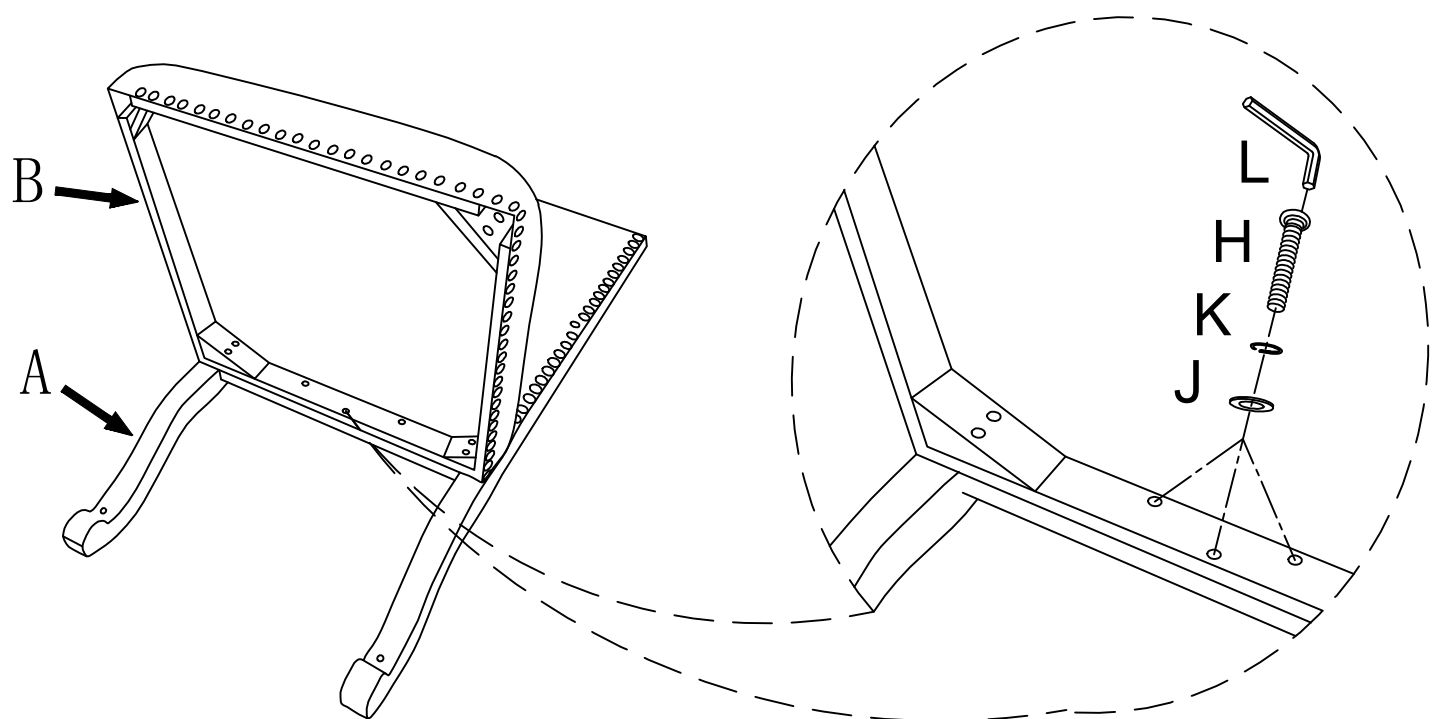

STEP2



ASSEMBLY INSTRUCTIONS

ITEM# FZR3719

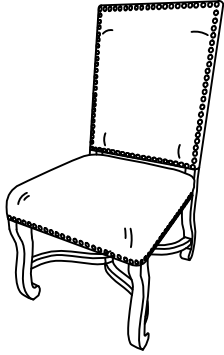

PARTS LIST

NO.	DESCRIPTION		Q' ty
A	Chair Back		1
B	Seat Frame		1
C	Right Leg		1
D	Left Leg		1
E	Stretchers		1

HARDWARE LIST

NO.	DESCRIPTION			Q' ty
F	Screw	$\Phi 5/16'' * 3''L$		4
G	Screw	$\Phi 5/16'' * 2''L$		4
H	Screw	$\Phi 5/16'' * 1-3/4''L$		3
I	Screw	$\Phi 1/4'' * 3/4''L$		8
J	Flat Washer	$\Phi 5/16'' * 19mm$		11
K	Lock Washer	$\Phi 5/16''$		11
L	Allen Wrench	5mm		1
M	Allen Wrench	4mm		1
N	Connecting Metal	31*21*2mm		4

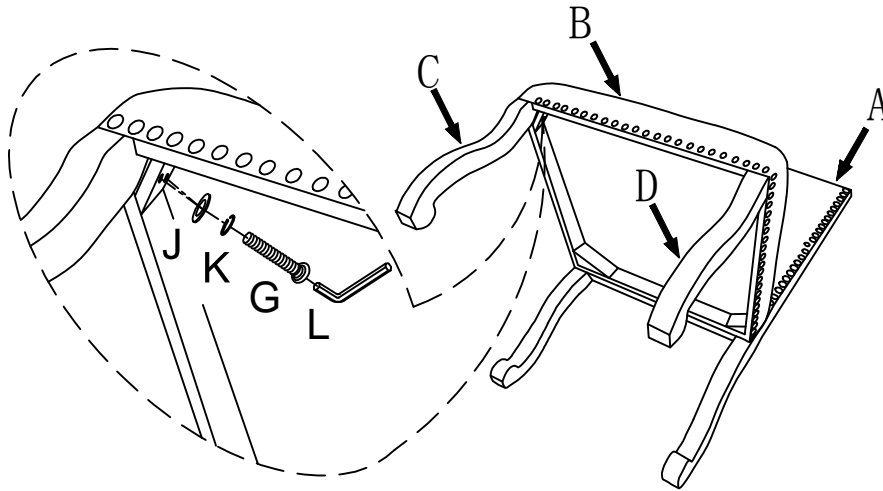

STEP3: DON'T TIGHTEN THE SCREW AT THIS STEP.

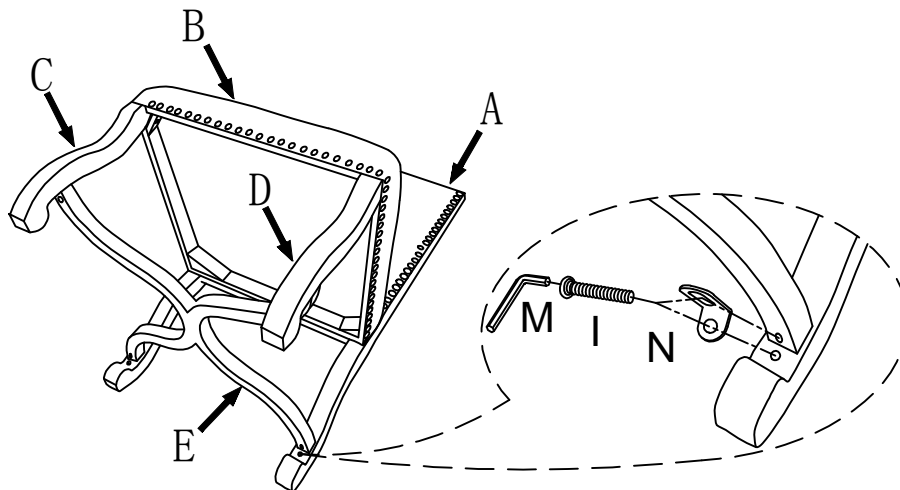

STEP4: TIGHTEN ALL SCREWS.