

Assembly Instructions

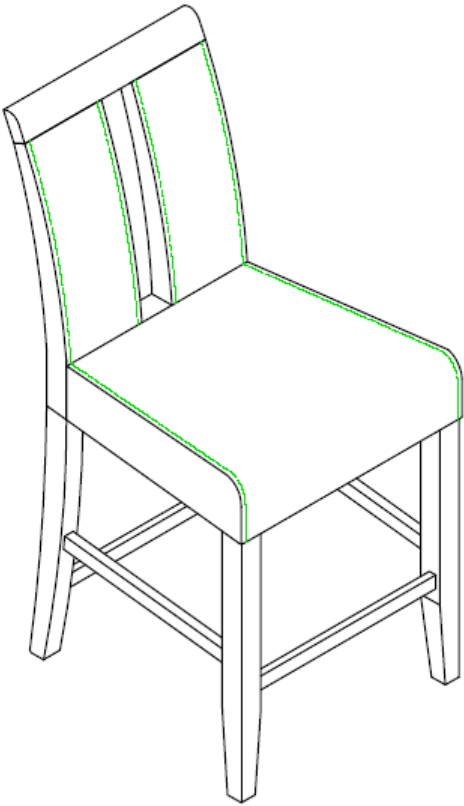

ASSEMBLY RATING

The Assembly Rating is a 5-point system that shows the degree of effort needed in assembling a specific product (with 1 being easy and 5 being difficult). For some products, two persons are recommended.

Tools Required for Assembly:

Allen Wrench



(Included)

Phillips Screwdriver



(Not Included)

EASY



DIFFICULT

Thank you for your purchase!

We hope you will enjoy your new product for many years to come. Our commitment to providing quality products does not simply end when a purchase is made. We stand behind our products and will provide any support needed in order for you to fully enjoy your purchase. Your satisfaction is the greatest recognition we could have.

Because we value your trust in our company, we will do our best to meet your service expectations. Should you have any assembly related questions, parts replacement requests, comments or suggestions, please feel free to contact us any time. To help expedite the service, please have the assembly instructions available, along with your order receipt.

ASSEMBLY & CARE ADVICE

FOR YOUR FURNITURE TO LAST, CORRECT ASSEMBLY AND PROPER MAINTENANCE ARE NECESSARY. PLEASE FOLLOW THE INFORMATION PROVIDED BELOW TO FULLY ENJOY YOUR FURNITURE.

BASIC ASSEMBLY TECHNIQUES

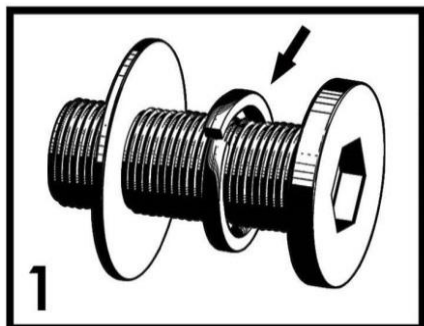

1 When lock or spring washer is used in an assembly, please make sure the lock or spring washer is placed between the larger flat washer and the head of the screw or bolt.

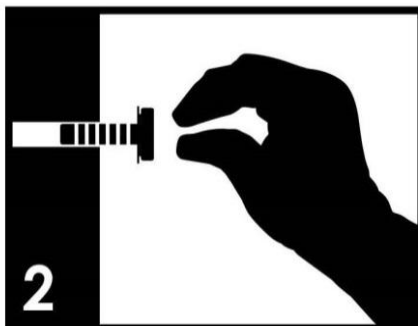

2 Position each part correctly and insert screws or bolts into their respective holes by hand tighten or using the proper hand tool. Only tighten when step is completed or when instructed to do so.

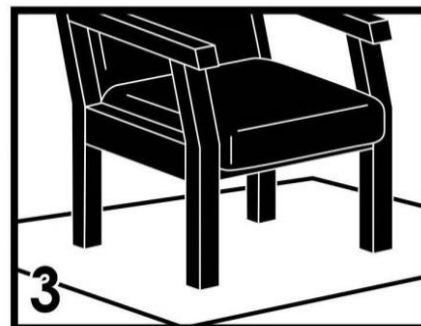

3 Use cardboard or carpet area when assembling furniture to prevent scratches. Make sure the furniture rests on a flat and level surface with each leg evenly touching the floor.

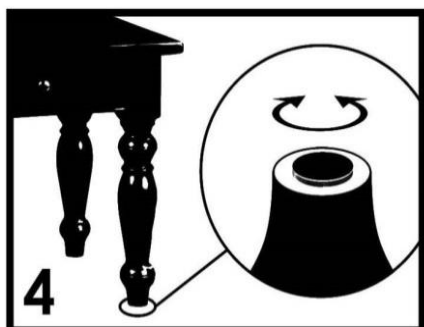

4 Some furniture comes with height adjustment knobs underneath each leg. To lower or to raise each leg, you need to turn clockwise or counterclockwise, respectively.

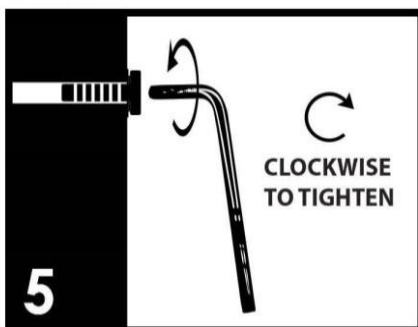

5 Make sure all parts are properly aligned, then use the appropriate hand tool to completely tighten the bolts or screws. Do not use power tools and do not overtighten.

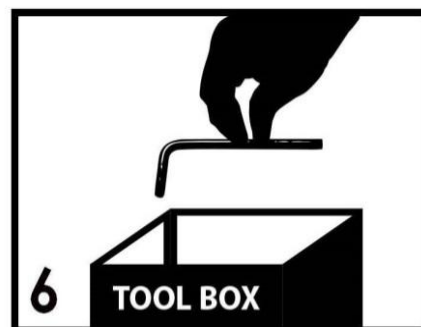

6 Save the instructions and store the Allen wrench or any supplied tool for later maintenance. After two weeks, check and tighten any loose hardware and repeat again every six months thereafter.

IT IS THE USER'S RESPONSIBILITY TO MAINTAIN THE FURNITURE. THE HARDWARE MAY LOOSEN OVER TIME AND MAY CAUSE THE FURNITURE TO BE WOBBLY AND UNABLE TO SUPPORT ITS INTENDED WEIGHT CAPACITY. THIS MAY LEAD TO COLLAPSE AND MAY CAUSE SERIOUS INJURY.



FAILURE TO FOLLOW THE GUIDELINES ABOVE MAY RESULT IN INJURY AND/OR PROPERTY DAMAGE.

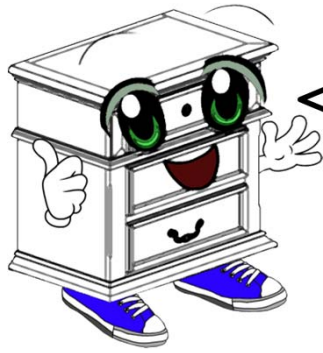





Before you begin, please read Page 3 of "Assembly and Care Advice".



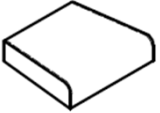
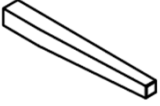
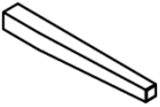

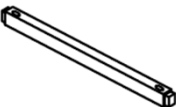



And remember, do not tighten until each step is completed or instructed.

MD

Parts List

-  #1 x 1 pc x 2
Backrest w/Legs
-  #2 x 1 pc x 2
Seat
-  #3 x 1 pc x 2
Right Front Leg
-  #4 x 1 pc x 2
Left Front Leg
-  #5 x 1 pc x 2
Front Leg Support
-  #6 x 1 pc x 2
Right Leg Support
-  #7 x 1 pc x 2
Left Leg Support

Hardware List

-  #A x 2 pcs x 2
Bolt 5/16"x1-3/4"
-  #B x 4 pcs x 2
Bolt 5/16"x2"
-  #C x 4 pcs x 2
Bolt 5/16"x3-1/4"
-  #D x 10 pcs x 2
Flat Washer
-  #E x 10 pcs x 2
Lock Washer
-  #F x 1 pc
Allen Wrench
-  #G x 1 pc x 2
Wood Dowel
-  #H x 6 pcs x 2
Wood Screw

Note: The above parts and hardware are shown for a complete assembly of ONE chair. However, the actual parts and hardware (with an exception of the Allen wrench) in the box will be twice the quantities listed to include the assembly of the second chair.



Insert the front leg support (#5) into the right front leg (#3) and the left front leg (#4).

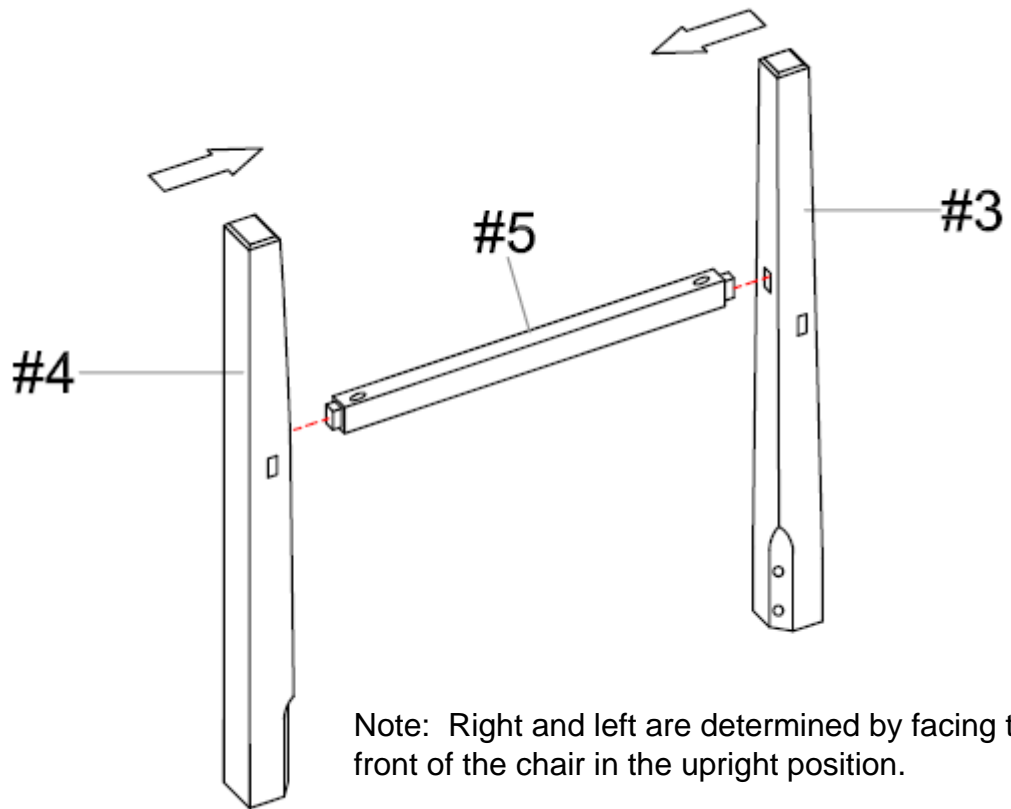

Note: Right and left are determined by facing the front of the chair in the upright position.



#B x 4 pcs
#D x 4 pcs
#E x 4 pcs
#G x 1 pc

- I. Place the seat (#2) facing down on a protected surface. Insert a wood dowel (#G) into the center hole of the seat (#2).
- II. Align the assembled front legs with the pre-drilled holes of the seat (#2).
- III. Prepare 4 bolt assemblies by inserting FIRST the lock washer (#E) onto the bolt (#B) and then the flat washer (#D) onto the SAME bolt (#B), in that order.
- IV. Insert the bolt assembly through the corner holes of the seat (#2) and secure those bolts using the Allen wrench (#F) to lock them with the right front leg (#3) and the left front leg (#4).

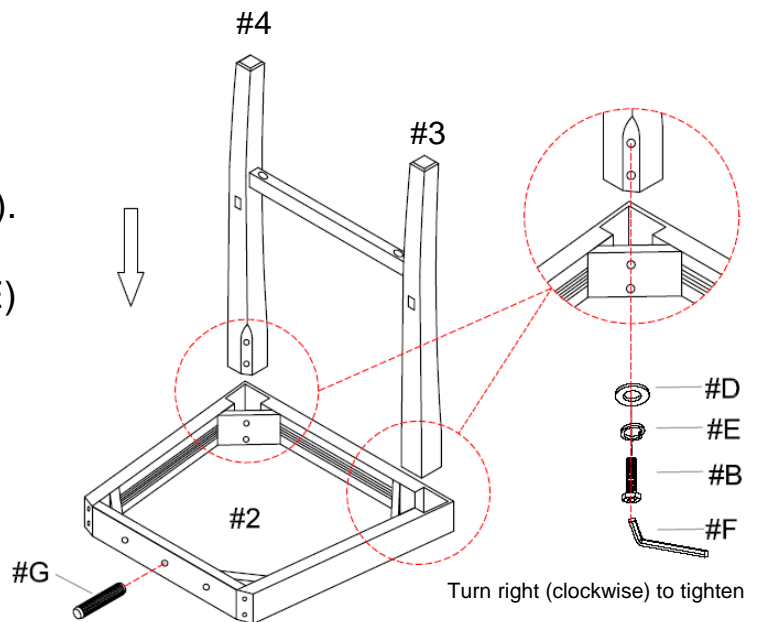



#3

#A x 2 pcs
#D x 2 pcs
#E x 2 pcs

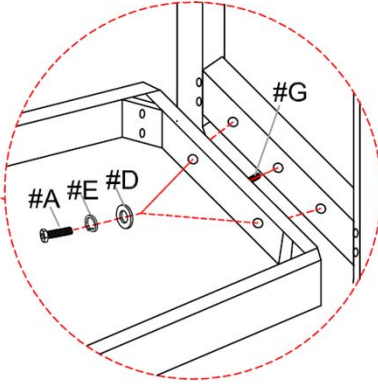
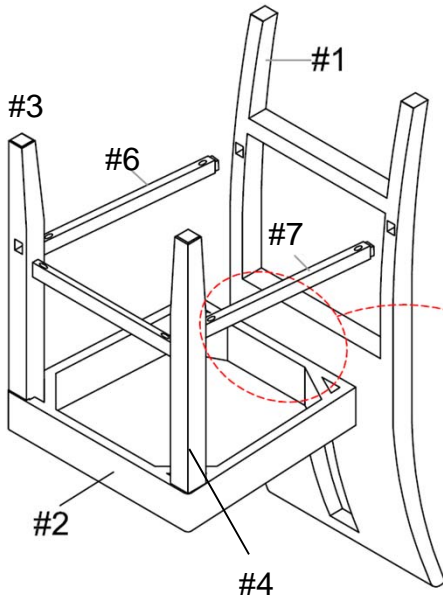

Turn right (clockwise) to tighten

- I. Insert the right leg support (#6) into the right front leg (#3) and insert the left leg support (#7) into the left front leg (#4).
- II. Align the backrest with legs (#1) with the wood dowel (#G) and the other ends of the leg supports.
- III. Prepare 2 bolt assemblies by inserting FIRST the lock washer (#E) onto the bolt (#A) and then the flat washer (#D) onto the SAME bolt (#A), in that order.
- IV. Insert the bolt assemblies through the holes near the wood dowel (#G) of the seat (#2) and secure those bolts using the Allen wrench (#F) to lock them with the backrest with legs (#1).



#4

#C x 4 pcs
#D x 4 pcs
#E x 4 pcs

- I. Prepare 4 bolt assemblies by inserting FIRST the lock washer (#E) onto the bolt (#C) and then the flat washer (#D) onto the SAME bolt (#C), in that order.
- II. Insert the bolt assemblies through the corner holes of the seat (#2) and secure those bolts using the Allen wrench (#F) to lock them with the backrest with legs (#1).

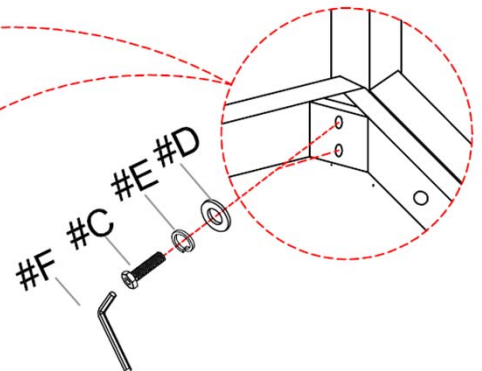
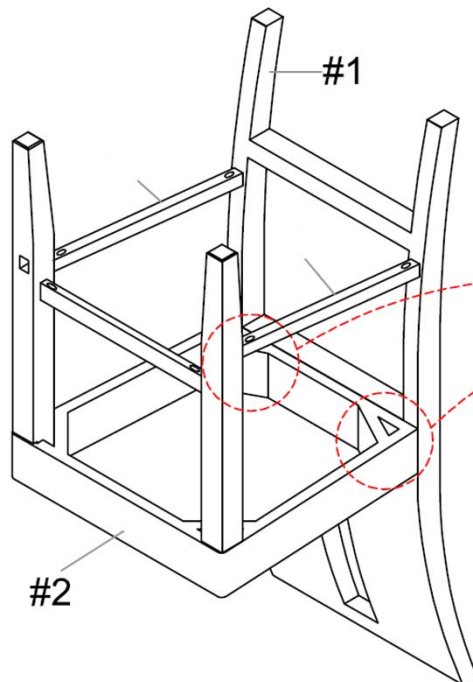

Turn right (clockwise) to tighten



#H x 6 pcs

Turn right (clockwise) to tighten

Secure all the leg supports with 6 wood screws (#H) using a Phillips screwdriver to lock them with the backrest with legs (#1), the right front leg (#3) and the left front leg (#4).

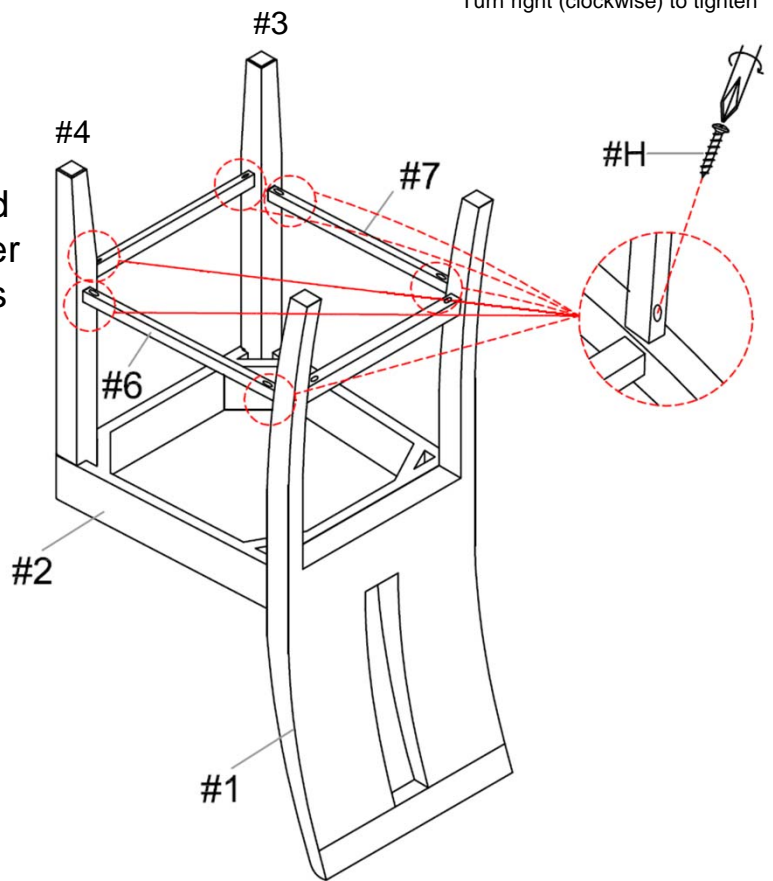

Carefully place the completed chair in the upright position. Make sure the chair is rested on a flat surface and does not feel loose or wobbly. If it does, double check that the bolts/screws are secured and properly tightened.

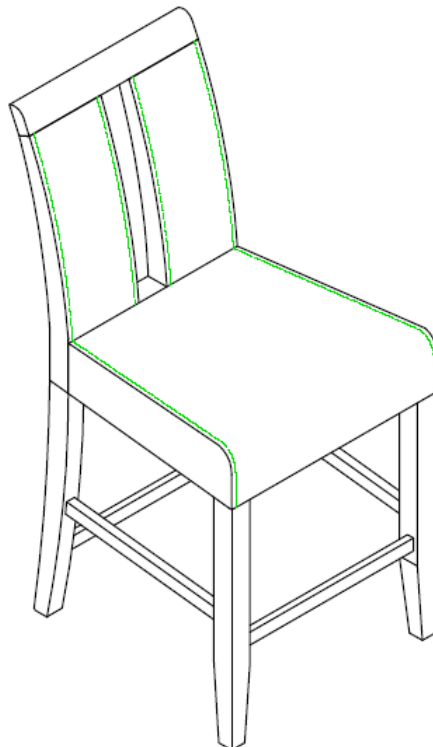

ASSEMBLE EVERYTHING EXACTLY THE SAME FOR THE SECOND CHAIR