

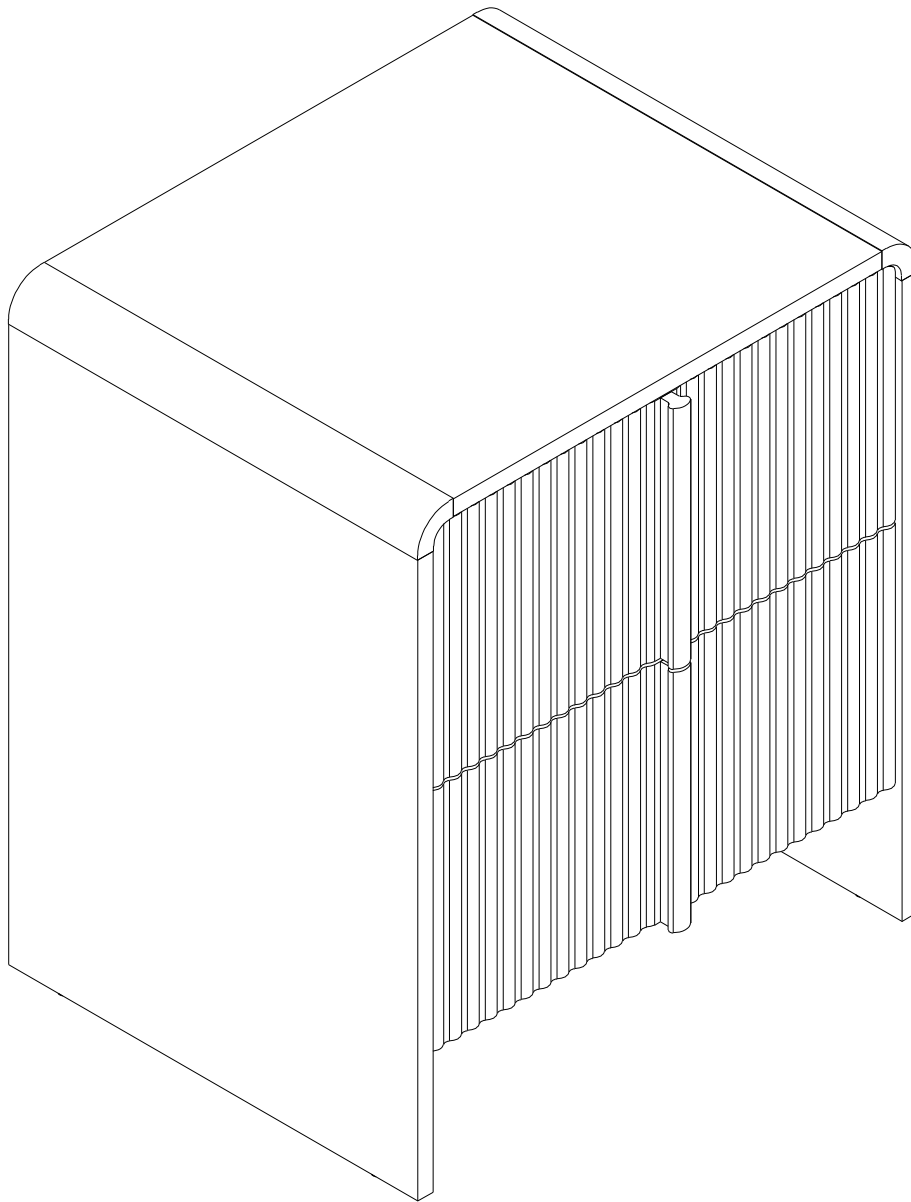

**MANHATTAN
COMFORT**

NS1670

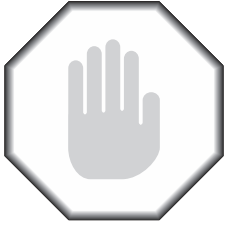



STOP!

Before beginning the assembly process, ensure all boxes and parts have been delivered.

FOR BEST RESULTS:

- Do not throw away packaging materials until assembly is complete.
- Assemble item on a soft surface, such as cardboard or carpet, to protect finish.
- Proper assembly requires two people.

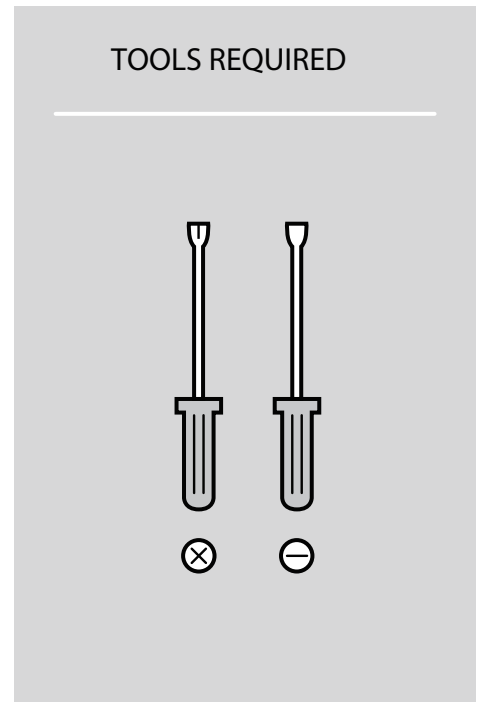
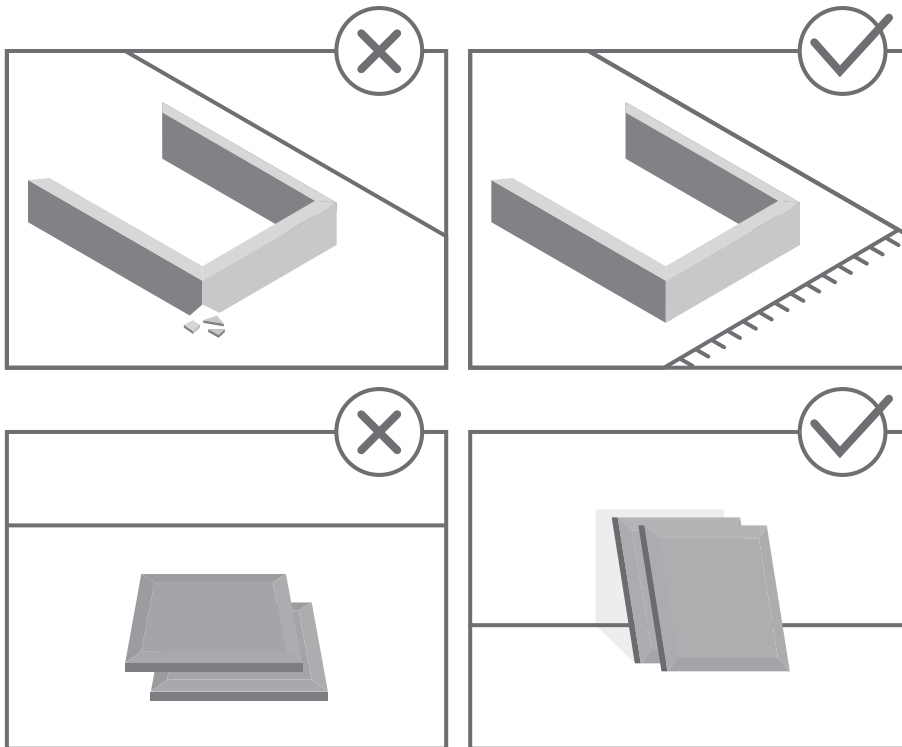

View our assembly video online:
WWW.MANHATTANCOMFORT.COM



Stuck? Question? We are here to help.
tel: 908-888-0818
e-mail: help@manhattancomfort.com

Support Site



Included in this package:

- A. TOP PANEL(1)
- B. BACK LOWER PANEL (1)
- C. LEFT PANEL (1)
- D. RIGHT PANEL (1)
- E. BACK UPPER PANEL (1)
- F. FRONT HORIZONTAL PANEL (2)
- G. CURVED BAR (2)
- H. DRAWER LEFT PANEL (2)
- I. DRAWER RIGHT PANEL (2)
- J. DRAWER BACK PANEL (2)
- K. DRAWER BOTTOM PANEL (2)
- L. DRAWER SUPPORT PANEL (2)
- M. DRAWER UPPER FRONT PANEL (1)
- N. HANDLE (2)
- O. DRAWER LOWER FRONT PANEL (1)

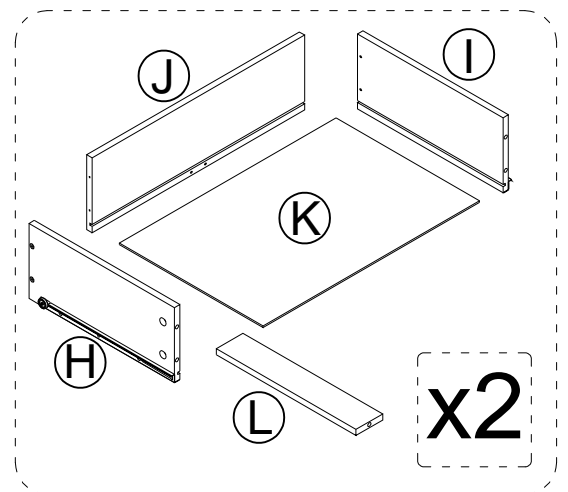
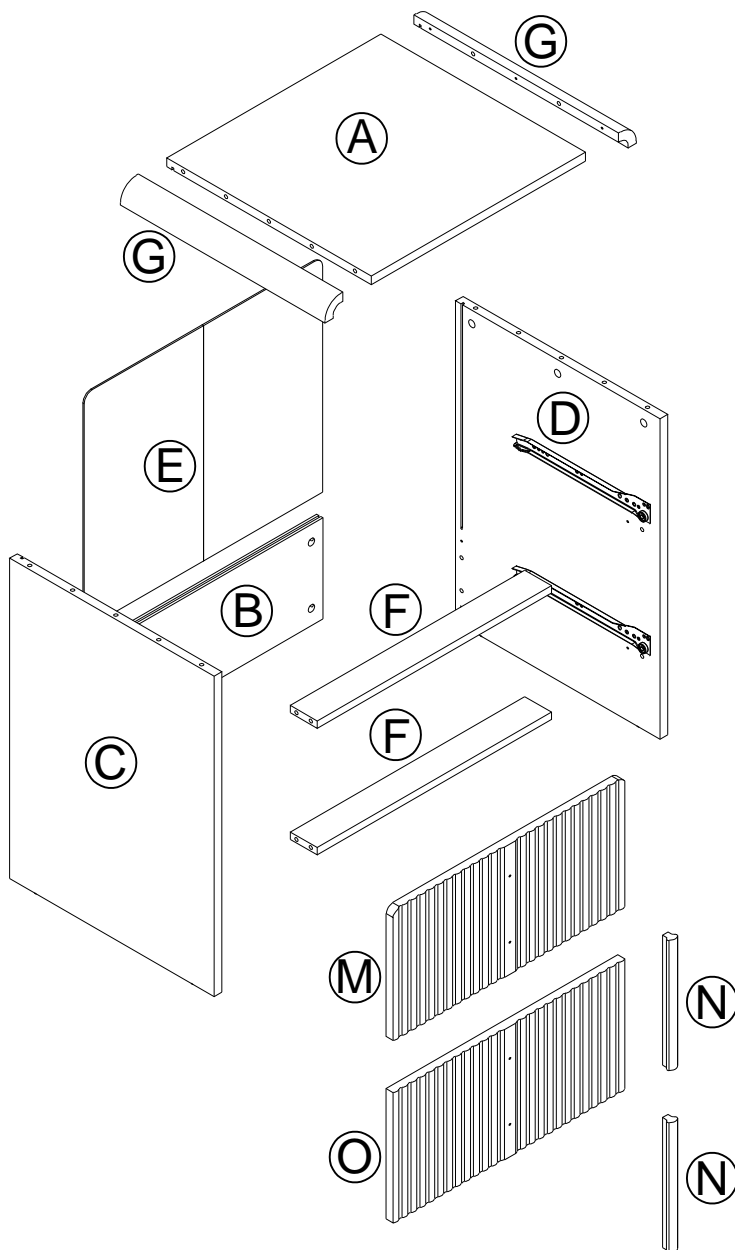

Hardware Identification

① KD BOLT - 30pcs
L=35mm



② KD LARGE CAM - 20pcs
Ø15*11mm

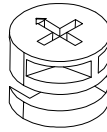

③ COVER CAP - 30pcs

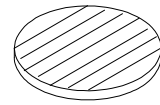

④ WOOD DOWEL-16pcs
Ø8*30mm

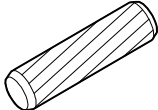

⑤ KD SMALL CAM - 10pcs
Ø15*9mm

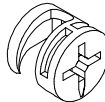

⑥ SCREW - 12pcs
Ø4*38mm

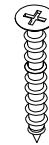

⑦ PLASTIC WEDGE - 10pcs

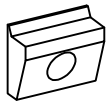

⑧ SCREW - 10pcs
Ø3*17mm

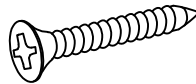

⑨ BOLT - 4pcs

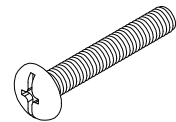

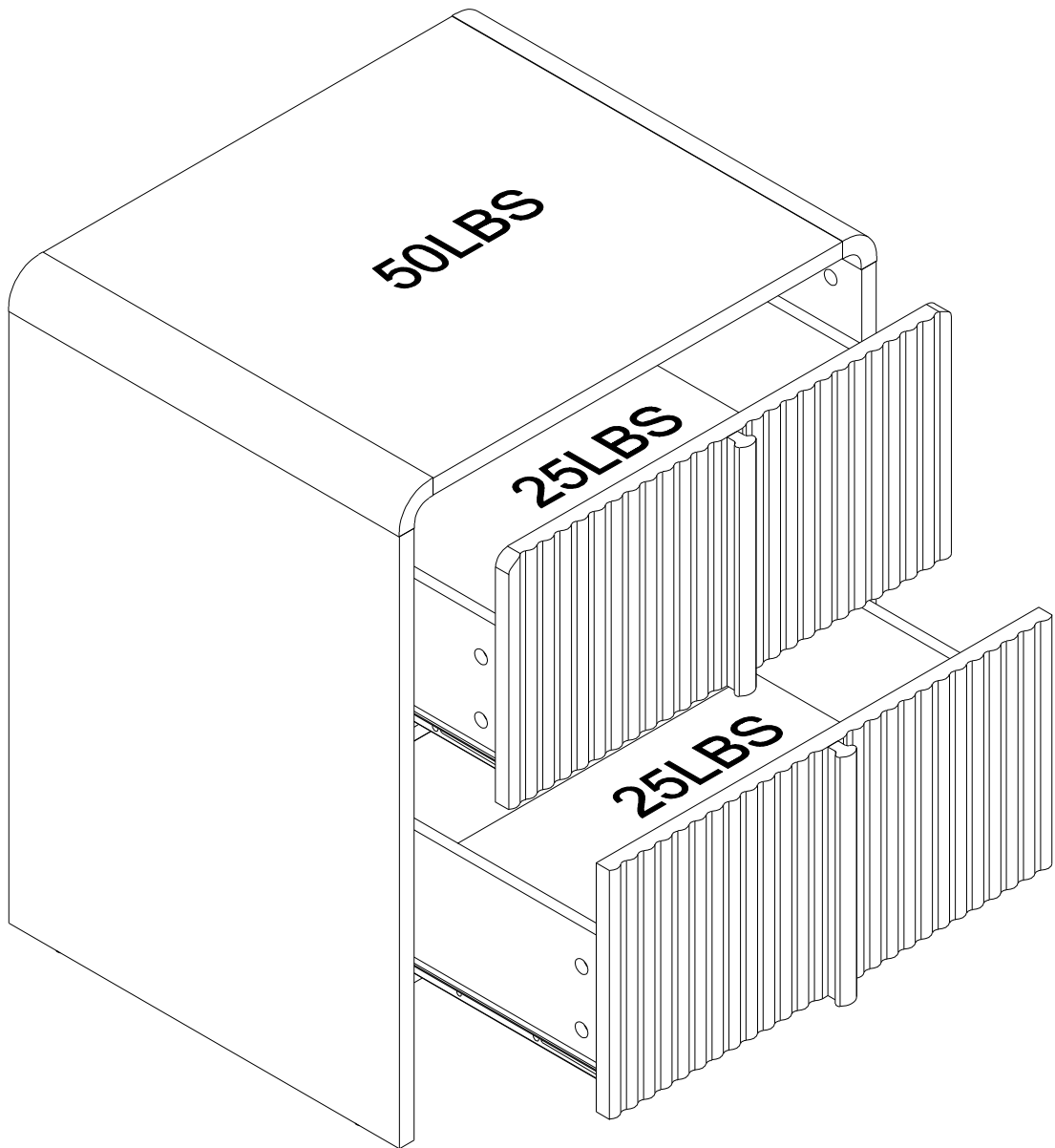

Step 1:

* Insert Twenty KD BOLT (1) to the LEFT PANEL (C), RIGHT PANEL(D) and Two the CURVED BAR (G).

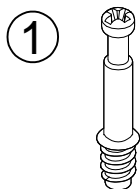

(20 PCS)

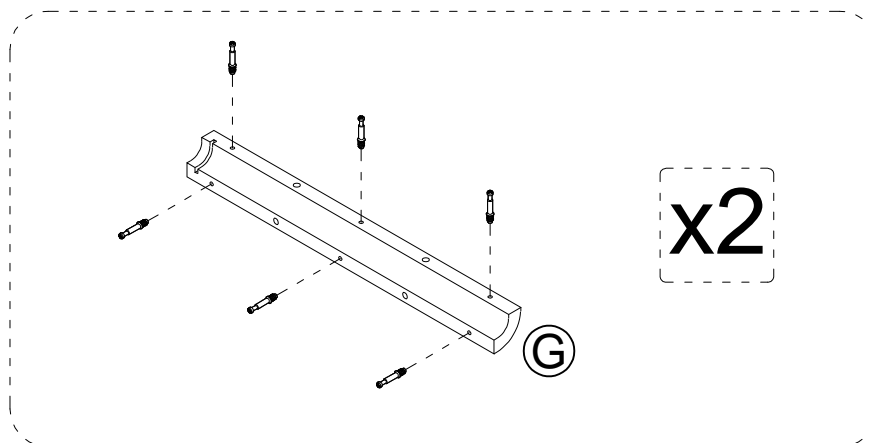
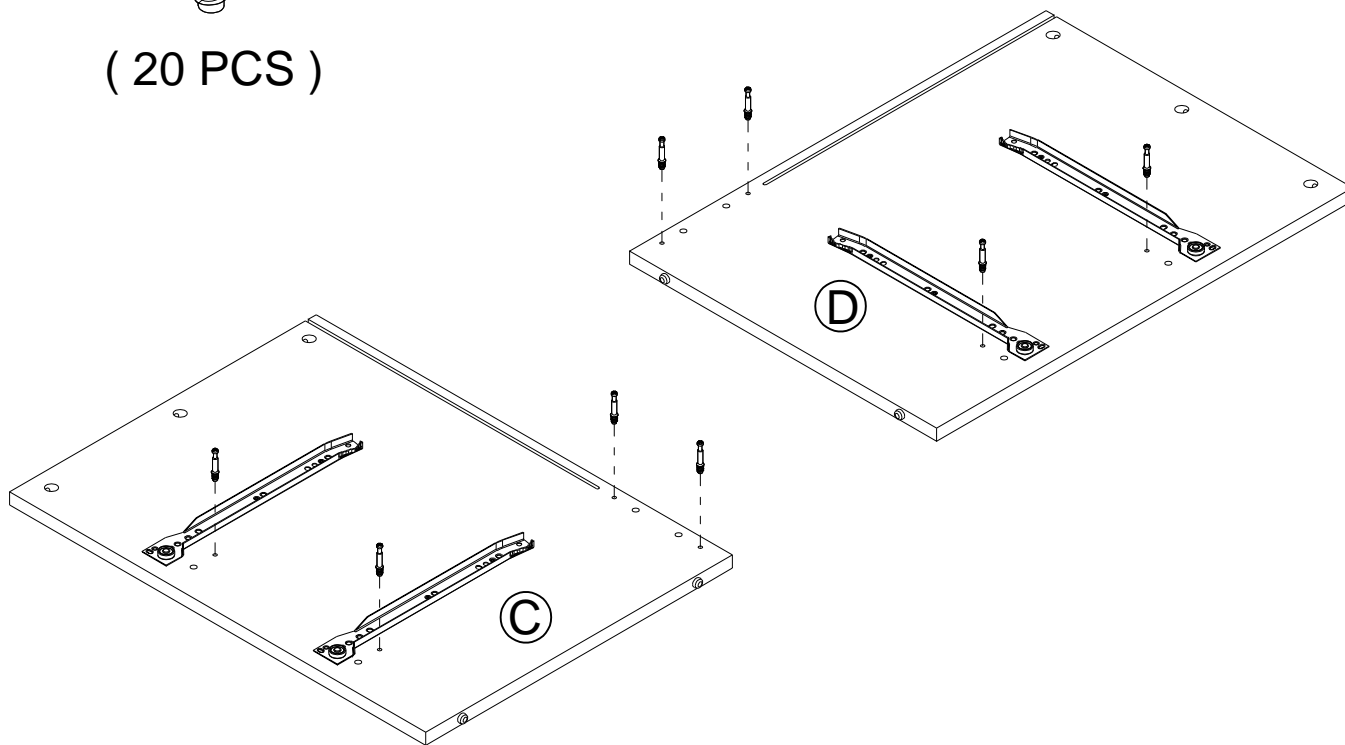

Step 2:

* Attach the Two FRONT HORIZONTAL PANEL (F) and BACK LOWER PANEL(B) to the LEFT PANEL (C) and RIGHT PANEL (D) by the Eight KD LARGE CAM (2) , Eight COVER CAP (3) and Eight WOOD DOWEL (4) .

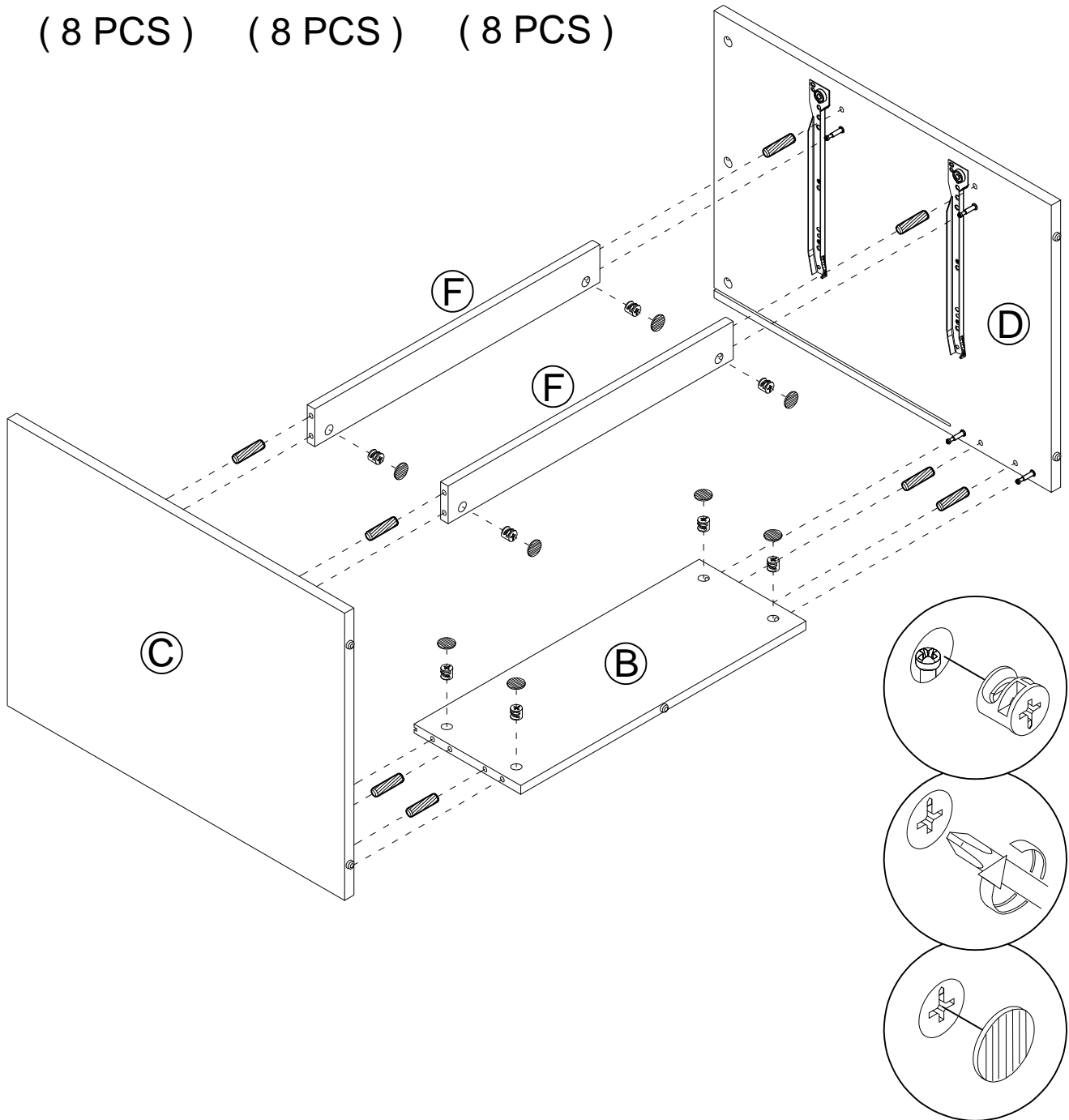
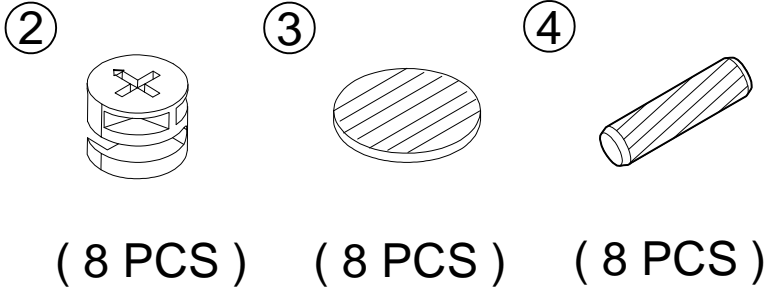

Step 3:

* Insert the BACK UPPER PANEL (E) to the stand.

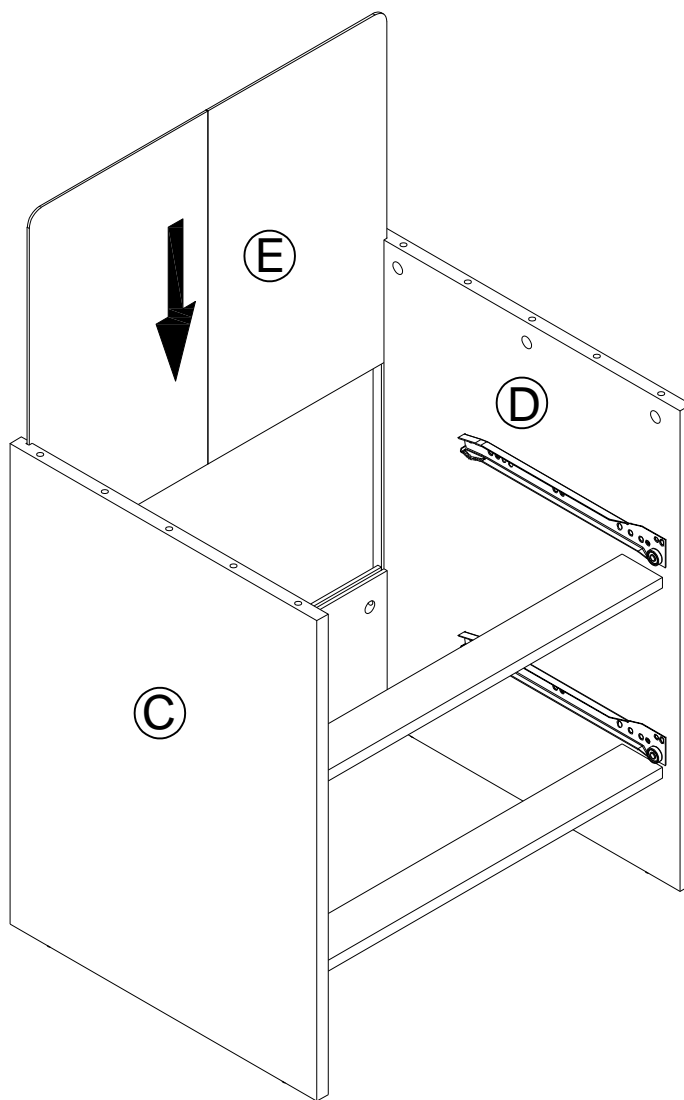

Step 4:

* Attach the TOP PANEL (A) to the Two the CURVED BAR (G) by the Six KD LARGE CAM (2) , Six COVER CAP (3) and Four WOOD DOWEL (4) .

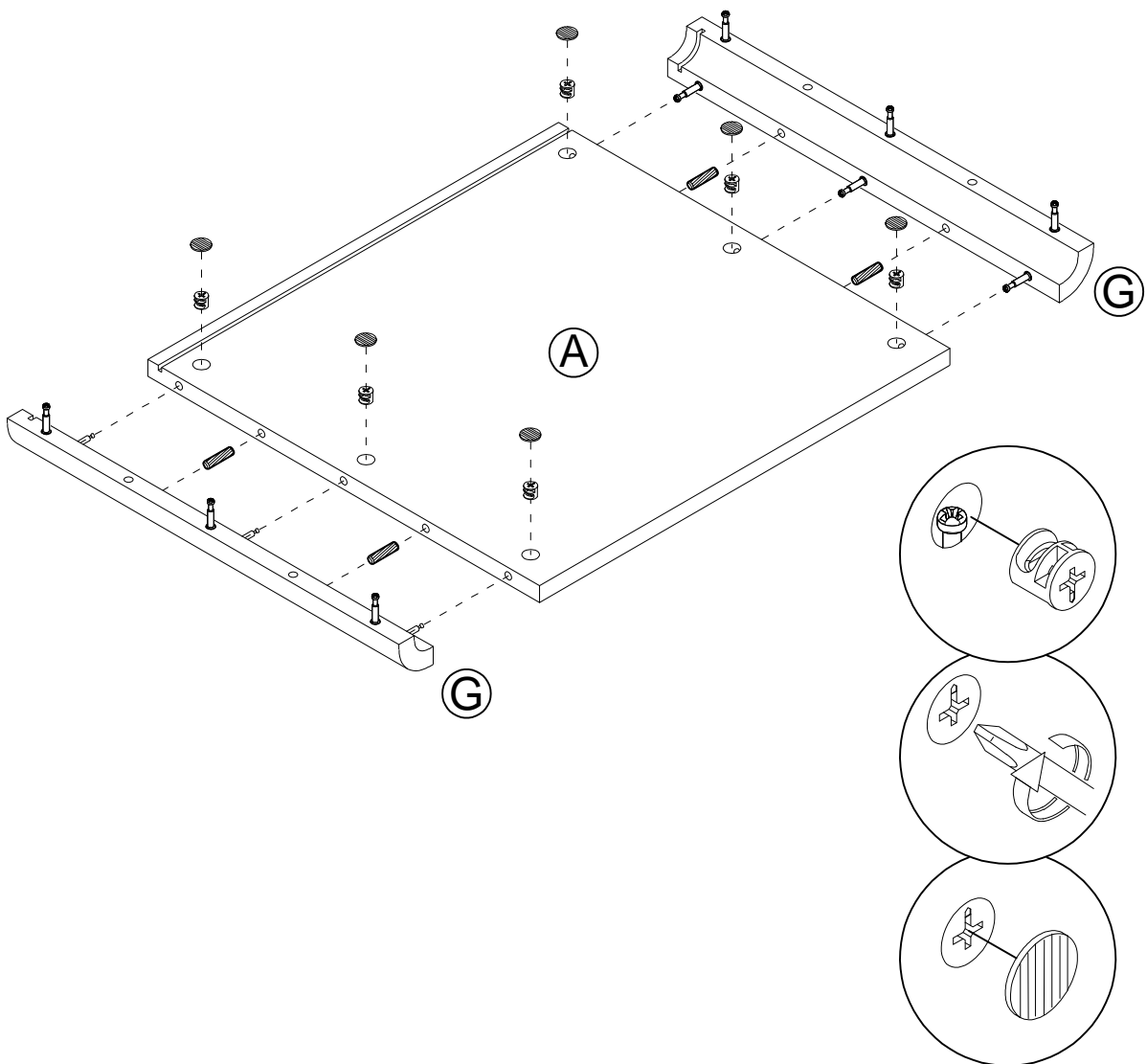
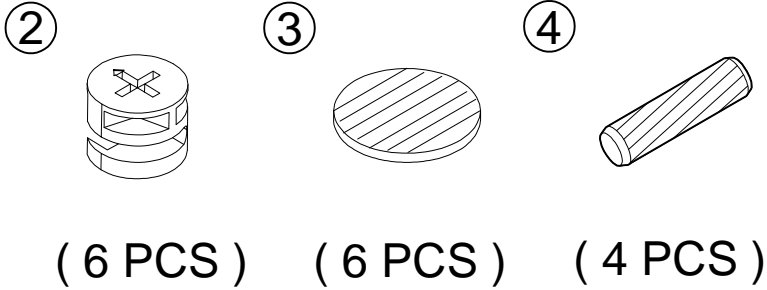

Step 5:

* Attach Two the CURVED BAR (G) to the LEFT PANEL (C) and RIGHT PANEL (D) by the Six KD LARGE CAM (2) , Six COVER CAP (3) and Four WOOD DOWEL (4) .

②

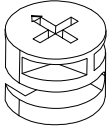

(6 PCS)

③

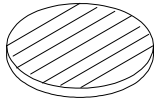

(6 PCS)

④

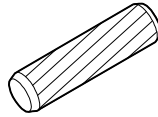

(4 PCS)

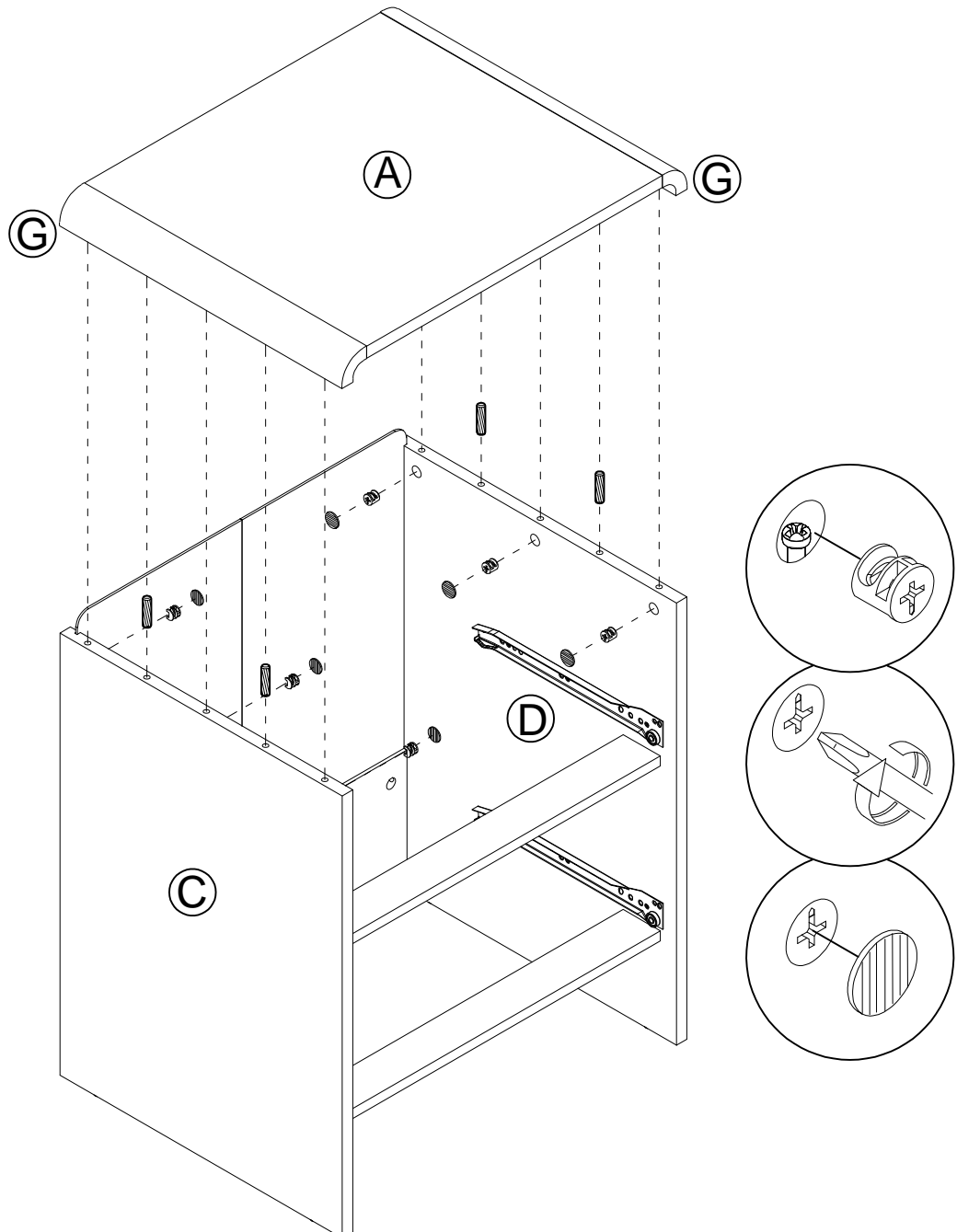

Step 6:

* Insert Ten PLASTIC WEDGE(7) and Eight SCREW(8) to the BACK UPPER PANEL (E).

⑦

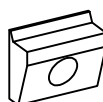

(10 PCS)

⑧

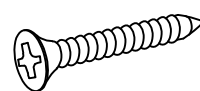

(10 PCS)

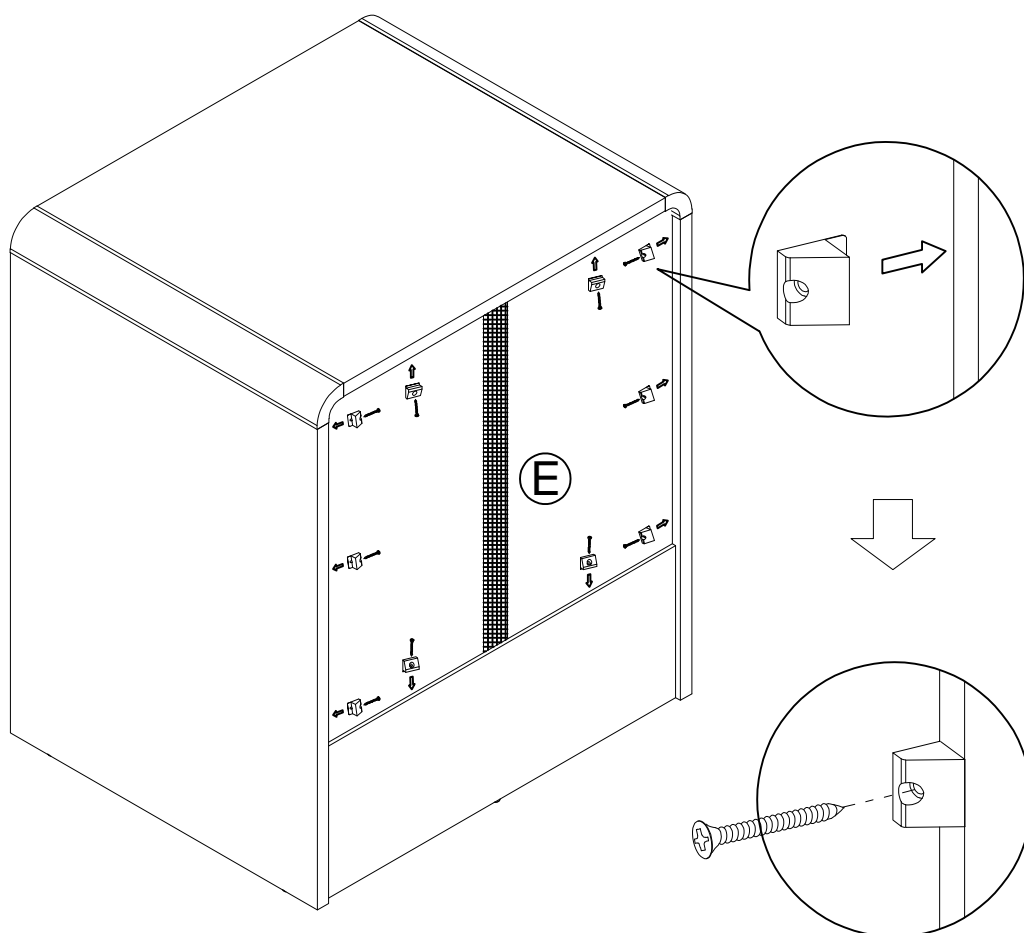

Step 7:

* Assemble the DRAWER BACK PANEL (J) to the DRAWER LEFT PANEL (H) and DRAWER RIGHT PANEL (I) by the SCREW (6) .

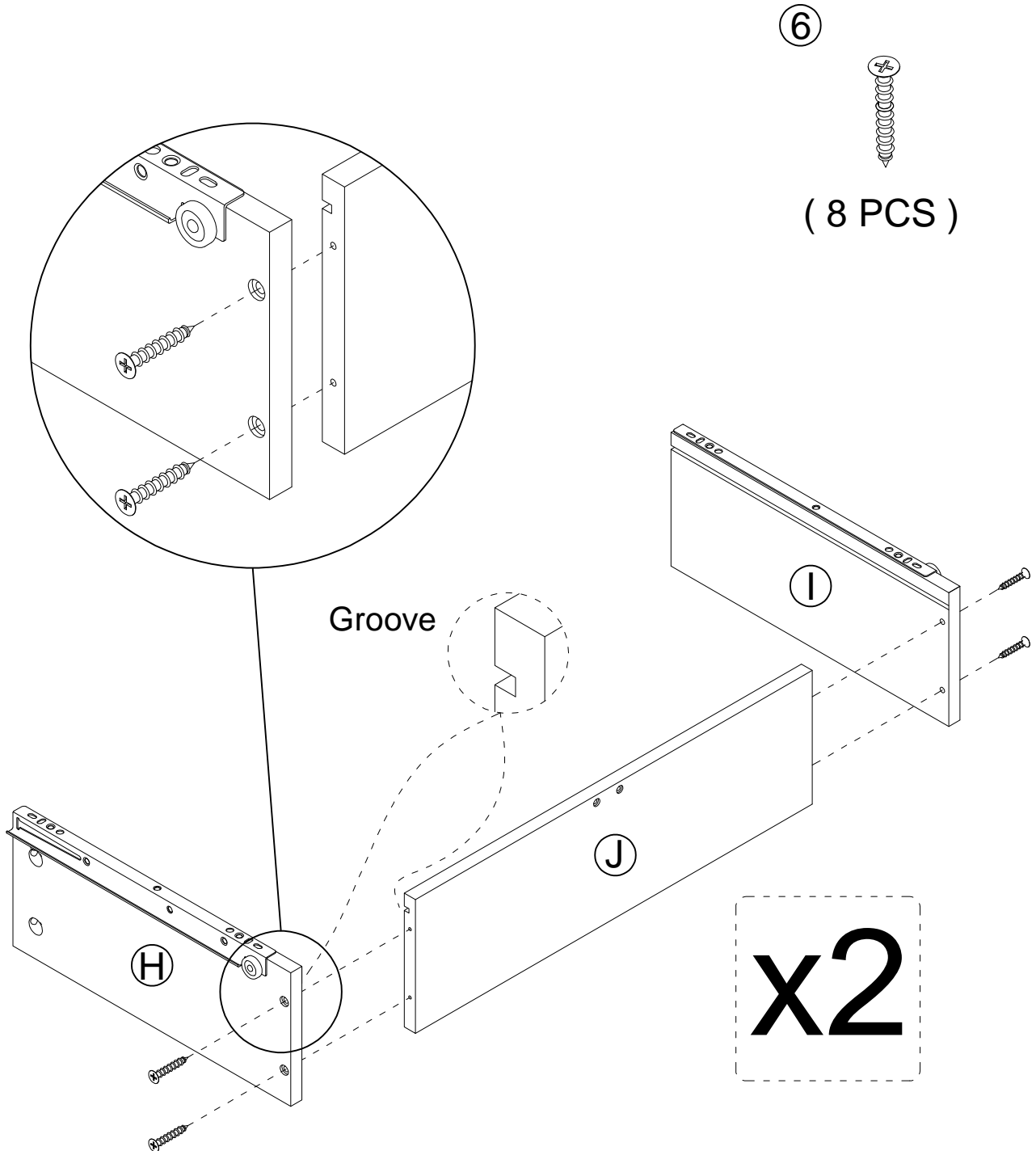

Step 8:

- * Slide in the DRAWER BOTTOM PANEL (K).
- * Assemble the DRAWER SUPPORT PANEL (L) to the DRAWER TRAY by the SCREW (6) .

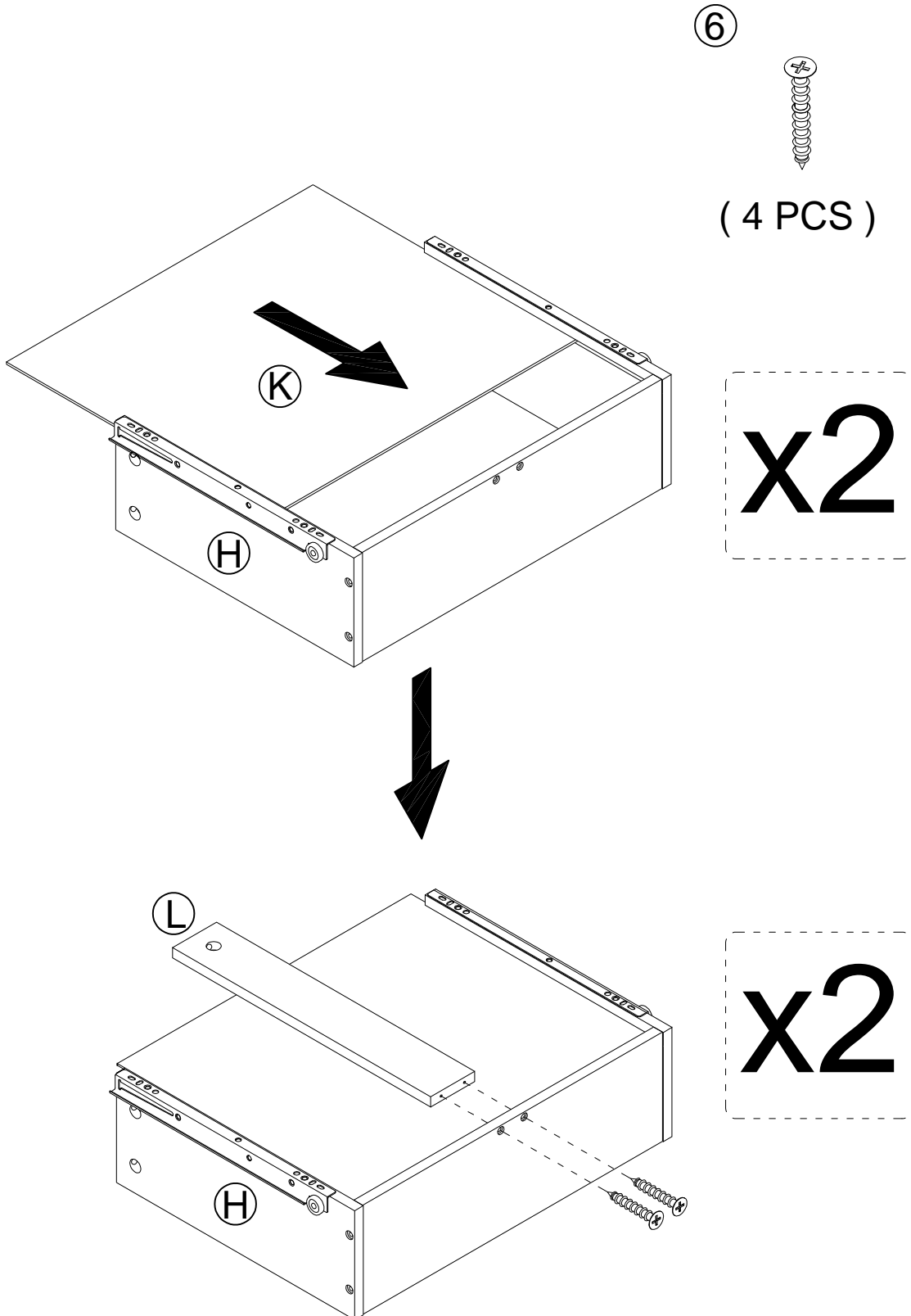

Step 9:

* Insert Ten KD BOLT (1) to the DRAWER UPPER FRONT PANEL (M) and DRAWER LOWER FRONT PANEL (O).

* Assemble Two the HANDLE (N) to the DRAWER UPPER FRONT PANEL (M) and DRAWER LOWER FRONT PANEL (O) by the BOLT (9).

①

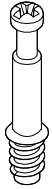

(10 PCS)

⑨

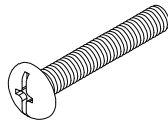

(4 PCS)

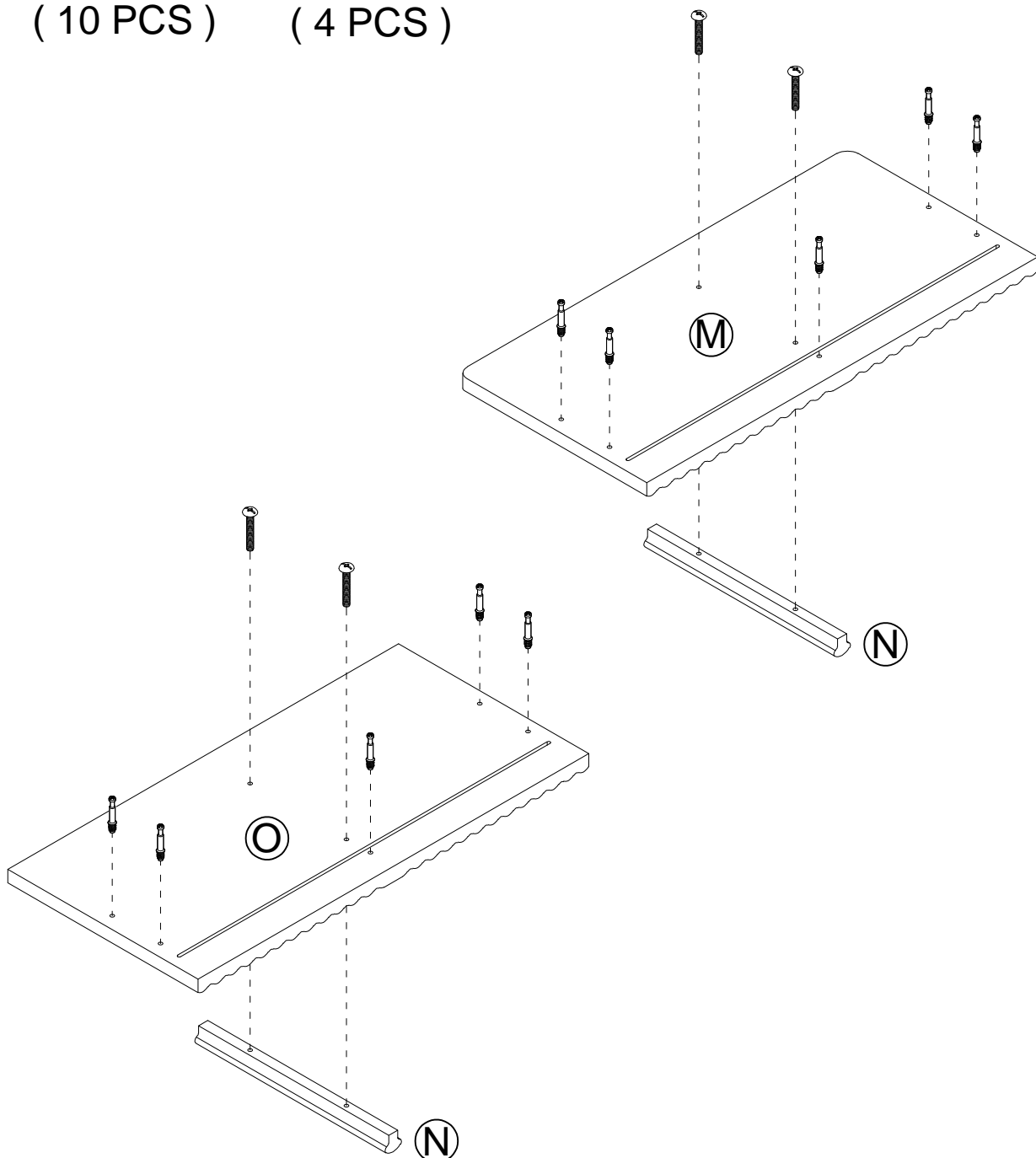

Step 10:

* Assemble the DRAWER UPPER FRONT PANEL (M) and DRAWER LOWER FRONT PANEL (O) to the DRAWER TRAY by the Ten KD SMALL CAM (5) and Ten COVER CAP (3).

⑤

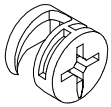

(10 PCS)

③

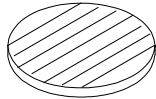

(10 PCS)

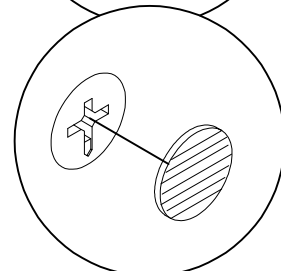
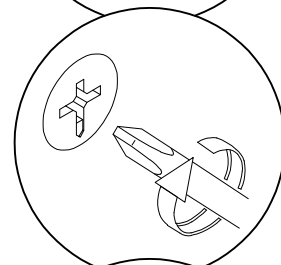
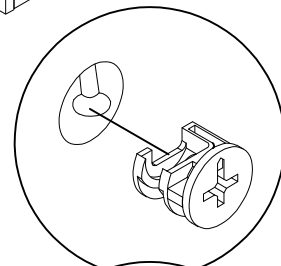
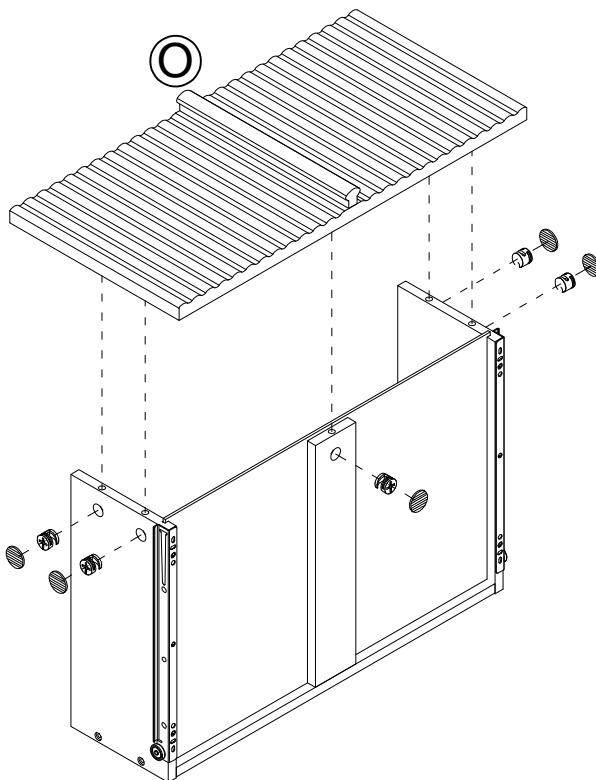
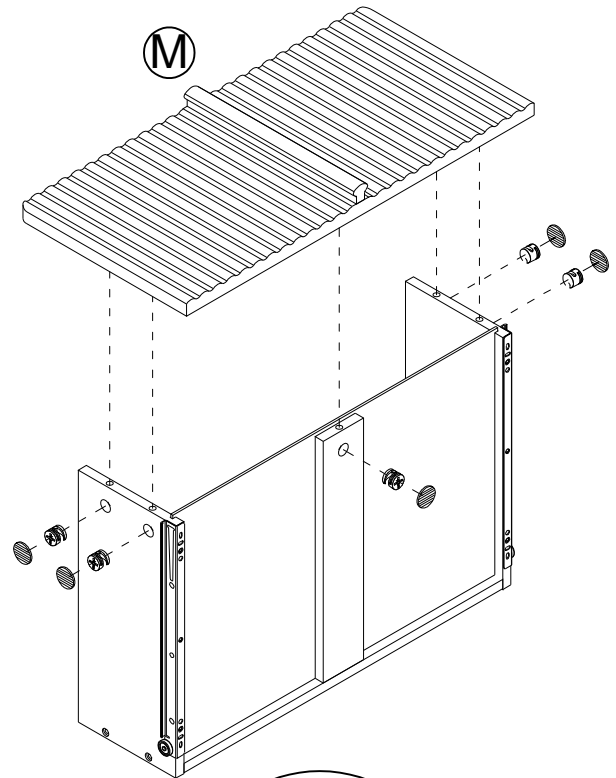

Step 11:

*Input Drawer tray to the stand.

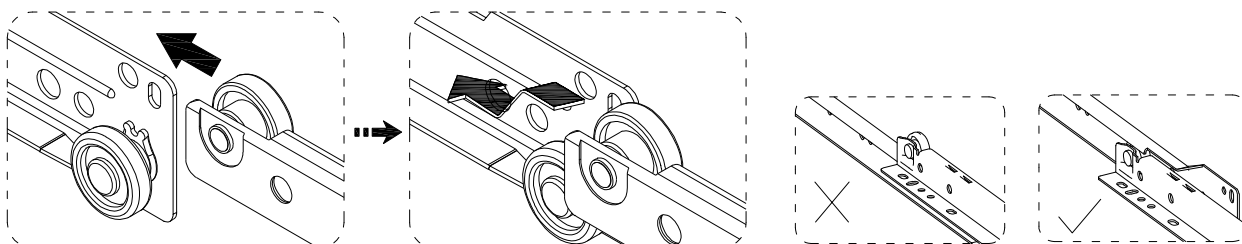
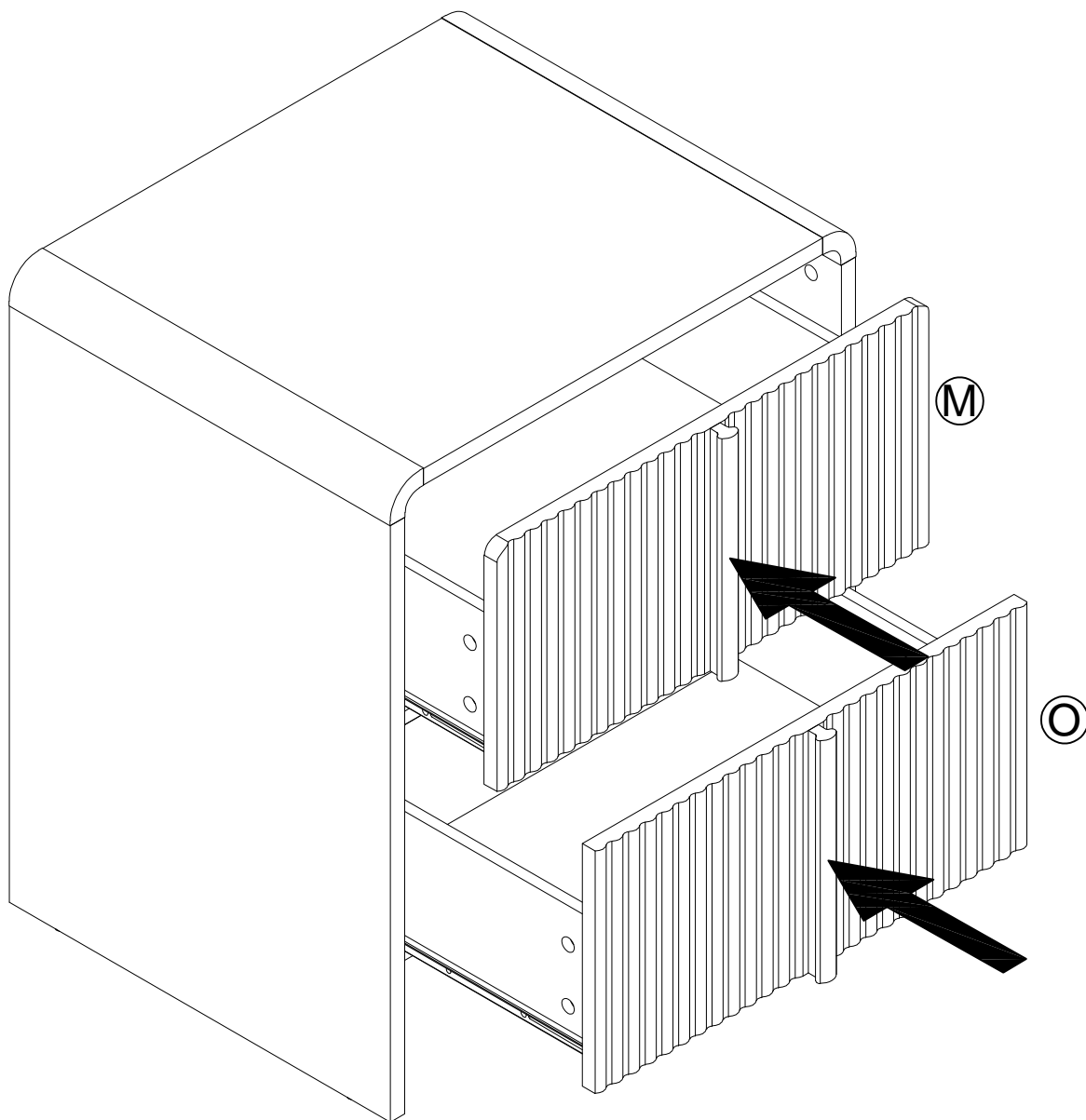



WARRANTY POLICY

All Manhattan Comfort furniture products are warranted, to the original purchaser at the time of purchase and for a period of 30 days thereafter.

Our warranty is limited to new products purchased in factory sealed cartons. This warranty is valid in the United States of America and Canada.

In order to provide you with timely assistance, please thoroughly inspect your furniture for missing or defective parts immediately after opening the carton.

Manhattan Comfort offers a 30-day parts replacement warranty on all items.

Our furniture products are not intended for outdoor use.

THE WARRANTY DOES NOT COVER:

- Defects/damages by improper assembly or disassembly.
- Defects/damages caused by shipping. Claims for damage during transit should be placed immediately to the transportation company.
- Defects/damages caused by inappropriate use of the furniture.



319 Ridge Rd. Dayton, NJ 08810

908-888-0818