

ASSEMBLY STRUCTURE REFERENCE DIAGRAM

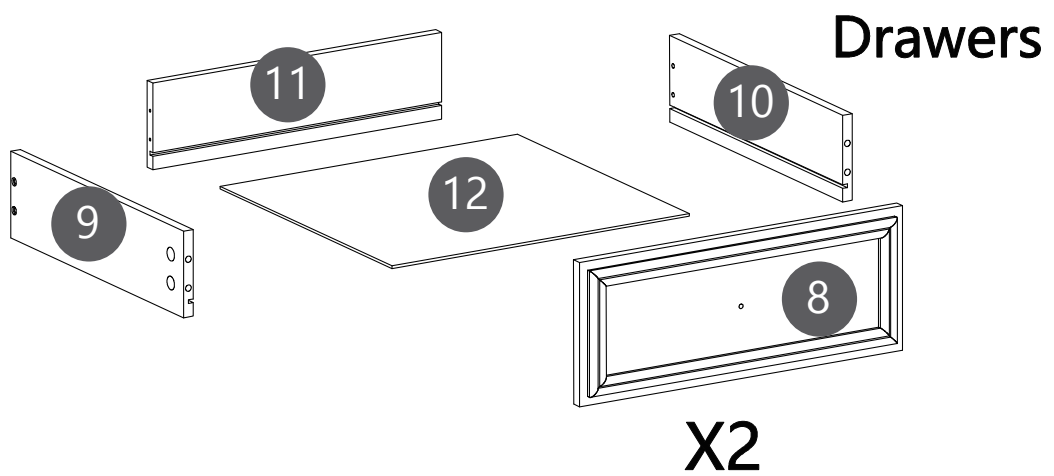

PARTS

A

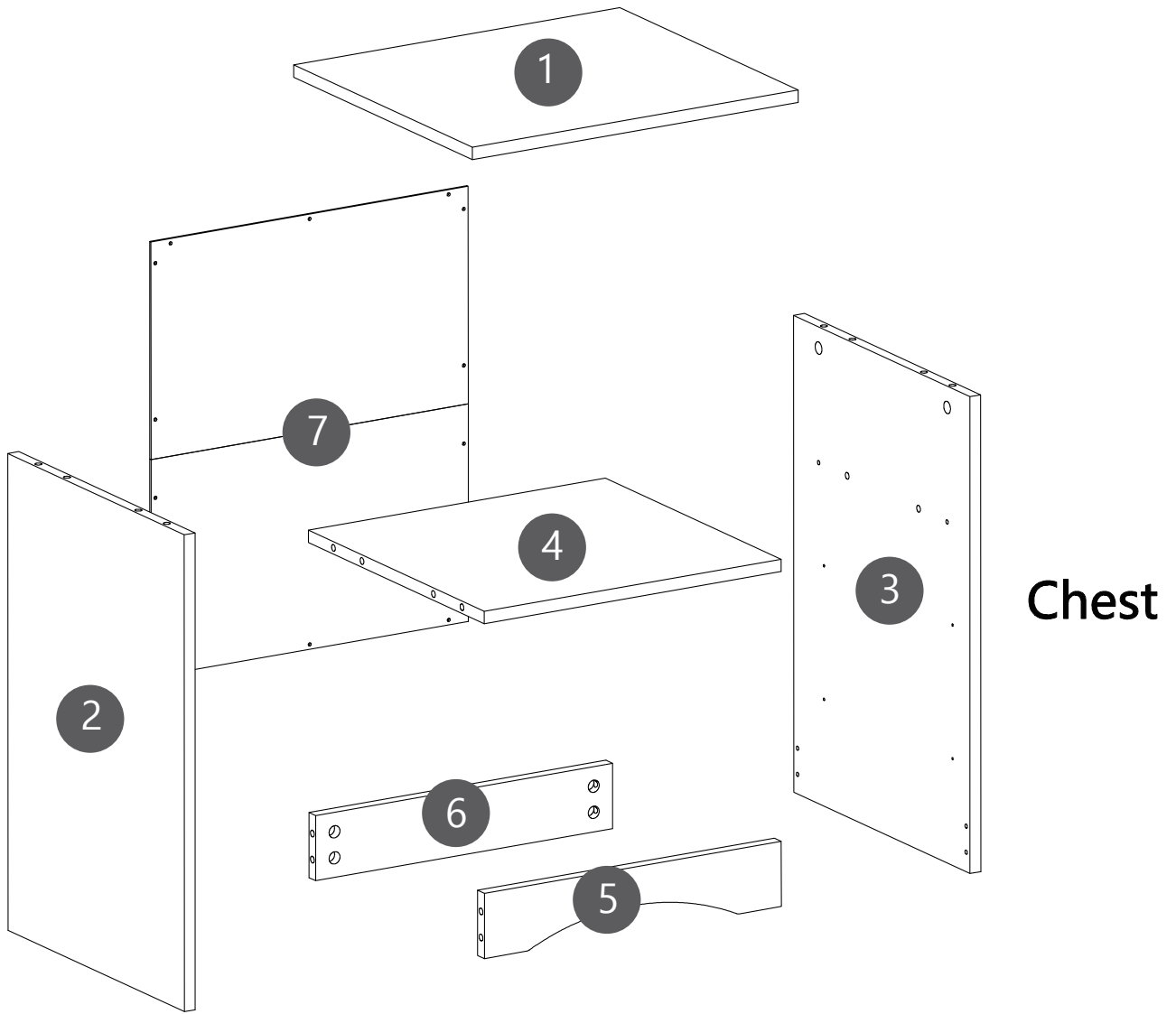
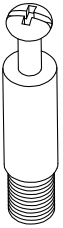

X 24+1

B

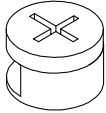

Ø15 x 9mm
X 24+1

C



Ø8 x 30mm
X 8+1

D



Attention: there are 4 kinds of slides in our product, in which 2 are **Boards slides**, which marked as **CL & CR** and contains 2 pieces respectively, and the other 2 are the **Drawer slides**, which marked as **DL & DR** and contains 2 pieces respectively.

E

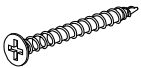

Ø3.5 x 35mm
X 8

F



Ø3.5 x 12mm
X 24+1

G



Ø3.5 x 12mm
X 14+1

H

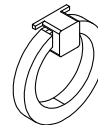

X 2

I

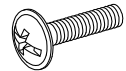

M4 x 16mm
X 2

The hardware quantities listed above are required for proper assembly. Some extra hardware may also have been included.

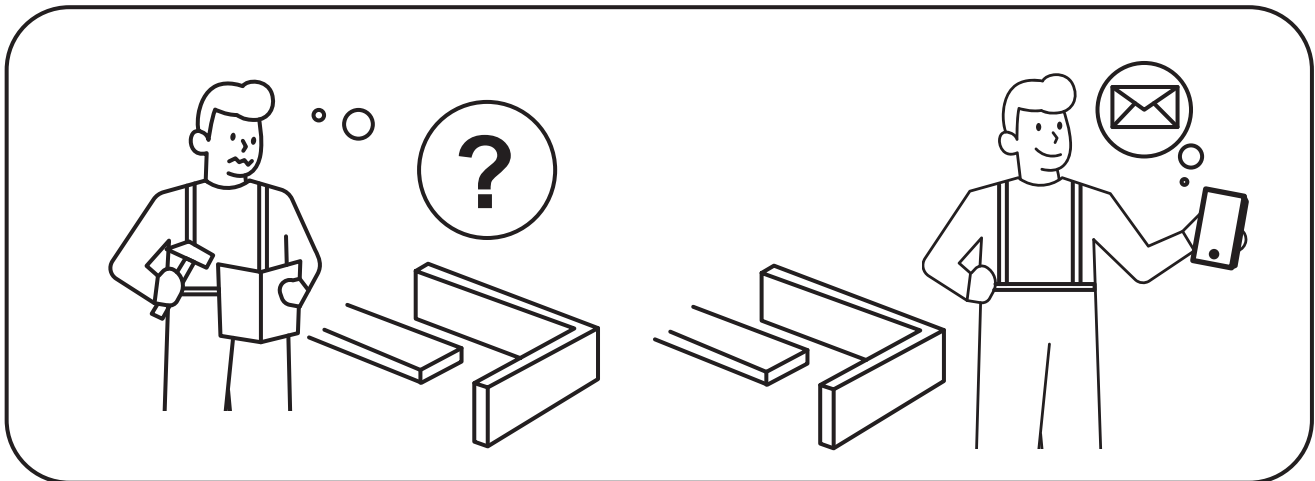
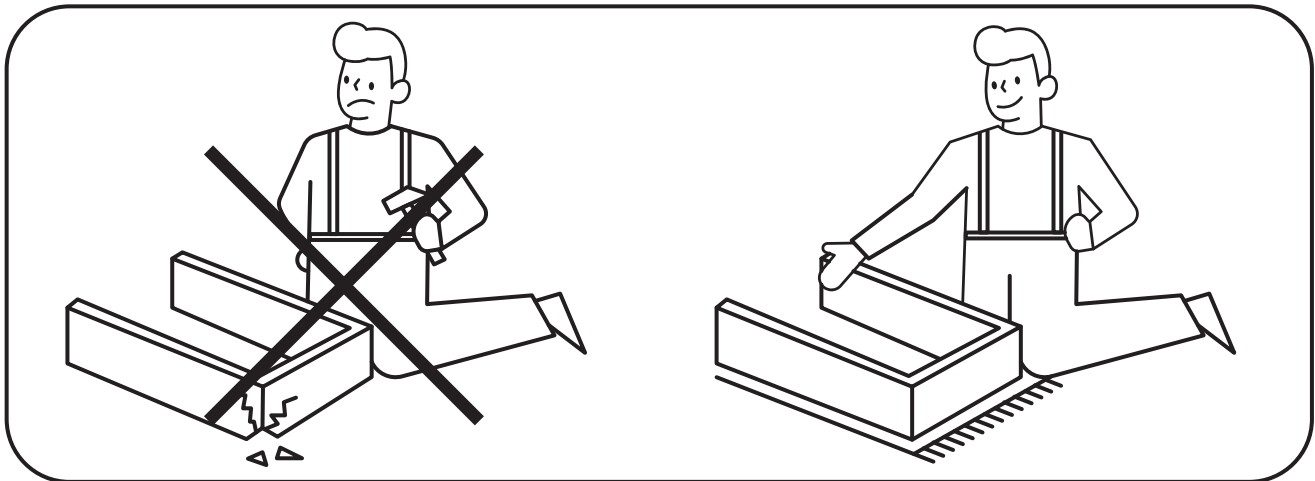
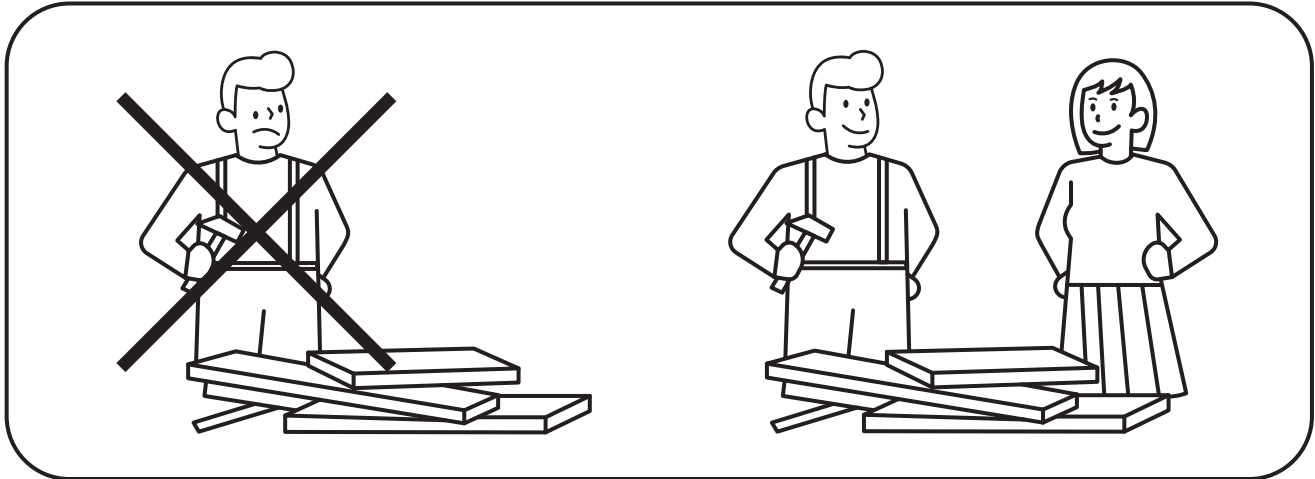
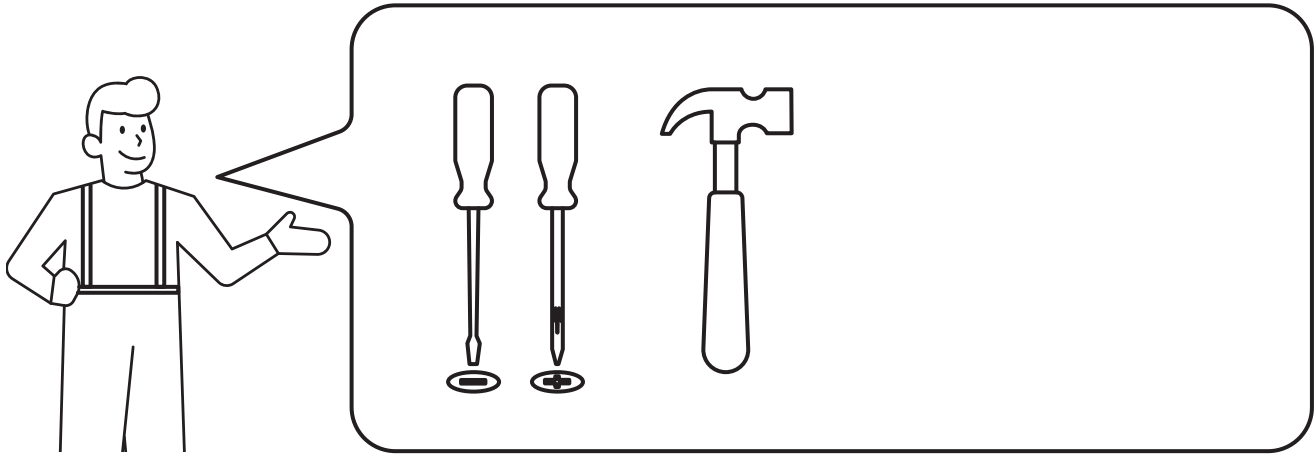

How to work the Knock Down (kd) assembly system

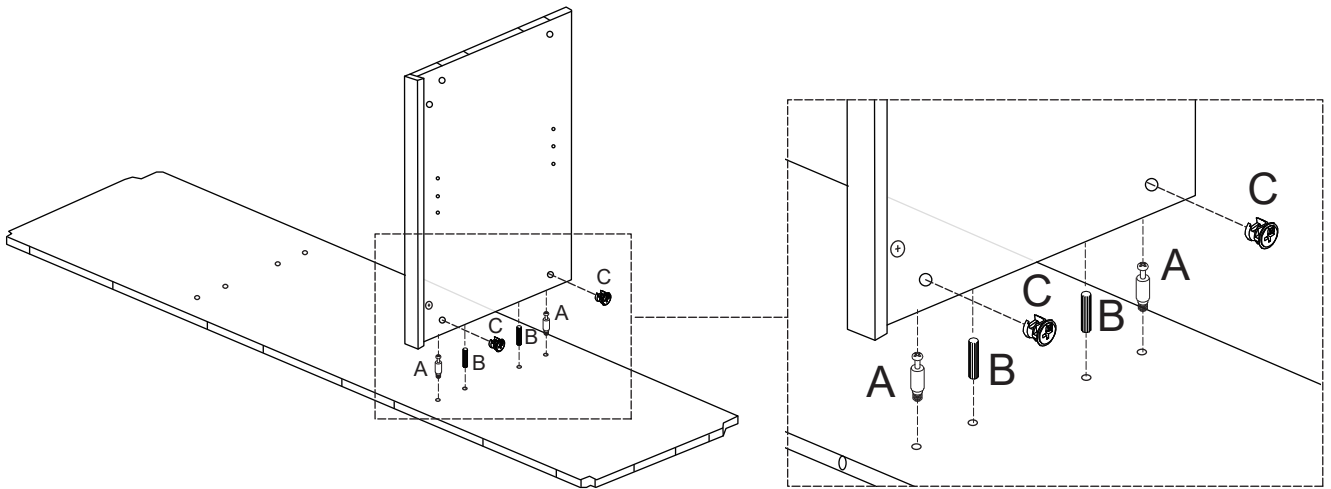

How to install Wood Dowel

Insert the wood dowel [B] at least half way by tapping lightly with a rubber mallet, IF NECESSARY.

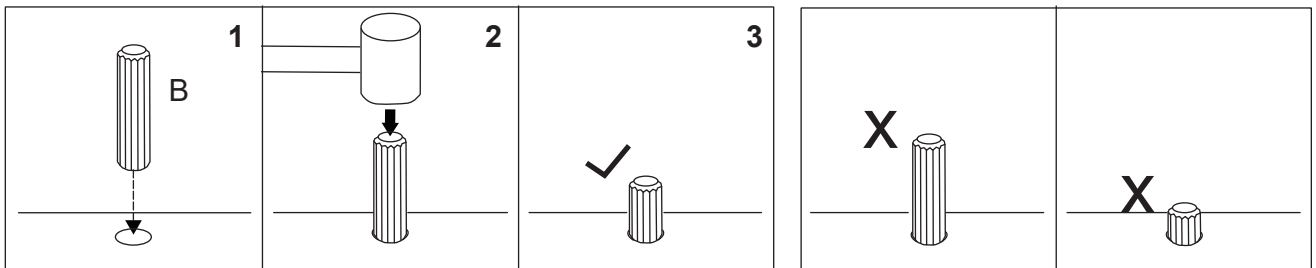

How to use the Cam Lock system

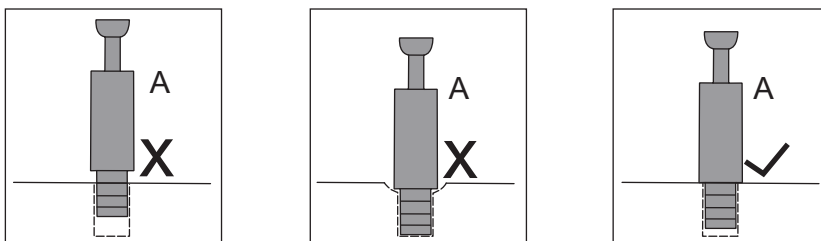

1. Screw the cam bolt [A] into the threaded insert on the panel.
2. Connect both panels together making sure cam bolt [A] goes into the pre-drilled large hole on the end of panel for cam lock [C].
3. Insert the cam lock [C] into the pre-drilled large hole on the panel. **Make sure the cross slot of cam lock [C] faces out.**
4. Rotate the cam lock [C] **clockwise** with a self-supplied philips screwdriver to lock the cam bolt [A] in place.

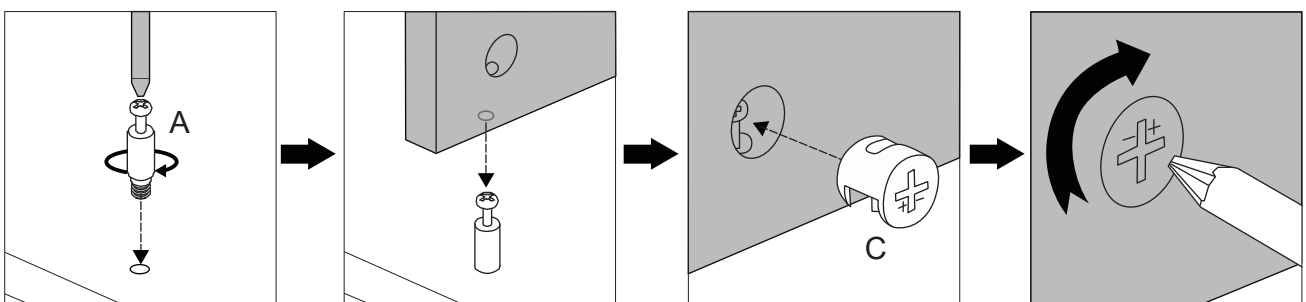

Before installing the product, observe the general structure.
It is divided into 5 parts in total:

1. Install the Boards and Slides(②&③&④&⑤&⑥)
2. Install the Top Panel (①)
3. Install the Back Panel (⑦)
4. Install the Drawers
5. Install the Drawers Slides

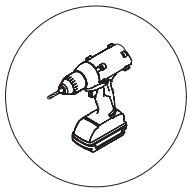

We recommend using a power drill to assemble.

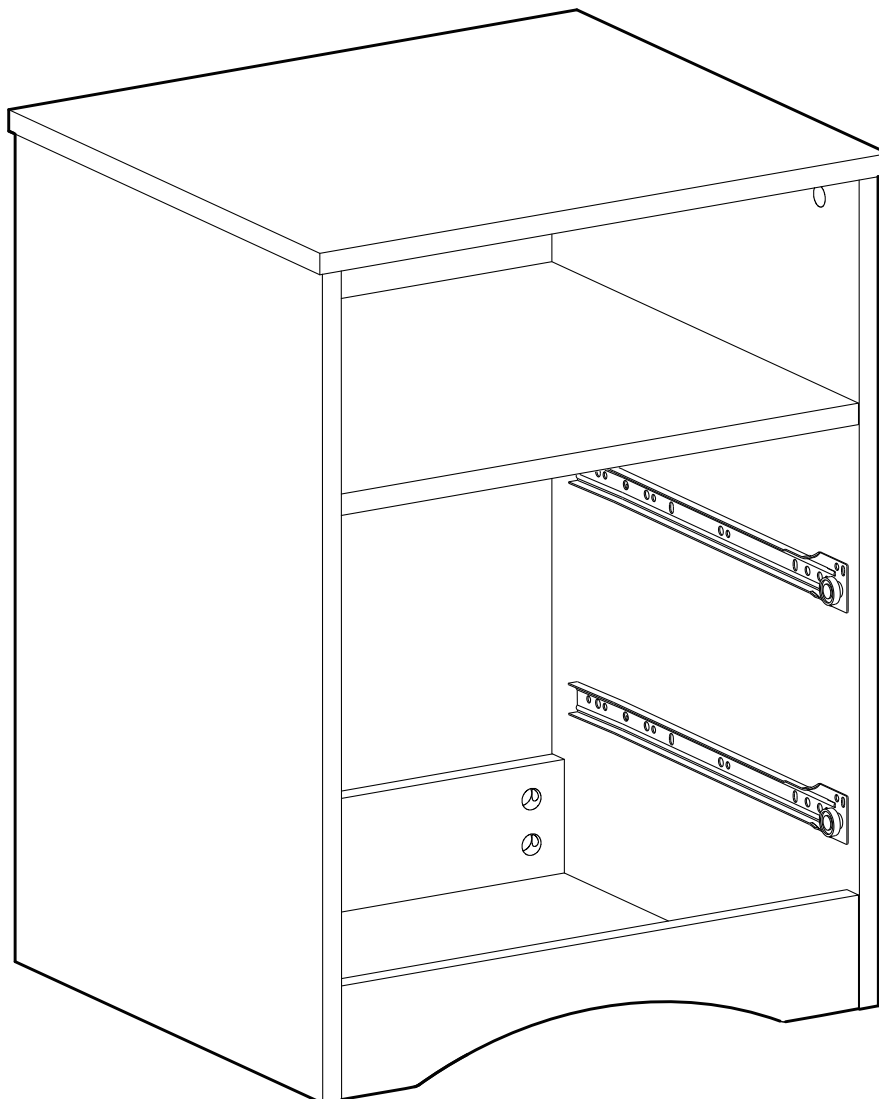

Step 1

Using Screws (F) to assemble Slide (CL) to Board (②).

Screwing one more screw in this position for reinforcement.

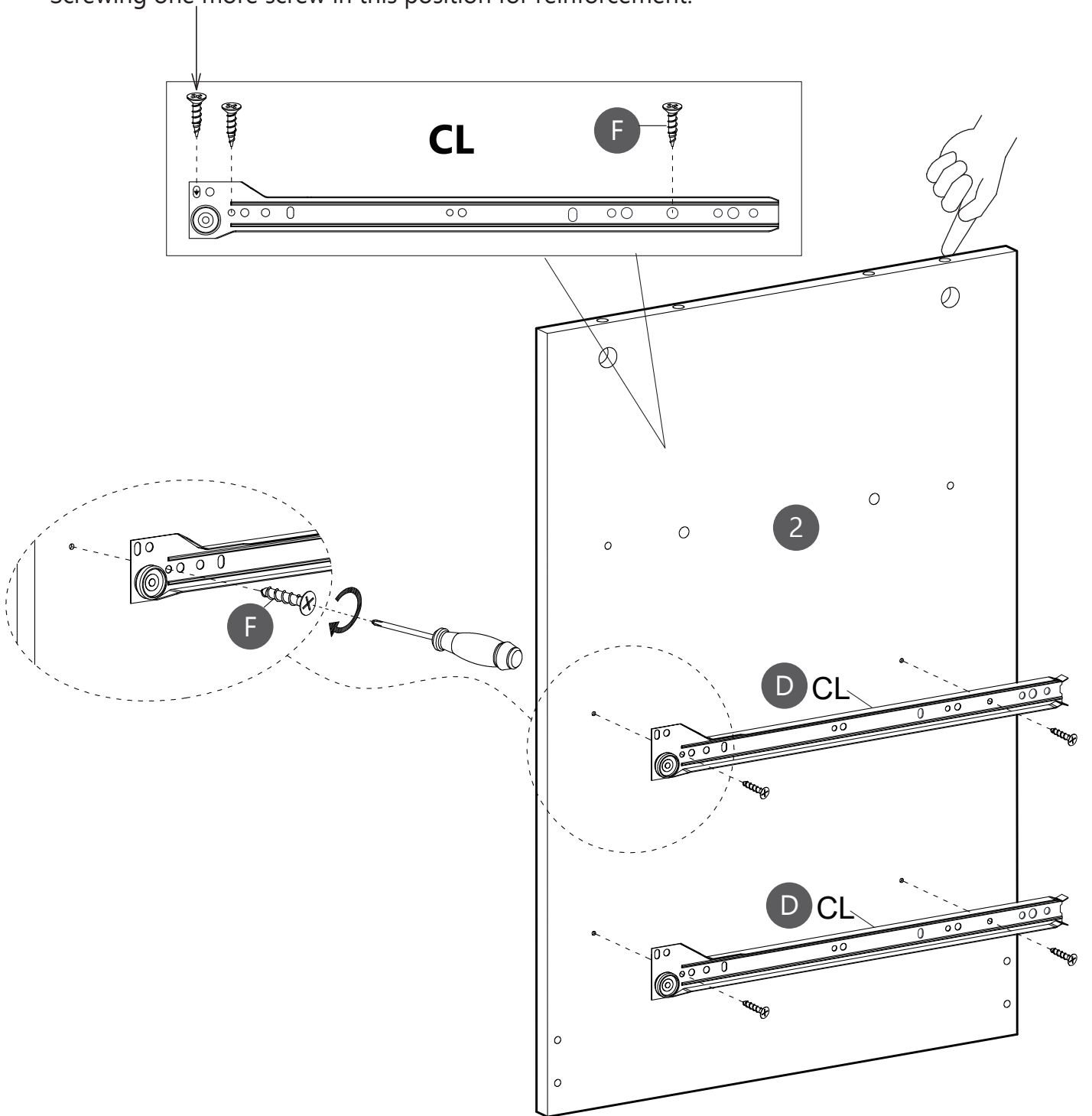

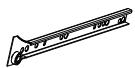

- | | | |
|---|---|--------|
| F |  | x 6 |
| D |  | CL x 2 |

Step 2

Using Screws (F) to assemble Slide (CR) to Board (③).

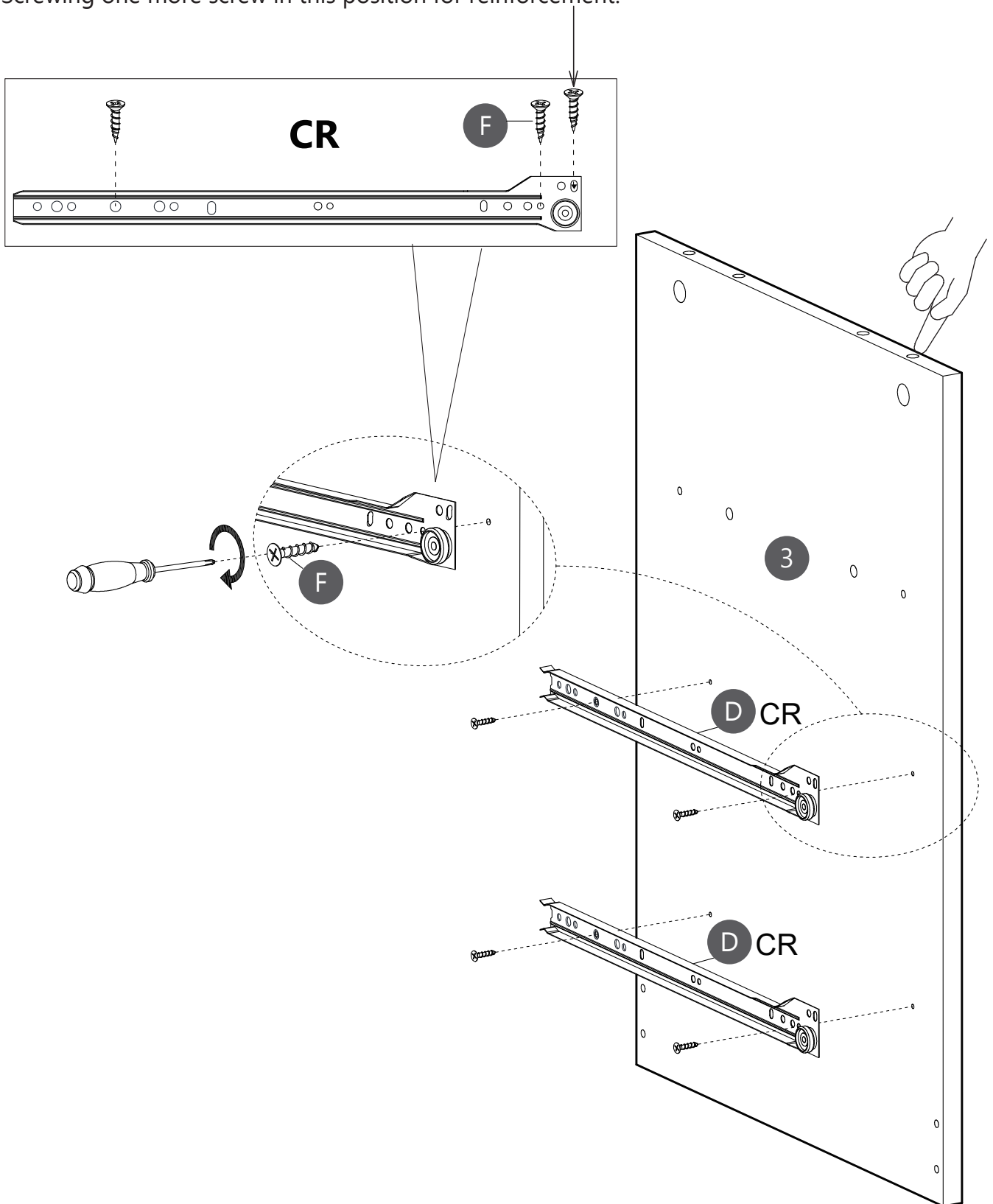
Screwing one more screw in this position for reinforcement.

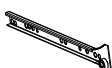

- F  x 6
- D  CR x 2

Display. Non-installation steps

Reference to the completion of the installation:
checking the position of the slides and screws in the board.

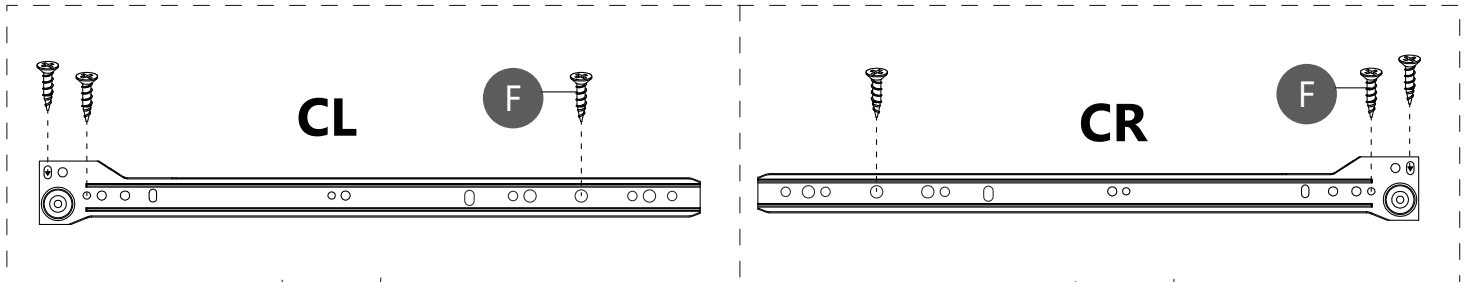

Please make sure the pre-drilled holes are on the top.

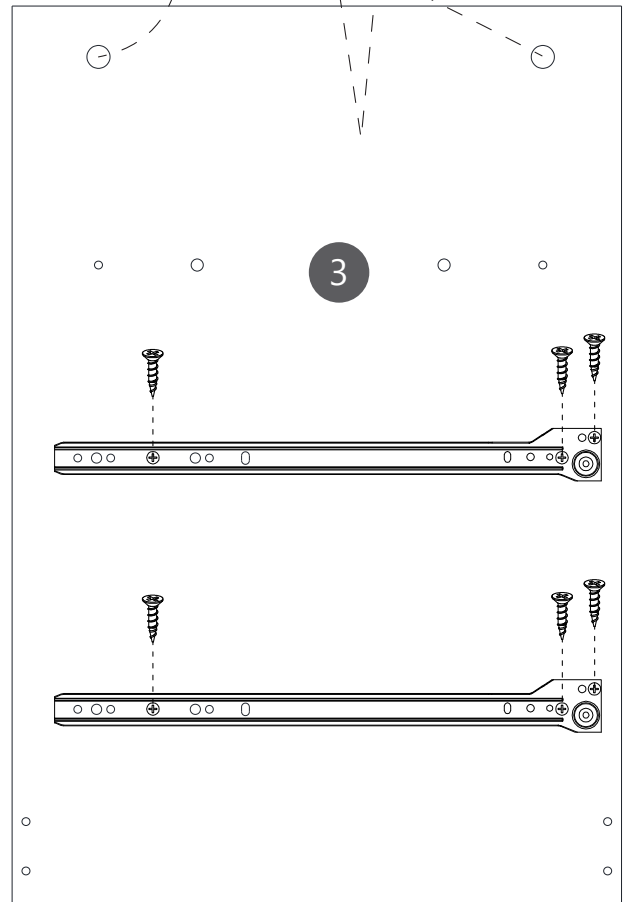
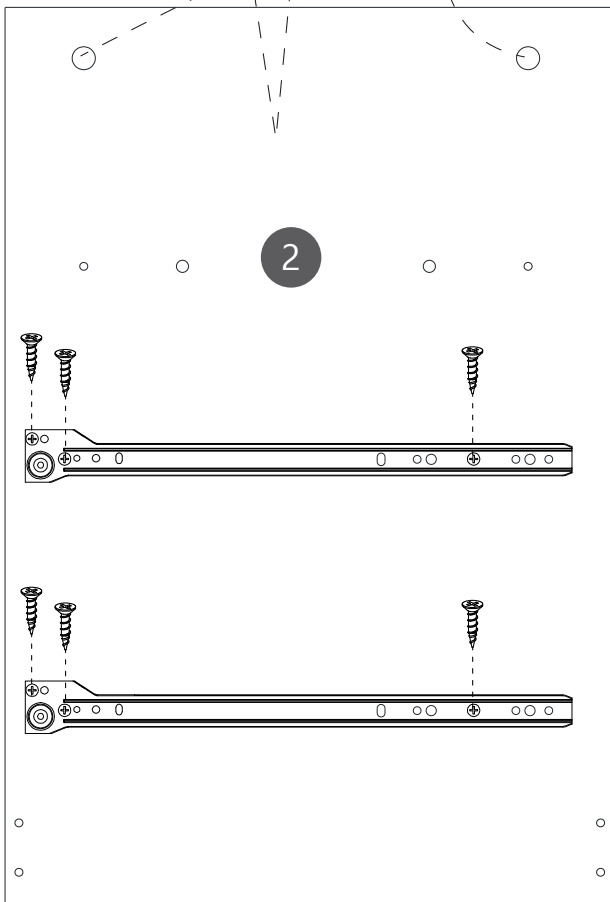

TIP: The screws for the slide must be tightened very tightly, and don't tilt the screws, otherwise the drawers will get stuck and won't fit in.

Step 3

Securing Cam Bolt (A) into Board (②&③).

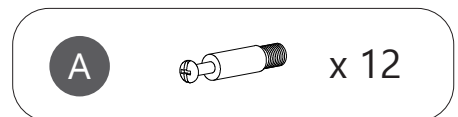
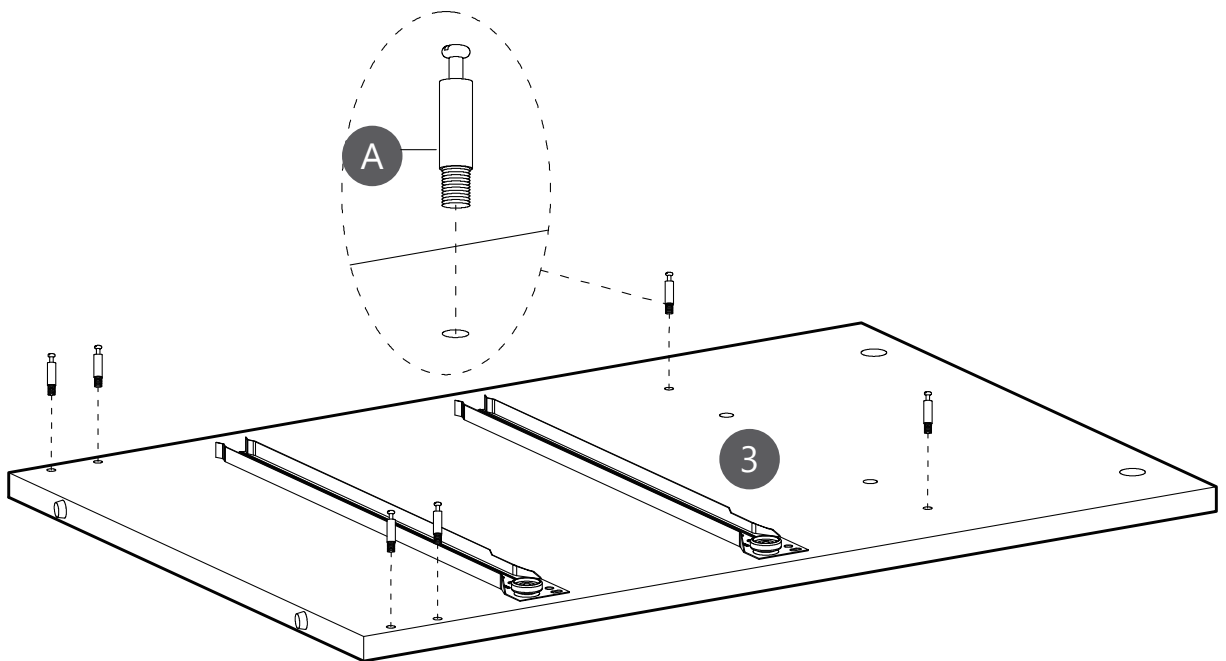
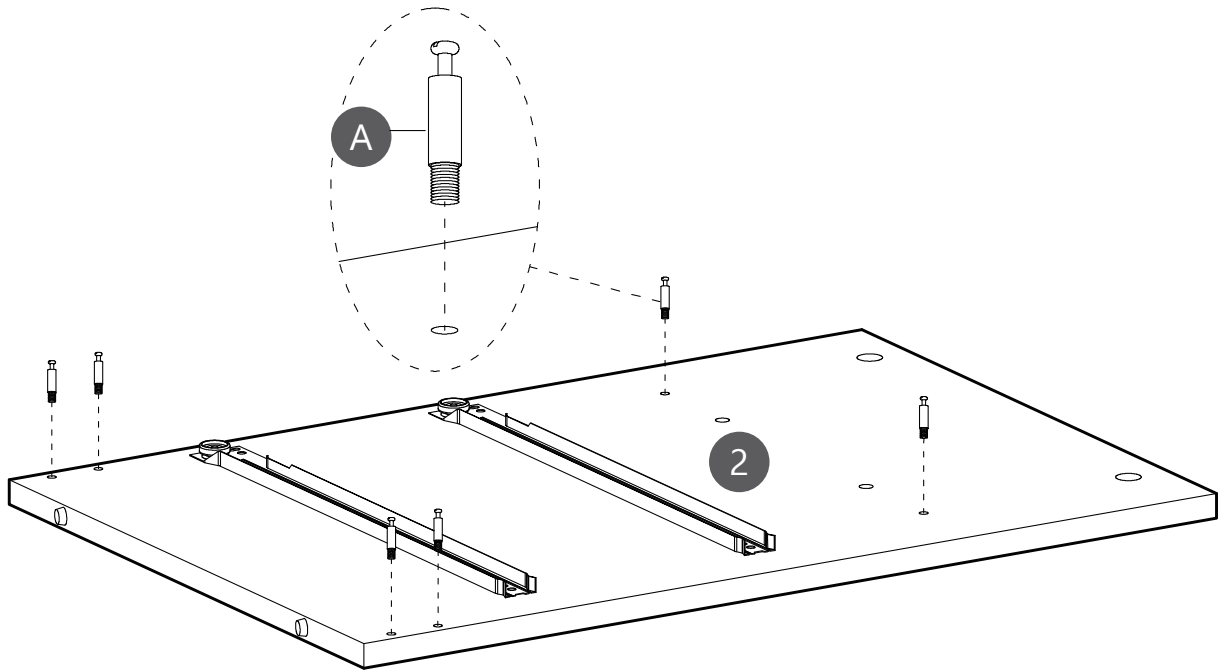

Step 4

Inserting Wooden Dowel (C) into Board (2), then attach Board (2) to Board (4).
Using Cam Lock (B) secure Board (2) to Board (4).

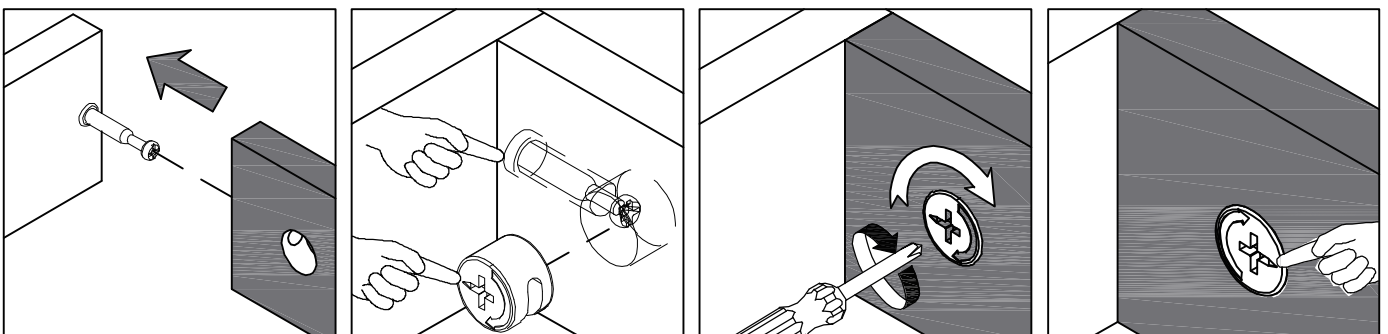
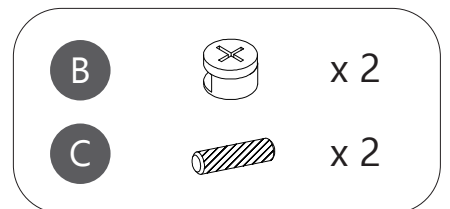
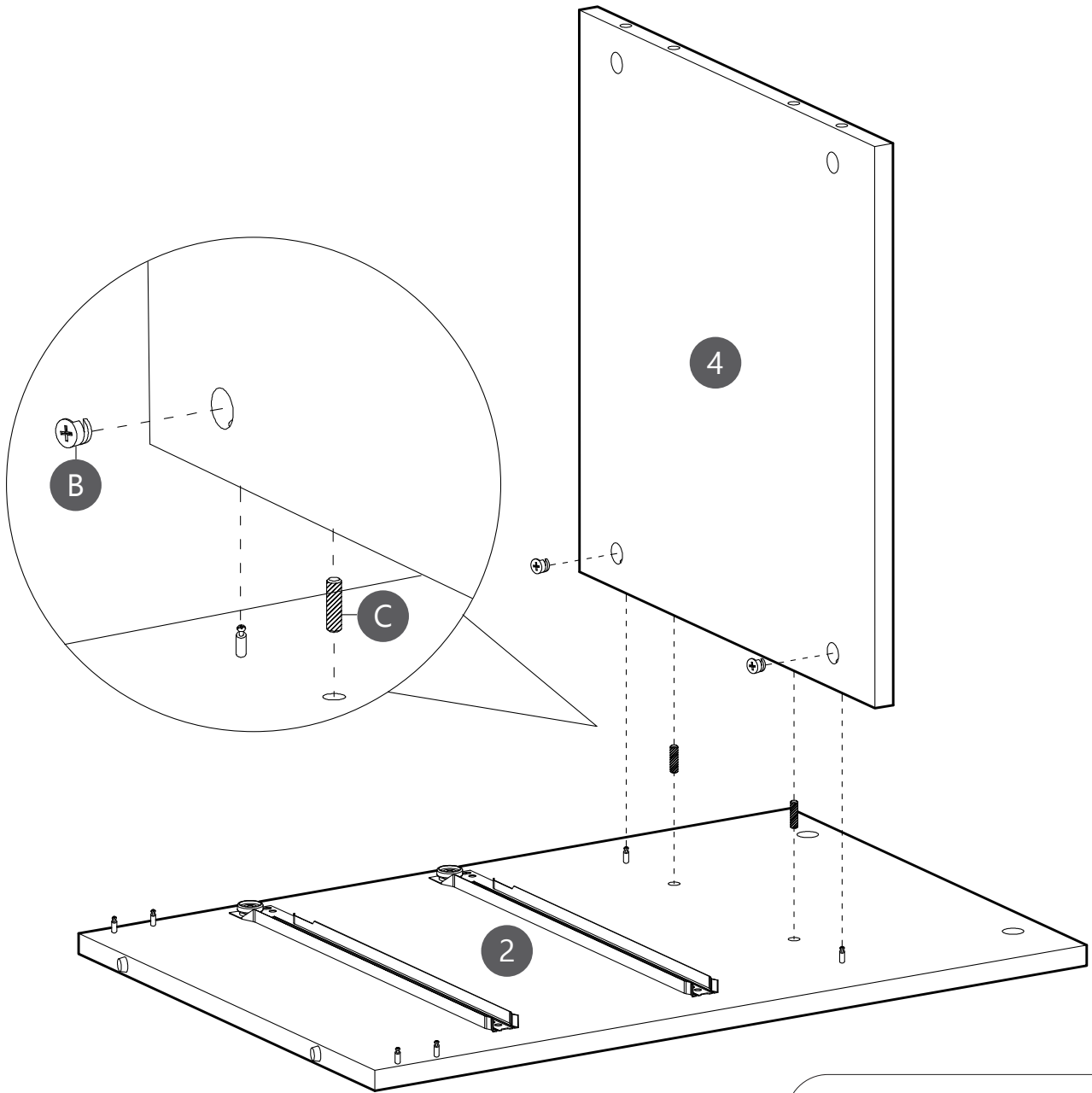

Step 5

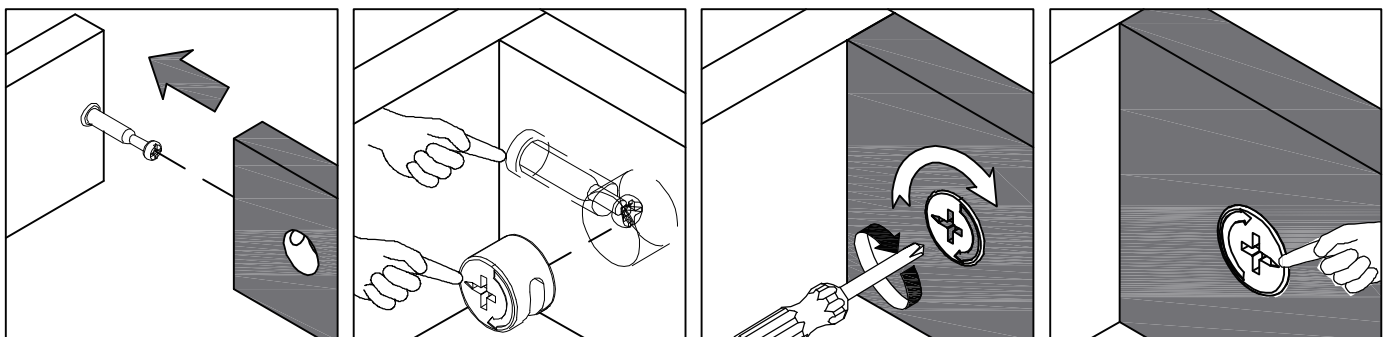
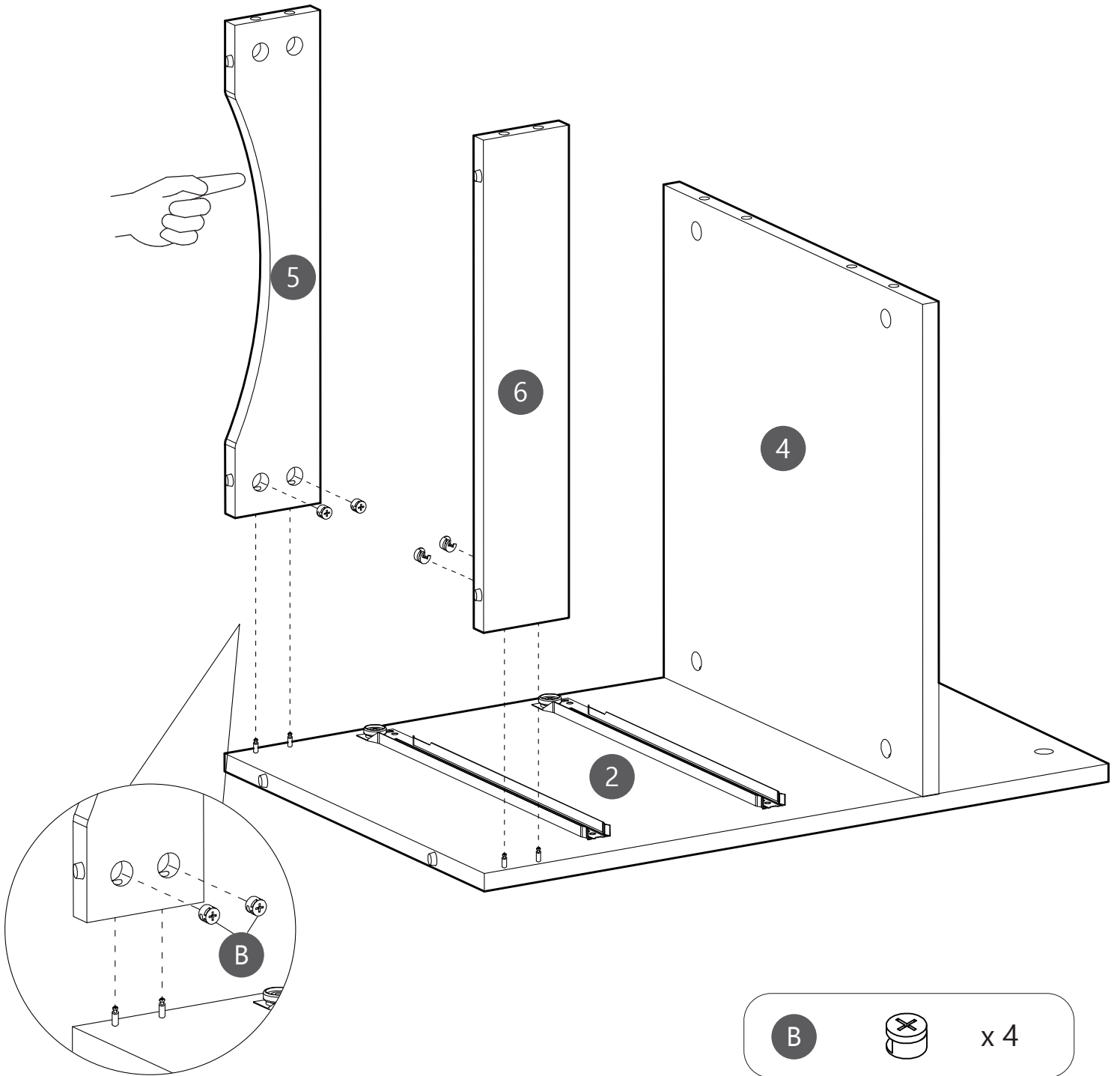

Attach Board (5&6) to Board (2). Using Cam Lock (B) secure Board (5&6) to Board (2).

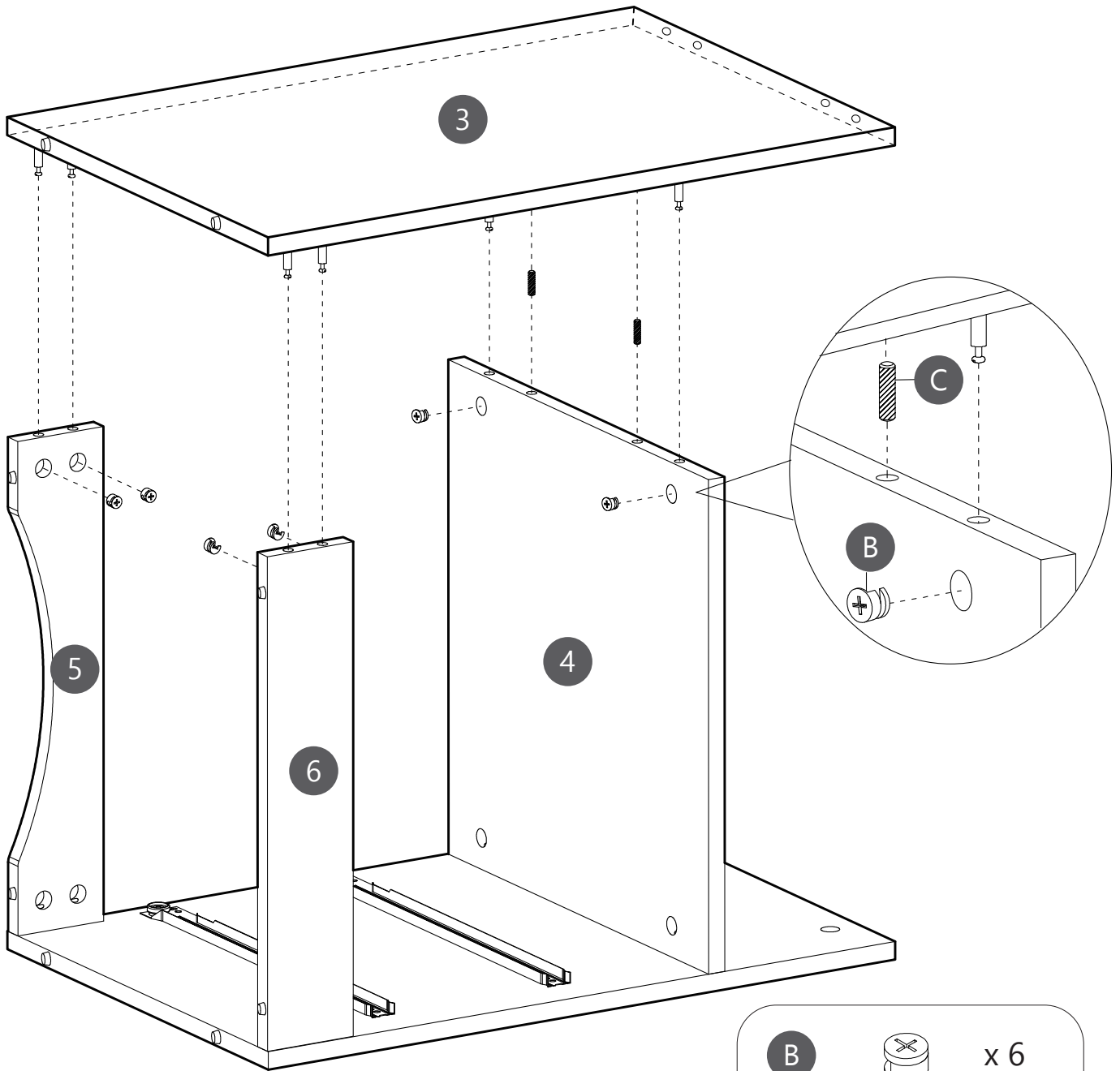

Step 6

Inserting Wooden Dowel (C) into Board (4), then attach Board (3) to Board (4&5&6).
Using Cam Lock (B) secure Board (3) to Board (4&5&6).



- | | | |
|---|---|-----|
| B |  | x 6 |
| C |  | x 2 |

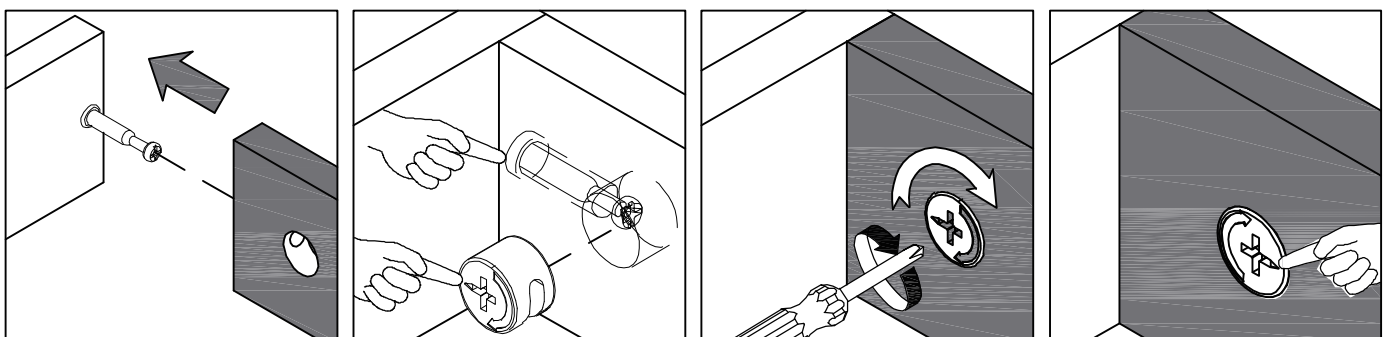

Step 7

Securing Cam Bolt (A) into Board (①).

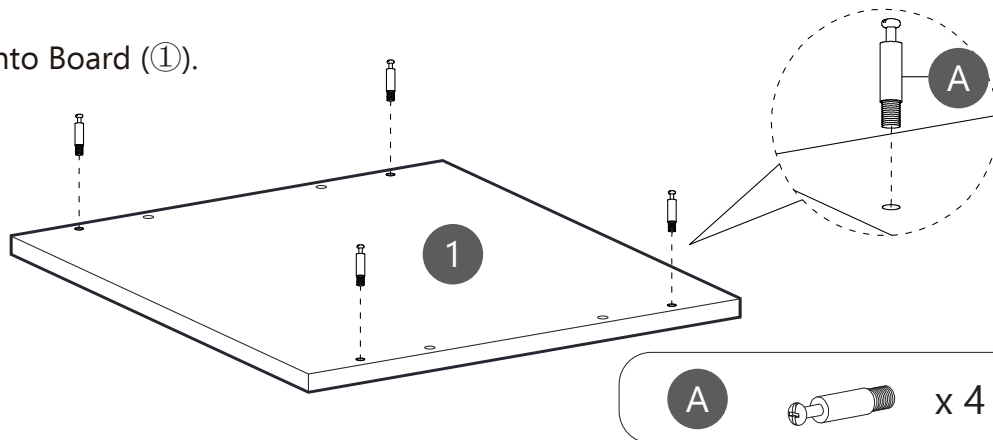

Step 8

Inserting Wooden Dowel (C) into Board (②&③), then attach Board (①) to Board (②&③). Using Cam Lock (B) secure Board (①) to Board (②&③).

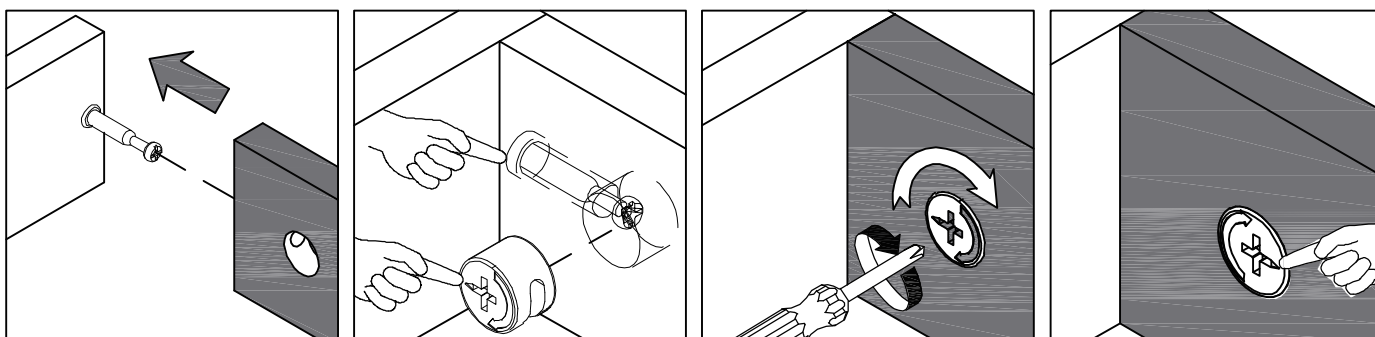
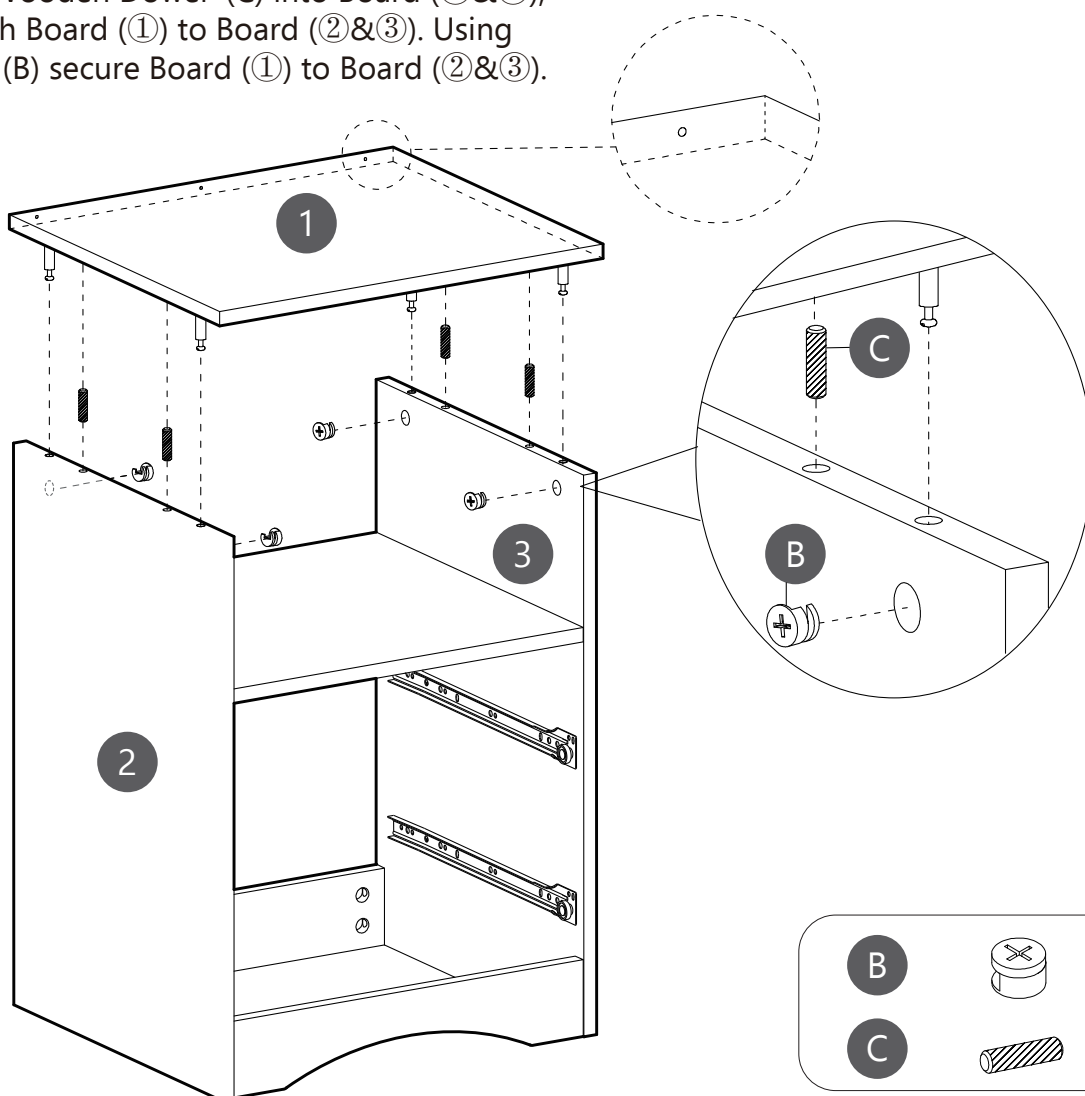

Step 9

Using Screws (G) assemble Back Panels (7) to the main body.

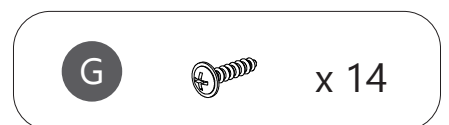
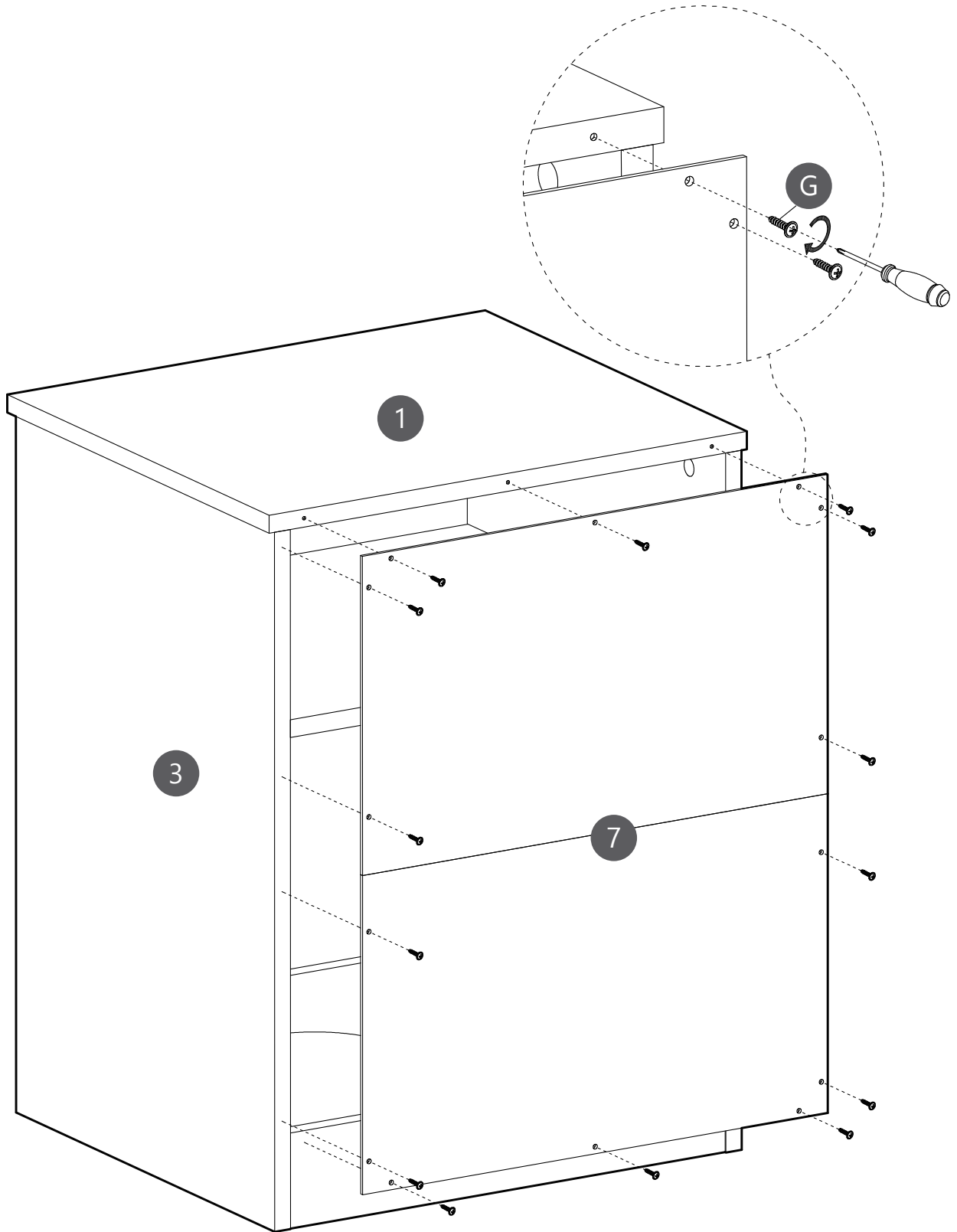

Step 10

Using Screws (E) to assemble Board (9&10) to the Board (11).

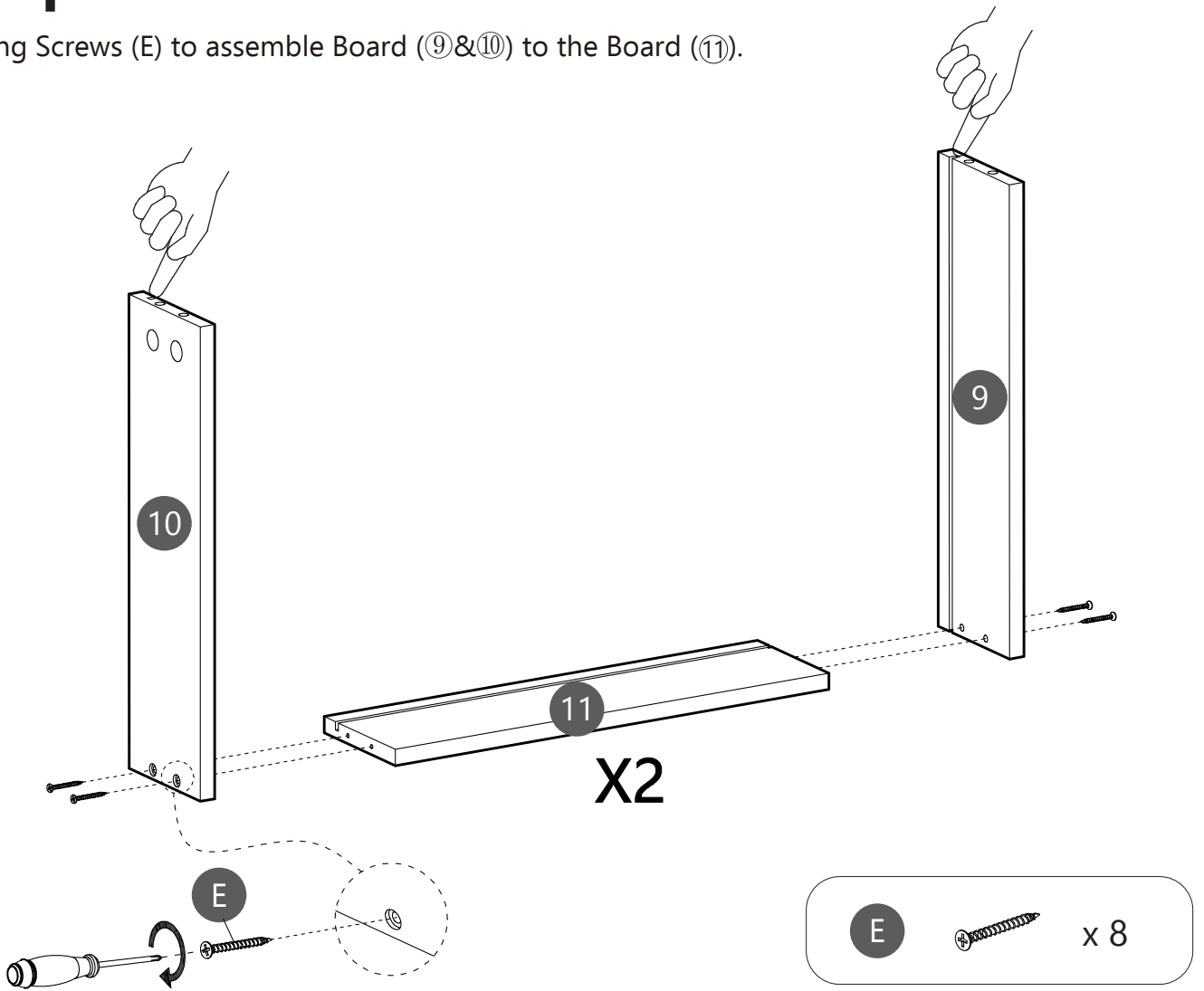

Step 11

Sliding drawer bottom panels (12) into grooves.

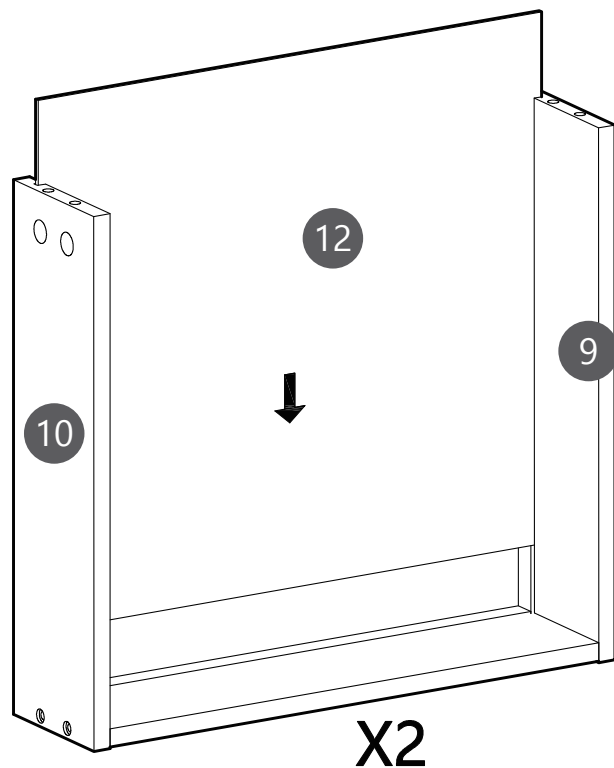

Step 12

Securing Cam Bolt (A) into Board (8).

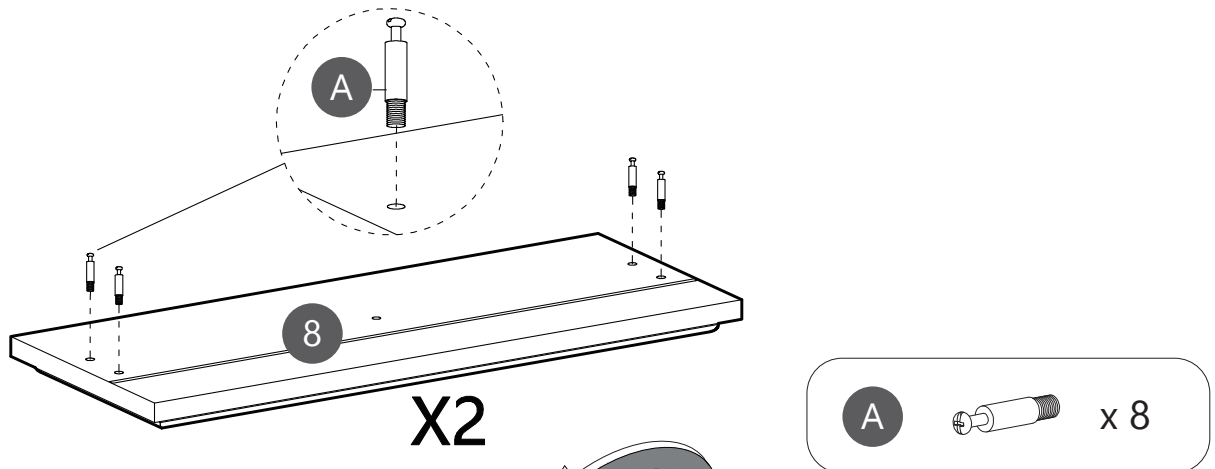

Step 13

Attach Board (8) to Board (9&10 & 12). Using Cam Lock (B) secure Board (8) to Board (9&10&12).

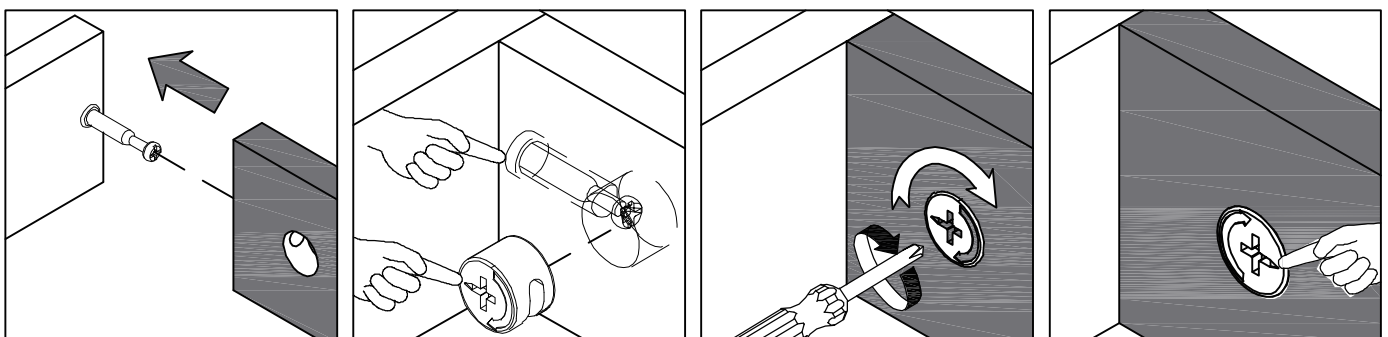
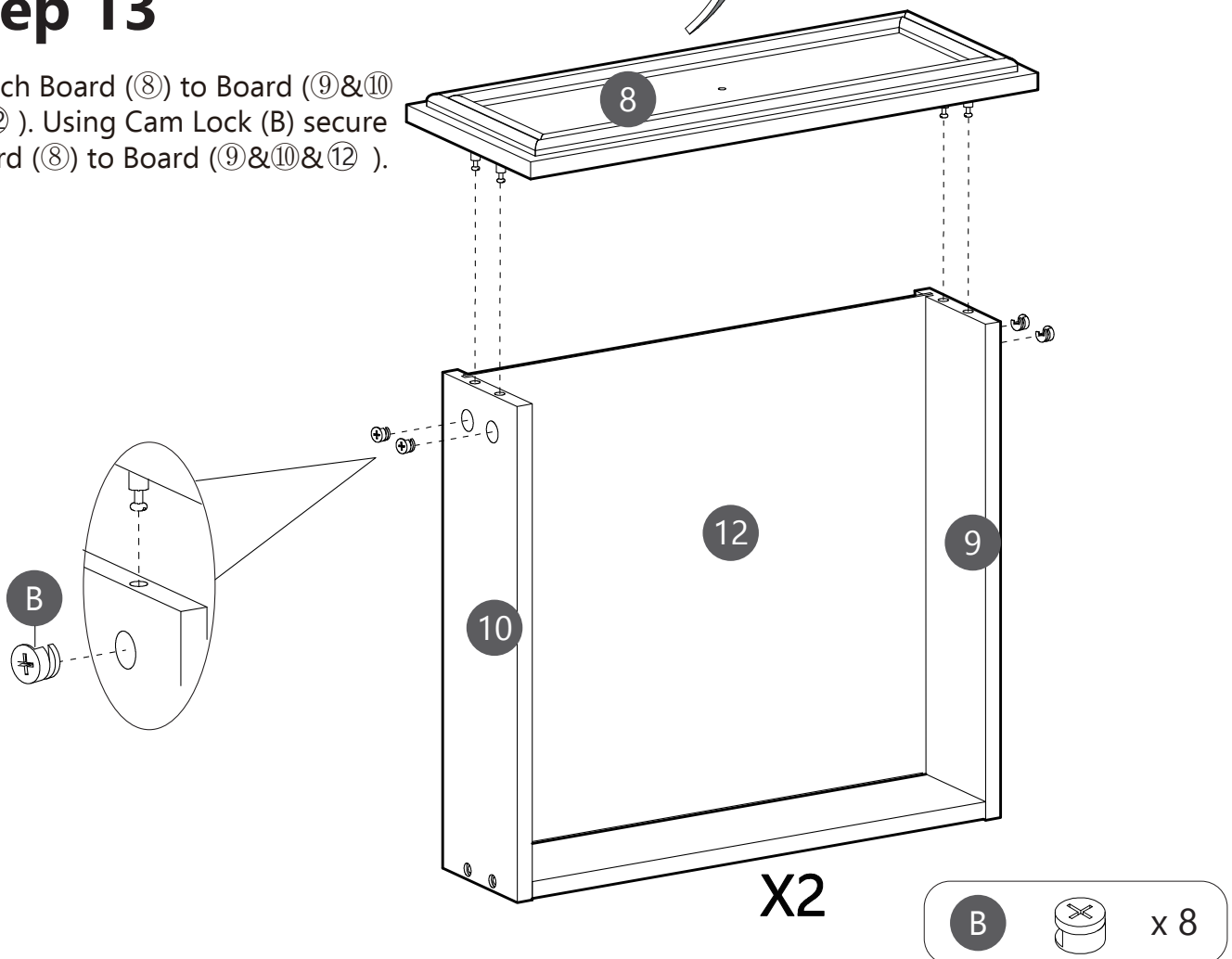

Step 14

Using Screws (I) to assemble Handle (H) to the Board (8).

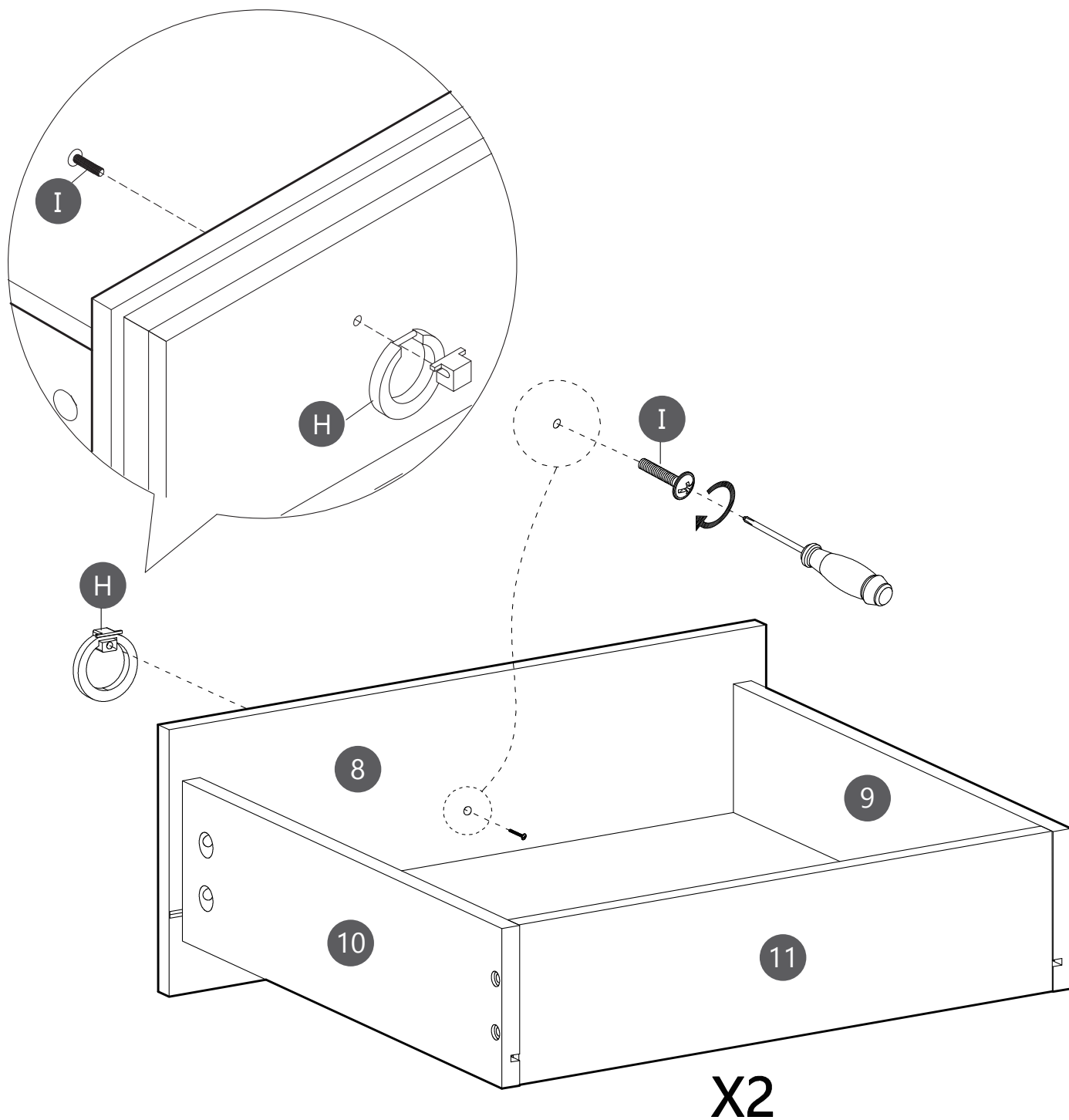

H		x 2
I		x 2

Step 15

Using Screws (F) to assemble Slide (DR) to Board (10).

Using Screws (F) to assemble Slide (DL) to Board (9).

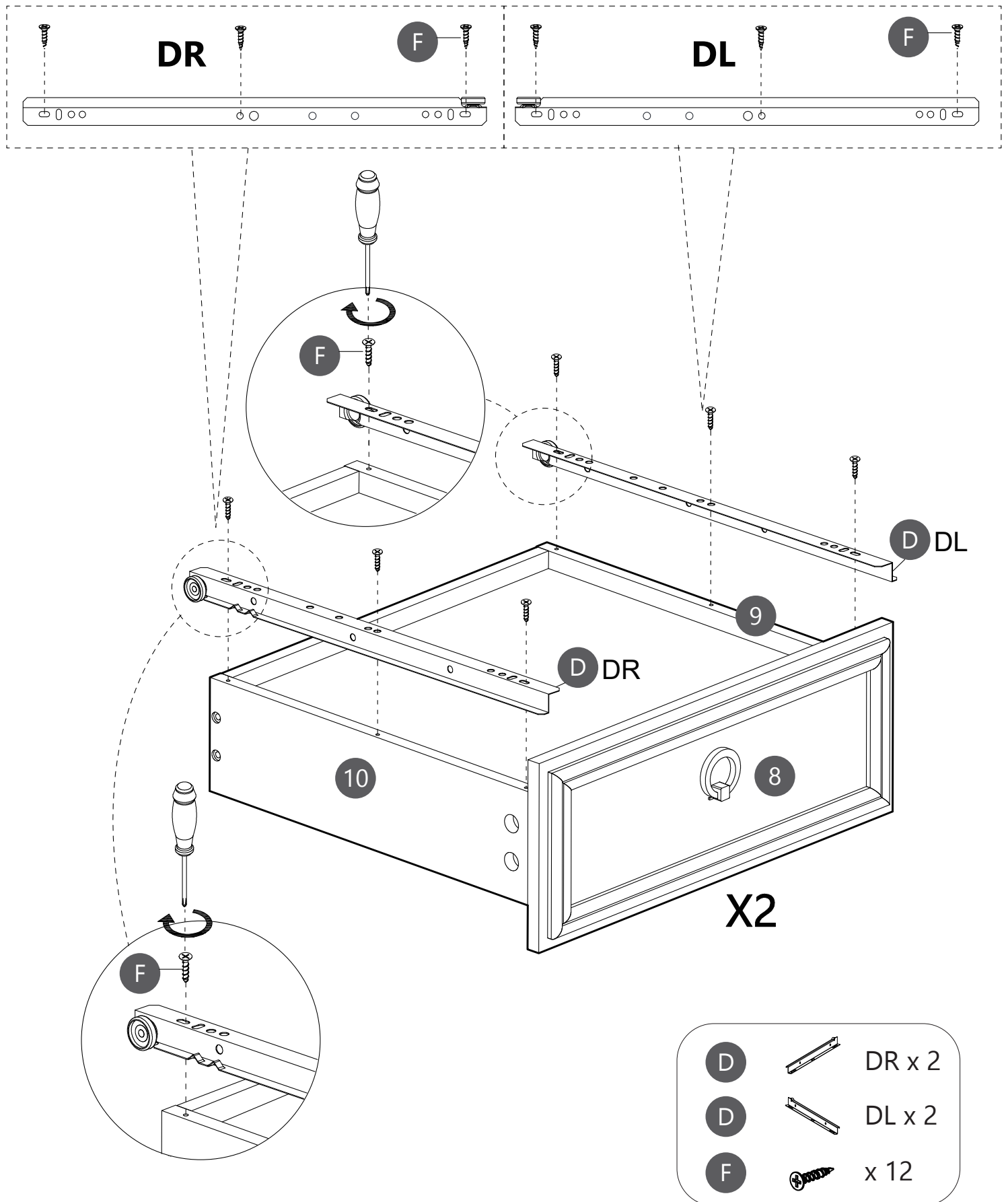

Step 16

Assembled the drawers as per diagram.

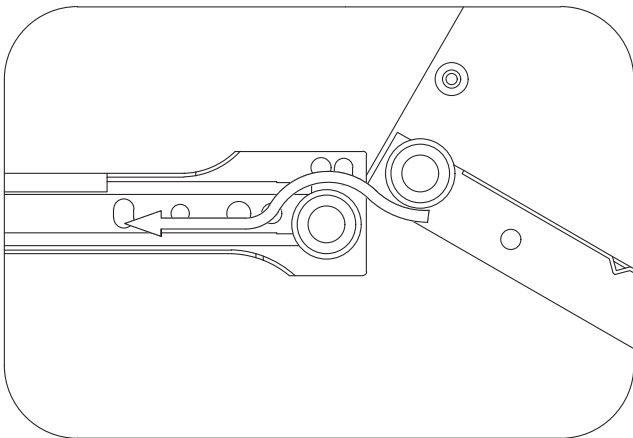
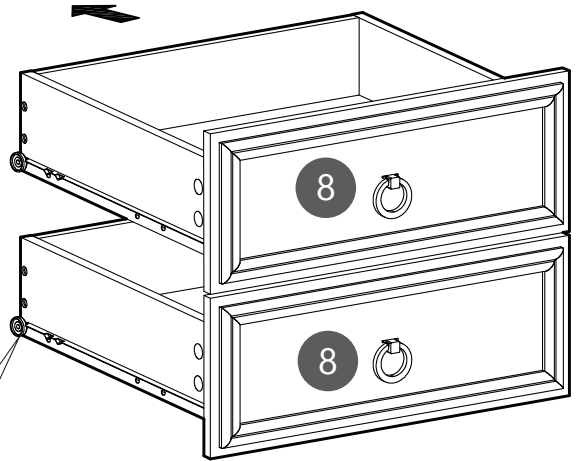
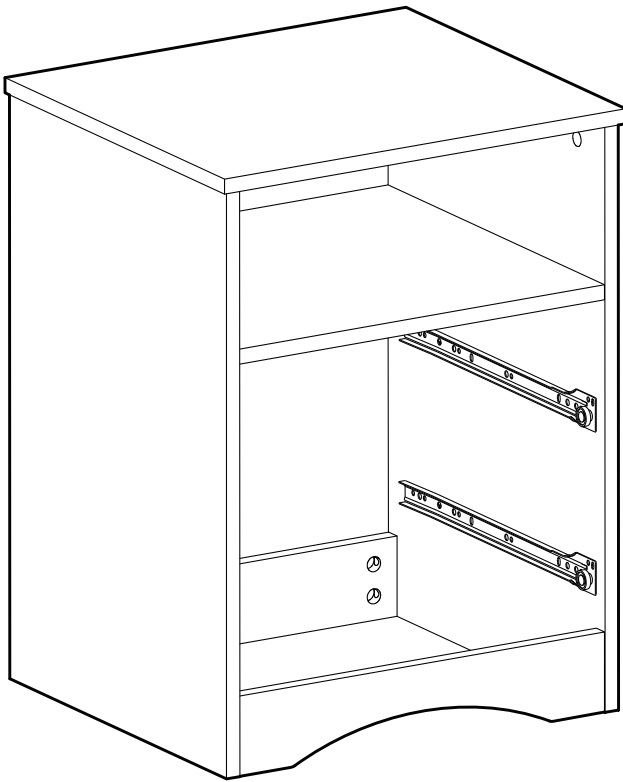

When you put the drawer, please note that the drawer wheels on top of the wheels of the slide, then check whether the drawer is smooth when pulled out. Otherwise, the drawer will not be aligned with other drawers.

Step 17

