

ASSEMBLY INSTRUCTION

INSTRUCTIONS DE MONTAGE

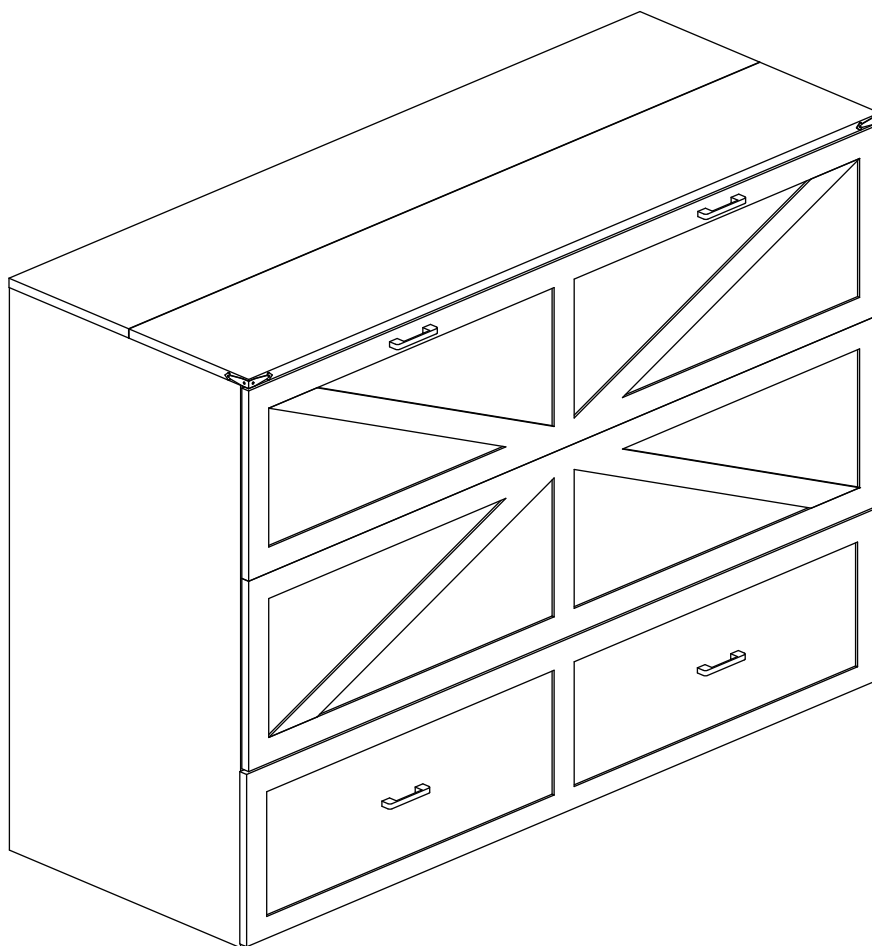

Detail view:

vue détaillée:

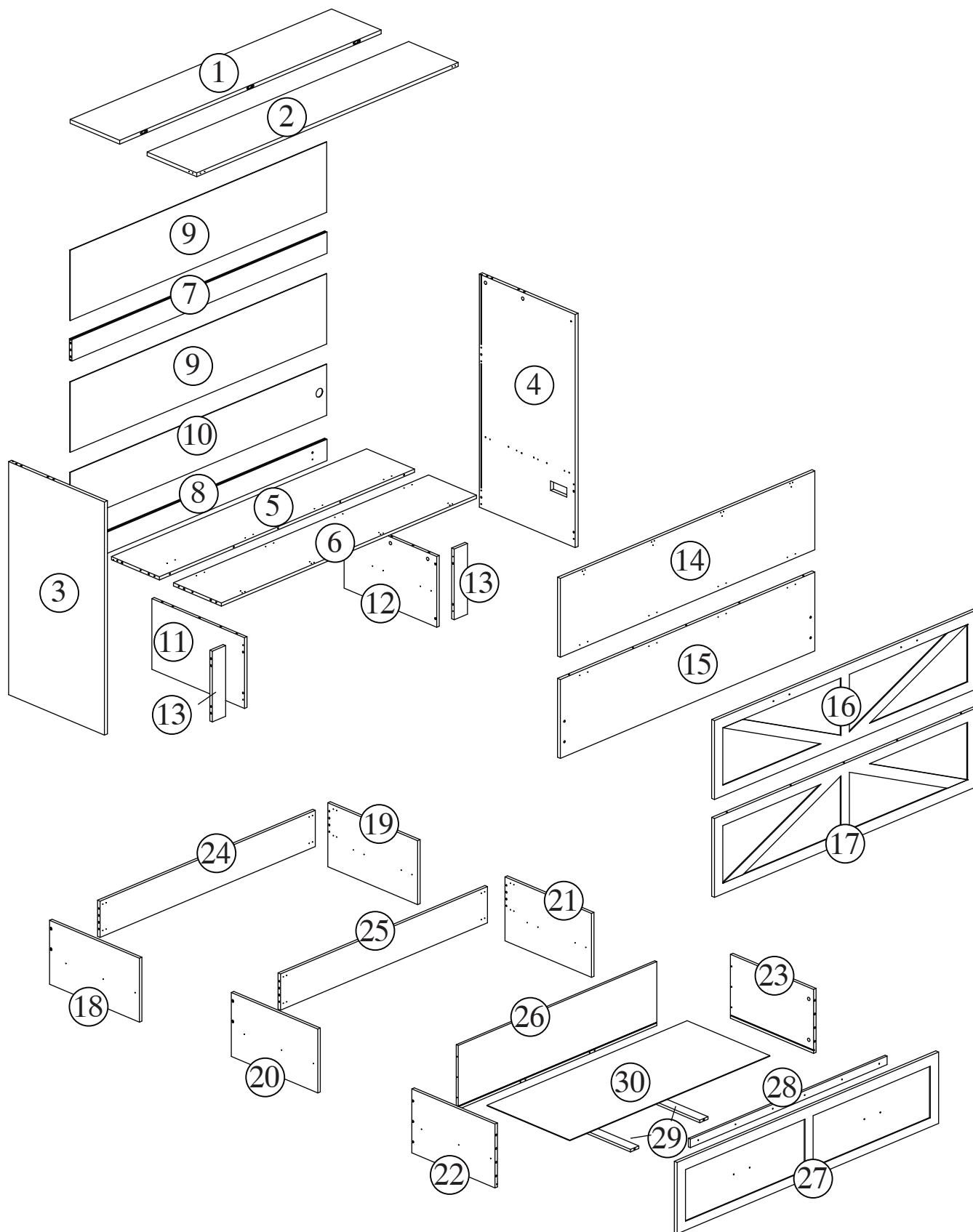

Part List(Box 1)

Liste des pièces boîte 1

① x1

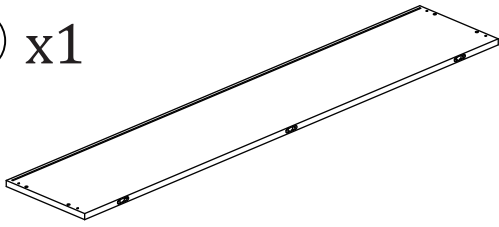

② x1

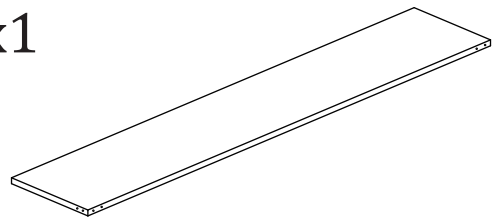

⑤ x1

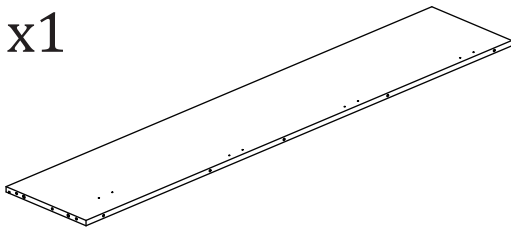

⑥ x1

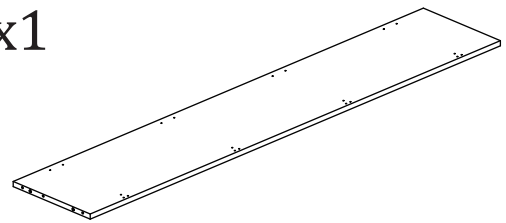

⑦ x1

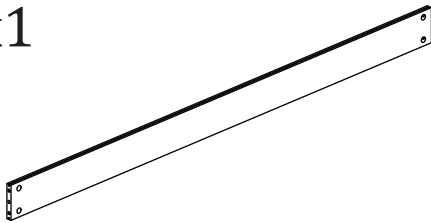

⑧ x1

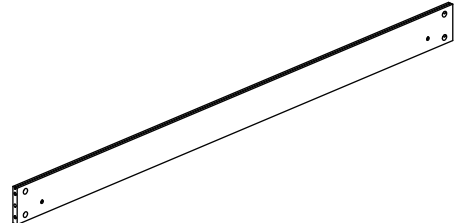

⑨ x2

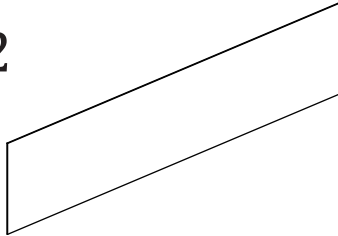

⑩ x1

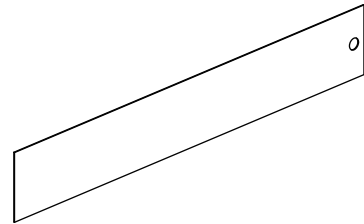

⑭ x1

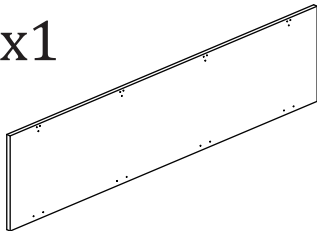

⑮ x1

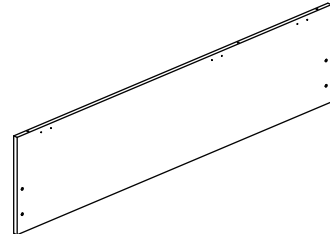

⑰ x1

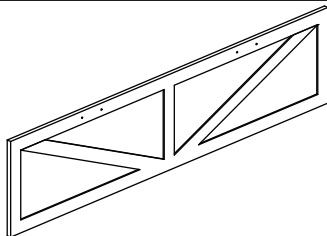

⑰ x1

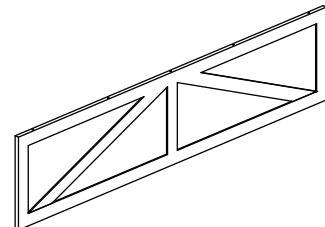

⑳ x1

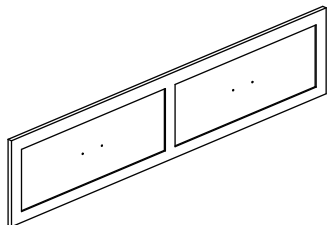

㉘ x1

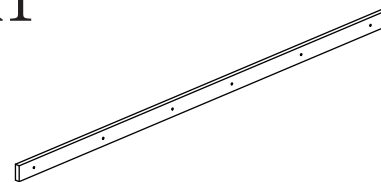

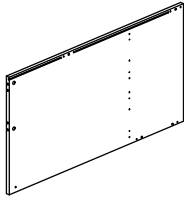
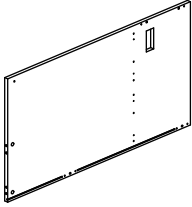
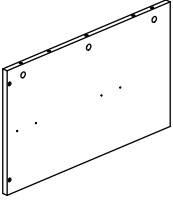
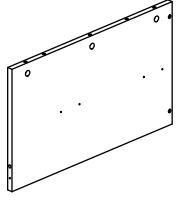
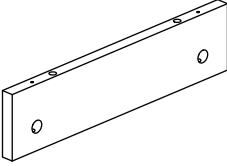
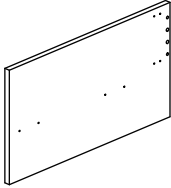
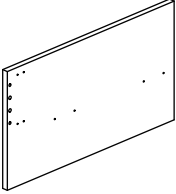
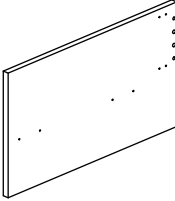
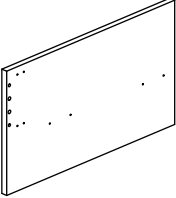
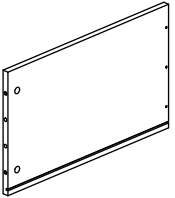
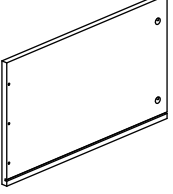
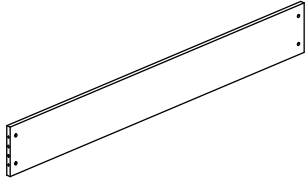
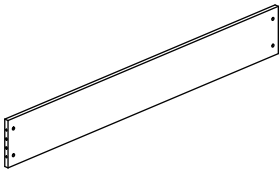
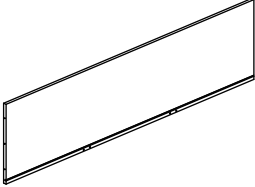
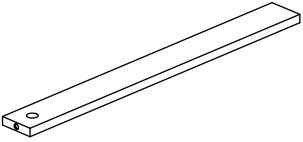
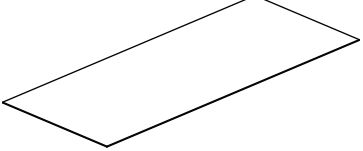

Part List & Hardware List(Box 2)

Liste des pièces & Liste du matériel boîte 2

③ x1 	④ x1 
⑪ x1 	⑫ x1 
⑬ x2 	⑱ x1 
⑲ x1 	⑳ x1 
㉑ x1 	㉒ x1 
㉓ x1 	㉔ x1 
㉕ x1 	㉖ x1 
㉙ x2 	㉚ x1 

Part List & Hardware List(Box 2)

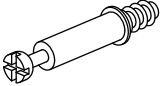
Liste des pièces & Liste du matériel boîte 2

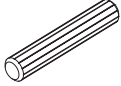
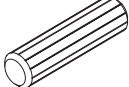
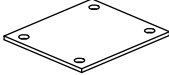
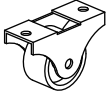
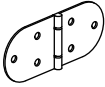
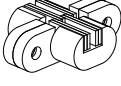
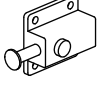
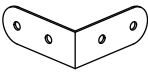
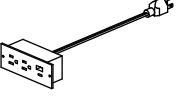
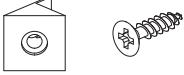
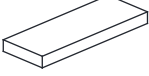
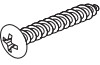



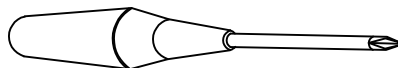





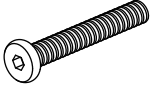

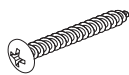
No.	OUTLOOK	DESC	QTY
(A)			36
(B)			36
(C)		Dowel Ø 6*30mm Cheville	46
(D)		Dowel Ø 8*40mm Cheville	15
(E)			12
(F)		Wheels roues	12
(G)		Hinge Charnière	8
(H)		Hinge Charnière	3
(I)		Fastener La boucle	2
(J)		Base L Base	8
(K)		Socekt Le rang	1
(L)		Back plate buckle Backplate avec boucle	14
(M)			16
(N)		Screws Ø 4*20mm Des vis	6

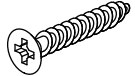
ASSEMBLY TOOLS REQUIRED (NOT INCLUDED)/OUTILS D'ASSEMBLAGE REQUIS (NON INCLUS)

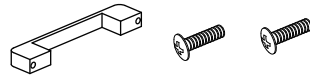
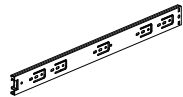

Part List & Hardware List(Box 2)

Liste des pièces & Liste du matériel boîte 2

No.	OUTLOOK	DESC	QTY
○		Bolts Ø 6*50mm Boulons	8
○			8
○		Screws Ø 4*40mm Des vis	16
○		Screws Ø 4*18mm Des vis	24
○		Screws Ø 3.5*30mm Des vis	12
○			2
○		Screws Ø 4*14mm Des vis	178
○		Screws Ø 3*14mm Des vis	2
○		Allebn key clé Allen	1
○		Handle De montures	6
○		Slideway Le patin	6
○		Anti-reverse tape Protection contre le rebobinage	2
○		Corner pad Tapis de la corne de l'afrique	4
○			4

ASSEMBLY TOOLS REQUIRED (NOT INCLUDED)/OUTILS D'ASSEMBLAGE REQUIS (NON INCLUS)

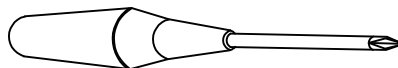

STEP 1:

Étape

Please open the slide by pressing the buckle.
Veuillez ouvrir la glissière en appuyant sur la boucle.

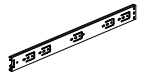
(Y)		06
-----	--	----

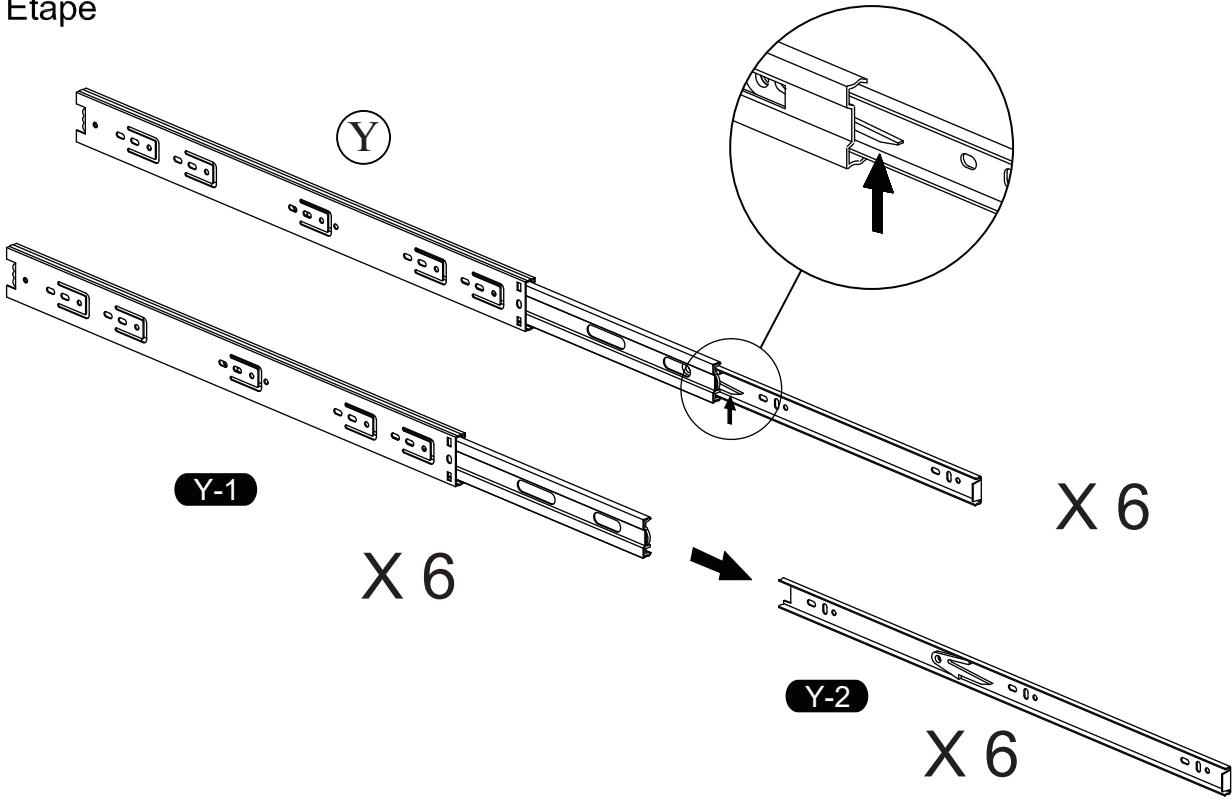

STEP 2:

Étape

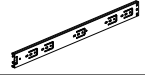
(U)		4*14mm	08
(Y)			02

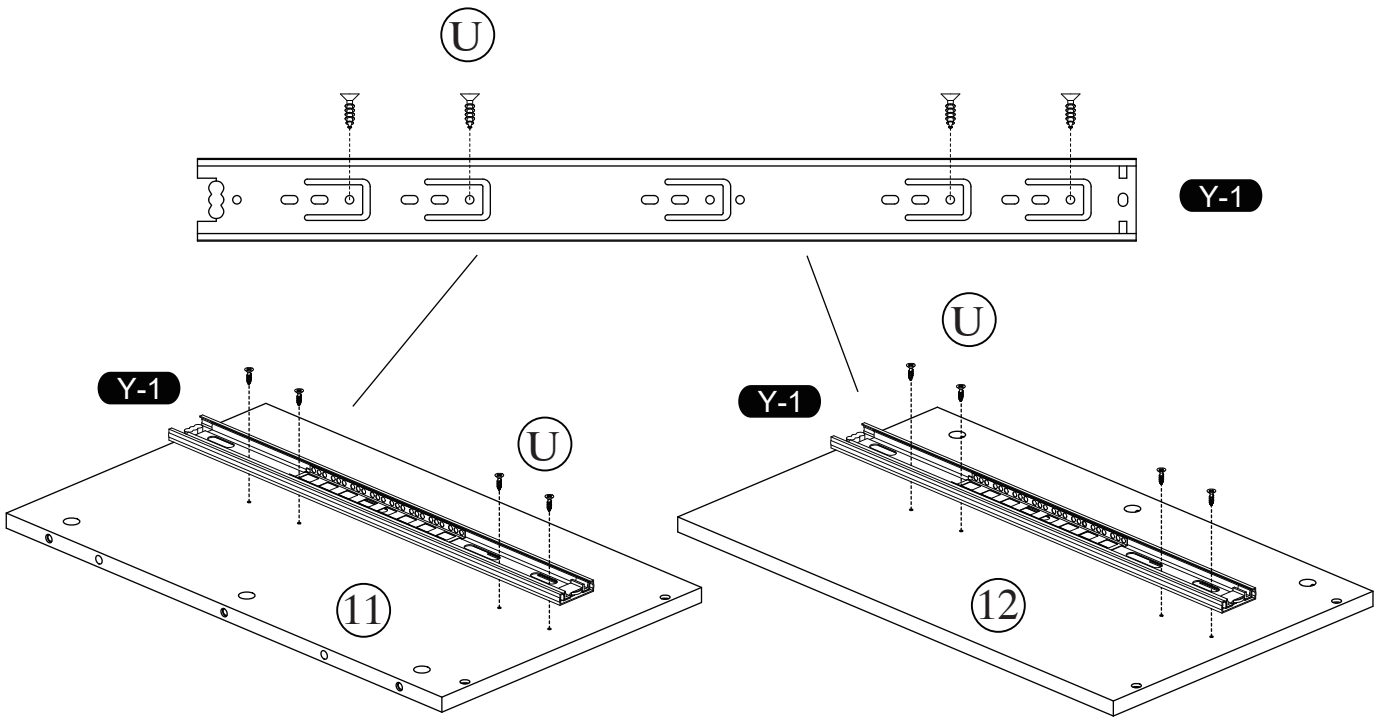

STEP 3:

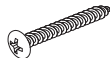

Étape

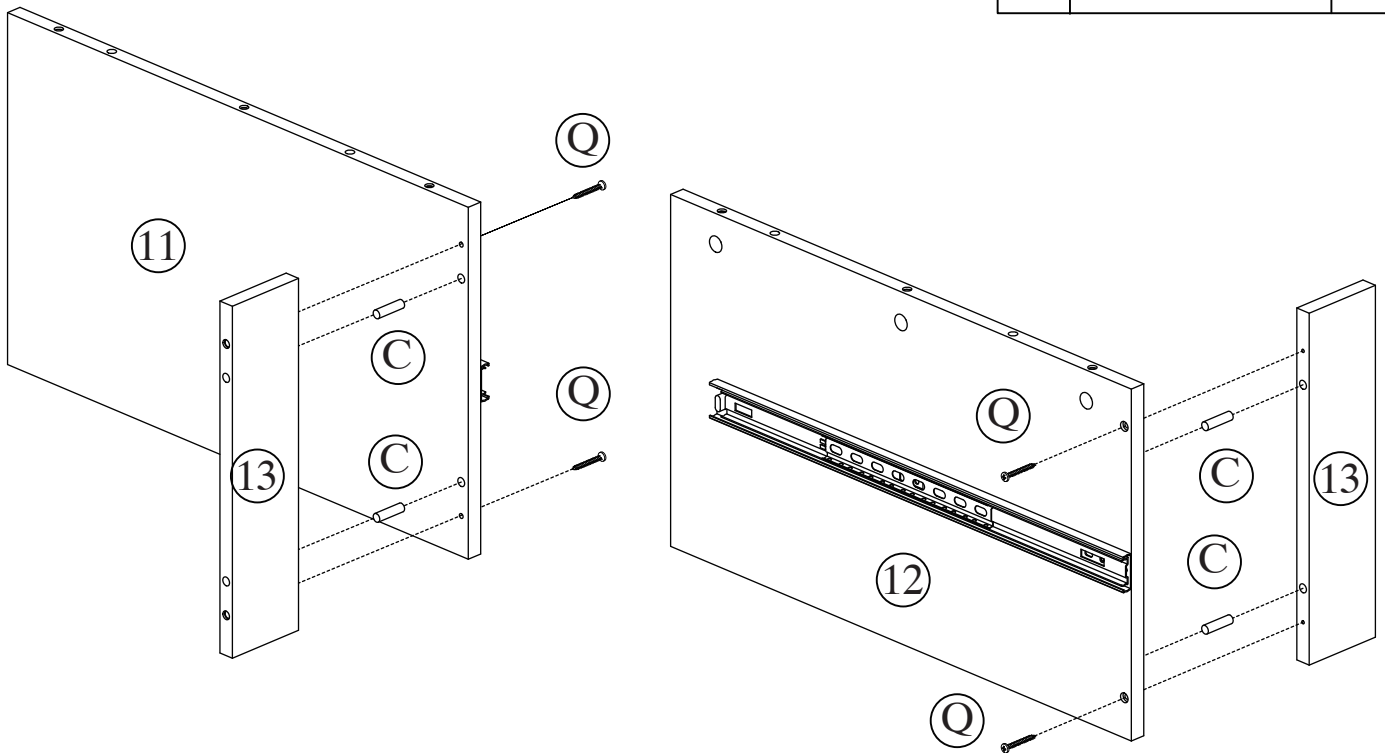
(C)		6*30mm	04
(Q)		4*40mm	04



STEP 4:

Étape

(D)		8*40mm	05
(E)			04
(U)		4*14mm	16

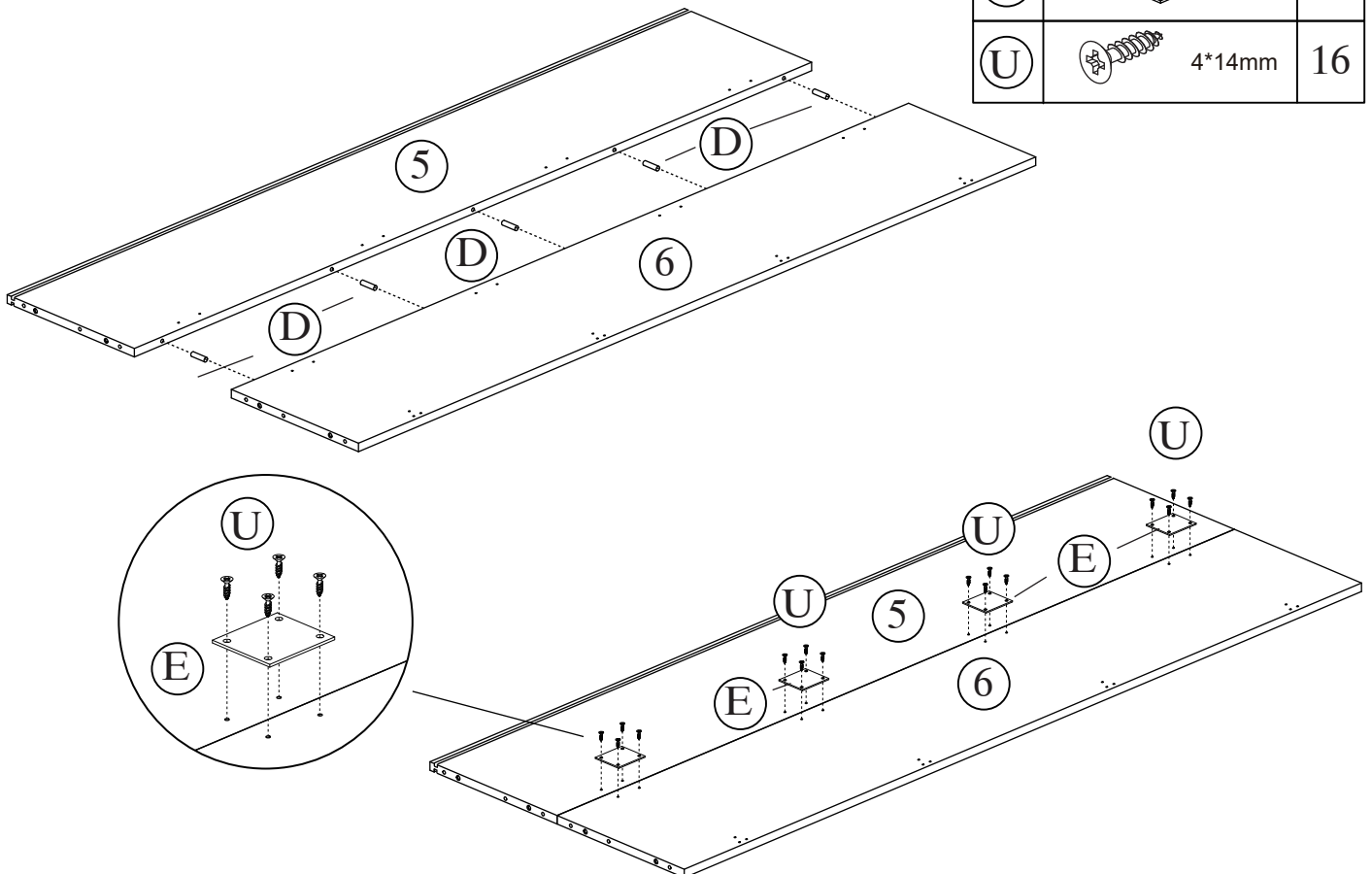

STEP 5:

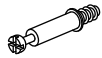

Étape

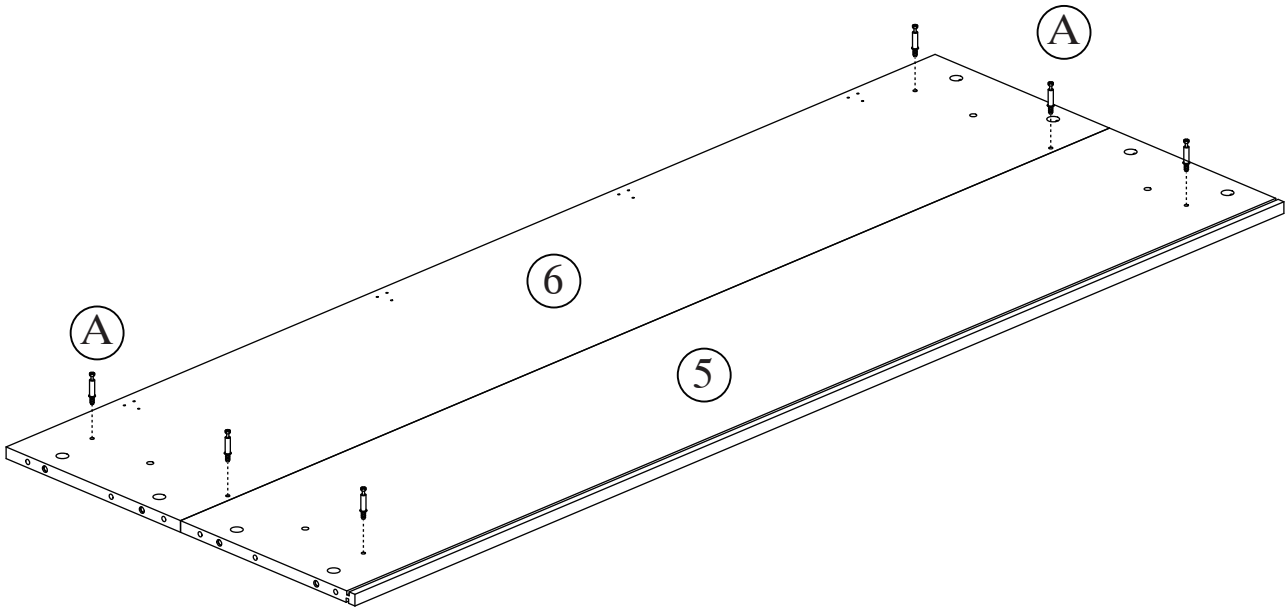
(A)		06
-----	--	----



STEP 6:

Étape

(B)		06
(C)	 6*30mm	04

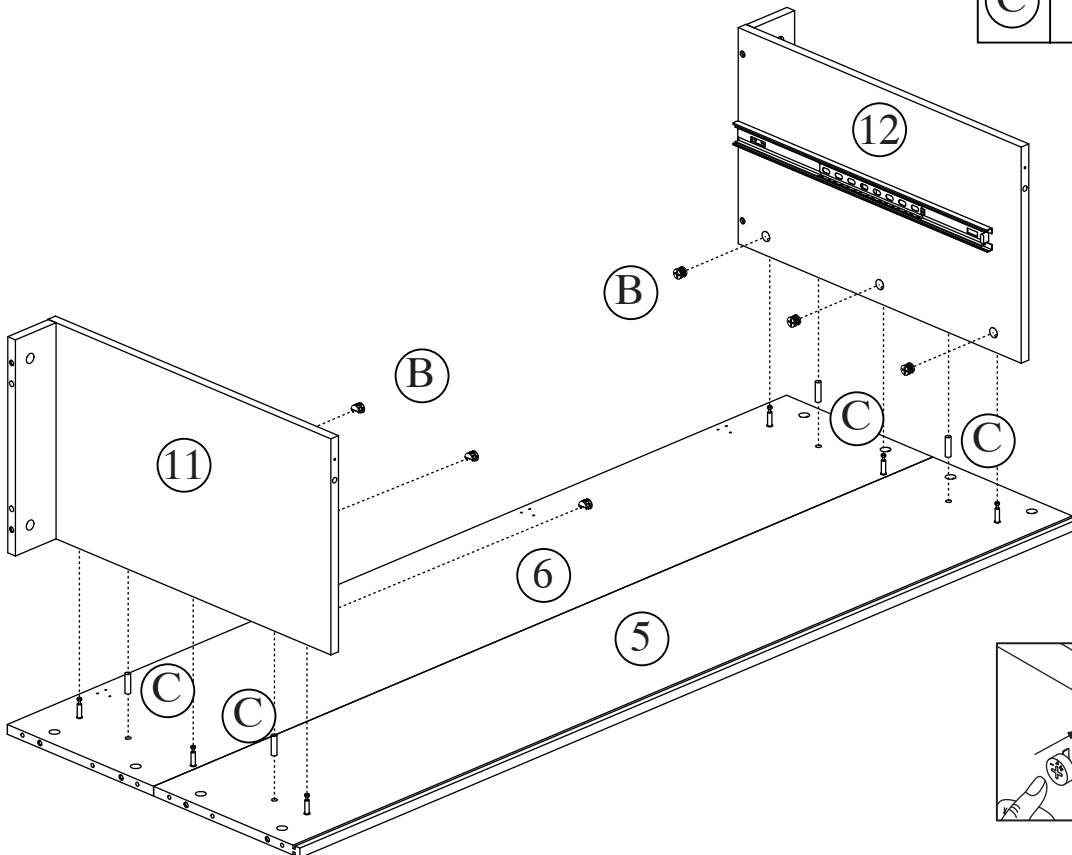

STEP 7:

Étape

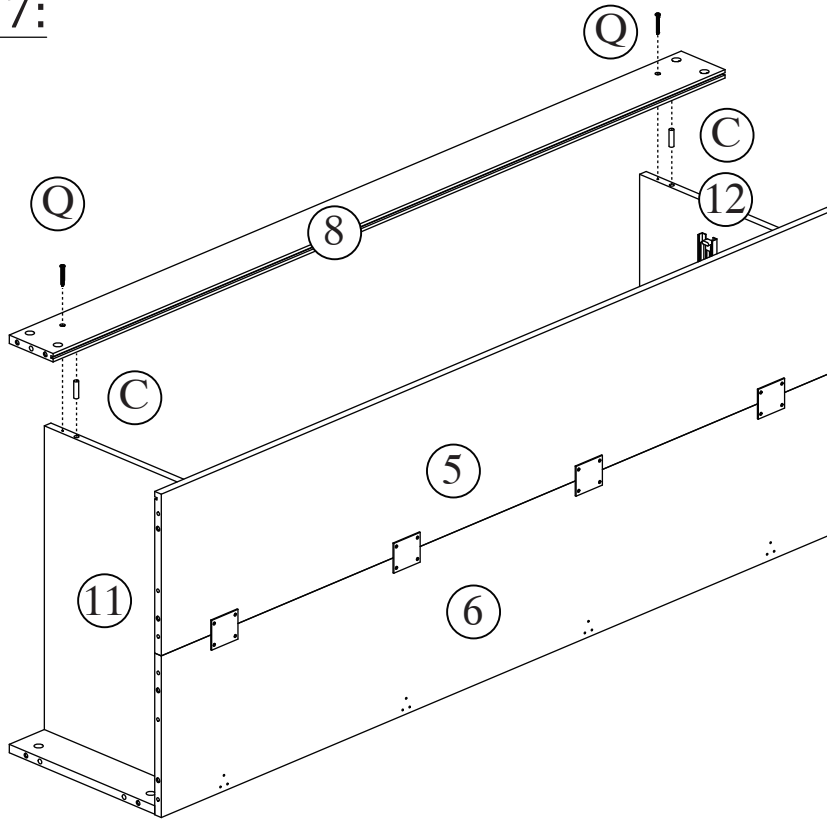

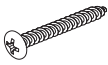
(C)		6*30mm	02
(Q)		4*40mm	02

STEP 8:

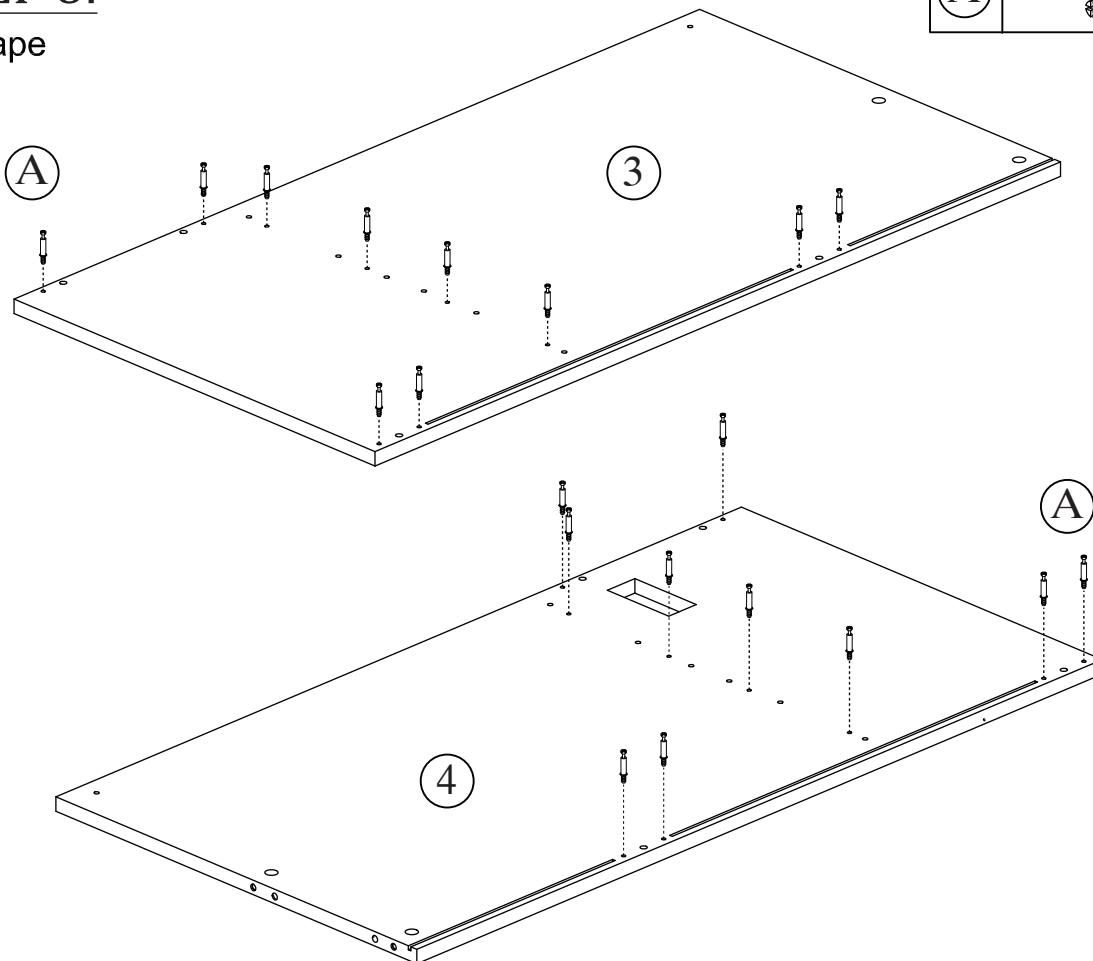

Étape

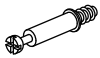

(A)			20
-----	---	--	----

STEP 9:

Étape

(B)		08
(C)	 6*30mm	09

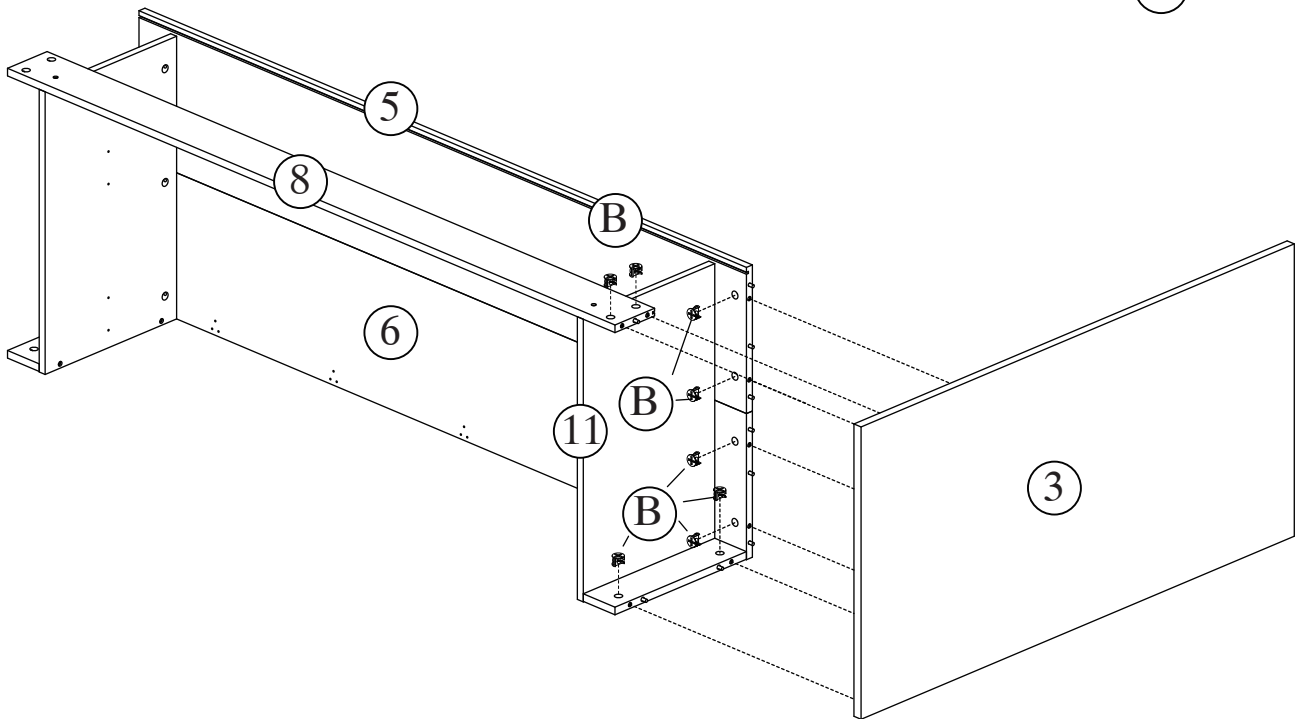
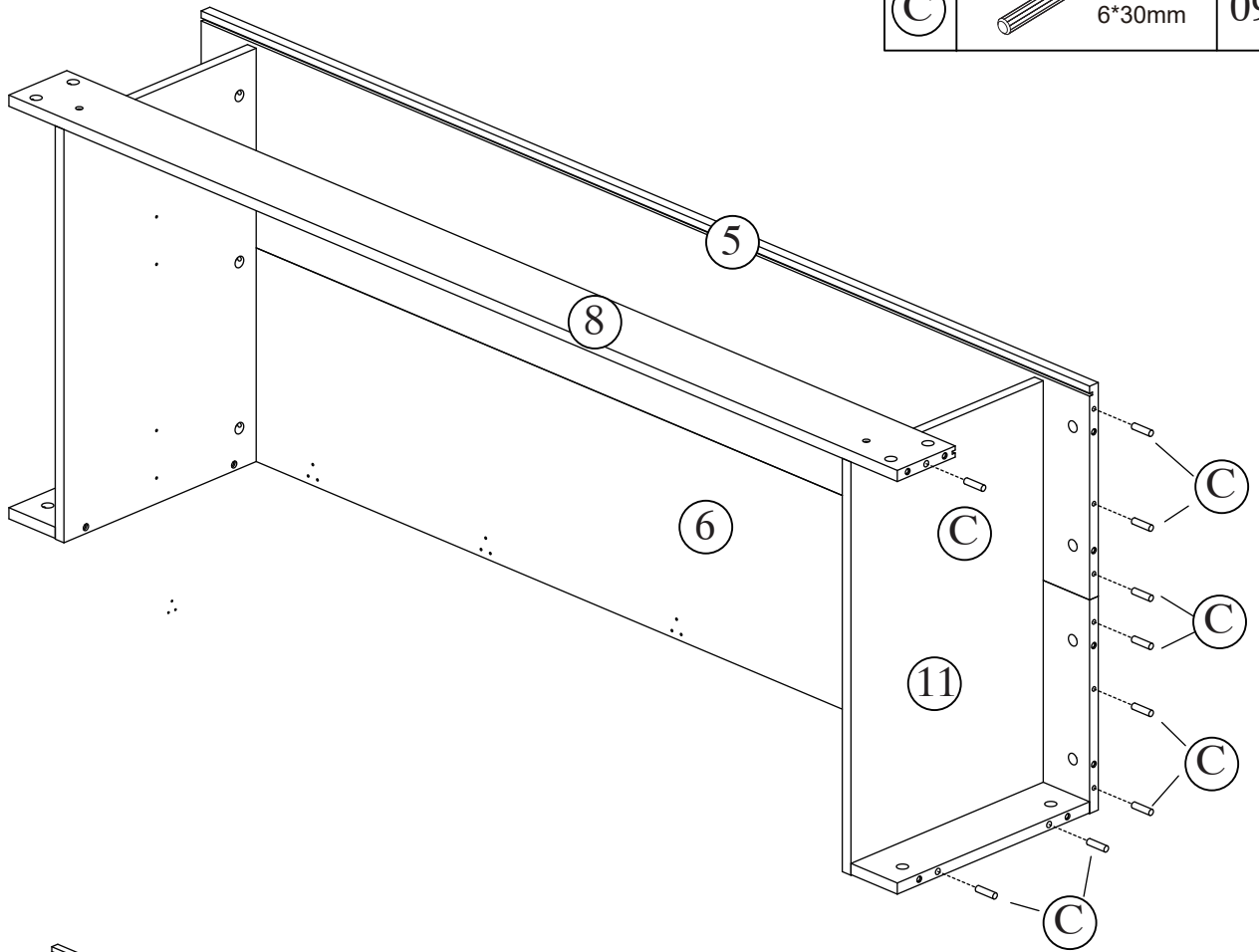

STEP 10:

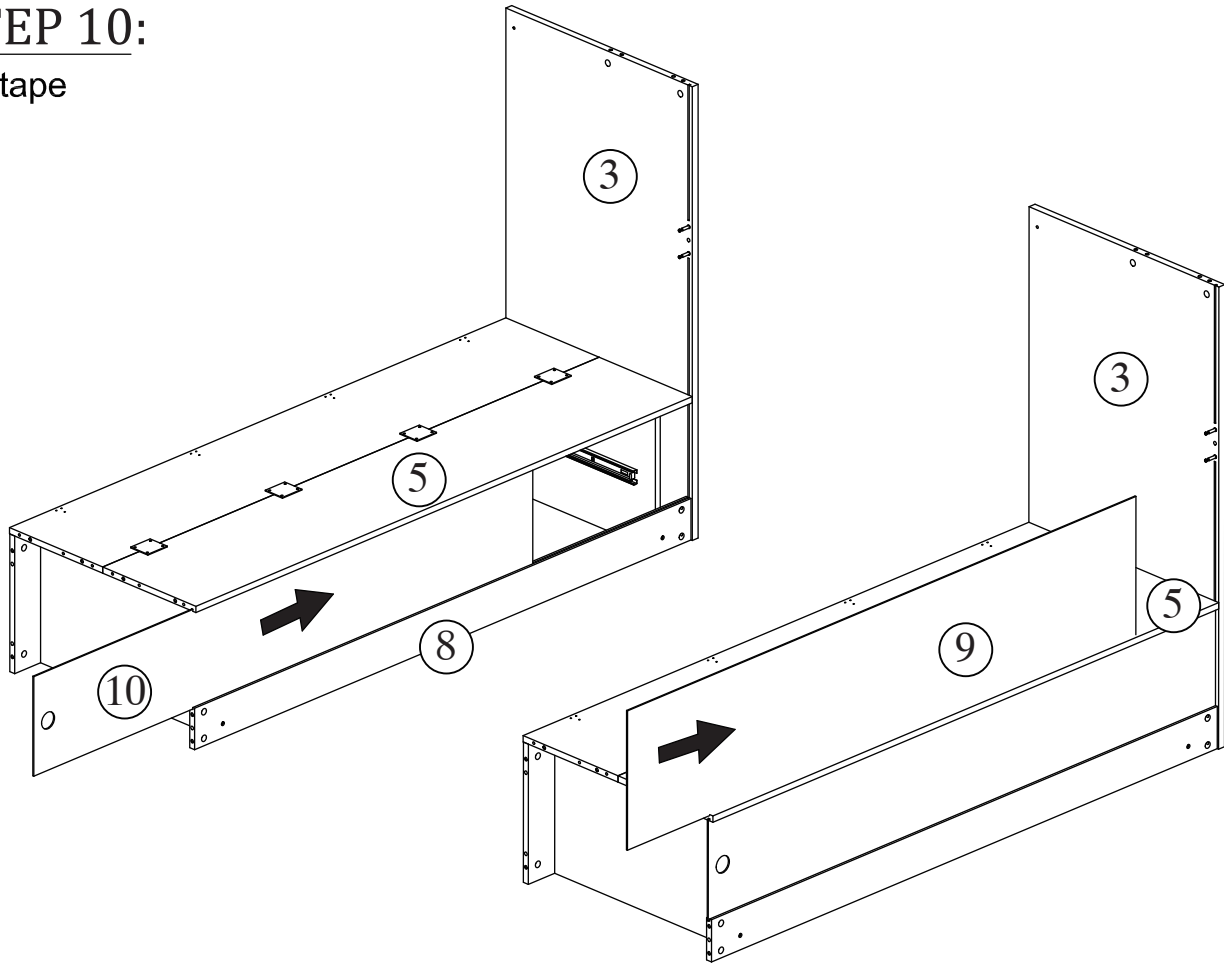

Étape

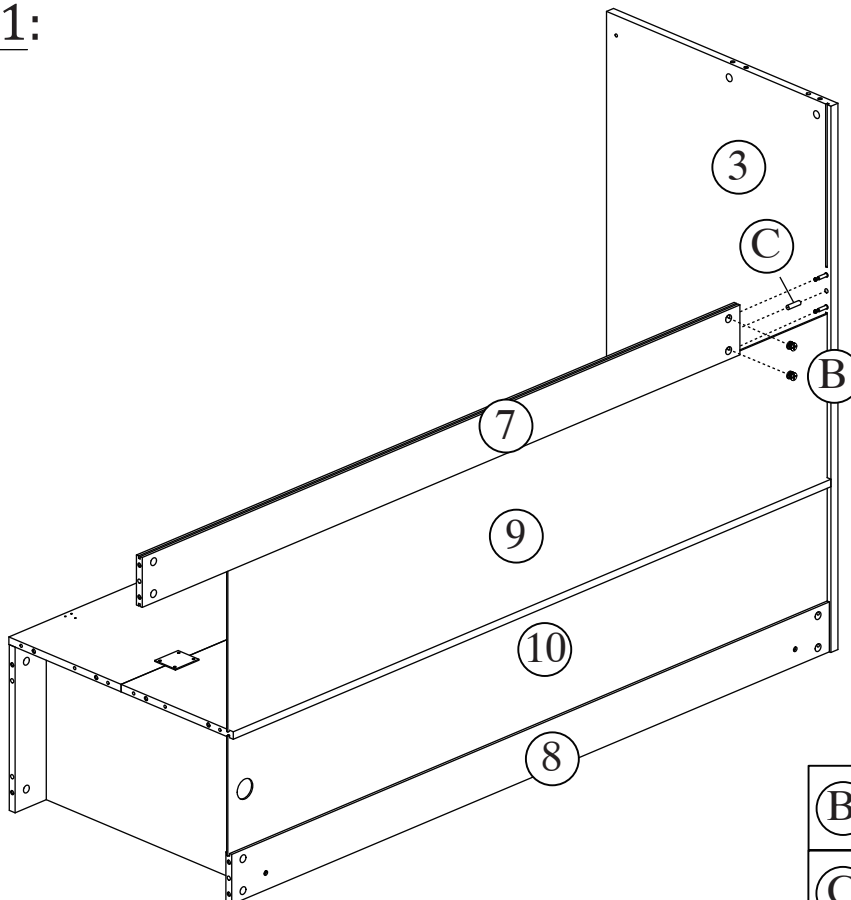

STEP 11:

Étape



(B)		02
(C)	 6*30mm	01

STEP 12:

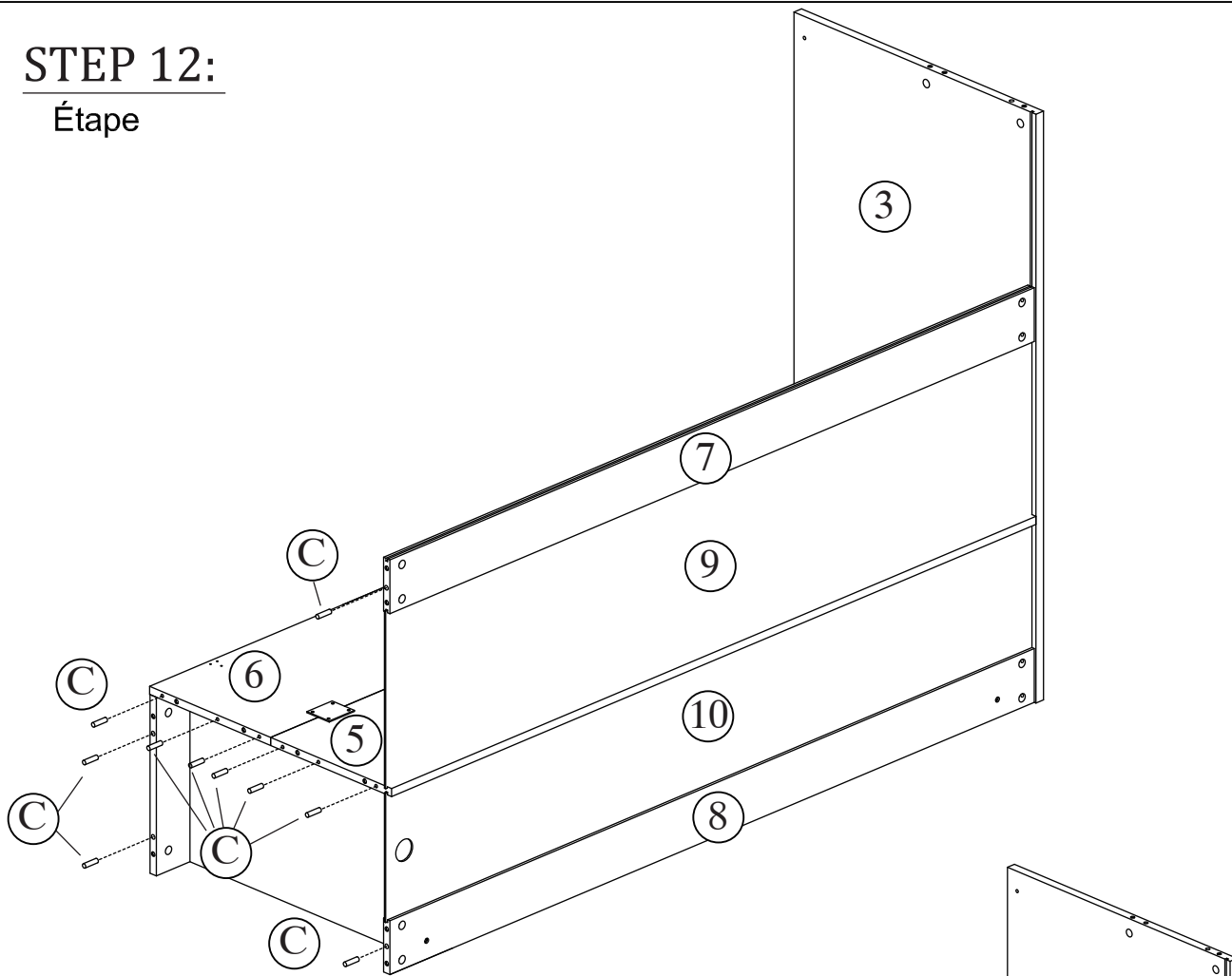

Étape

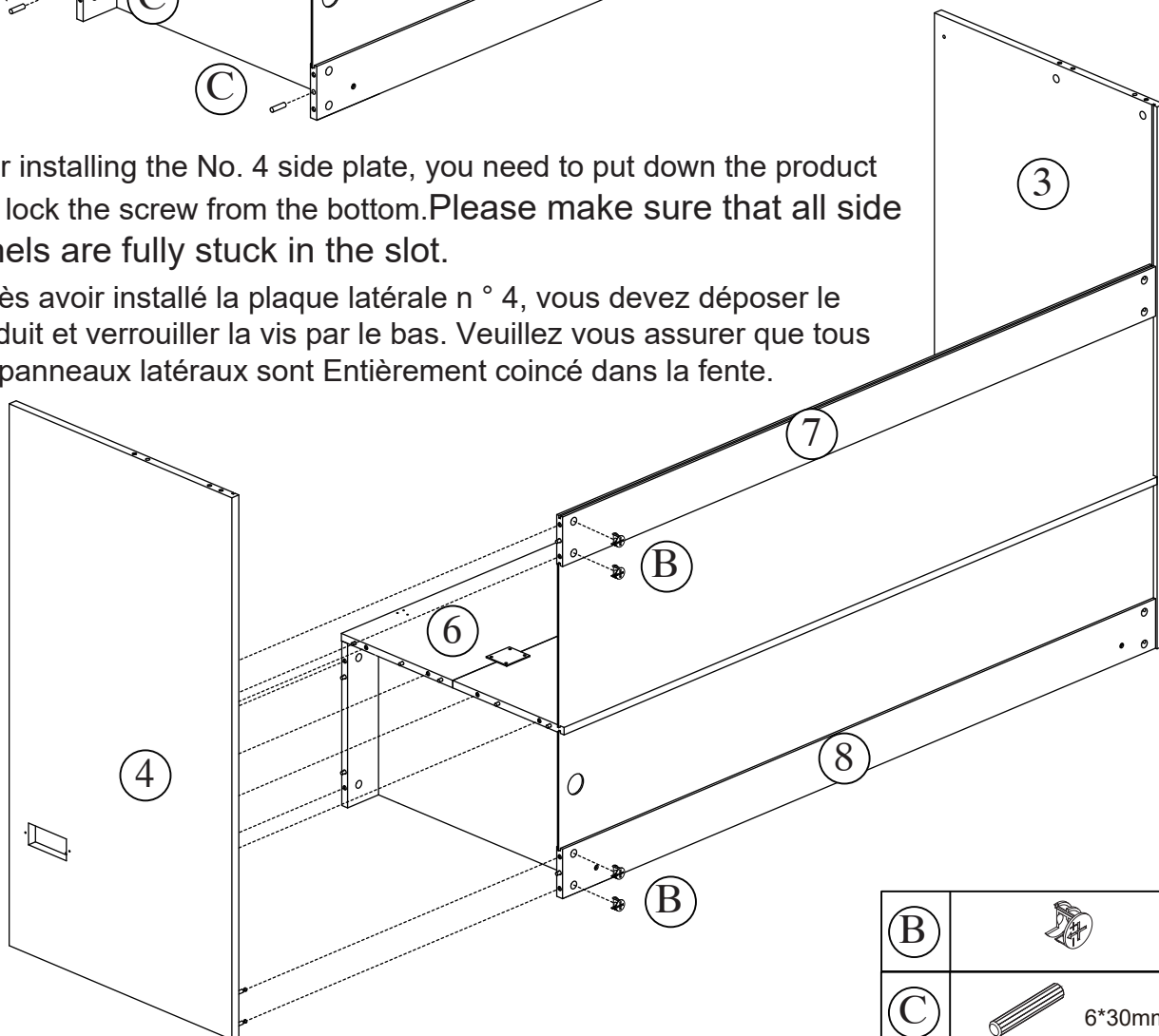

After installing the No. 4 side plate, you need to put down the product and lock the screw from the bottom. Please make sure that all side panels are fully stuck in the slot.

Après avoir installé la plaque latérale n ° 4, vous devez déposer le produit et verrouiller la vis par le bas. Veuillez vous assurer que tous les panneaux latéraux sont entièrement coincé dans la fente.





(B)		04
(C)	 6*30mm	10

STEP 13:

Étape

After installing the No. 4 side plate, you need to put down the product and lock the screw from the bottom.

Après avoir installé la plaque latérale n° 4, vous devez déposer le produit et verrouiller la vis par le bas.

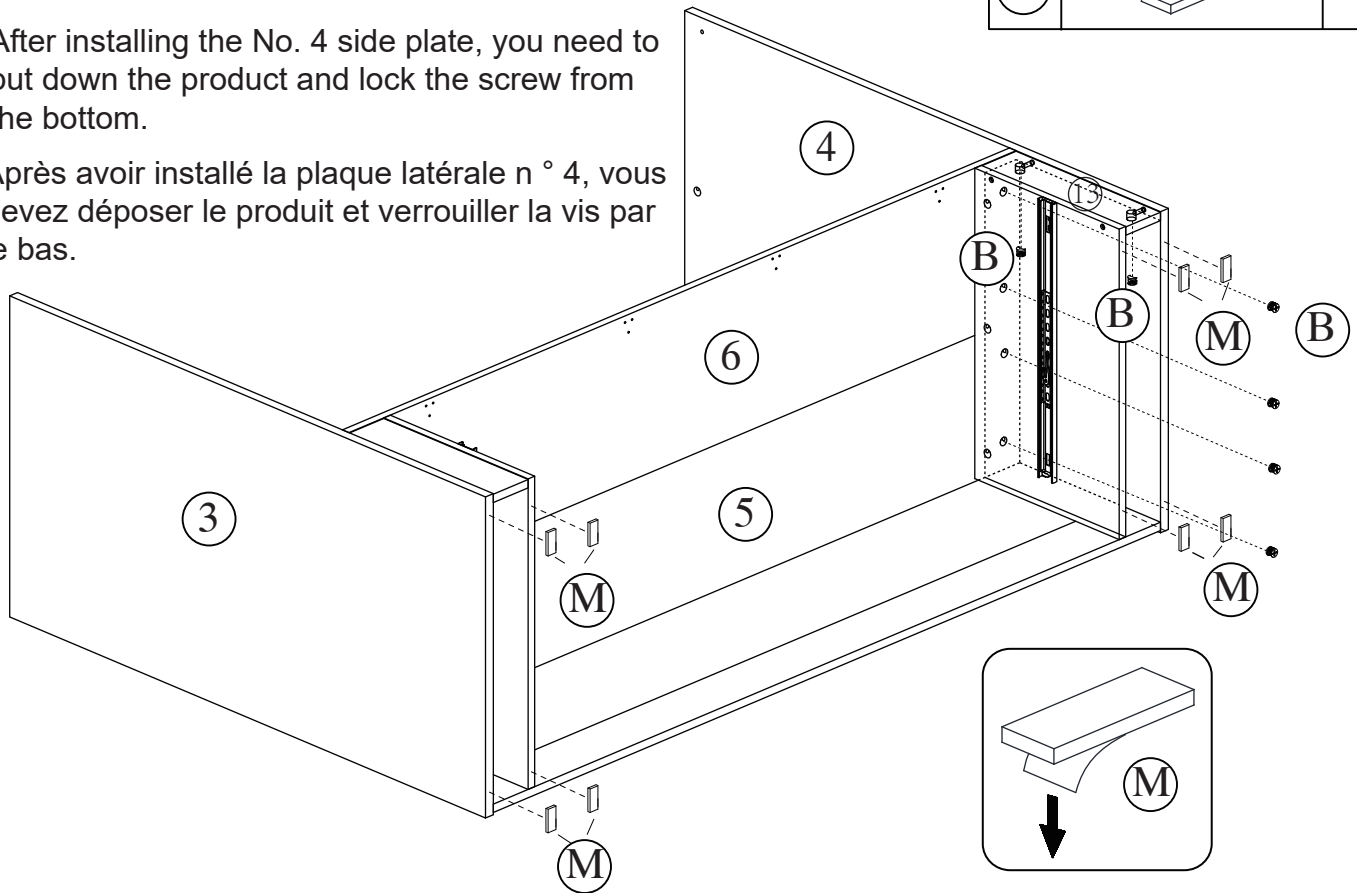

(B)		06
(M)		08

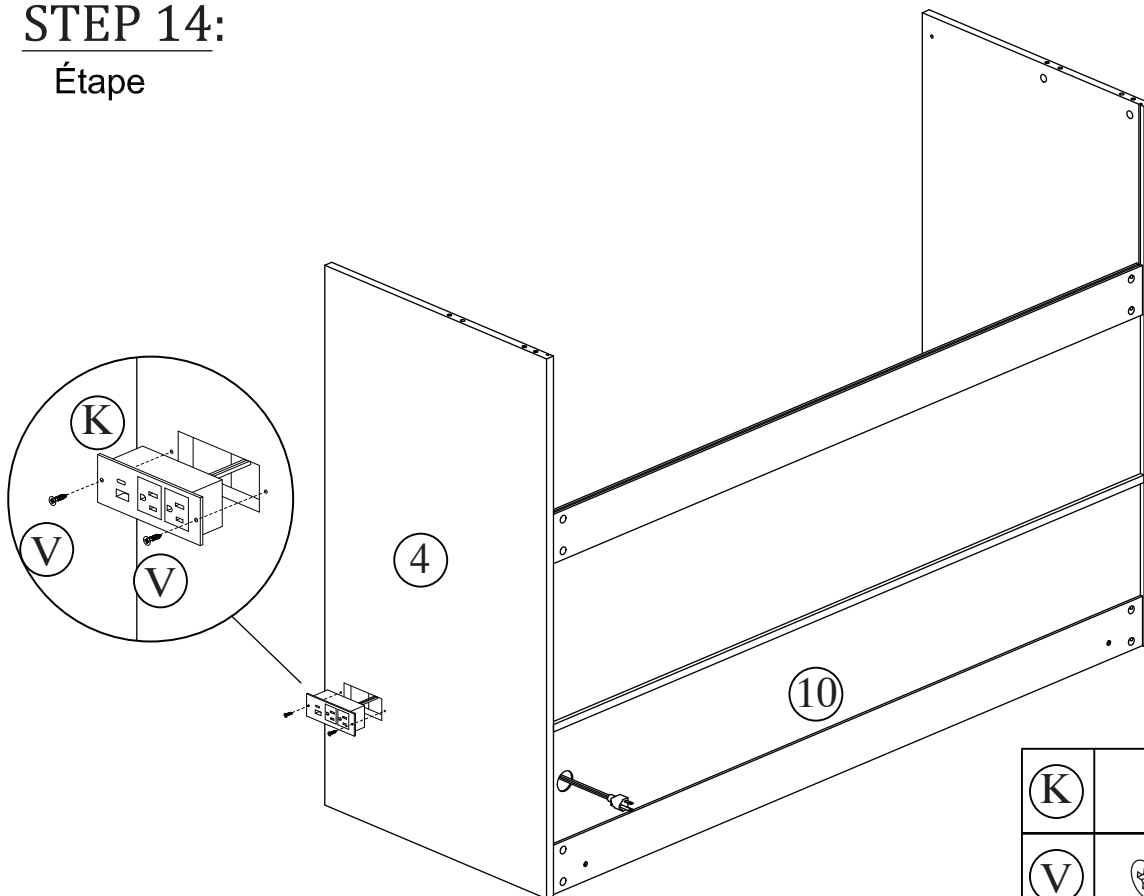

STEP 14:

Étape



(K)		01
(V)	 3*14mm	02

STEP 15:

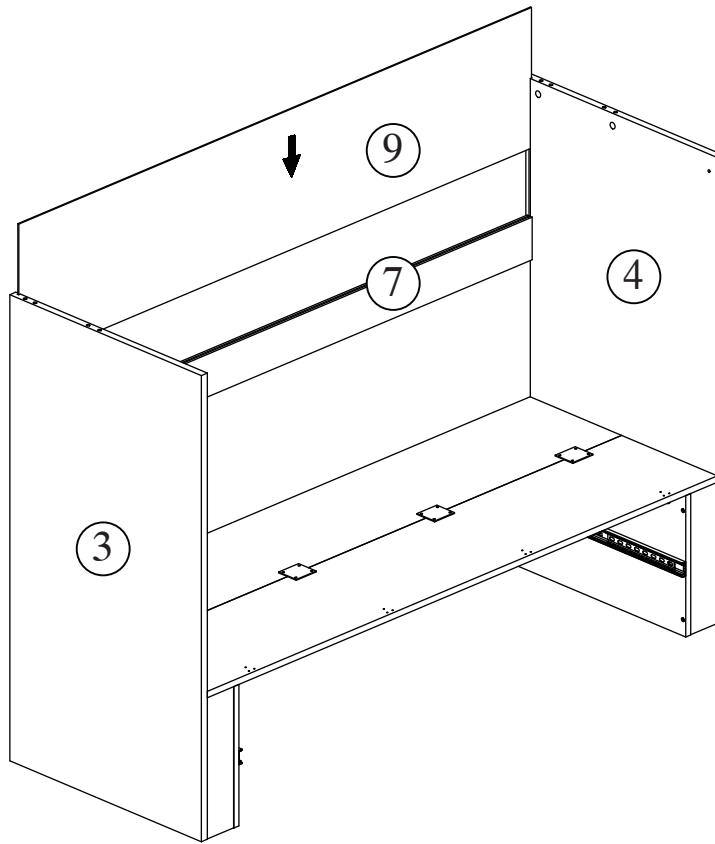

Étape

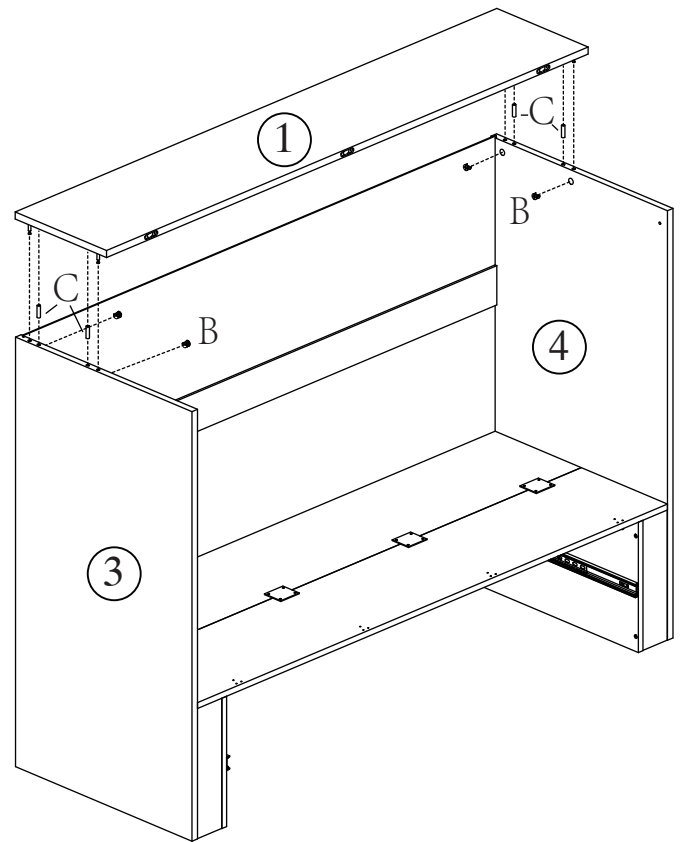
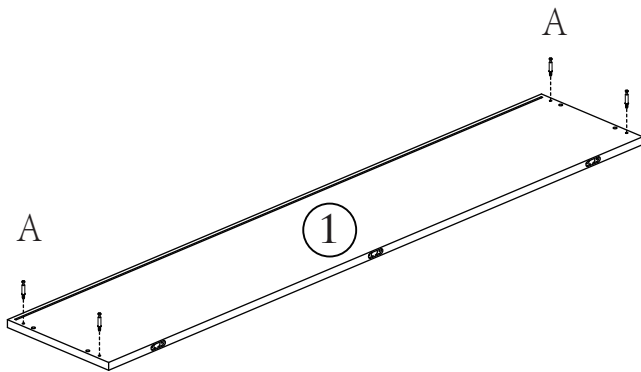

STEP 16:

Étape



(A)		04
(B)		04
(C)	 6*30mm	04

STEP 17:

Étape

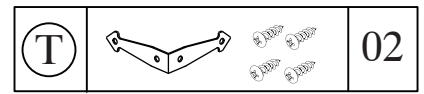
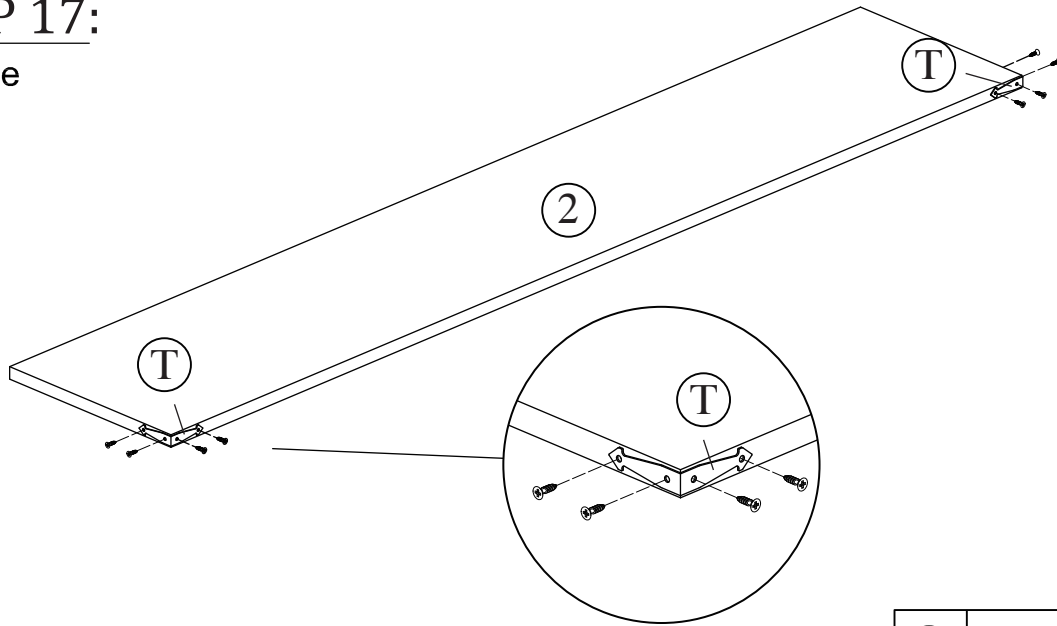

STEP 18:

Étape

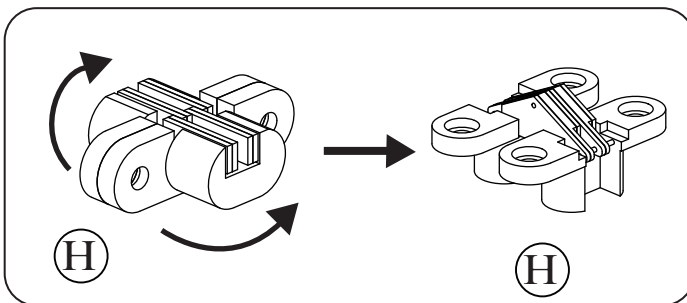
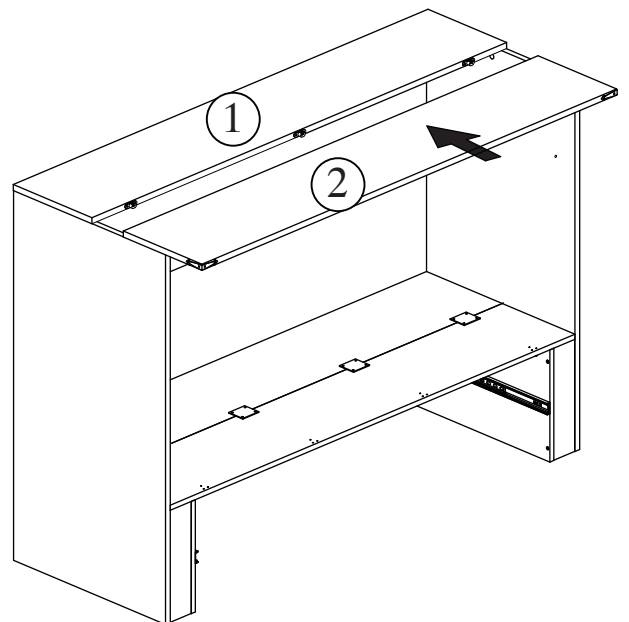
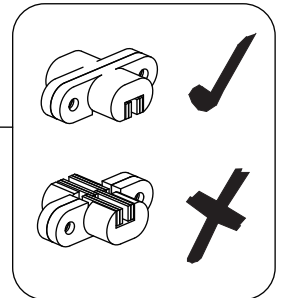
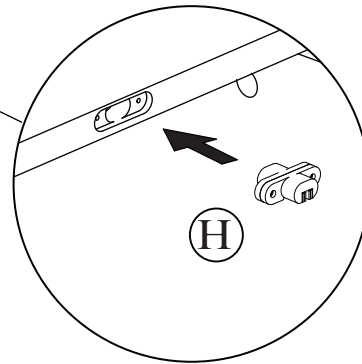
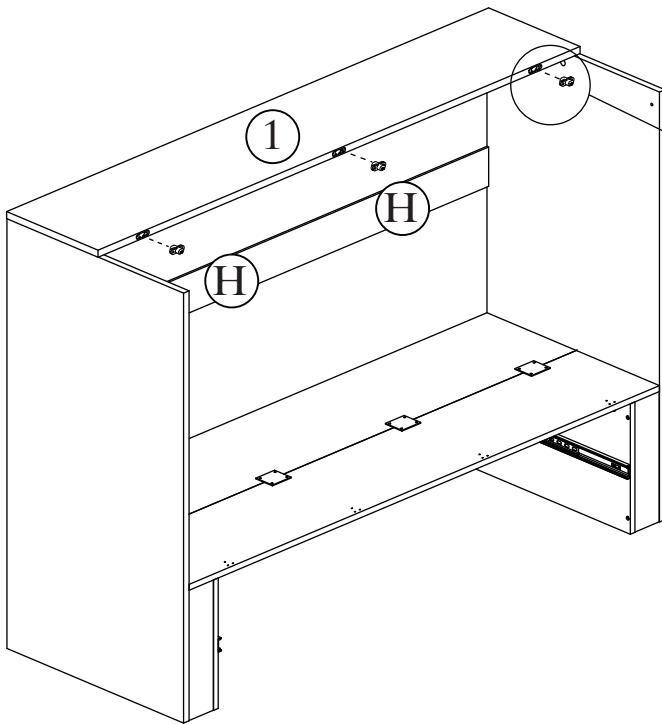
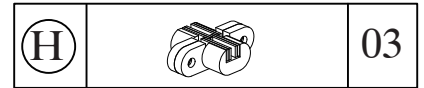

STEP 19:

Étape

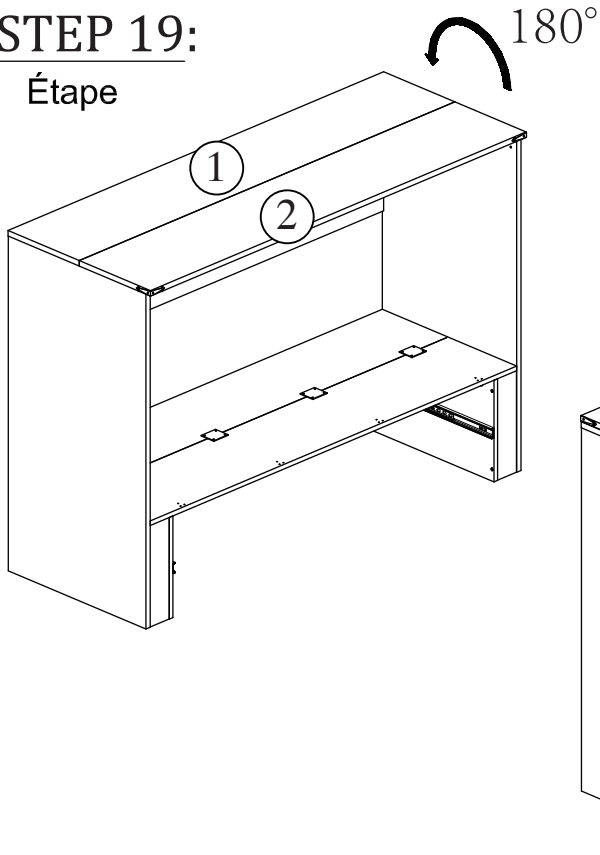



(S)		3.5*30mm	12
-----	---	----------	----

STEP 20:

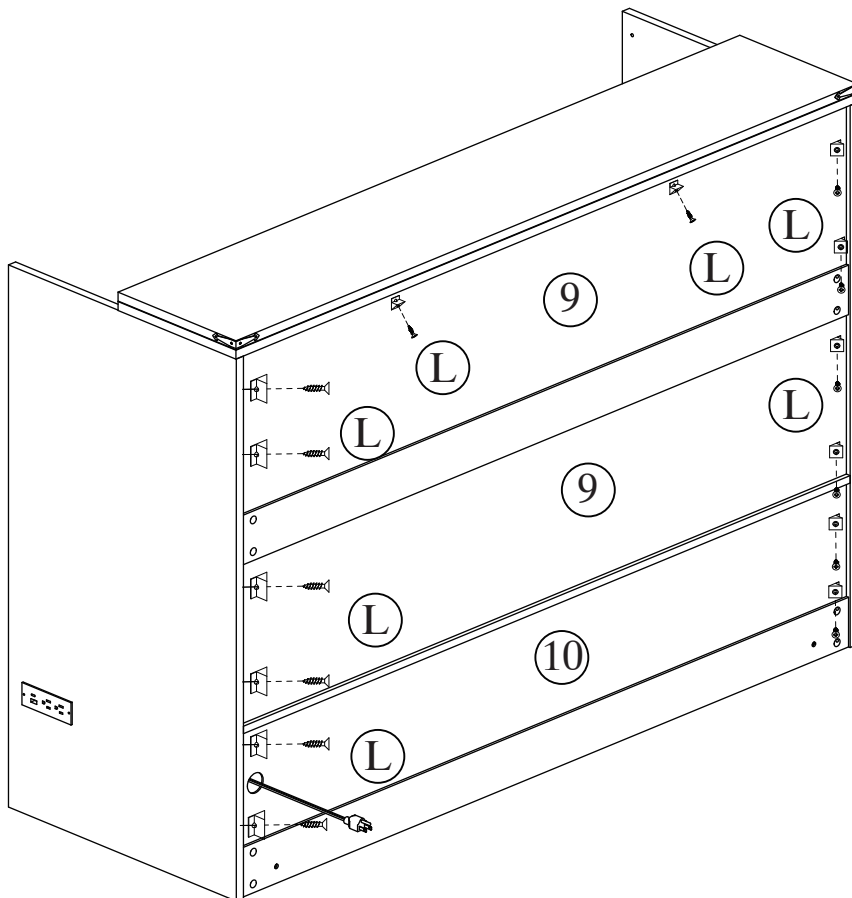
Étape



(L)			14
-----	---	---	----

STEP 21:

Étape

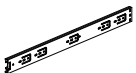
U		4*14mm	07
Y			01

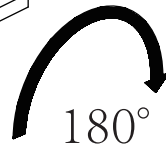
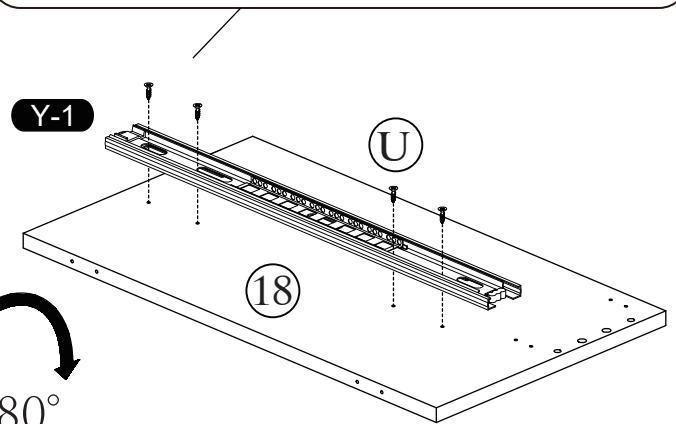
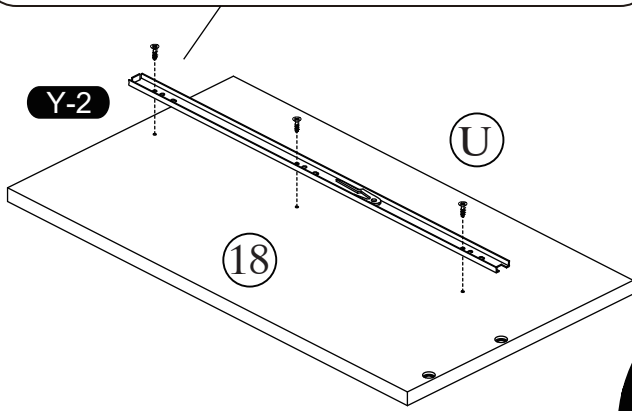
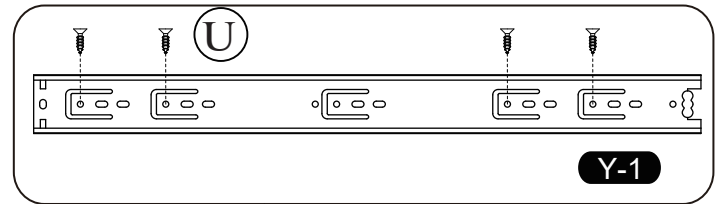
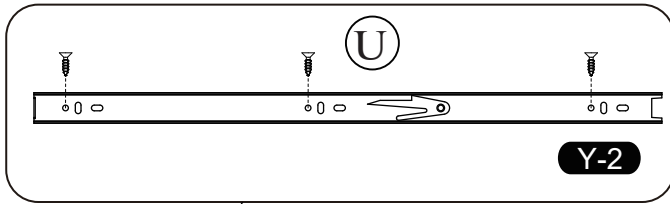

180°
Turn the panel over

STEP 22:

Étape

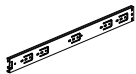
U		4*14mm	07
Y			01

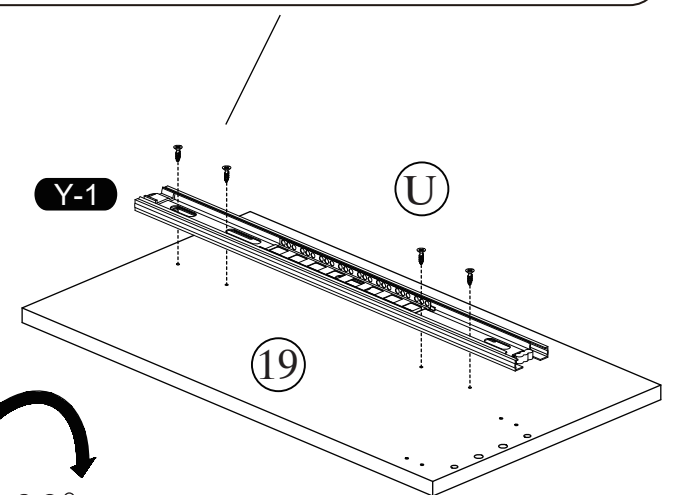
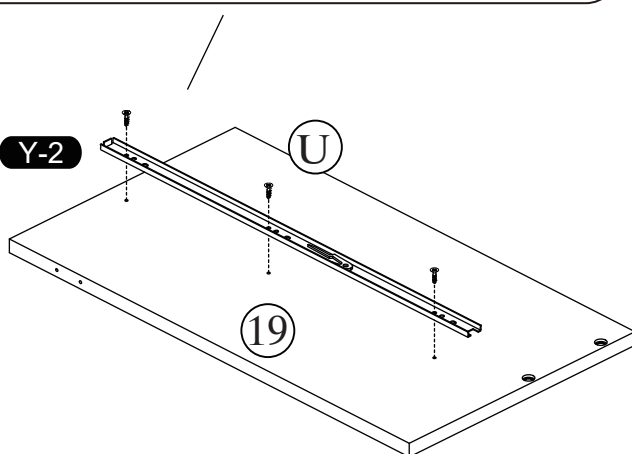
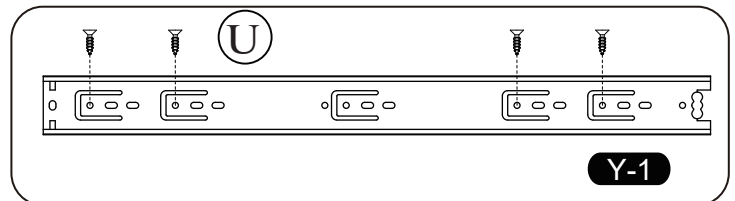
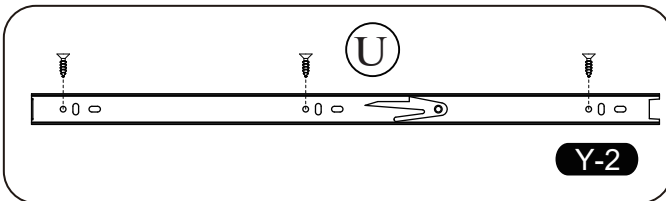



180°
Turn the panel over

STEP 23:

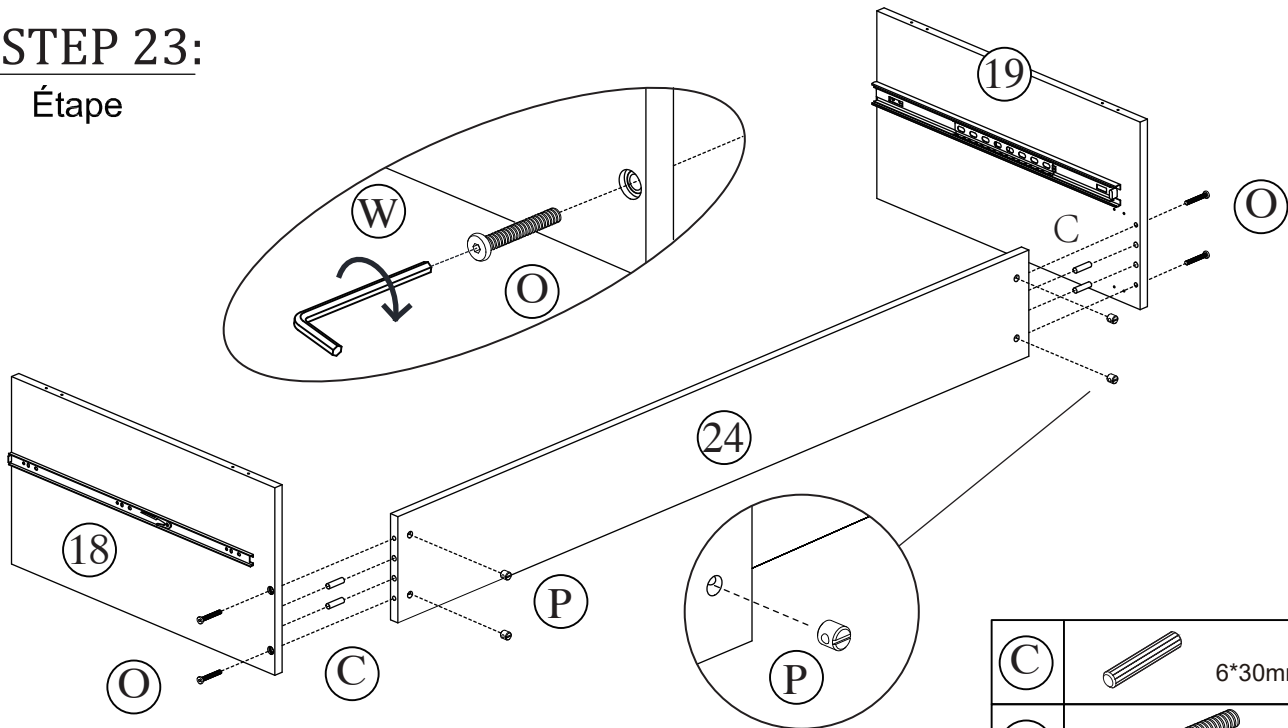
Étape

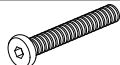



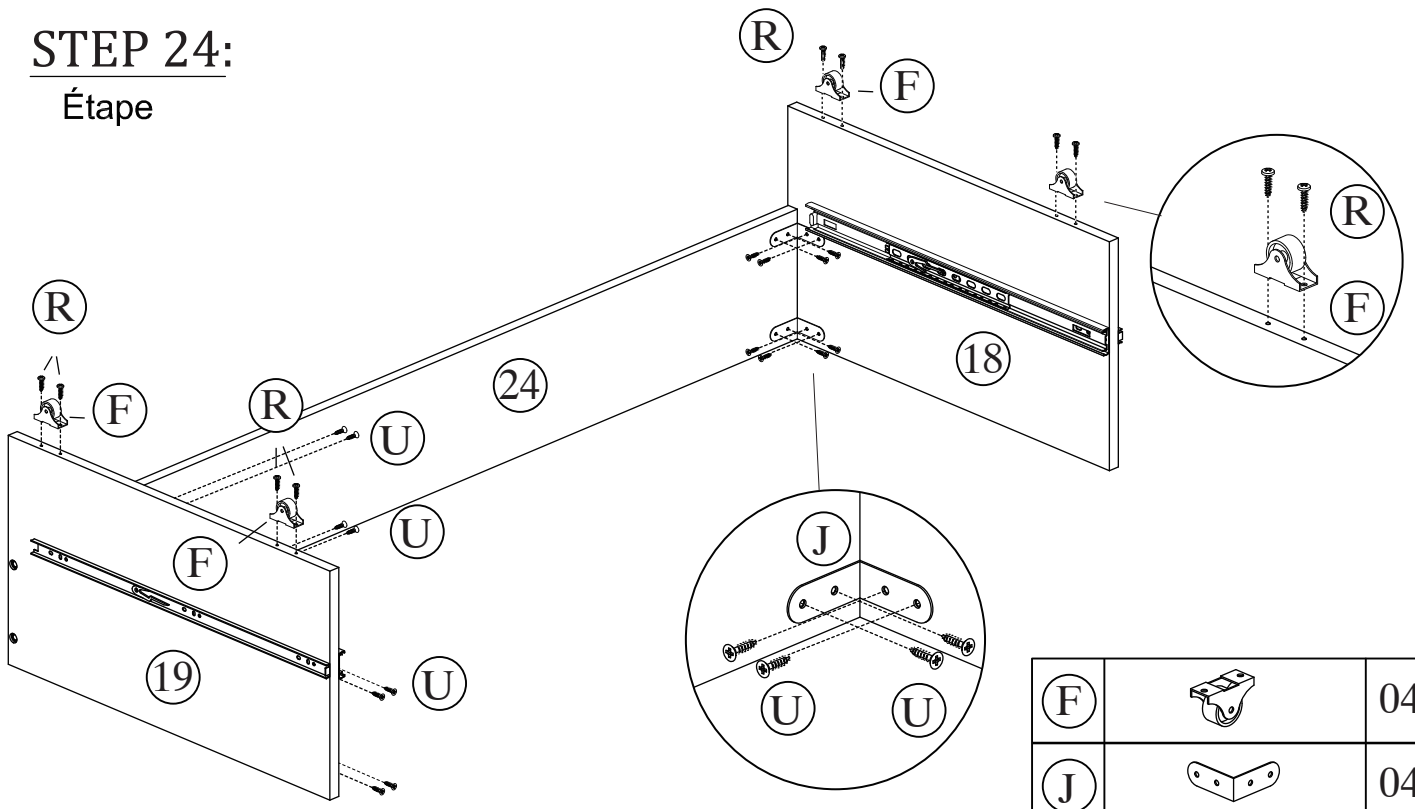

(C)		6*30mm	04
(O)			04
(P)			04
(W)			01

STEP 24:

Étape



(F)			04
(J)			04
(R)		4*18mm	08
(U)		4*14mm	16

STEP 25:

Étape

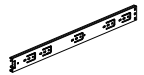
U		4*14mm	07
Y			01

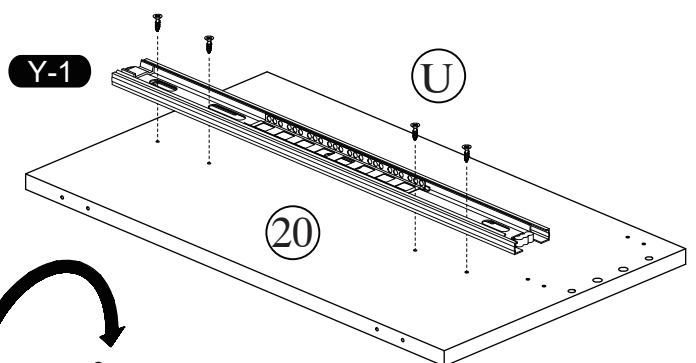
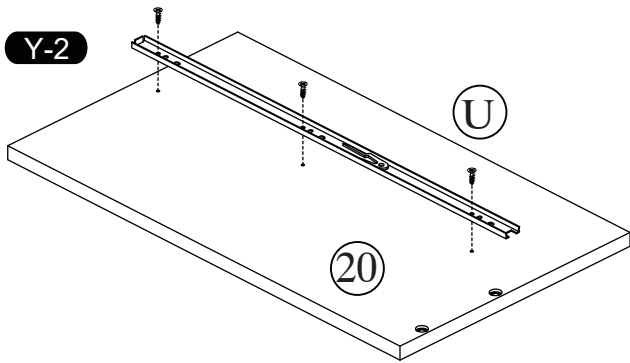
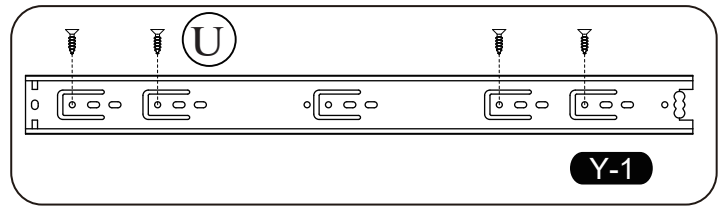
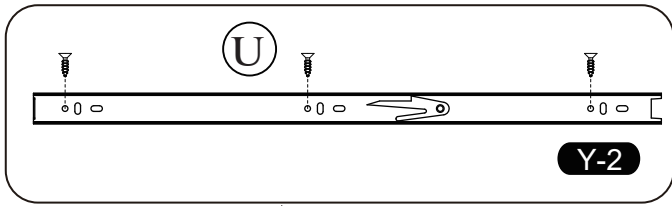

Turn the panel over

STEP 26:

Étape

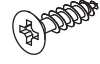
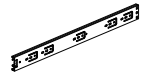
U		4*14mm	07
Y			01

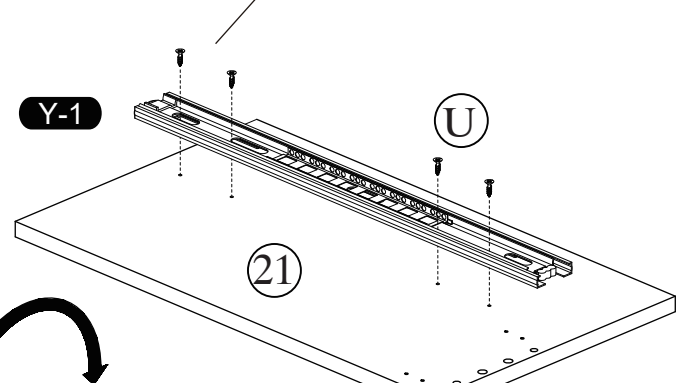
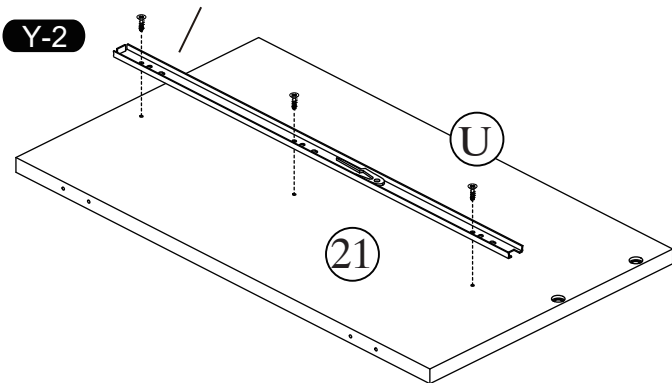
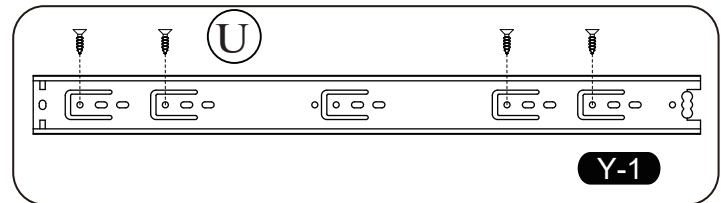
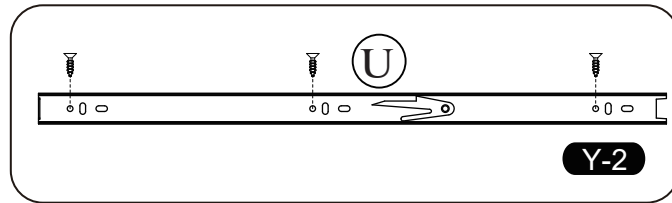



Turn the panel over

STEP 27:

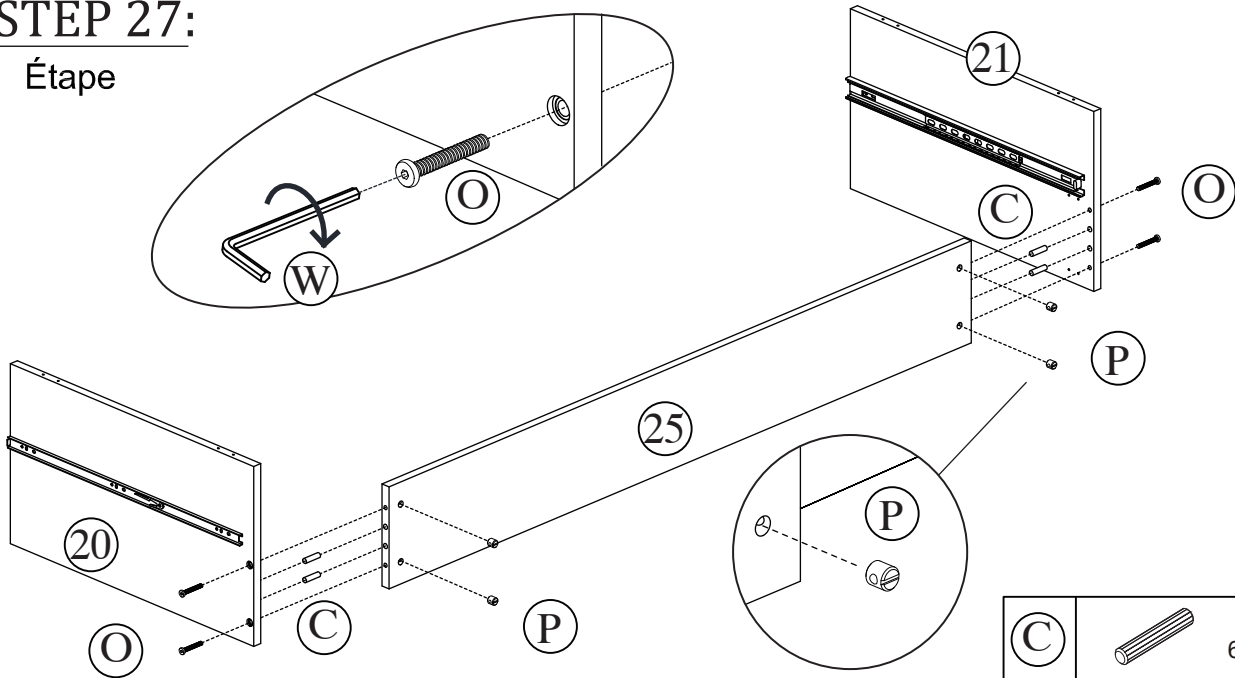
Étape

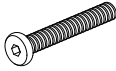



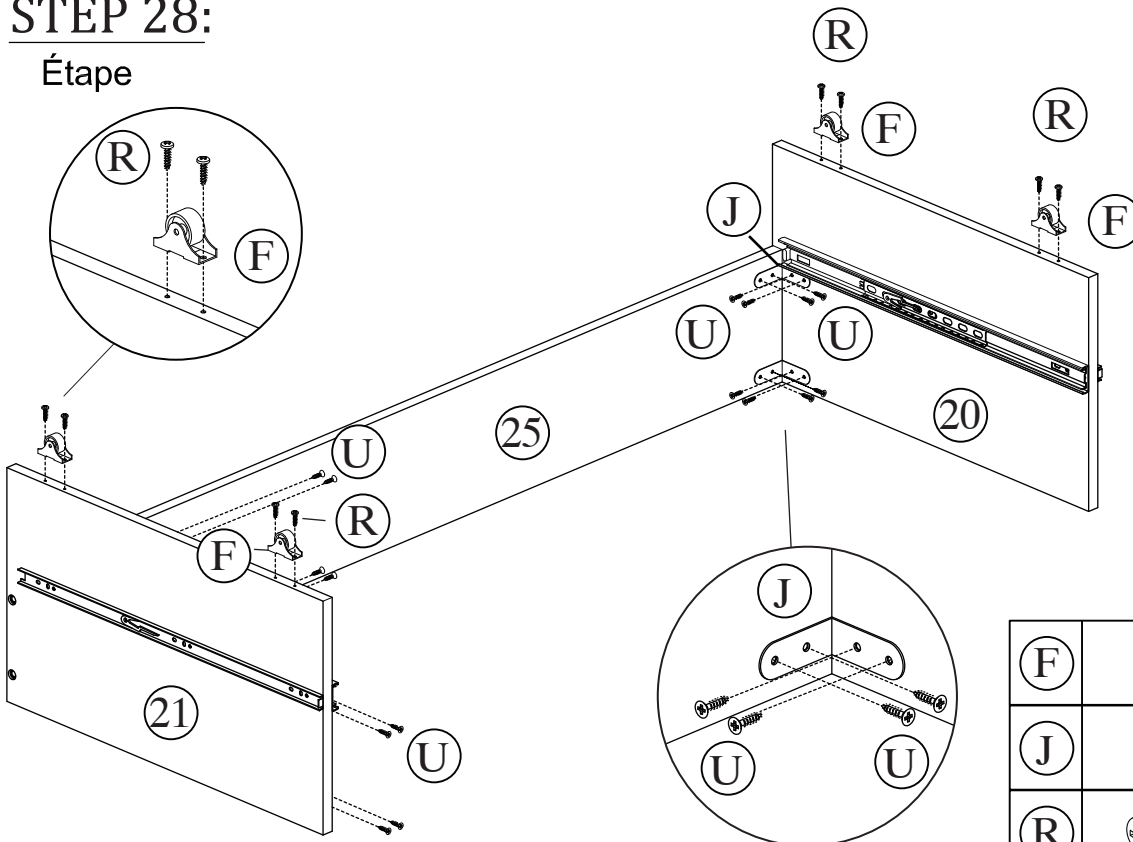

(C)	 6*30mm	04
(O)		04
(P)		04
(W)		01

STEP 28:

Étape



(F)		04
(J)		04
(R)	 4*18mm	08
(U)	 4*14mm	16

STEP 29:

Étape

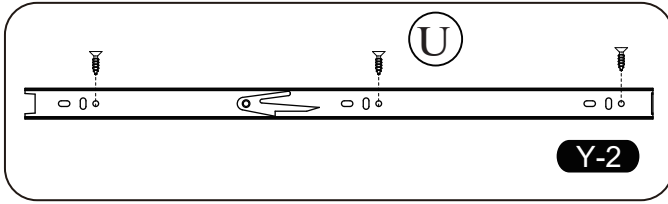

(F)		02
(R)		04
(U)		03
(Y)		01

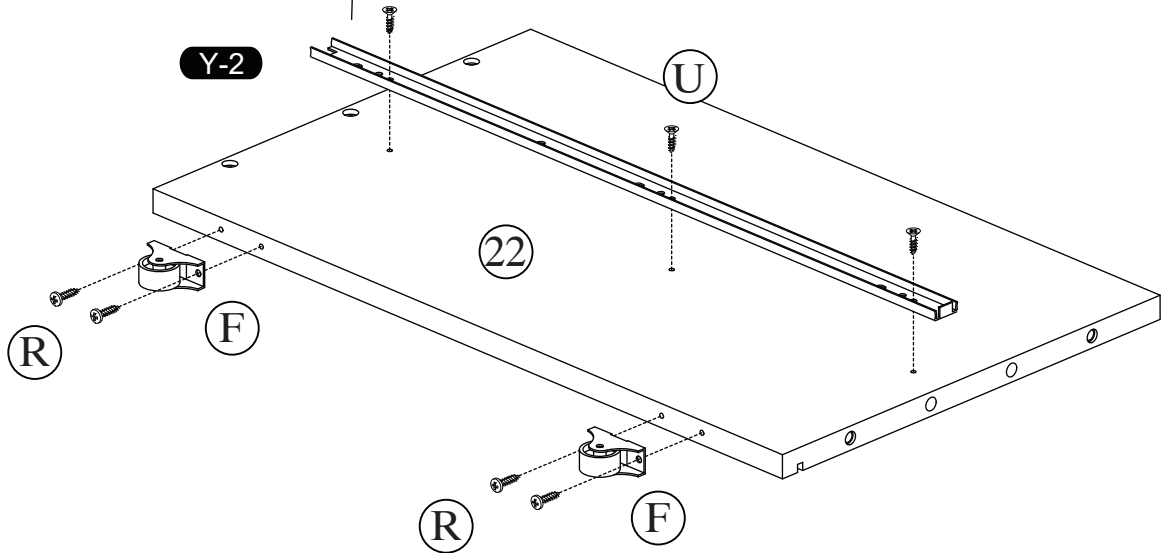

STEP 30:

Étape

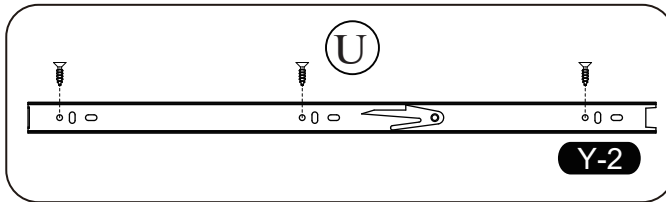

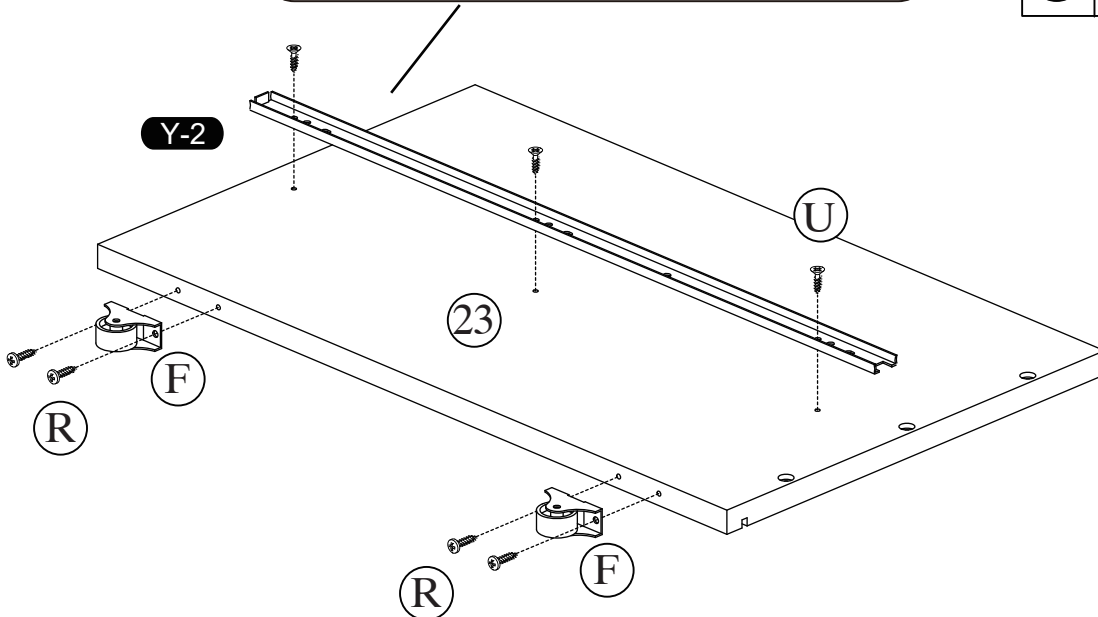

(F)		02
(R)		04
(U)		03
(Y)		01

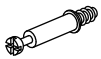
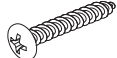
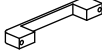

STEP 31:

Étape

(A)		06
(N)	 4*20mm	06
(X)	  	02

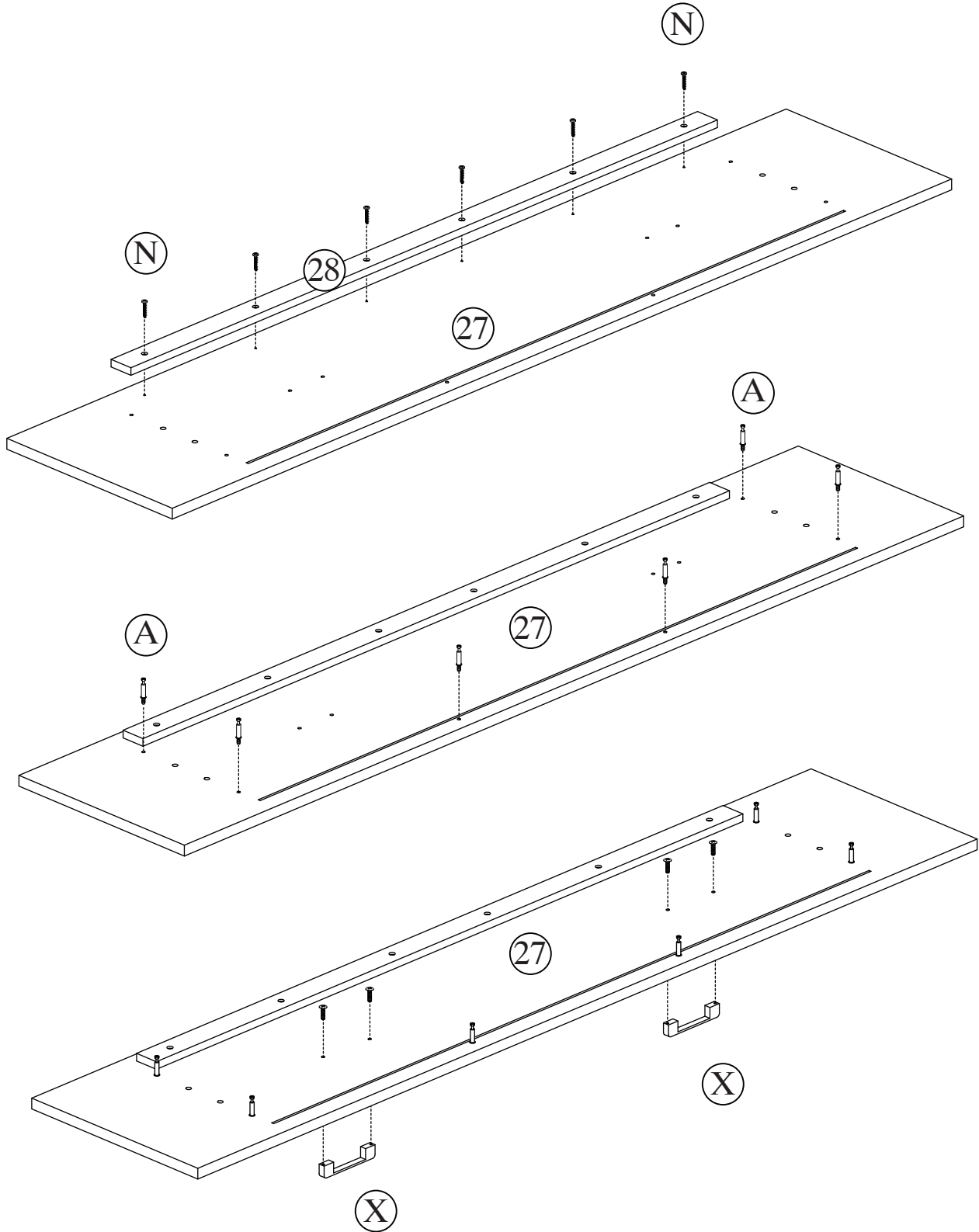

STEP 32:

Étape

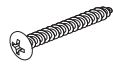
Q		4*40mm	06
---	--	--------	----

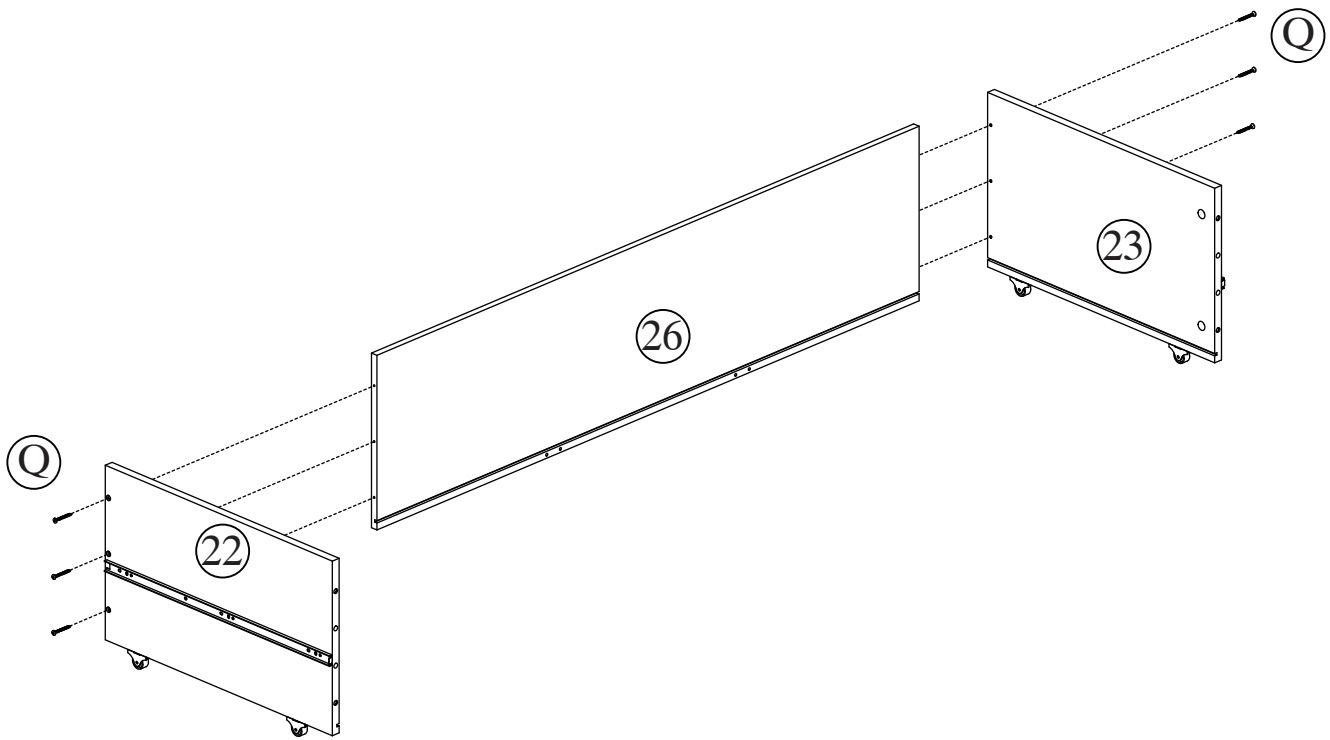

STEP 33:

Étape

Q		4*40mm	04
---	---	--------	----

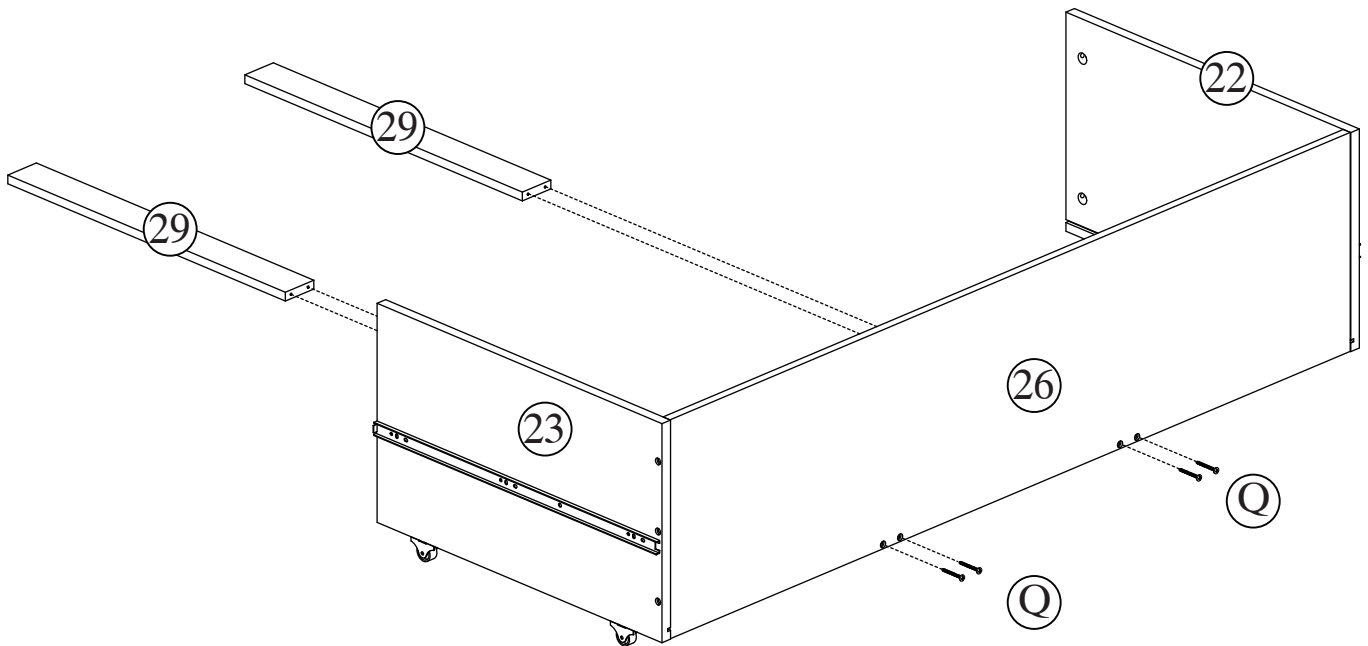

STEP 34:

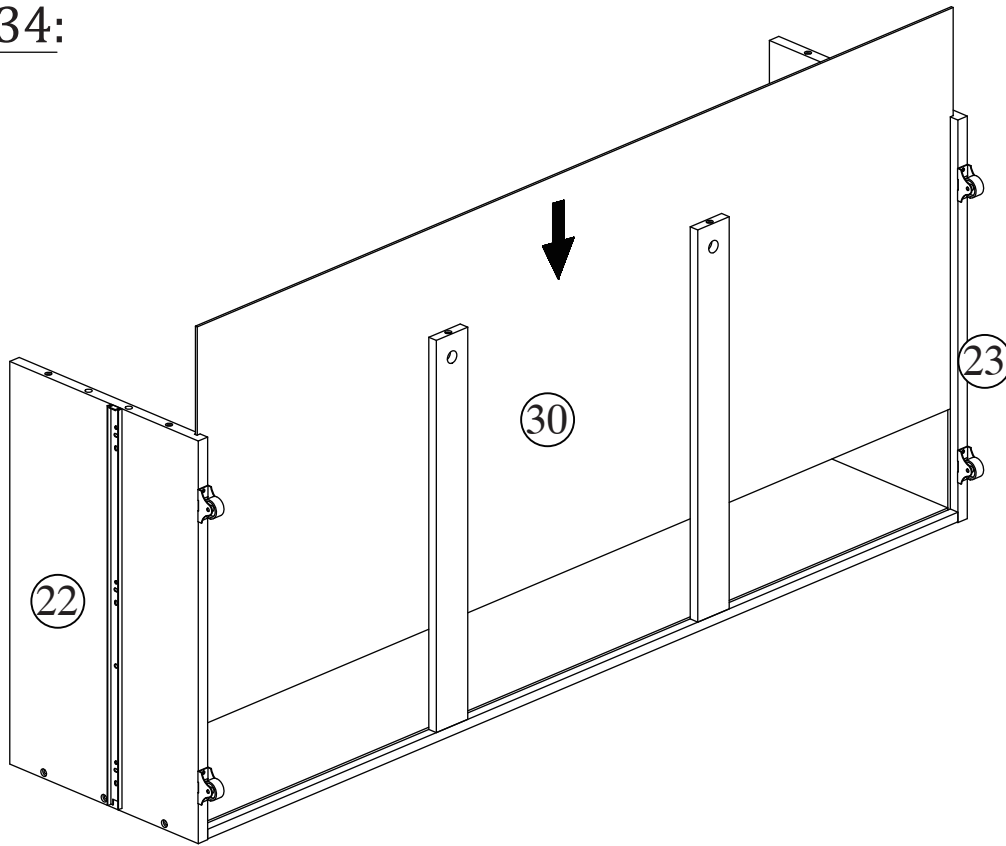

Étape

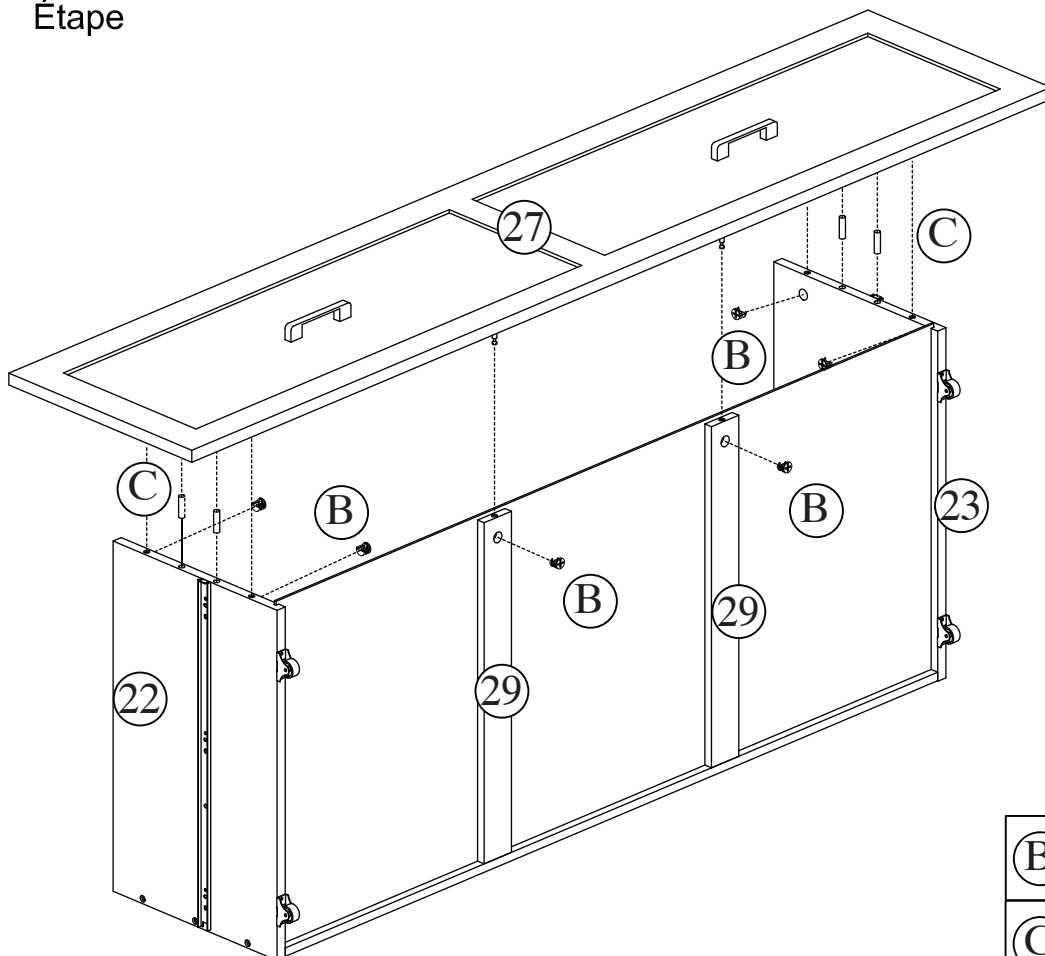

STEP 35:

Étape



(B)		06
(C)	 6*30mm	04

STEP 36:

Étape

Please make sure that the balls in the tracks on both sides are pulled to the top, and then insert the tracks to ensure smooth entry.

Veuillez vous assurer que les billes dans les rails des deux côtés sont tirées vers le haut, puis insérez les rails pour garantir une entrée sans heurt..

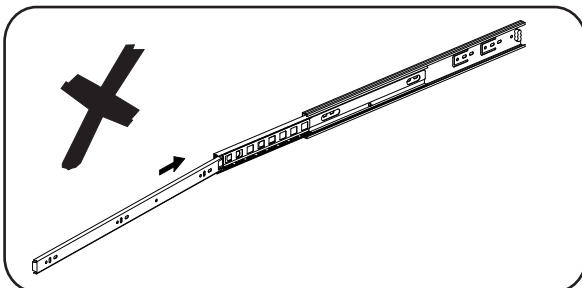
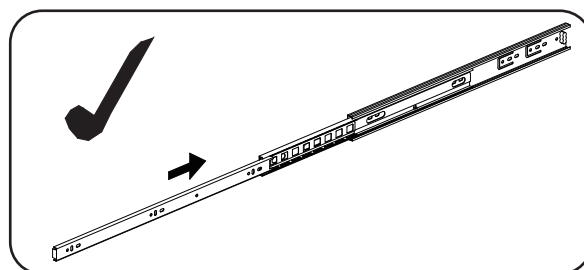
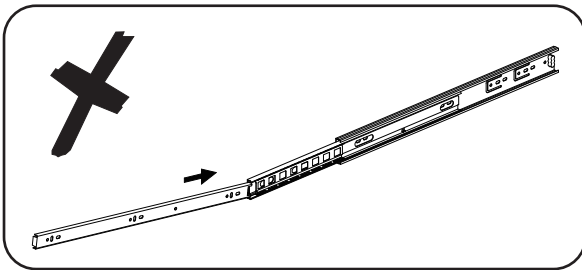
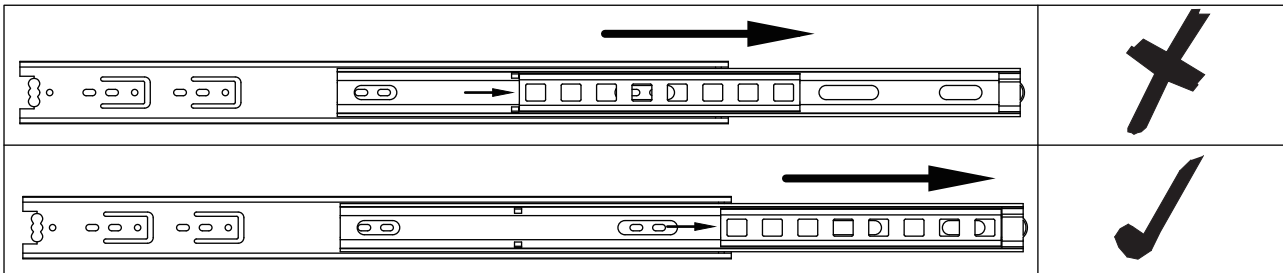

1. Drawers must be horizontally put into the cabinets.
2. Make sure both sides sliders match well to avoid damage.

1. Les tiroirs doivent être horizontalement mis dans les armoires.
2. Assurez-vous que les curseurs des deux côtés s'assortissent bien pour éviter les dommages.

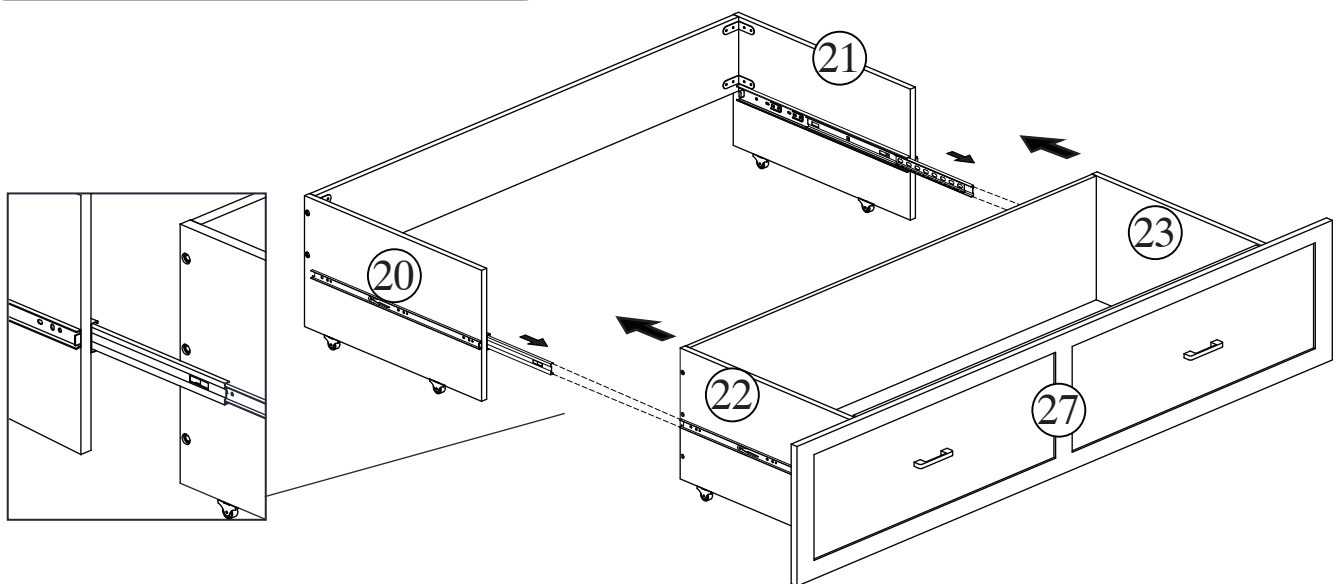

Try to find a partner to install with you.

Essayez de trouver un partenaire à installer avec vous.

STEP 37:

Étape

Please make sure that the balls in the tracks on both sides are pulled to the top, and then insert the tracks to ensure smooth entry.

Veuillez vous assurer que les billes dans les rails des deux côtés sont tirées vers le haut, puis insérez les rails pour garantir une entrée sans heurt..

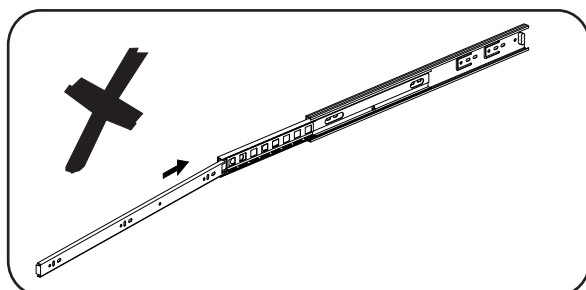
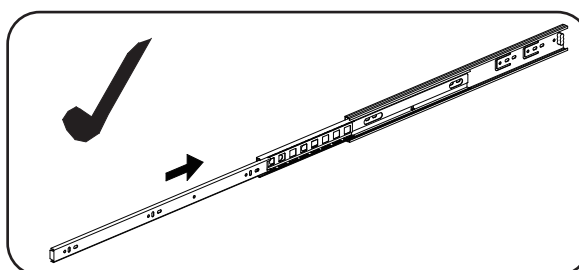
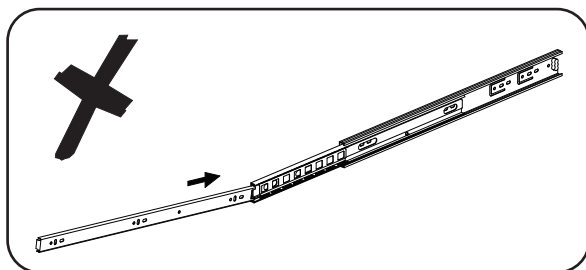
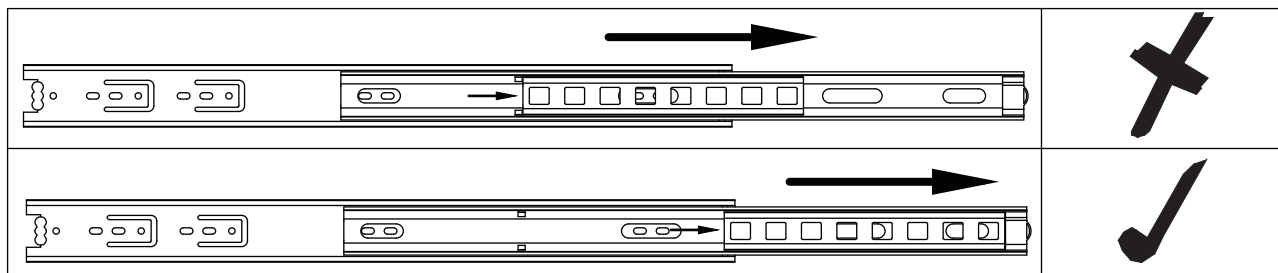

1. Drawers must be horizontally put into the cabinets.
2. Make sure both sides sliders match well to avoid damage.

1. Les tiroirs doivent être horizontalement mis dans les armoires.
2. Assurez-vous que les curseurs des deux côtés s'assortissent bien pour éviter les dommages.

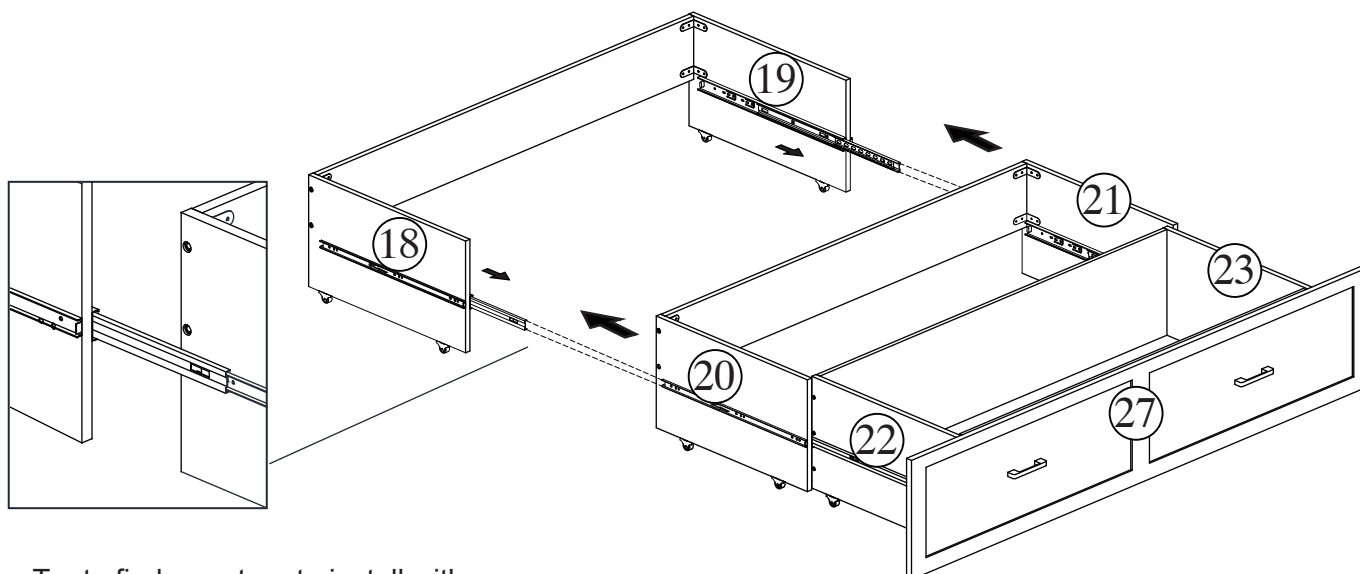

Try to find a partner to install with you.
Essayez de trouver un partenaire à installer avec vous.

STEP 38:

Étape

Please make sure that the balls in the tracks on both sides are pulled to the top, and then insert the tracks to ensure smooth entry.

Veillez vous assurer que les billes dans les rails des deux côtés sont tirées vers le haut, puis insérez les rails pour garantir une entrée sans heurt.

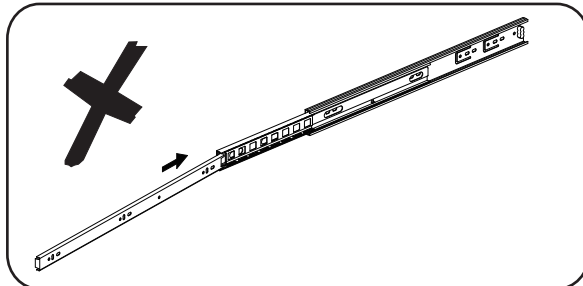
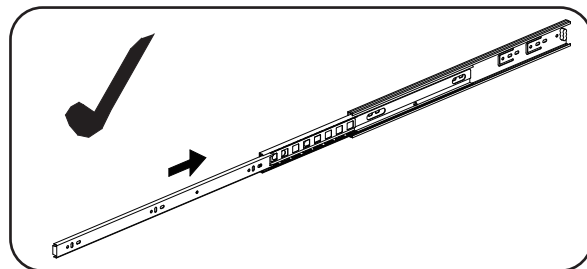
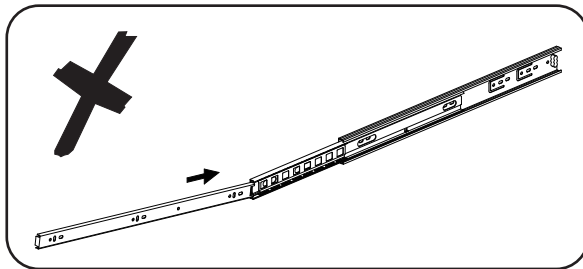
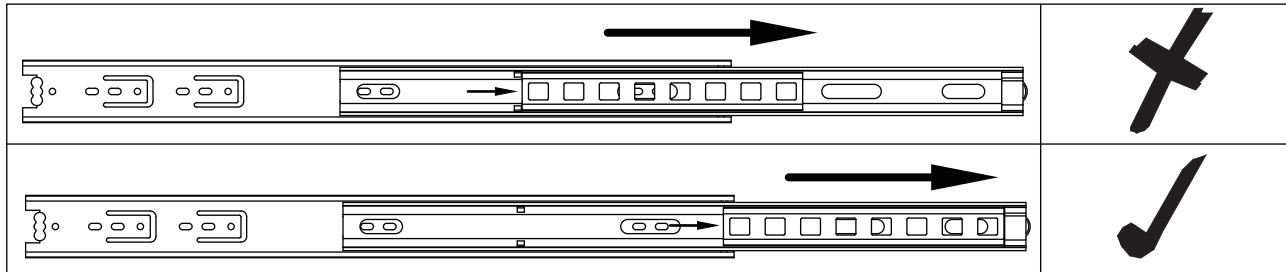

1. Drawers must be horizontally put into the cabinets.
 2. Make sure both sides sliders match well to avoid damage.
1. Les tiroirs doivent être horizontalement mis dans les armoires.
2. Assurez-vous que les curseurs des deux côtés s'assortissent bien pour éviter les dommages.

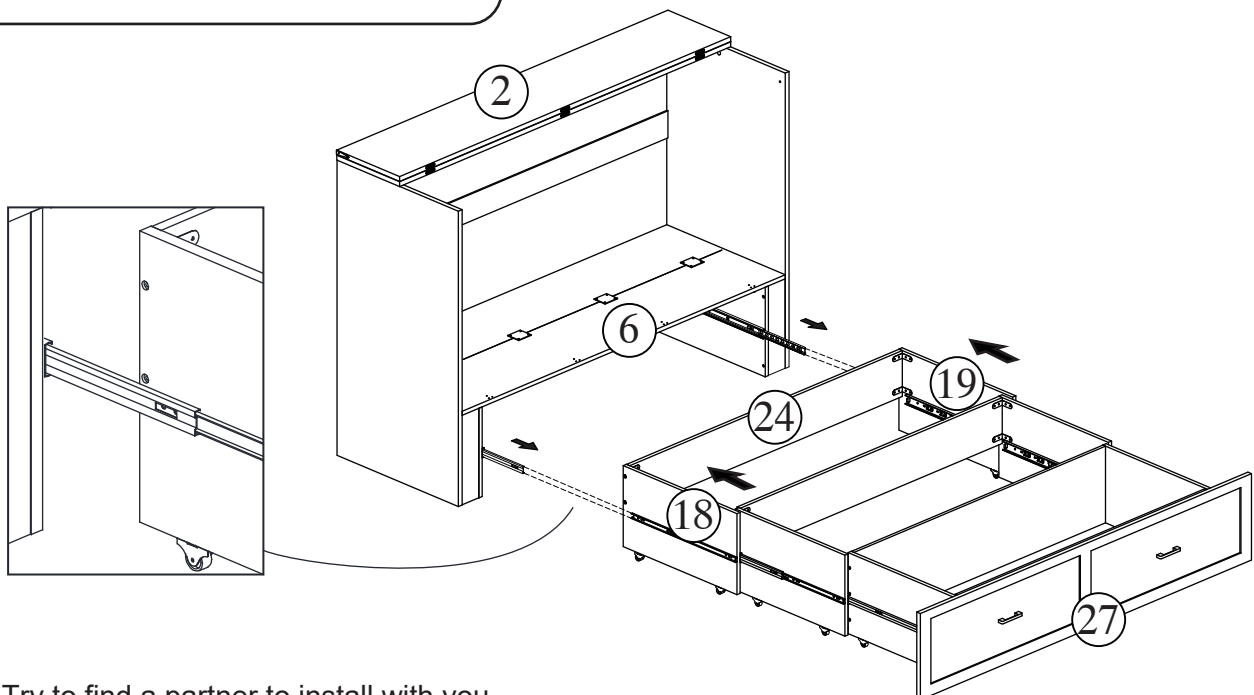

Try to find a partner to install with you.
Essayez de trouver un partenaire à installer avec vous.

STEP 39:

Étape

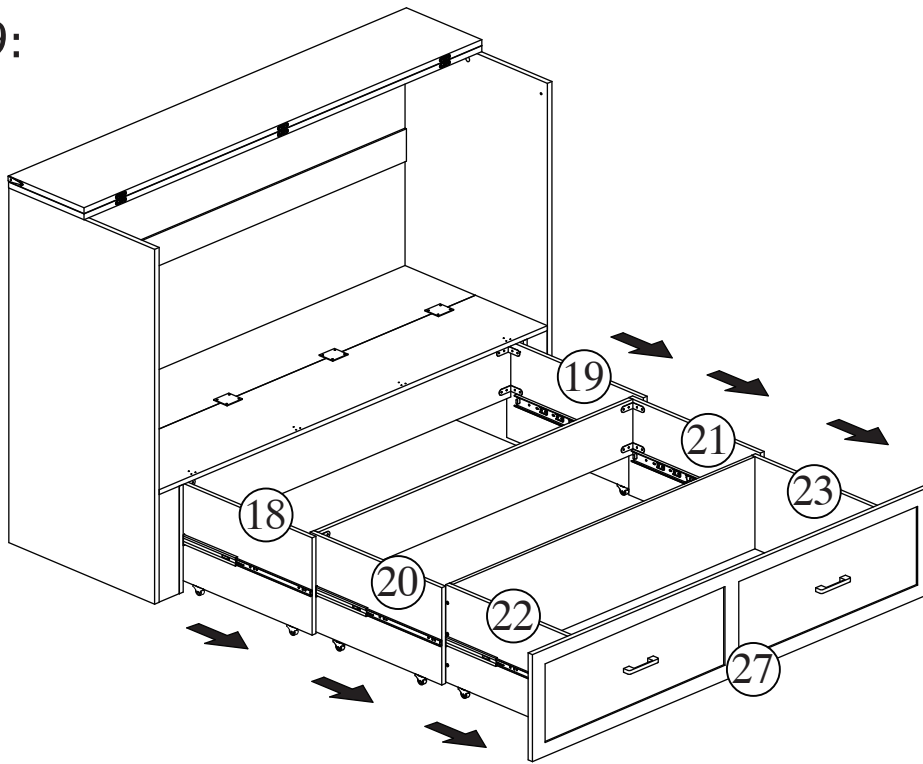

STEP 40:

Étape

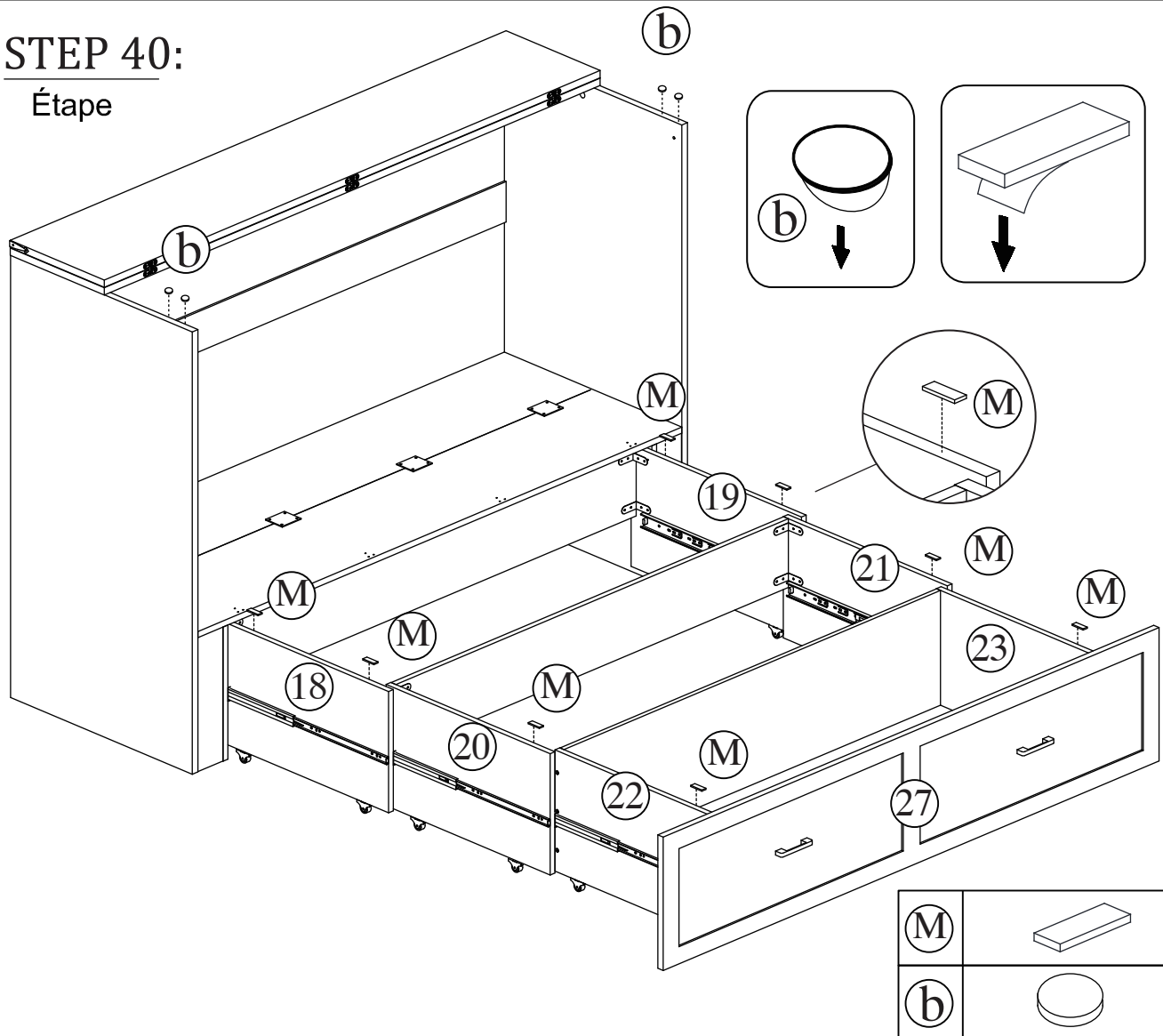

STEP 41:

Étape

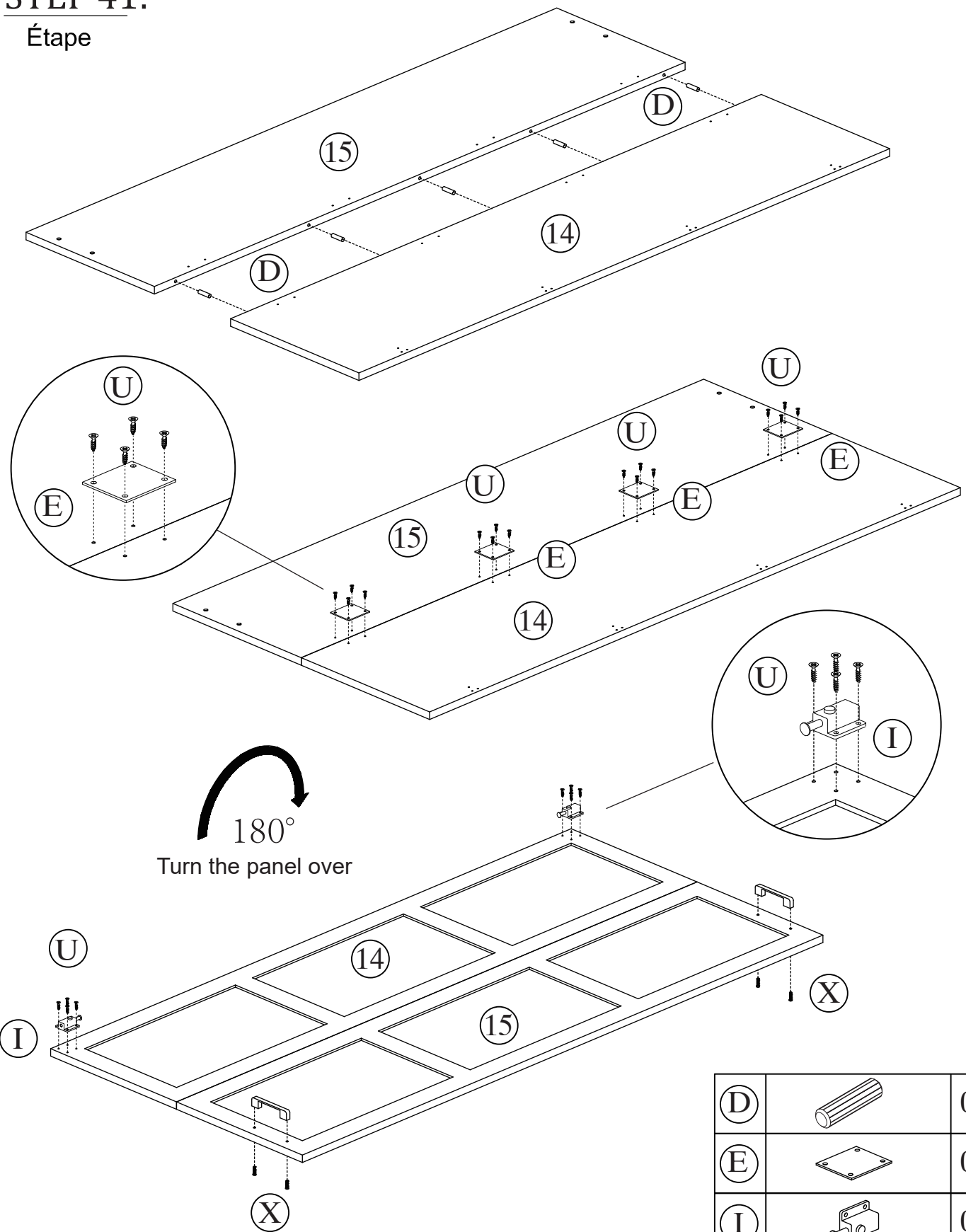

(D)		05
(E)		04
(I)		02
(U)		24
(X)		02

STEP 42:

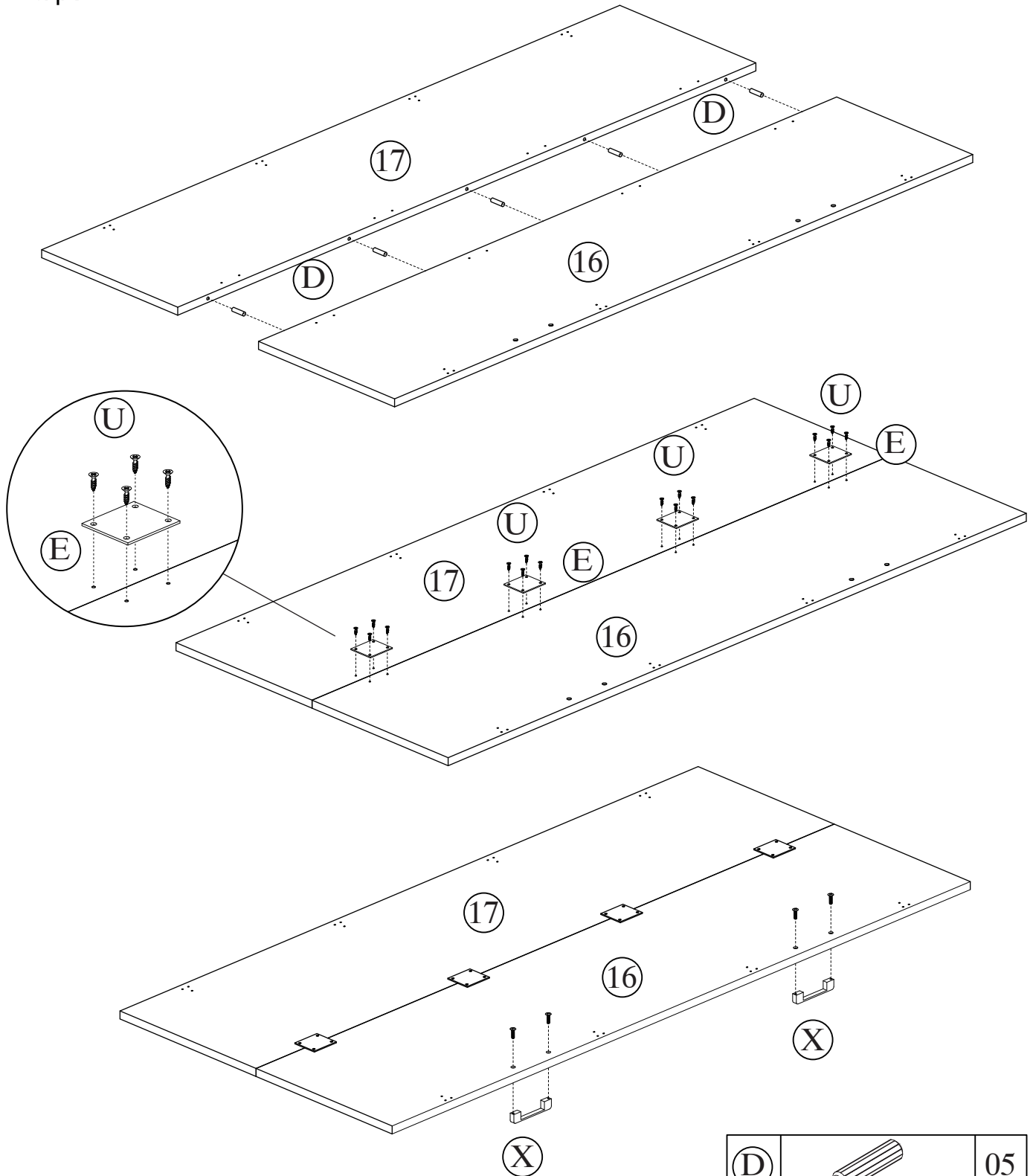

Étape



(D)		05
(E)		04
(U)		16
(X)		02

STEP 43:

Étape

G		08
U		48

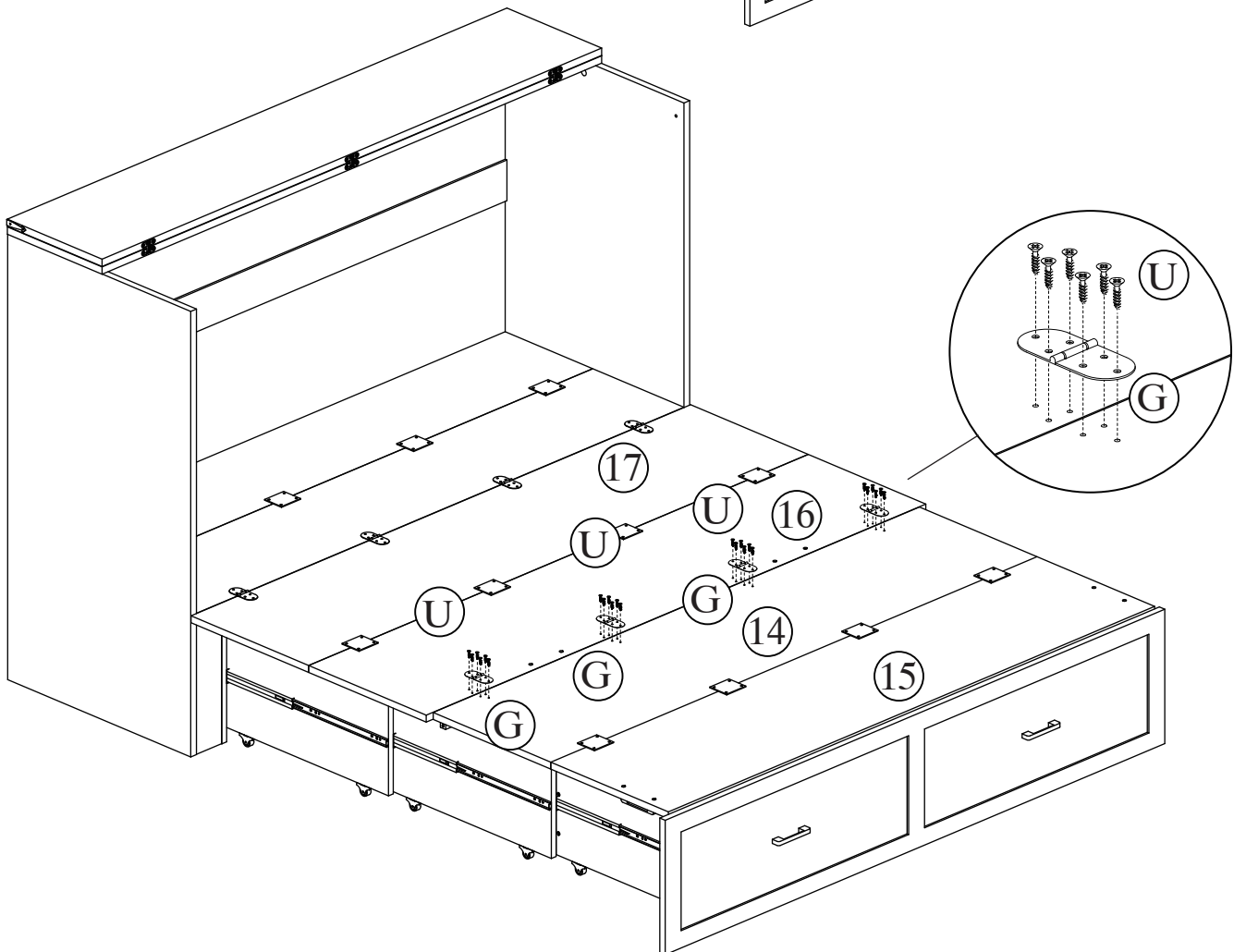
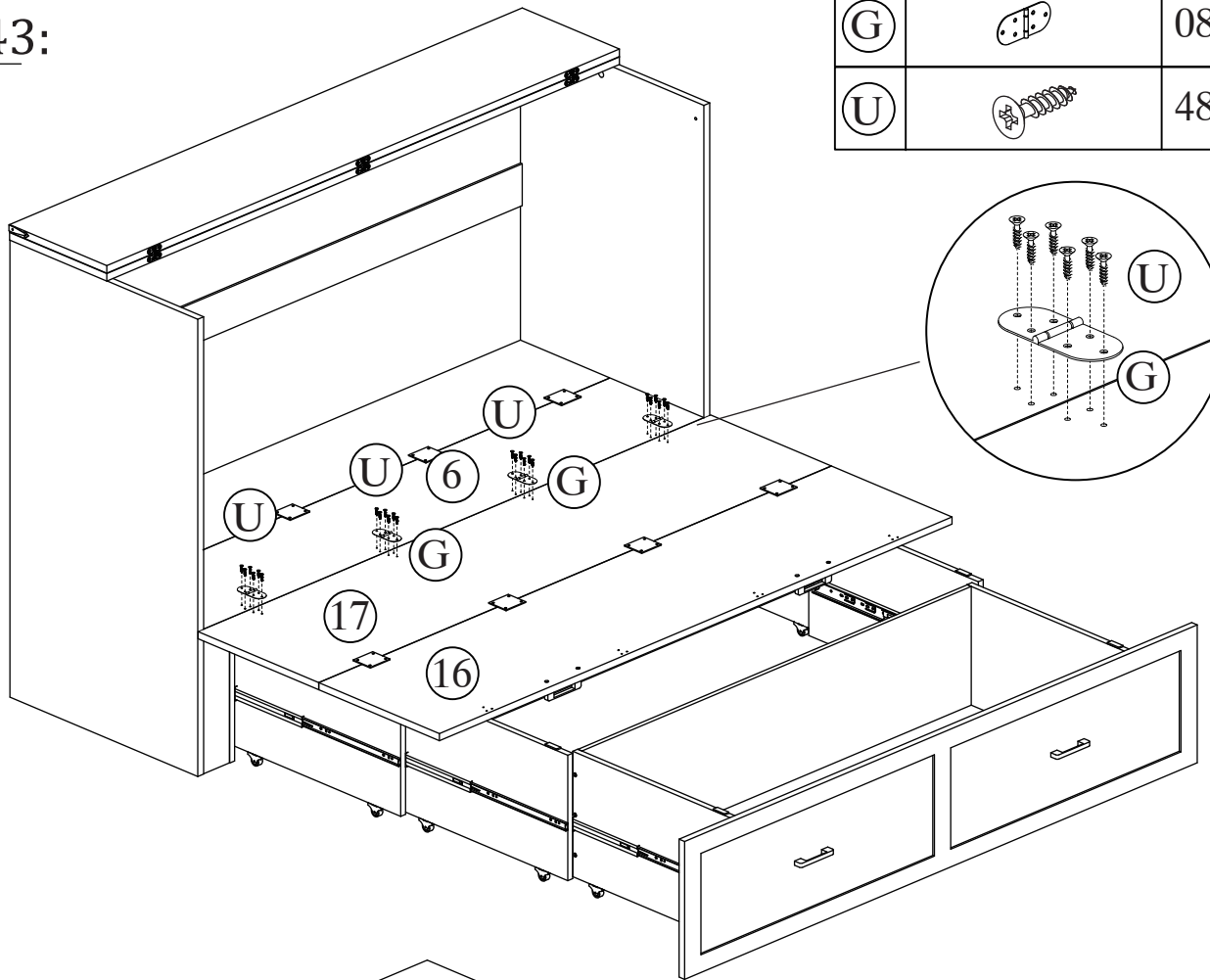

STEP 44:

Étape

a		04
---	--	----

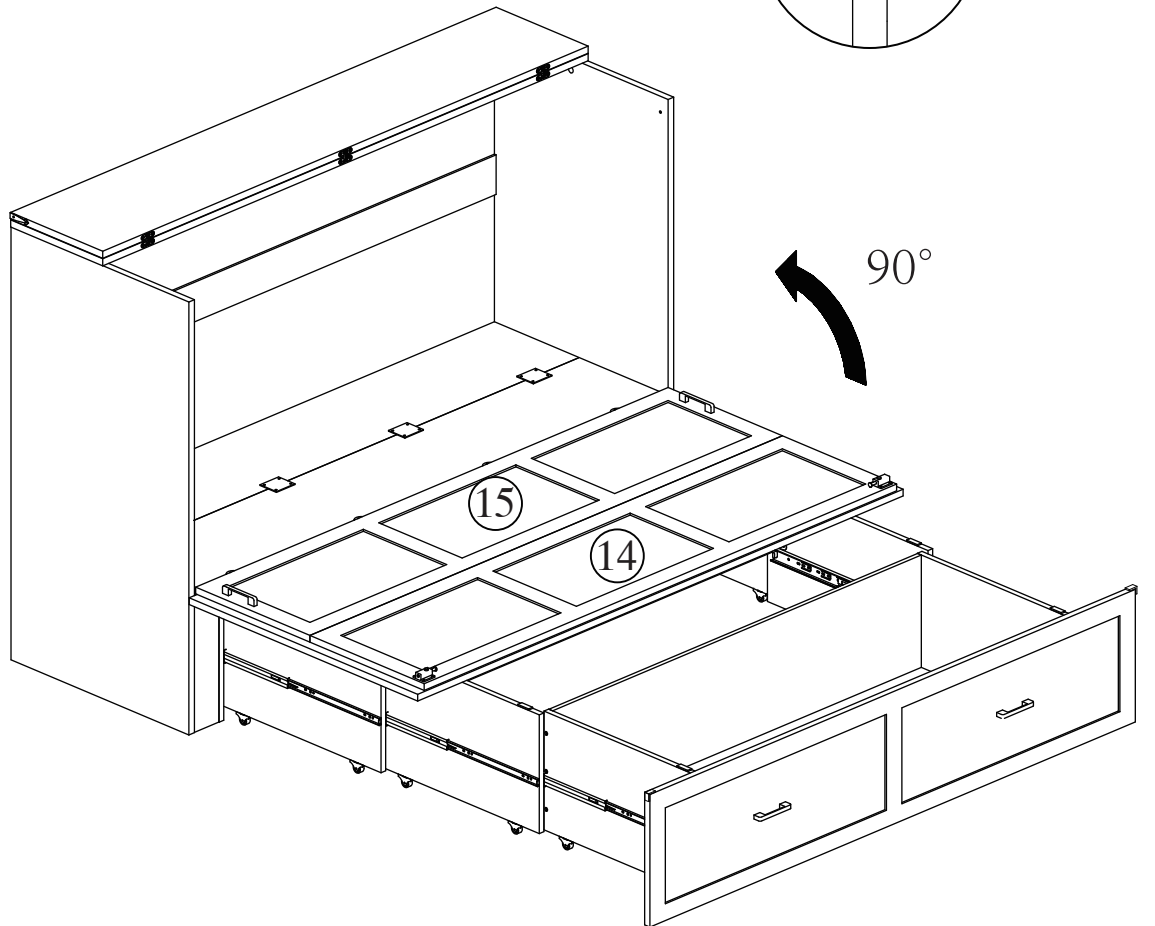
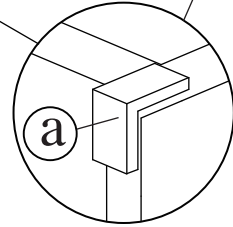
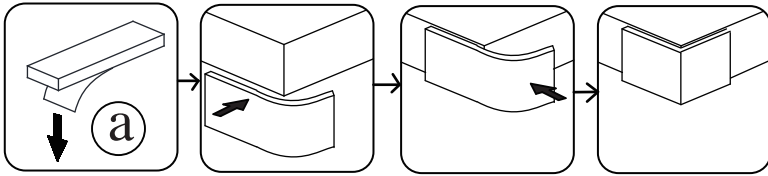
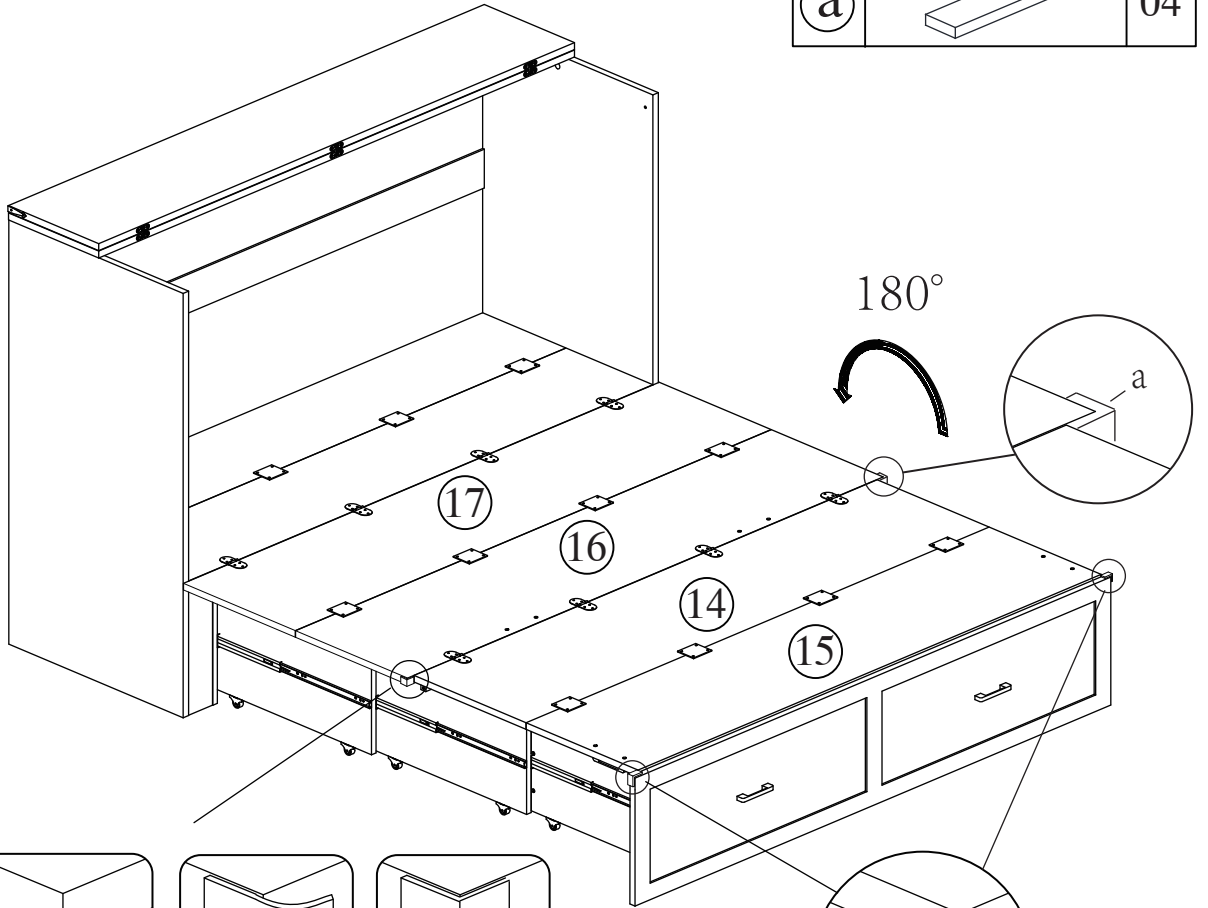

STEP 45:

Étape

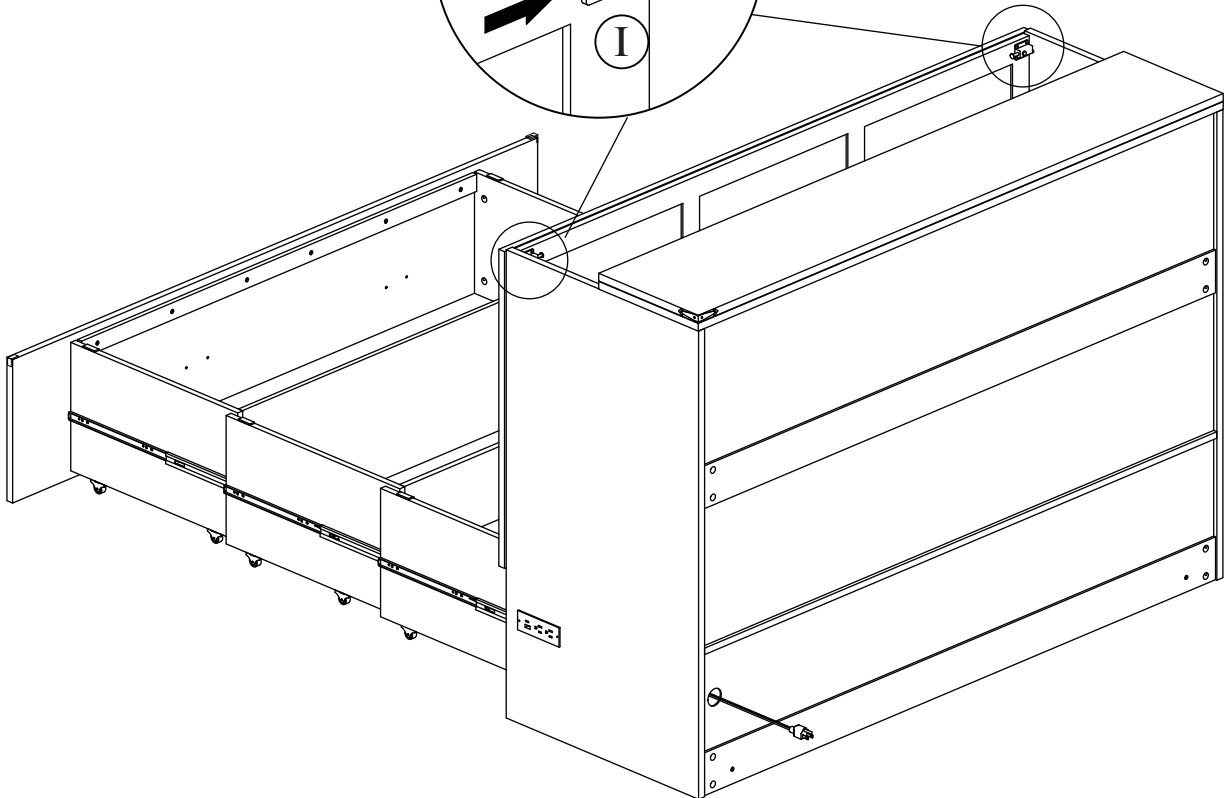
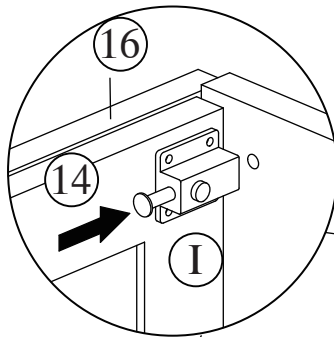
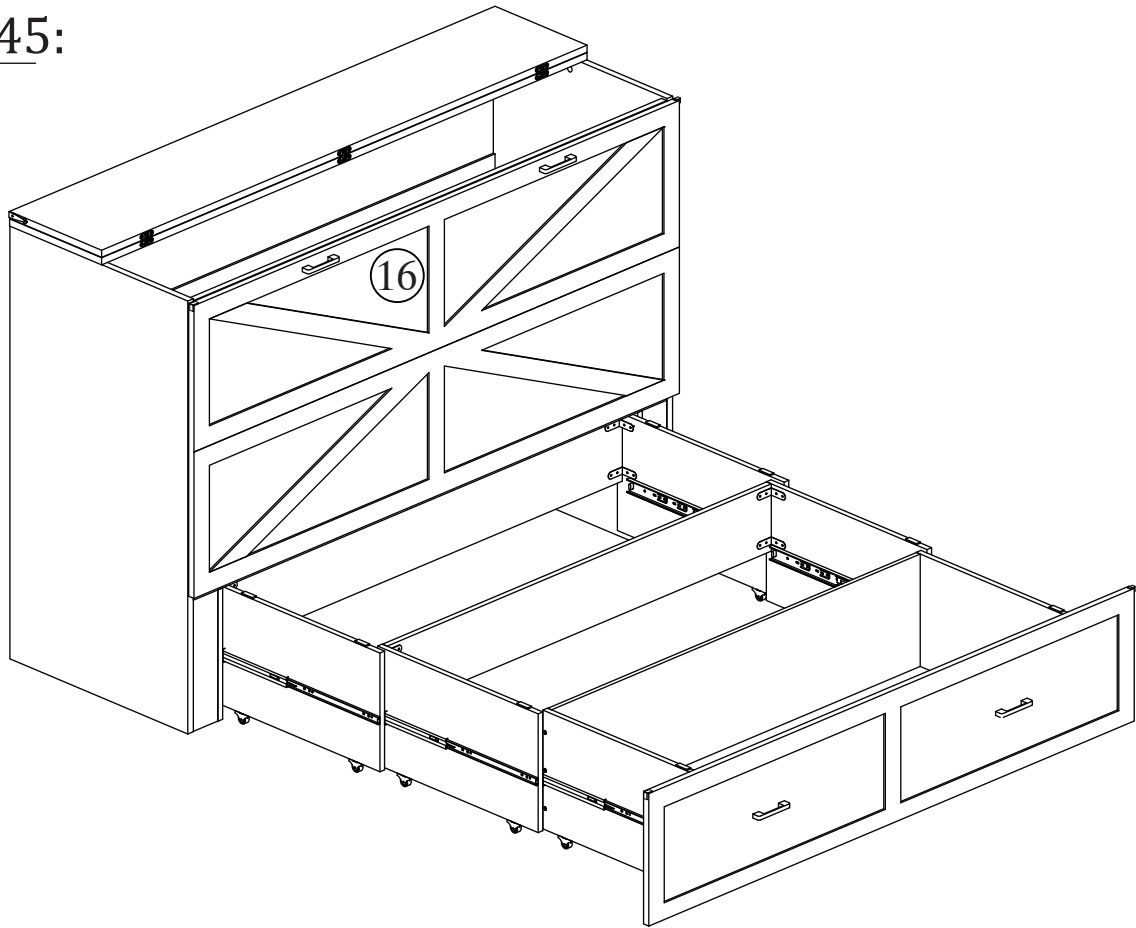

STEP 46:

Étape

180°

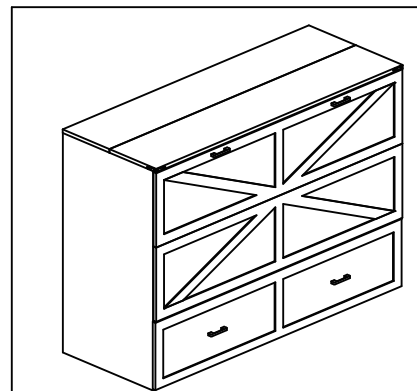
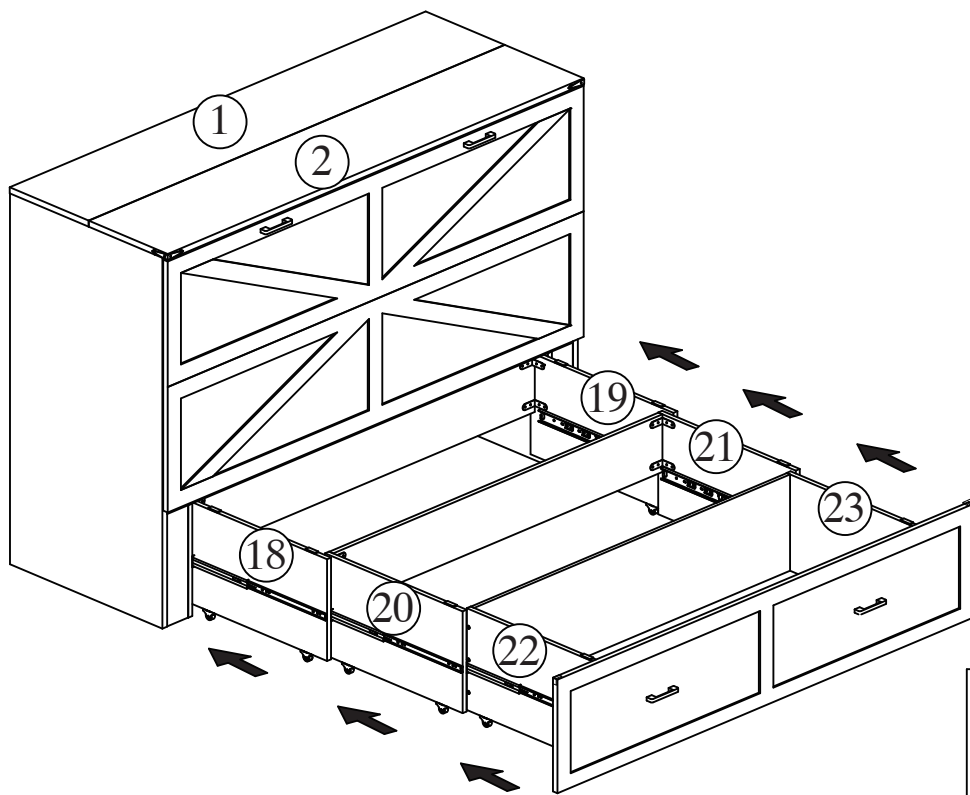
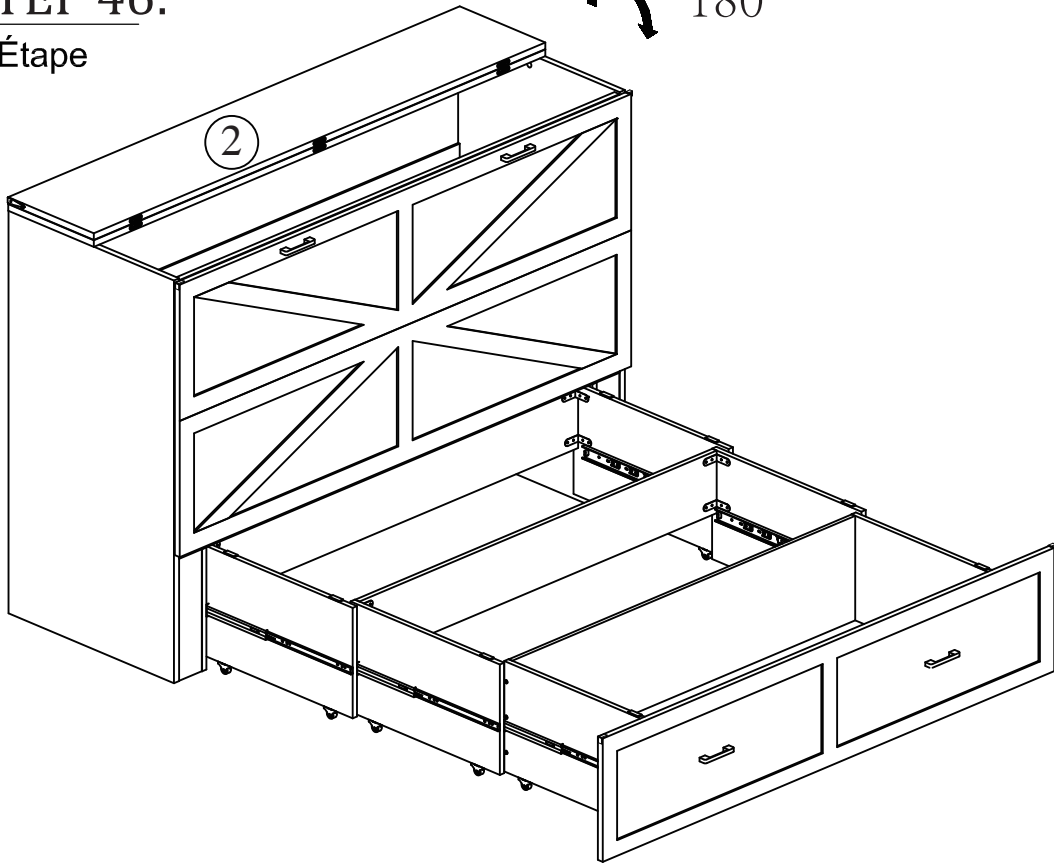

STEP 47:

Étape

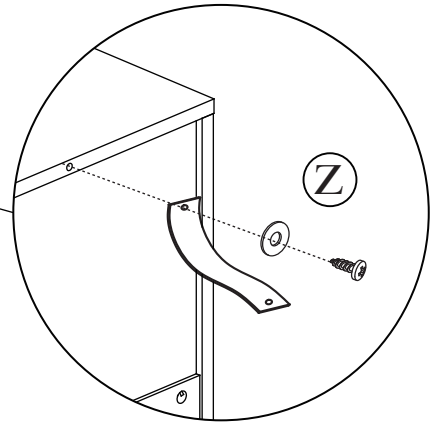
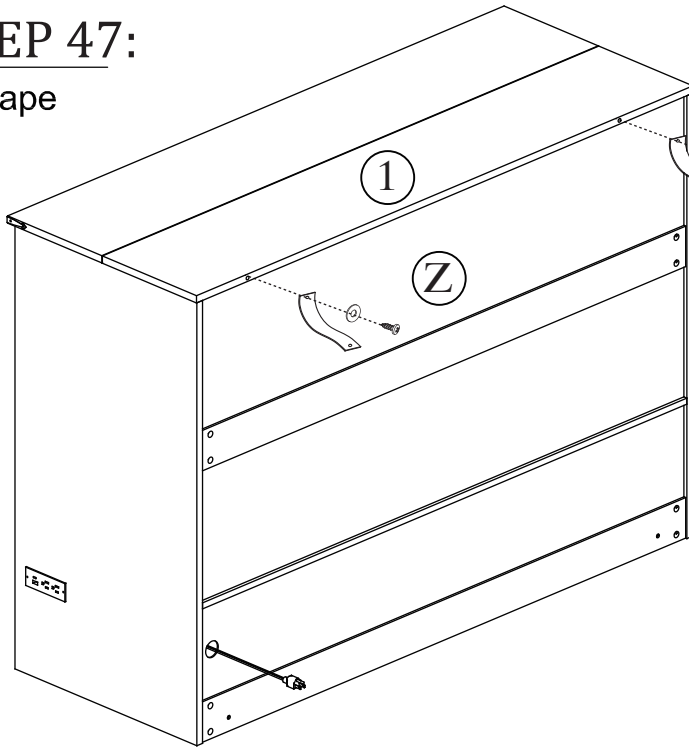

Wall

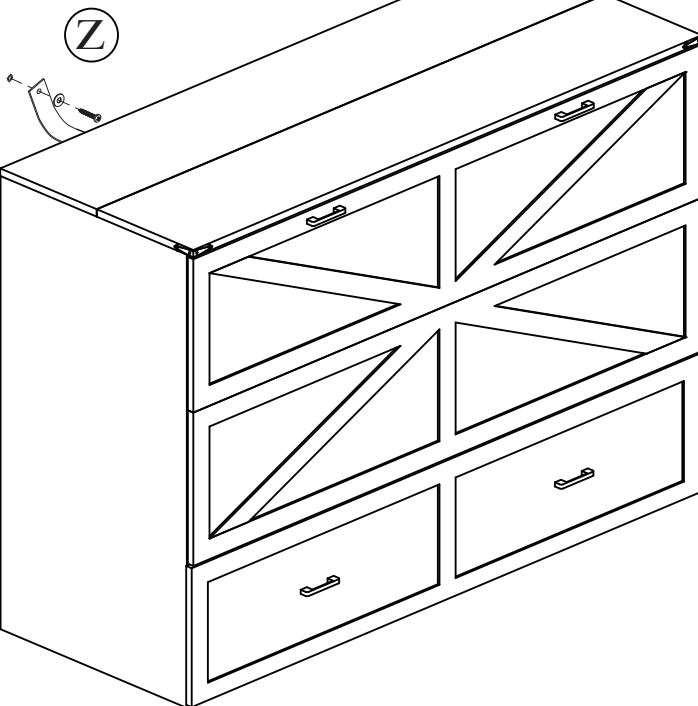
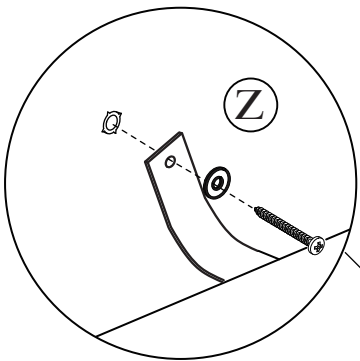

Position on the wall to align the plastic stopper(Z) with the hole positions on the patt(Z) at the bed's location.

Positionner sur le mur pour aligner la butée en plastique(Z) avec les positions des trous la patte(Z) à l'emplacement du lit.

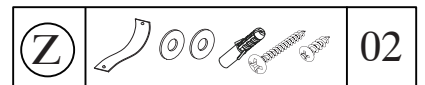

STEP 48:

Étape

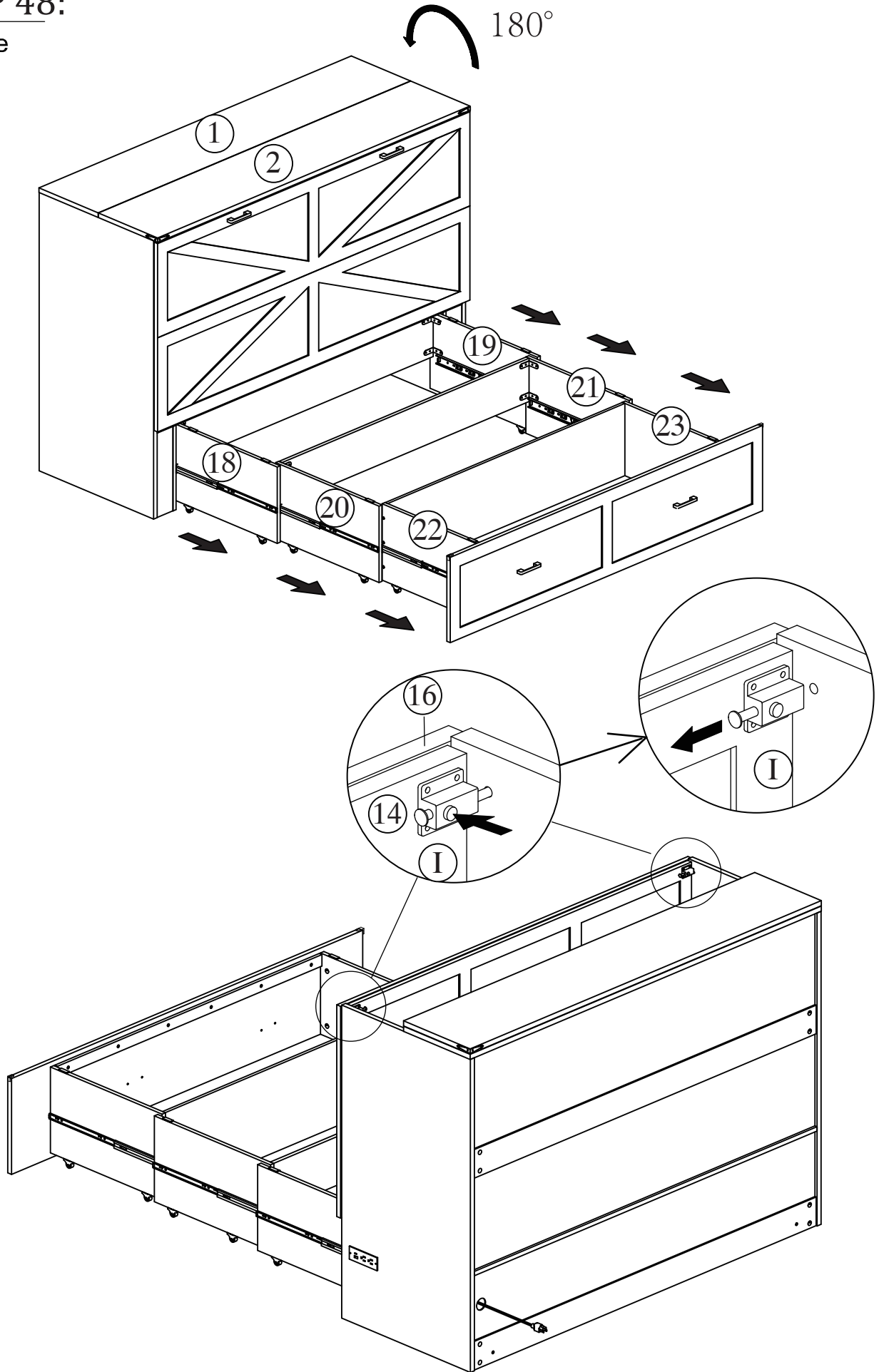

STEP 49:

Étape

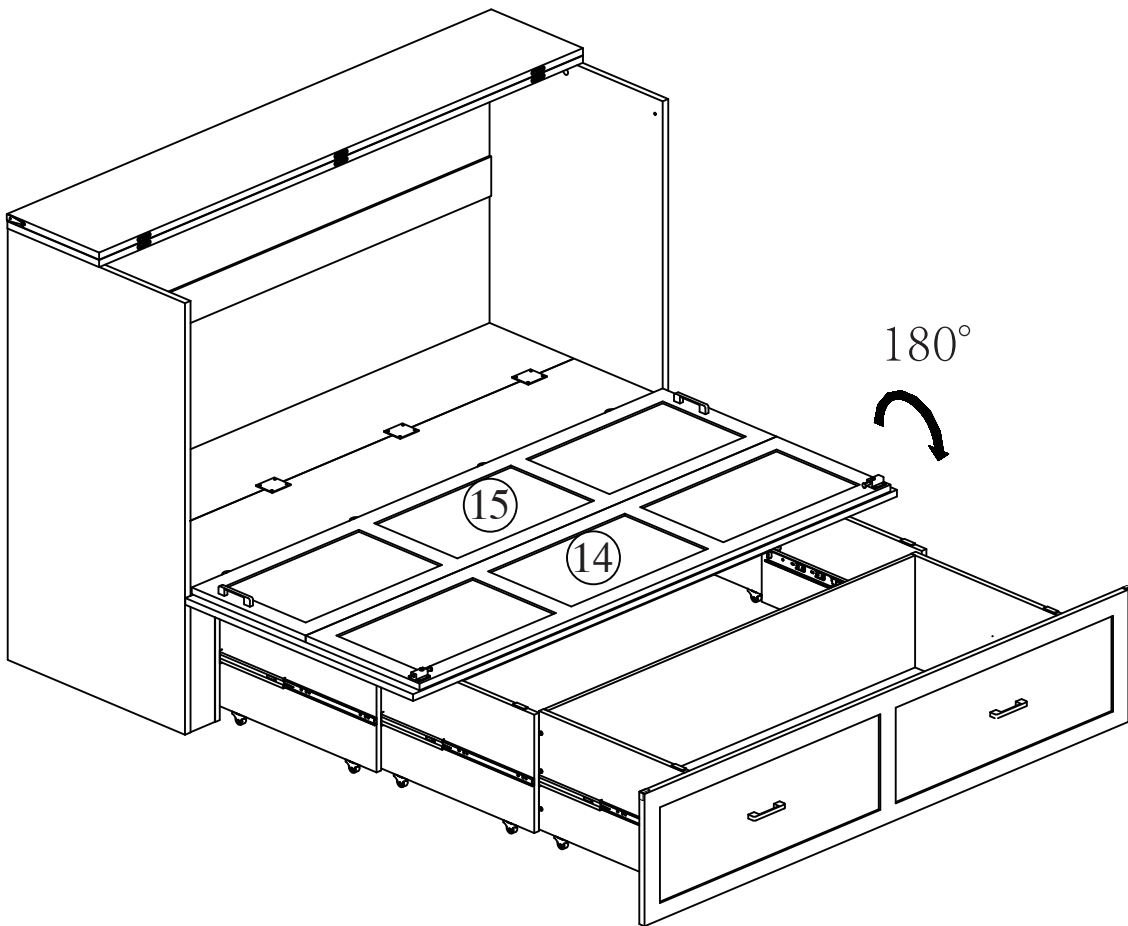
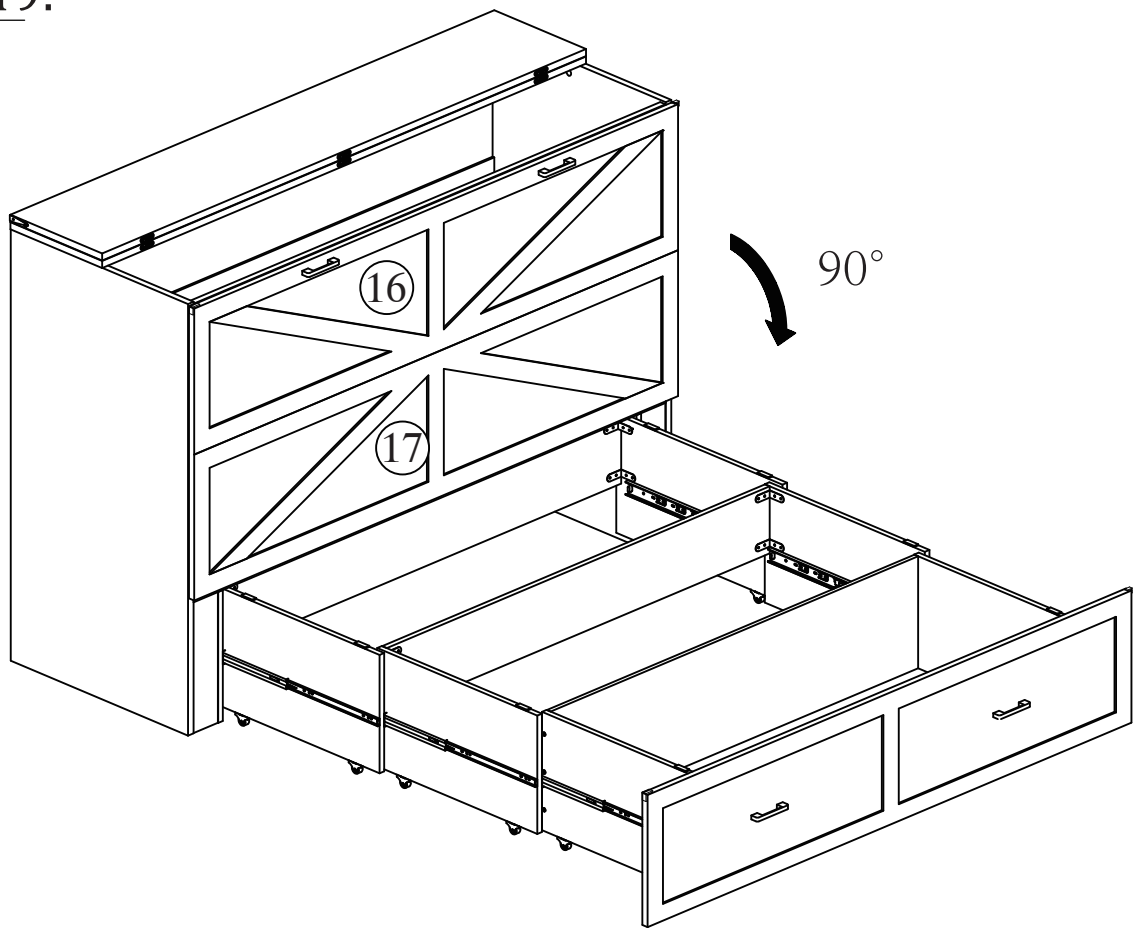

STEP 50:

Étape

