

ASSEMBLY INSTRUCTIONS



DINING CHAIR

ASSEMBLY INSTRUCTIONS

ASSEMBLY TIPS:

1. Remove hardware from box and sort by size.
2. Please check to see that all hardware and parts are present prior to start of assembly.
3. Please follow attached instructions in the same sequence as numbered to assure fast & easy assembly.



WARNING!

1. Don't attempt to repair or modify parts that are broken or defective. Please contact the store immediately.
2. This product is for home use only and not intended for commercial establishments.





ASSEMBLY TIME

10 MINUTES

PARTS IDENTIFICATION

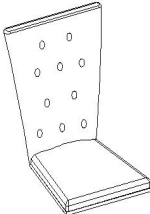
B1 (BOX 1)

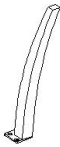
A	SEAT AND BACK		1PCS	D	FRONT LEG		2PCS
B	BACK LEFT LEG	 L	1PC				
C	BACK RIGHT LEG	 R	1PC				

NOTE:

Quantities shown are for on chair

Phillips head screw driver is required in the assembly process; however, manufacturer does not provide this item.

ASSEMBLY INSTRUCTIONS

ASSEMBLY TIPS:

1. Remove hardware from box and sort by size.
2. Please check to see that all hardware and parts are present prior to start of assembly.
3. Please follow attached instructions in the same sequence as numbered to assure fast & easy assembly.



WARNING!

1. Don't attempt to repair or modify parts that are broken or defective. Please contact the store immediately.
2. This product is for home use only and not intended for commercial establishments.

HARDWARE IDENTIFICATION

Z-B2 (BOX 1) - HARDWARE PACK IS LOCATED

1 ALLEN WRENCH		1PC
2 SHORT BOLT (M8*20mm)		12PC

NOTE:

Quantities shown are for on chair

Phillips head screw driver is required in the assembly process; however, manufacturer does not provide this item.

ASSEMBLY INSTRUCTIONS

STEP 1

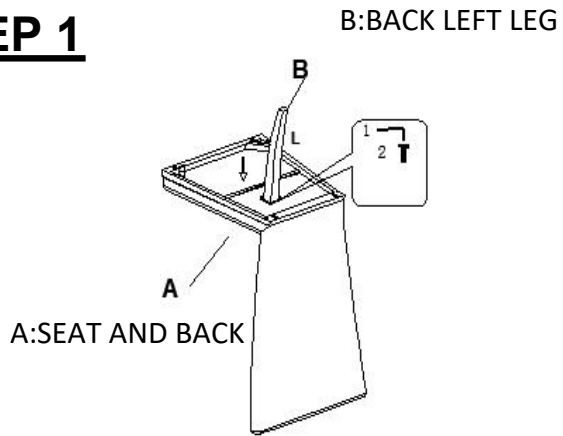

STEP 2

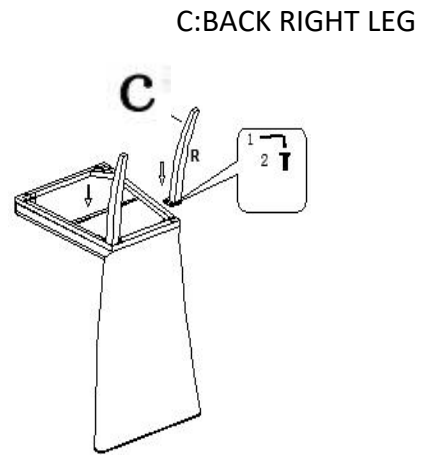

STEP 3

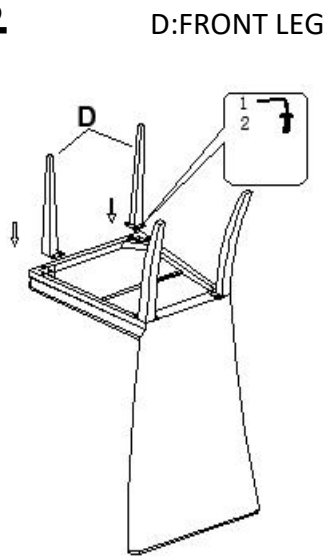

STEP 4

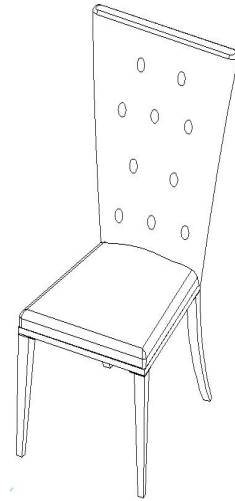

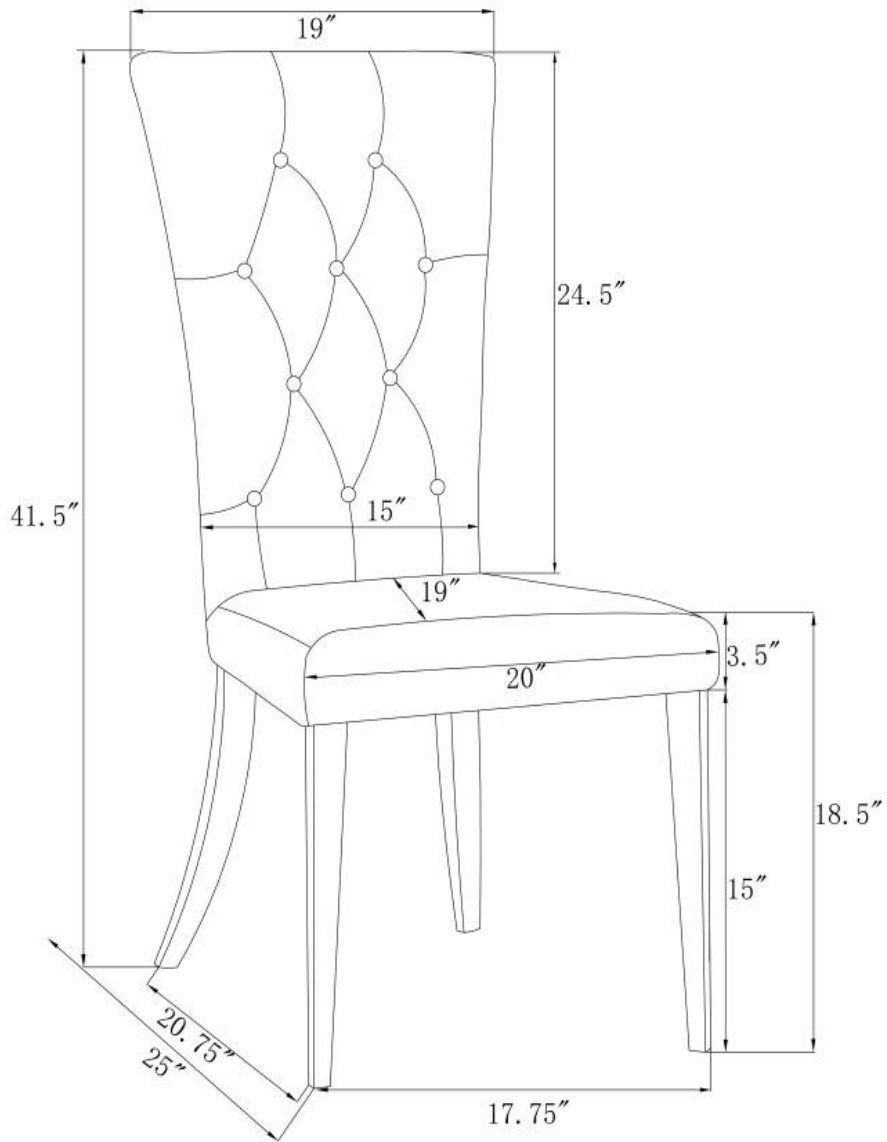

Note : Dimension tolerance $\pm 5\%$